

SPLIT TYPE
ROOM AIR CONDITIONER
WALL MOUNTED TYPE

SERVICE MANUAL

Indoor unit Outdoor unit
ASYG14LMCA AOYG14LMCA



CONTENTS

SPECIFICATIONS.....	1
DIMENSIONS.....	2
REFRIGERANT SYSTEM DIAGRAM.....	3
CIRCUIT DIAGRAM.....	4
INDOOR PCB CIRCUIT DIAGRAM.....	5
OUTDOOR PCB CIRCUIT DIAGRAM.....	9
ERROR DETECTION.....	11
PARTS (INDOOR UNIT).....	13
PARTS (OUTDOOR UNIT).....	17
ACCESSORIES.....	20

SPECIFICATIONS

ELECTRICAL DATA

TYPE		Cool & heat inverter
INDOOR UNIT		ASYG14LMCA
OUTDOOR UNIT		AOYG14LMCA
COOLING CAPACITY		4.00 kW
HEATING CAPACITY		5.00 kW
POWER SOURCE		230 V
FREQUENCY		50 Hz
RUNNING CURRENT	Cooling	5.3 A
	Heating	6.3 A
INPUT WATTS	Cooling	1.14 kW
	Heating	1.37 kW
E.E.R.	Cooling	3.52 kW/kW
COP	Heating	3.66 kW/kW
MOISTURE REMOVAL		2.1 L/h
AIR CIRCULATION HIGH		770 m ³ /h
MAXIMUM CURRENT	Cooling	9.0 A
	Heating	10.5 A

FAN MOTOR

POWER SOURCE		230 V
INDOOR UNIT Cooling	High	1,360 r.p.m.
	Medium	1,220 r.p.m.
	Low	990 r.p.m.
	Quiet	750 r.p.m.
INDOOR UNIT Heating	High	1,360 r.p.m.
	Medium	1,220 r.p.m.
	Low	1,040 r.p.m.
	Quiet	770 r.p.m.
OUTDOOR UNIT Cooling		850 r.p.m.
OUTDOOR UNIT Heating		750 r.p.m.

NOISE LEVEL

INDOOR UNIT Cooling	High	44 dB
	Medium	40 dB
	Low	33 dB
	Quiet	25 dB
OUTDOOR UNIT Heating	High	44 dB
	Medium	40 dB
	Low	35 dB
	Quiet	27 dB
OUTDOOR UNIT Cooling		50 dB
OUTDOOR UNIT Heating		50 dB

COMPRESSOR AND REFRIGERANT

COMPRESSOR TYPE	Hermetic type, 4 pole, 3 phase, DC inverter motor, Rotary	
DISCRIMINATION	DA89X1C-20FZ2	
WEIGHT (with oil)	9.2 kg	
PRECHARGED REFRIGERANT	1,050 g	
REFRIGERANT TYPE	R410A	
FULL CHARGE	Pipe length 15 m	1,050 g
	20 m	1,150 g
ADDITIONAL CHARGE	20 g/m	
MAXIMUM PIPING HEIGHT	15m	

DIMENSIONS

INDOOR UNIT	H x W x D	268 x 840 x 203 mm
OUTDOOR UNIT	H x W x D	540 x 790 x 290 mm

WEIGHT

INDOOR UNIT	Shipping / Net	10.5 kg / 8.5 kg
OUTDOOR UNIT	Shipping / Net	37 kg / 34 kg

DIMENSIONS

INDOOR UNIT

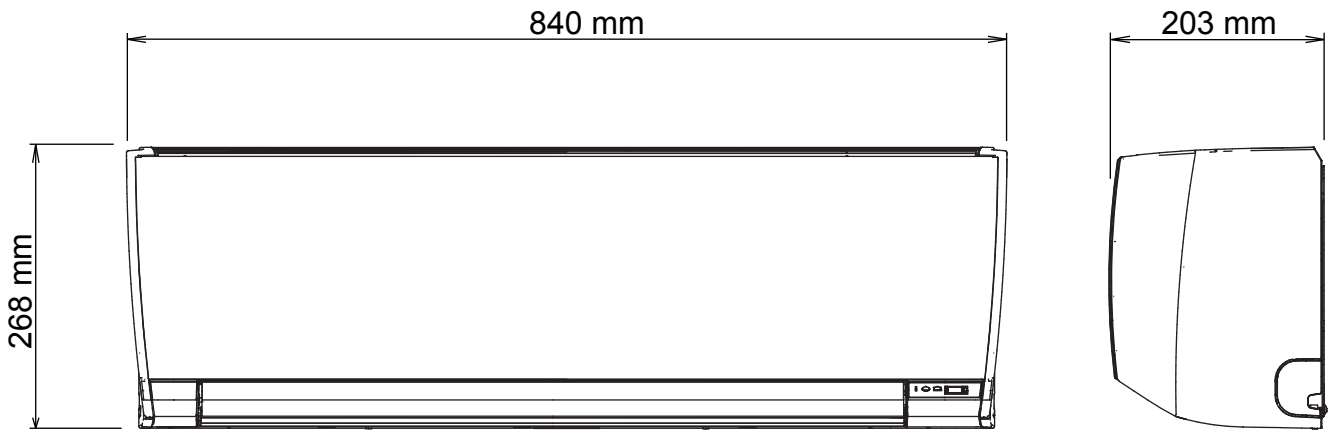

Drain hose

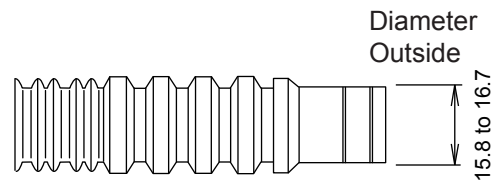
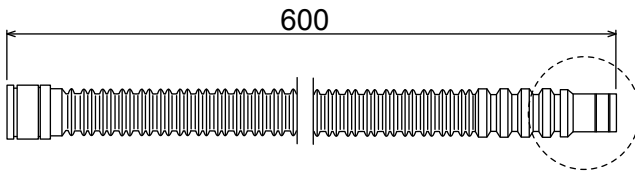

Inside : 13.8 mm

OUTDOOR UNIT

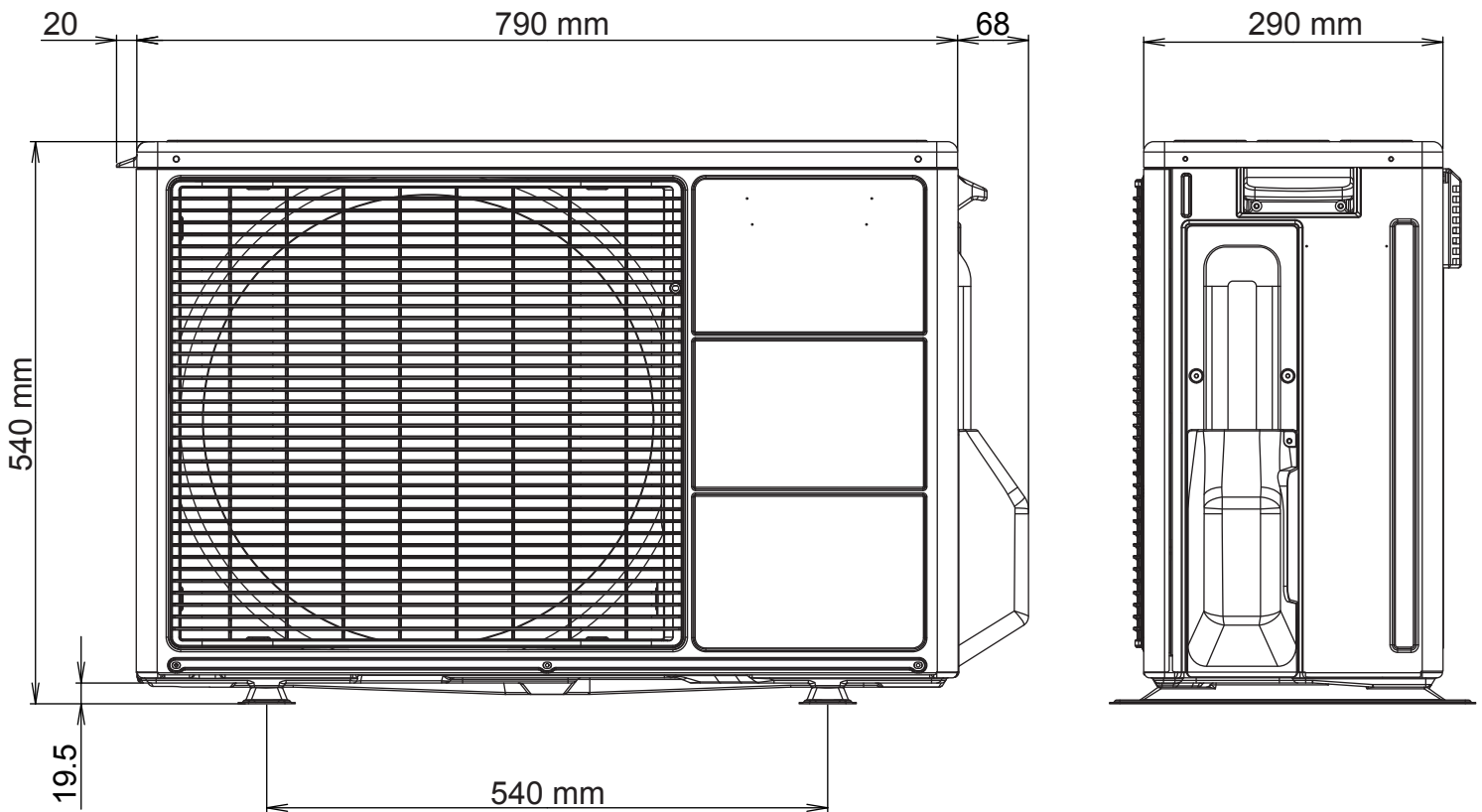

REFRIGERANT SYSTEM DIAGRAM

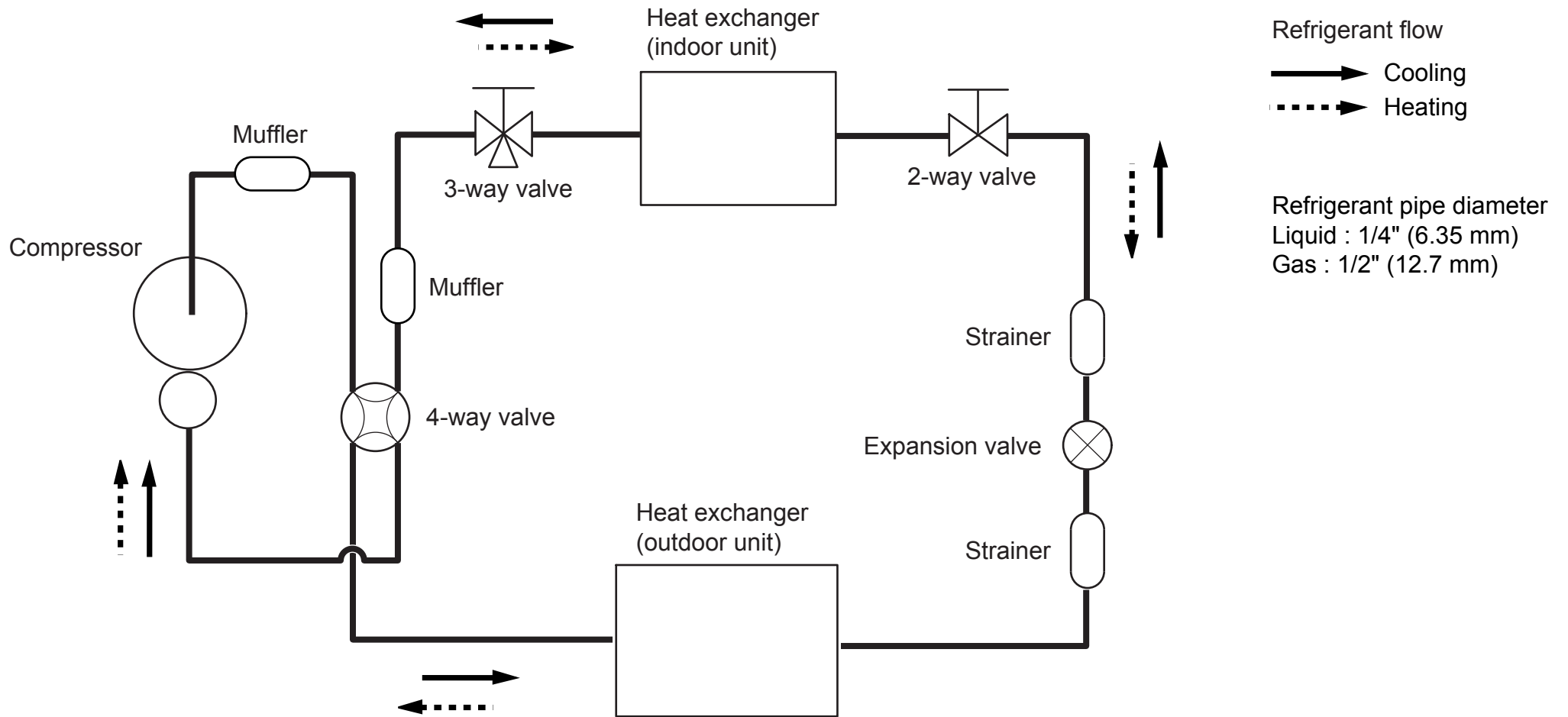

COMMUNICATION PCB
UTY-XCBXZ2 (OPTION)

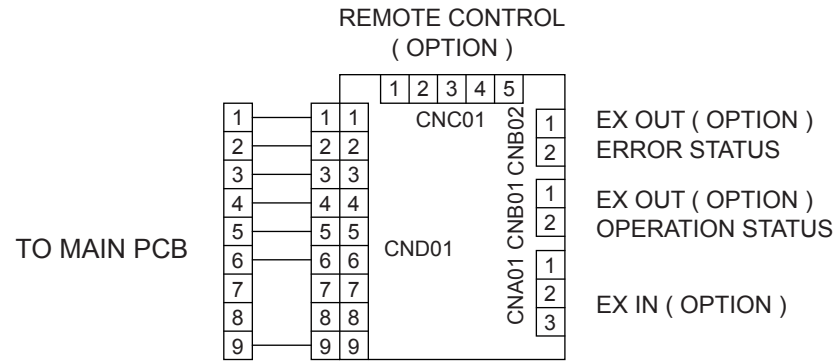

CIRCUIT DIAGRAM

INDOOR UNIT

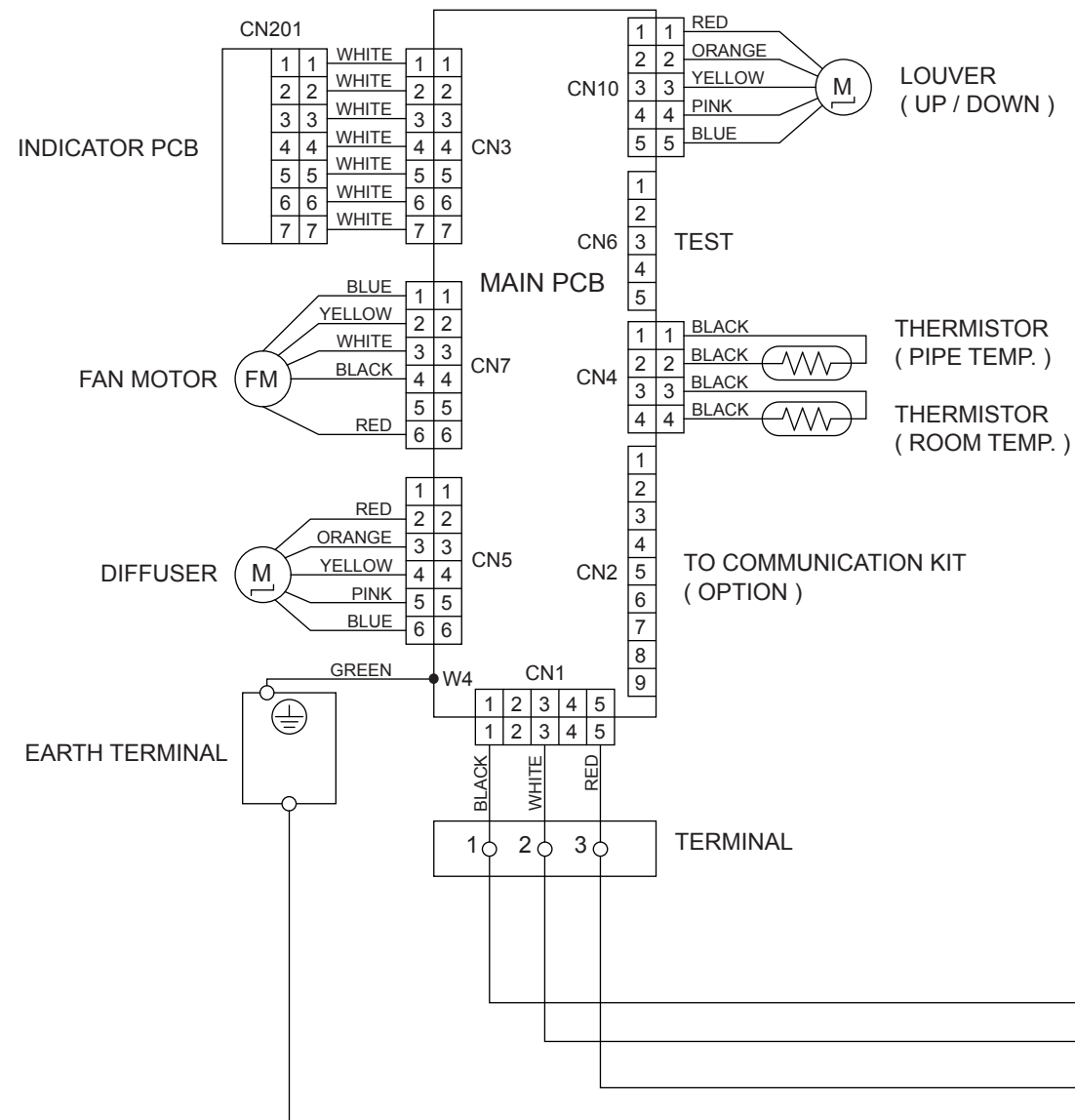

OUTDOOR UNIT

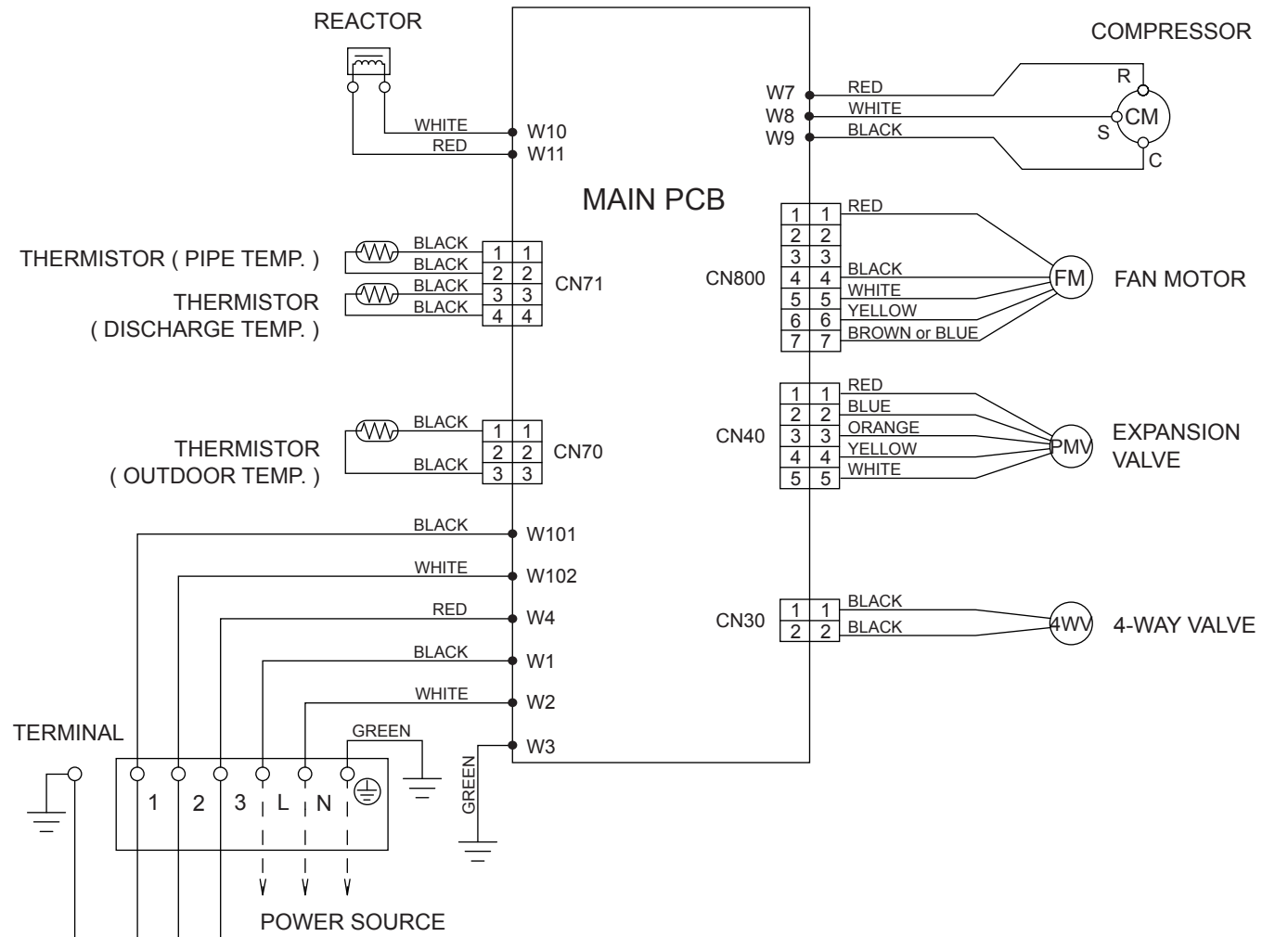

INDOOR UNIT
 MAIN PCB
 K12JY-1203HSE-C1

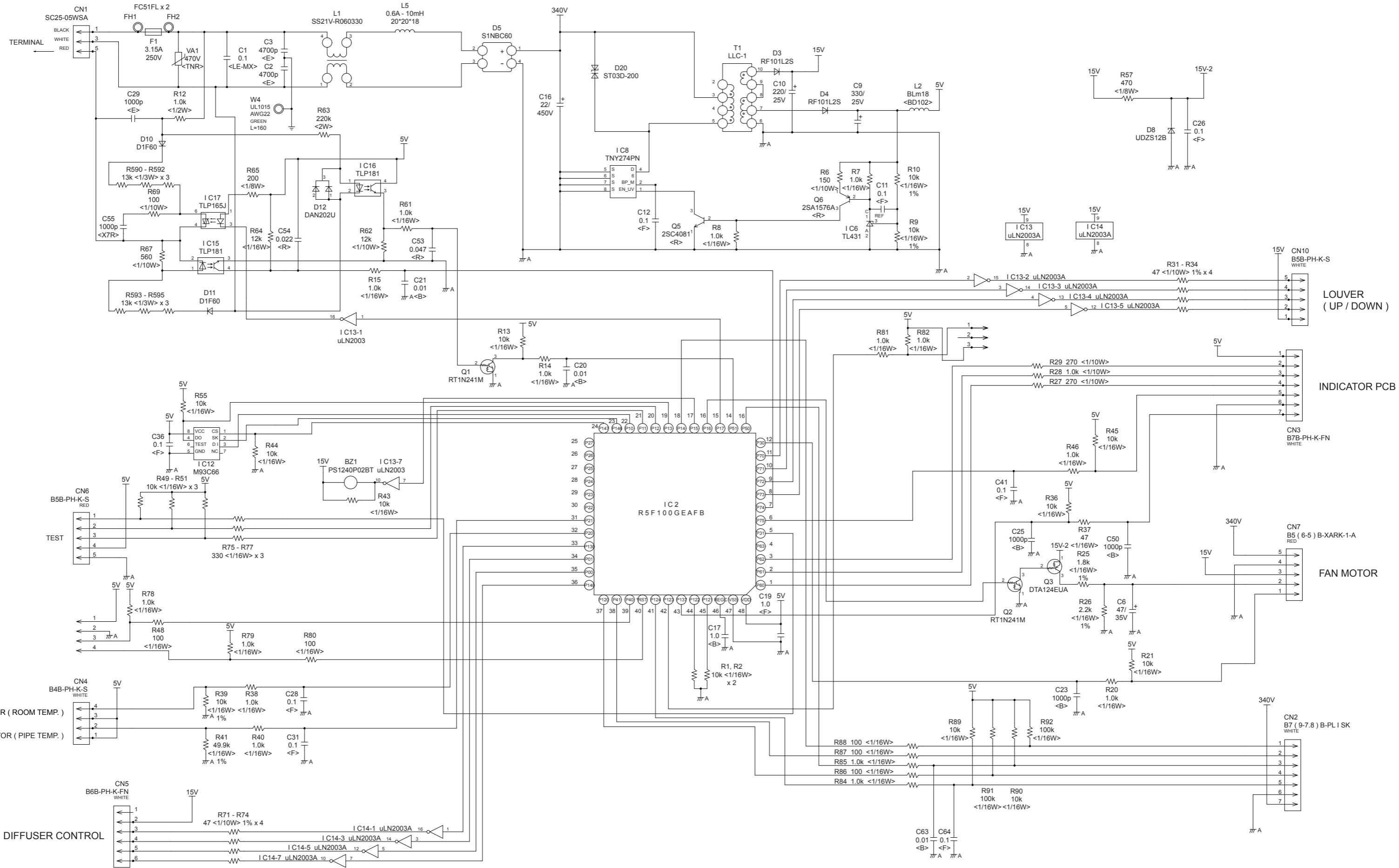

INDOOR UNIT
 INDICATOR PCB
 K12JZ-1200HSE-D0

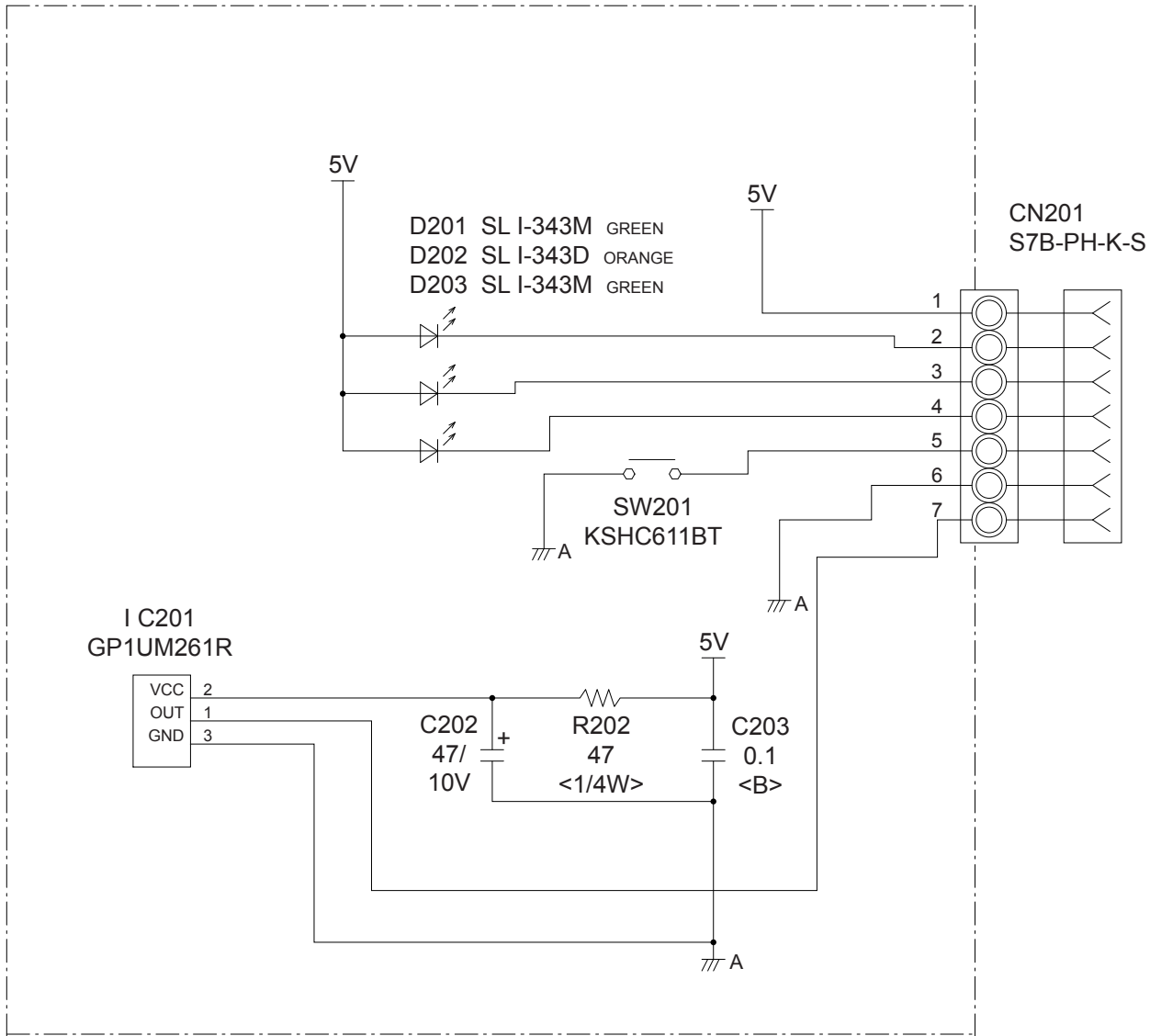

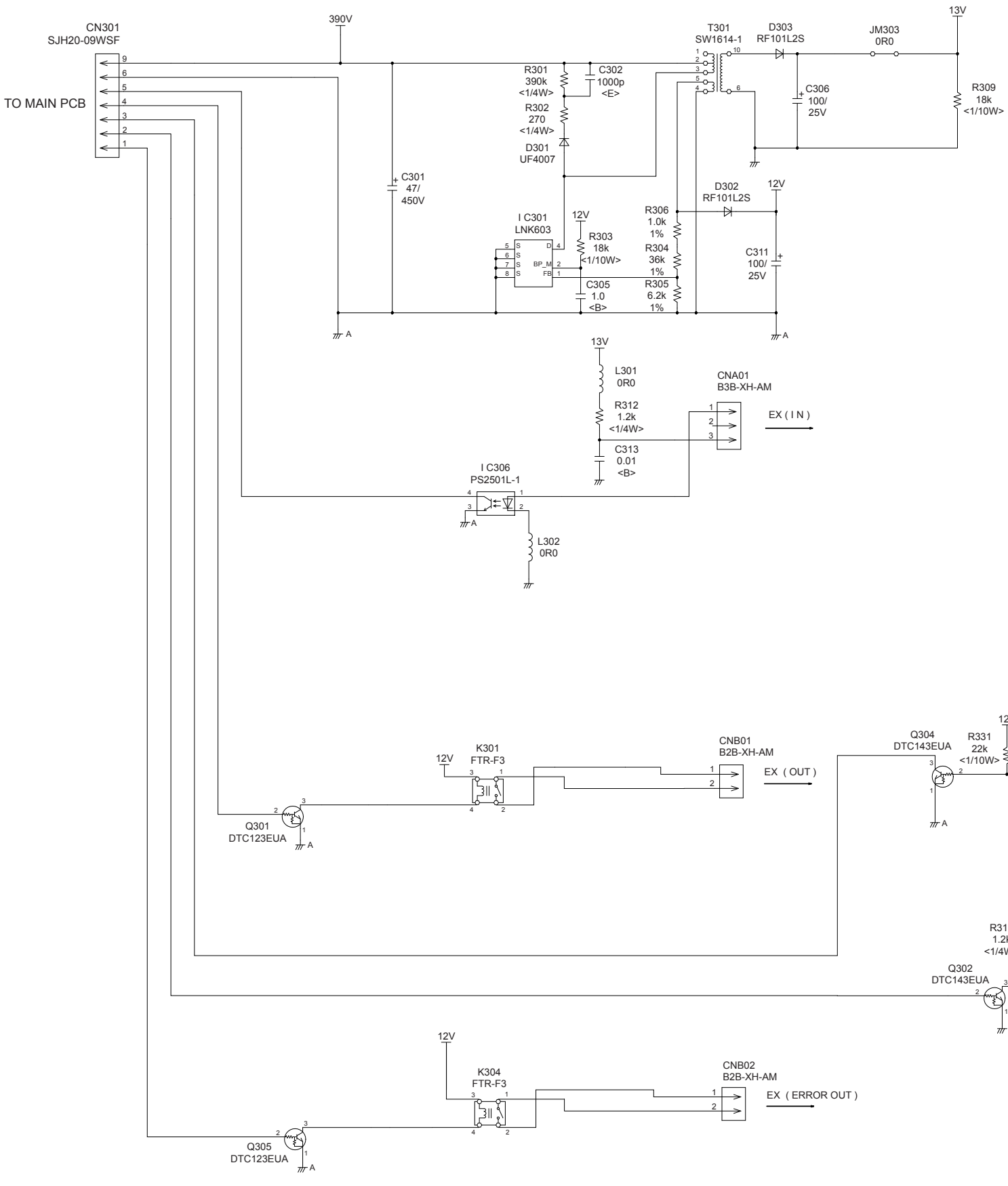

(Option)
 Communication kit
 UTY-XCBXZ2
 Communication PCB
 K10DC-1000HSE-CA0

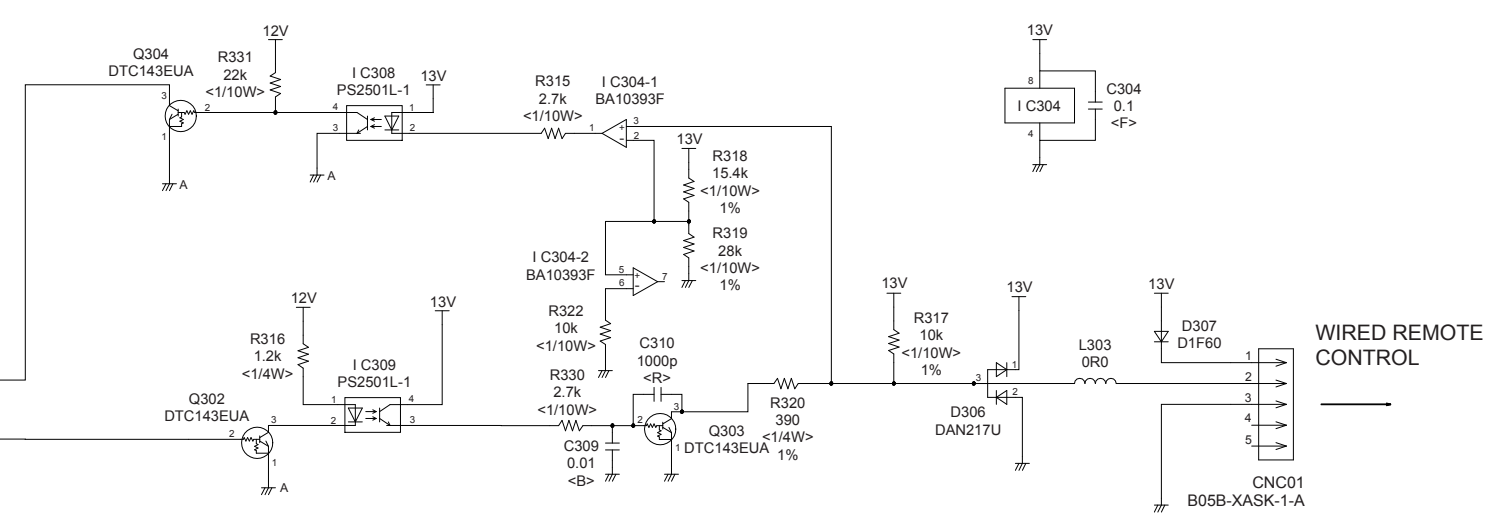

WIRED REMOTE CONTROL

OUTDOOR PCB CIRCUIT DIAGRAM

INVERTER ASSEMBLY
EZ-0122DHUE

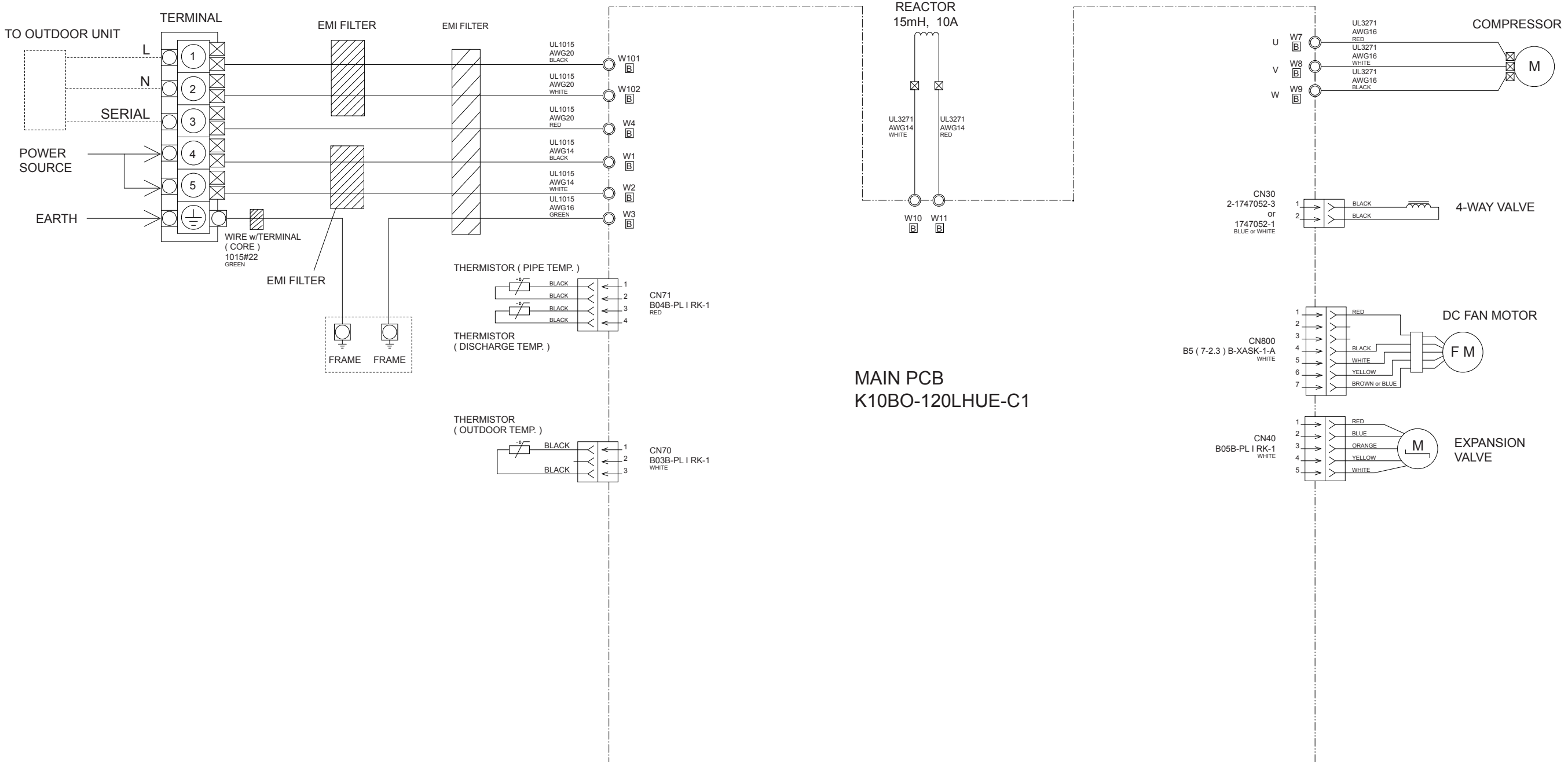

OUTDOOR UNIT
MAIN PCB
K10BO-120LHUE-C1

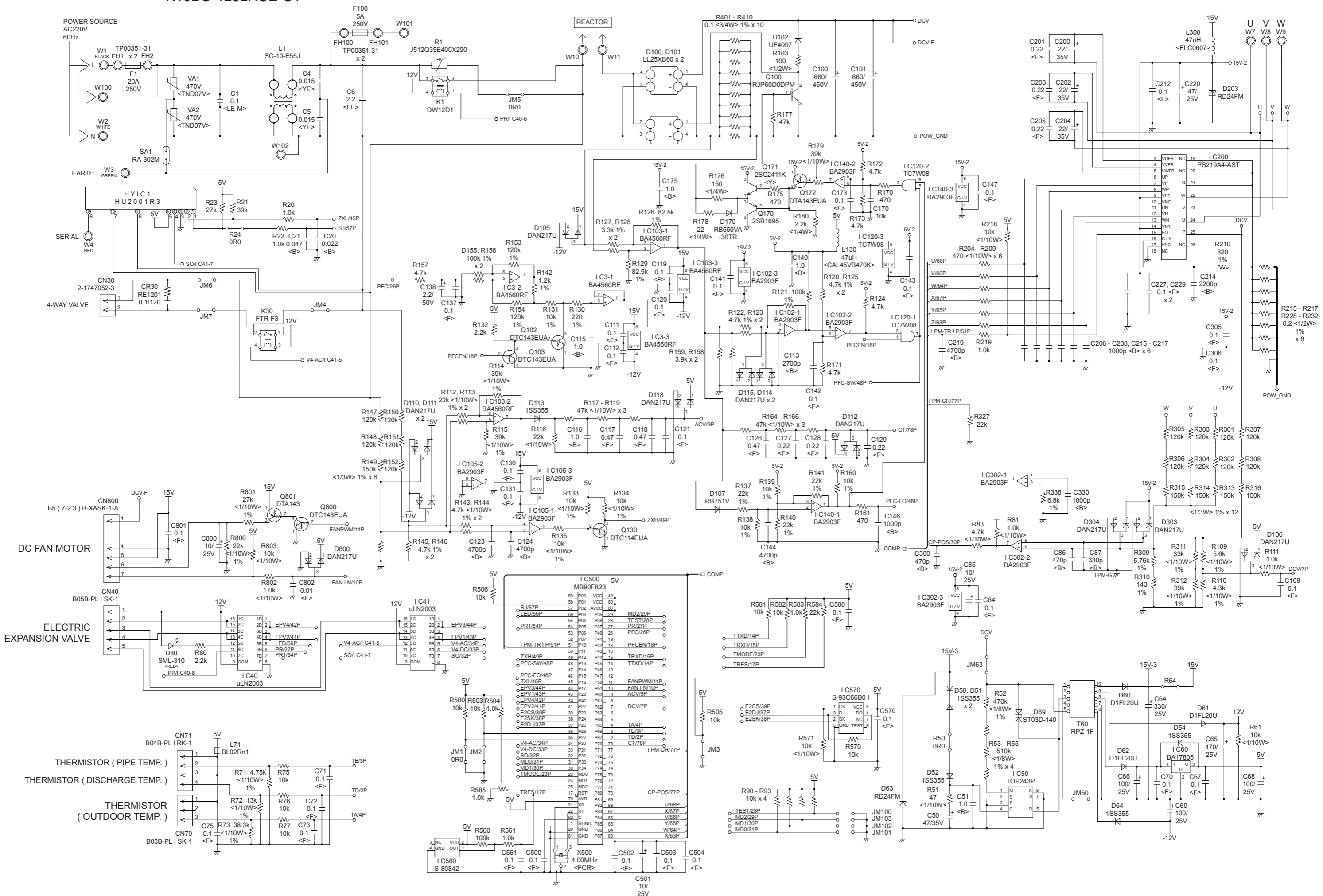

ERROR DETECTION

INDOOR UNIT REMOTE CONTROL

If you use a wireless remote control, the lamp on the photo detector unit will output error codes by way of blinking patterns.

If you use a wired remote control, error codes will appear on the remote control display.

See the lamp blinking patterns and error codes in the table.

An error display is displayed only during operation.

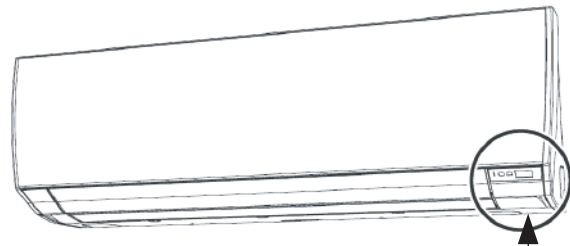

OPERATION indicator lamp (green)
TIMER indicator lamp (orange)
ECONOMY indicator lamp (green)

Wired remote control display (Option)

If an error occurs, the following display will be shown.
("Er" will appear in the set room temperature display.)

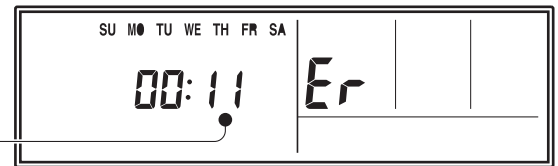

● : 0.5s ON / 0.5s OFF

◇ : 0.1s ON / 0.1s OFF

() : Number of flashing

Indoor unit lamps			Wired remote control	Description
OPERATION (green)	TIMER (orange)	ECONOMY (green)		
● (1)	● (1)	◇	11	Serial communication error
● (1)	● (2)	◇	12	Wired remote control communication error
● (1)	● (5)	◇	15	Check run unfinished
● (2)	● (1)	◇	21	Unit number or Refrigerant circuit address setting error [Simultaneous Multi]
● (2)	● (2)	◇	22	Indoor unit capacity error
● (2)	● (3)	◇	23	Combination error
● (2)	● (4)	◇	24	•Connection unit number error (indoor unit) [Simultaneous Multi] •Connection unit number error (indoor unit or branch unit) [Flexible Multi]
● (2)	● (7)	◇	27	Master unit, slave unit set-up error [Simultaneous Multi]
● (3)	● (2)	◇	32	Indoor unit PCB model information error
● (3)	● (5)	◇	35	Manual auto switch error
● (4)	● (1)	◇	41	Room temp. sensor error
● (4)	● (2)	◇	42	Indoor unit Heat Ex. Middle temp. sensor error
● (5)	● (1)	◇	51	Indoor unit fan motor error
● (5)	● (3)	◇	53	Drain pump error
● (5)	● (7)	◇	57	Damper error
● (5)	● (8)	◇	58	Intake grill error
● (5)	● (15)	◇	5U	Indoor unit error
● (6)	● (2)	◇	62	Outdoor unit main PCB model information error or communication error
● (6)	● (3)	◇	63	Inverter error
● (6)	● (4)	◇	64	Active filter error, PFC circuit error
● (6)	● (5)	◇	65	Trip terminal L error

Indoor unit lamps			Wired remote control	Description
OPERATION (green)	TIMER (orange)	ECONOMY (green)		
● (6)	● (10)	◇	6A	Display PCB microcomputers communication error
● (7)	● (1)	◇	71	Discharge temp. sensor error
● (7)	● (2)	◇	72	Compressor temp. sensor error
● (7)	● (3)	◇	73	Outdoor unit Heat Ex. liquid temp. sensor error
● (7)	● (4)	◇	74	Outdoor temp. sensor error
● (7)	● (5)	◇	75	Suction Gas temp. sensor error
● (7)	● (6)	◇	76	• 2-way valve temp. sensor error • 3-way valve temp. sensor error
● (7)	● (7)	◇	77	Heat sink temp. sensor error
● (8)	● (2)	◇	82	• Sub-cool Heat Ex. gas inlet temp. sensor error • Sub-cool Heat Ex. gas outlet temp. sensor error
● (8)	● (3)	◇	83	Liquid pipe temp. sensor error
● (8)	● (4)	◇	84	Current sensor error
● (8)	● (6)	◇	86	• Discharge pressure sensor error • Suction pressure sensor error • High pressure switch error
● (9)	● (4)	◇	94	Trip detection
● (9)	● (5)	◇	95	Compressor rotor position detection error (permanent stop)
● (9)	● (7)	◇	97	Outdoor unit fan motor error
● (9)	● (9)	◇	99	4-way valve error
● (10)	● (1)	◇	A1	Discharge temp. error
● (10)	● (3)	◇	A3	Compressor temp. error
● (10)	● (4)	◇	A4	High pressure error
● (10)	● (5)	◇	A5	Low pressure error
● (13)	● (2)	◇	J2	Branch boxes error

OUTDOOR UNIT

Indicator lamp	Error
on	Discharge temperature error
0.5 second on / 0.5 second off	IPM overcurrent protection
0.1 second on / 0.1 second off	Thermistor error
2.0 second on / 2.0 second off	CT error
0.1 second on / 2.0 second off	Compressor location error
5.0 second on / 5.0 second off	Fan error

PARTS

INDOOR UNIT
ASYG14LMCA

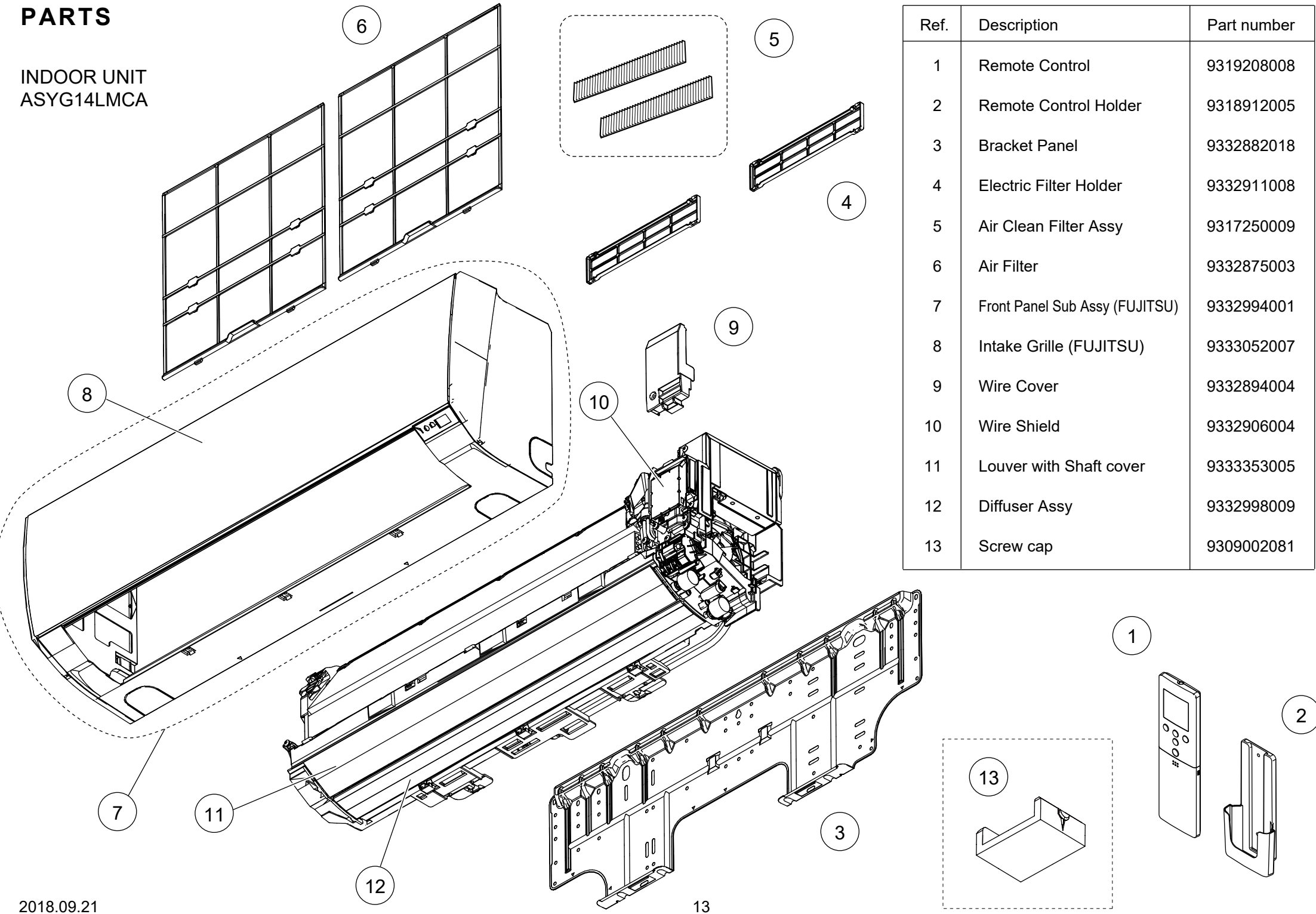

Ref.	Description	Part number
1	Remote Control	9319208008
2	Remote Control Holder	9318912005
3	Bracket Panel	9332882018
4	Electric Filter Holder	9332911008
5	Air Clean Filter Assy	9317250009
6	Air Filter	9332875003
7	Front Panel Sub Assy (FUJITSU)	9332994001
8	Intake Grille (FUJITSU)	9333052007
9	Wire Cover	9332894004
10	Wire Shield	9332906004
11	Louver with Shaft cover	9333353005
12	Diffuser Assy	9332998009
13	Screw cap	9309002081

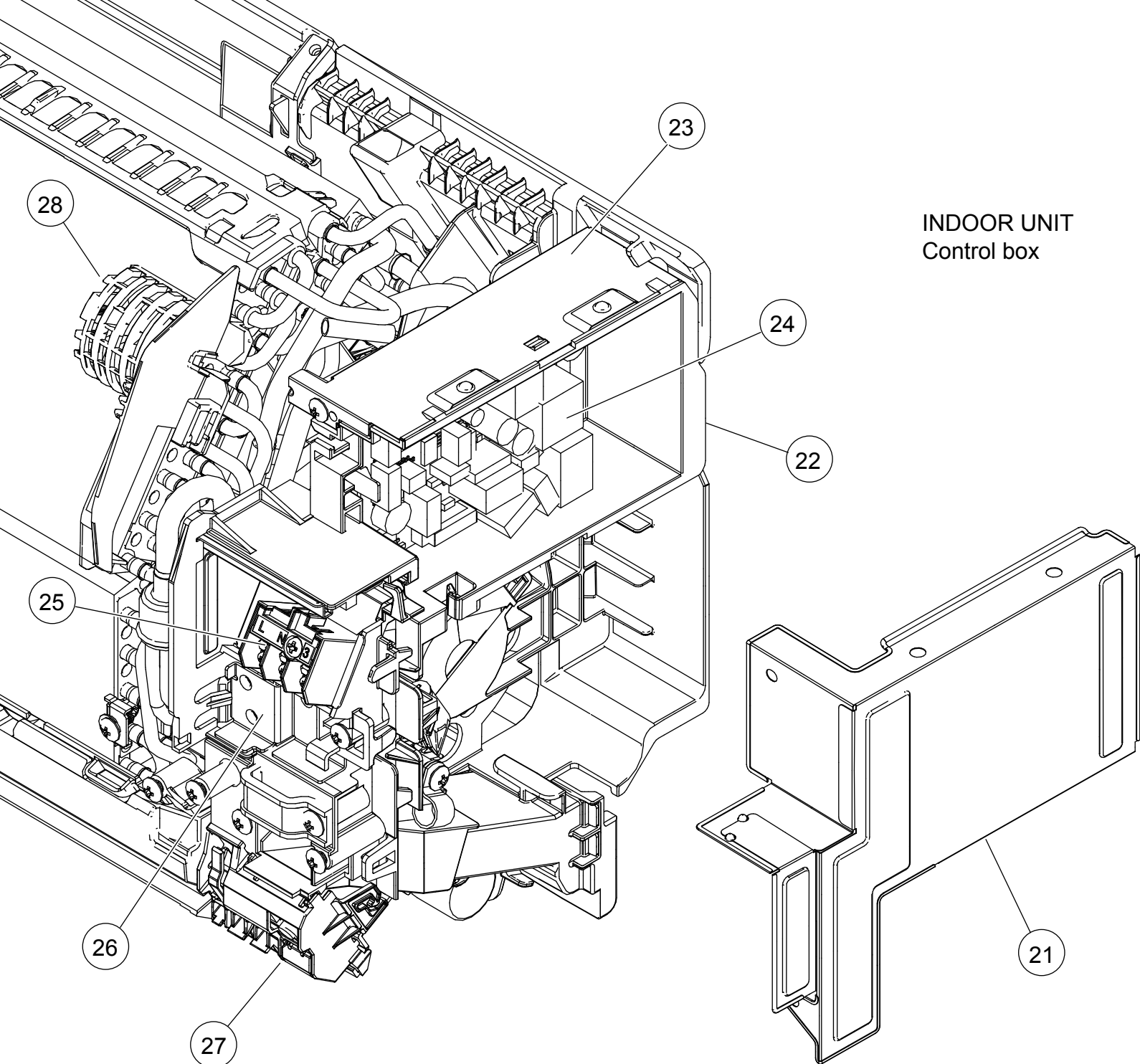

INDOOR UNIT
Control box

Ref.	Description	Part number
21	Cover Shield	9332915006
22	Control Box	9332892000
23	Box Shield Assy	9332877007
24	Main PCB	9709427040
25	Terminal	9900720001
26	Earth Terminal	9332880007
27	Display Assy	9709430019
28	Room Thermistor Holder	9332868005
--	Thermistor Assy	9900714024

INDOOR UNIT
Evaporator
Fan

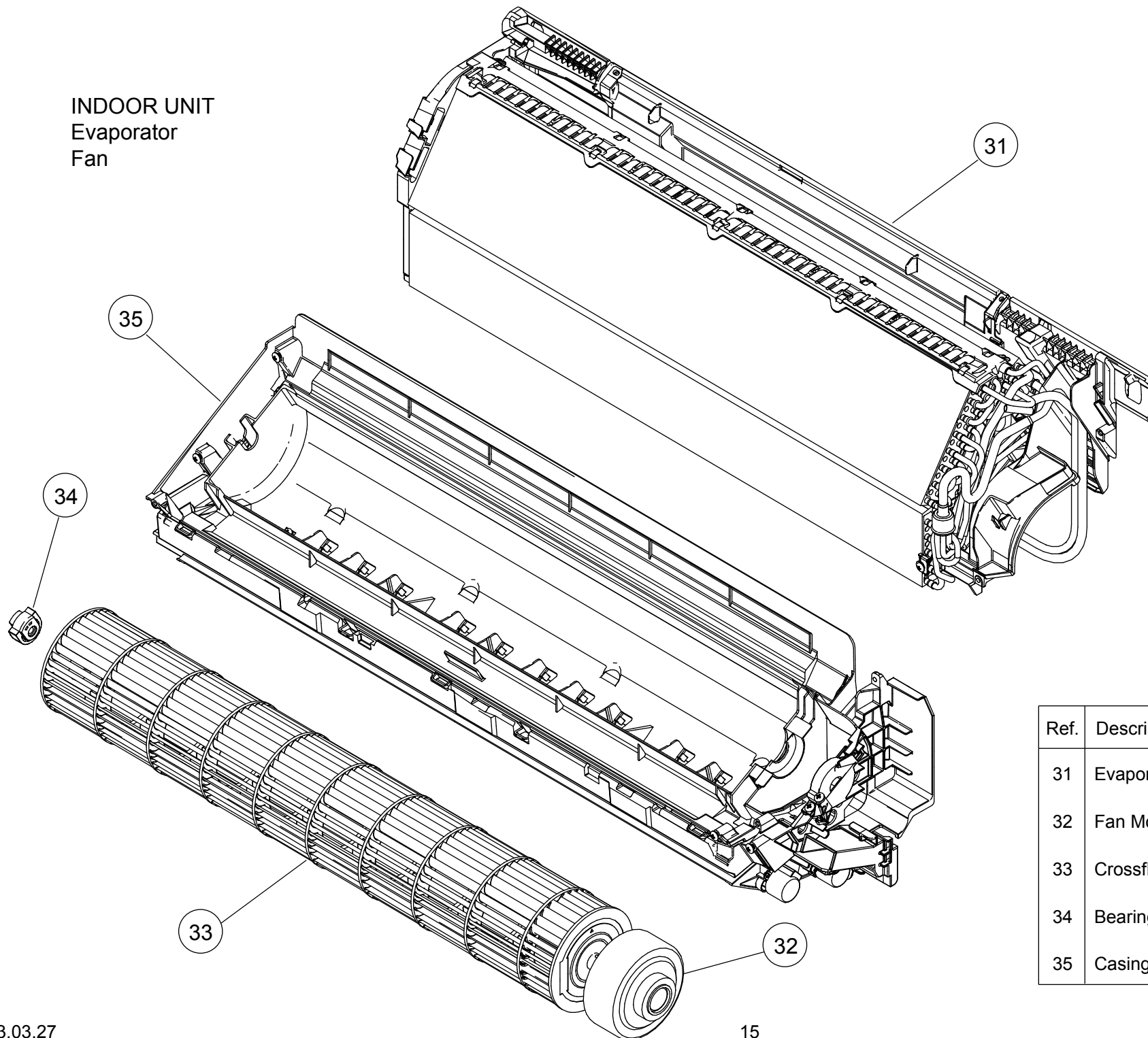

Ref.	Description	Part number
31	Evaporator Total Assy	9332989014
32	Fan Motor	9603269005
33	Crossflow Fan Assy	9316830004
34	Bearing C Assy	9306628017
35	Casing Assy	9333009001

INDOOR UNIT
Casing assy

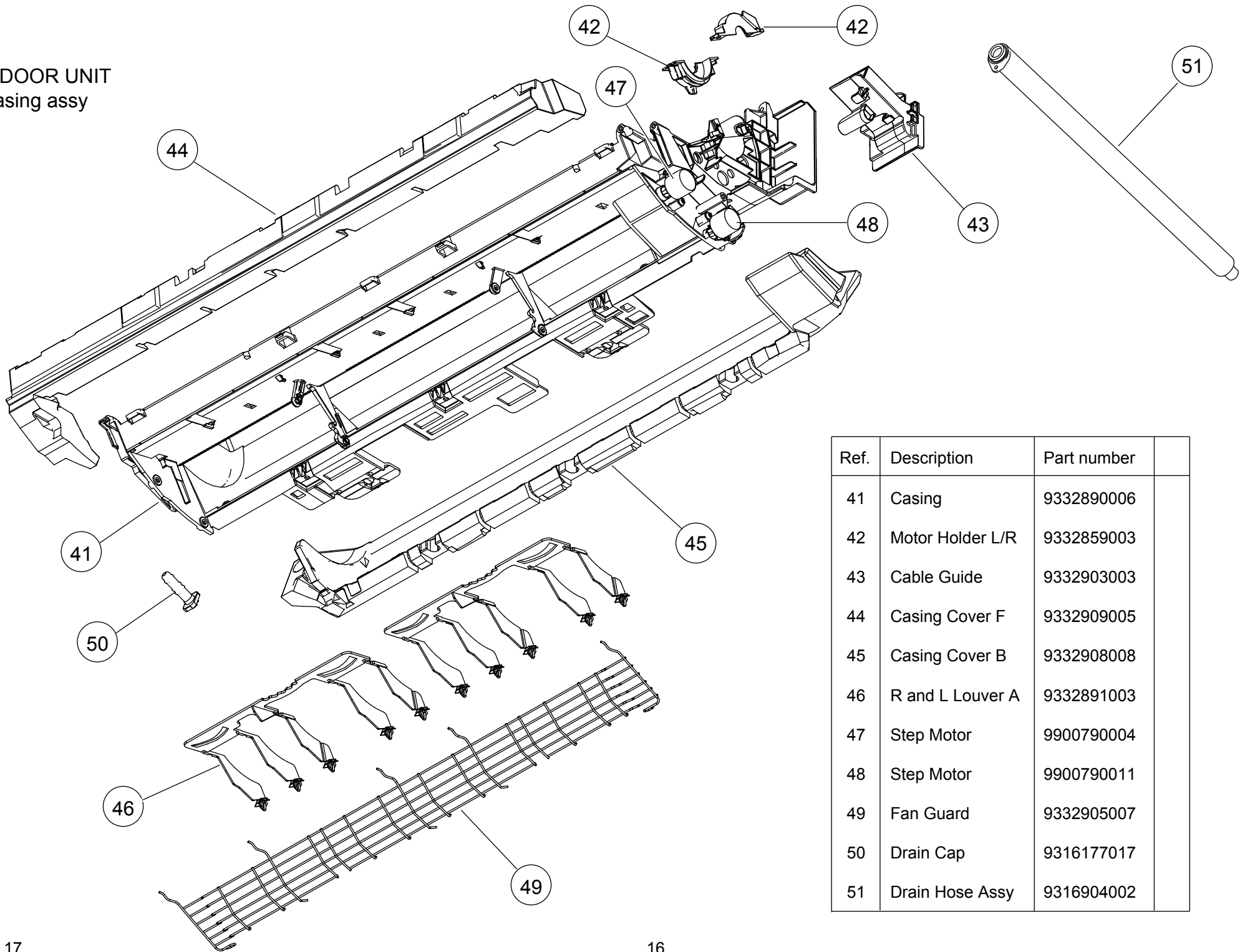

Ref.	Description	Part number
41	Casing	9332890006
42	Motor Holder L/R	9332859003
43	Cable Guide	9332903003
44	Casing Cover F	9332909005
45	Casing Cover B	9332908008
46	R and L Louver A	9332891003
47	Step Motor	9900790004
48	Step Motor	9900790011
49	Fan Guard	9332905007
50	Drain Cap	9316177017
51	Drain Hose Assy	9316904002

PARTS

OUTDOOR UNIT

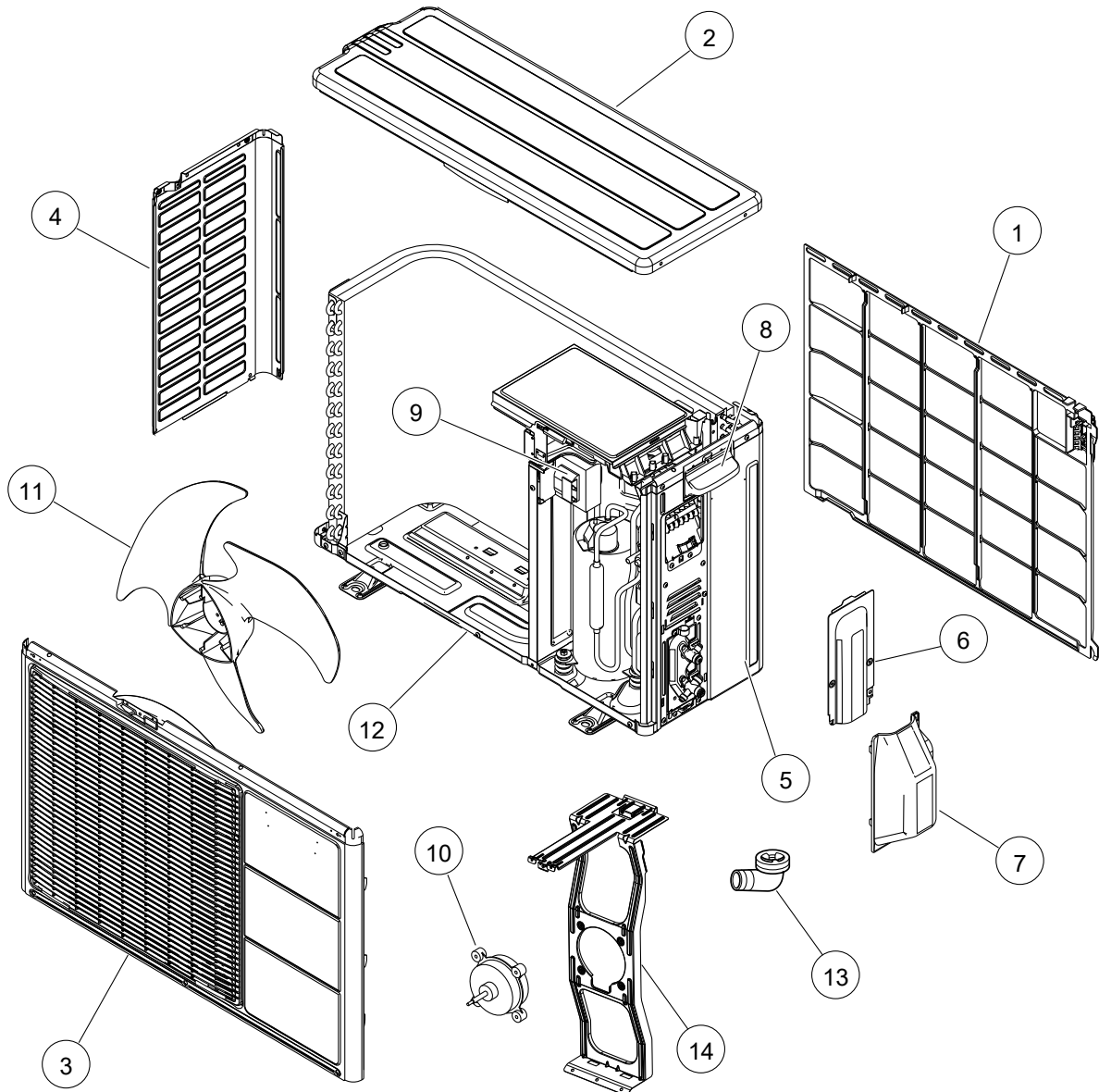

Ref.	Description	Part number
1	Protective Net	9313941055
2	Top Panel Assy	9317761055
3	Front Panel Assy	9317760041
4	Cabinet Left	9318247008
5	Cabinet Right Assy	9317759021
6	Switch Cover A Assy	9317795005
7	Switch Cover B	9317582001
8	Grip	9317588003

Ref.	Description	Part number
9	Reactor Assy	9900788018
10	Fan Motor	9602864003
11	Propeller Fan	9313808013
12	Base Assy	9316885028
13	Drain Assy	9303029022
14	Motor Bracket Assy	9332289039
--	Emblem	9319151007

OUTDOOR UNIT

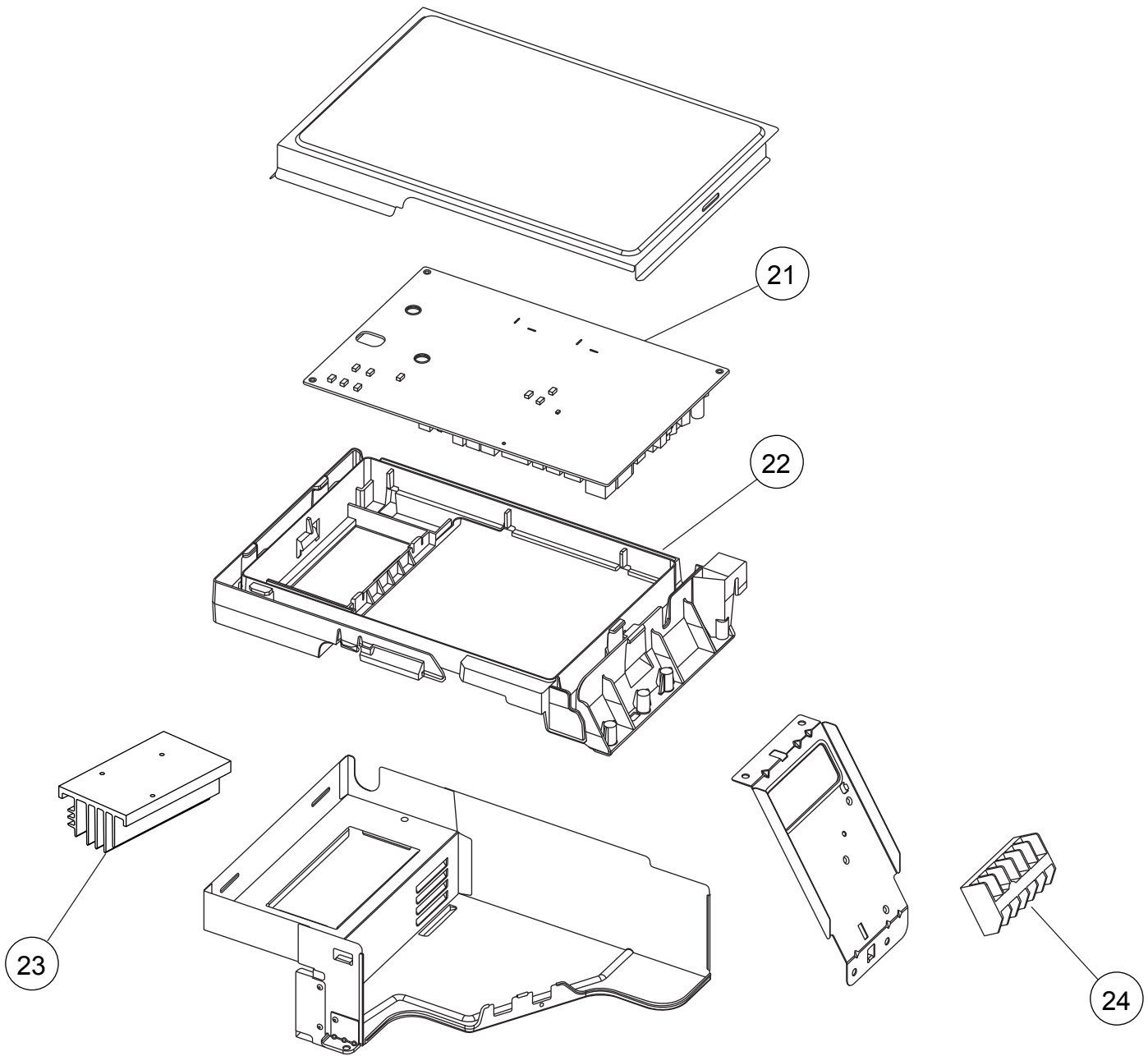

Ref.	Description	Part number	
21	Main PCB	9708683478	
22	PCB Holder	9318182002	
23	Heat Sink	9319070001	
24	Terminal	9900435028	
--	Outdoor Thermistor	9900565008	
--	Thermistor Assy	9900628000	

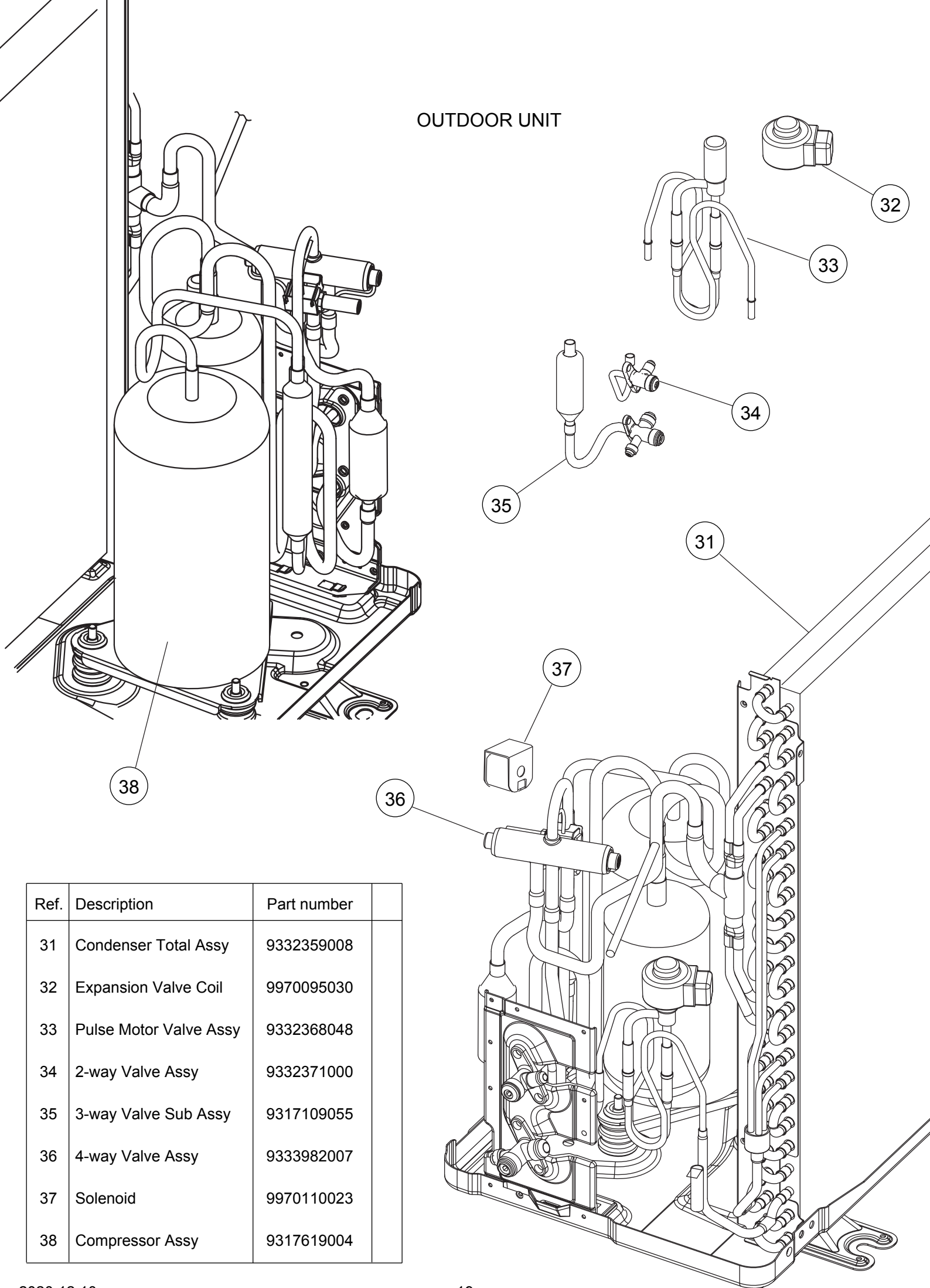

OUTDOOR UNIT





Ref.	Description	Part number
31	Condenser Total Assy	9332359008
32	Expansion Valve Coil	9970095030
33	Pulse Motor Valve Assy	9332368048
34	2-way Valve Assy	9332371000
35	3-way Valve Sub Assy	9317109055
36	4-way Valve Assy	9333982007
37	Solenoid	9970110023
38	Compressor Assy	9317619004

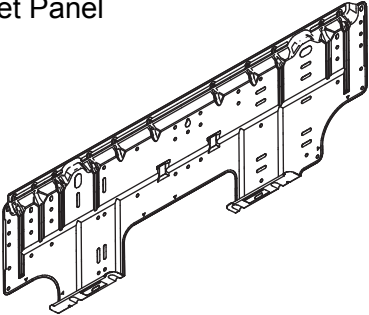
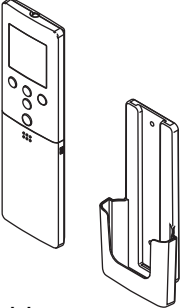
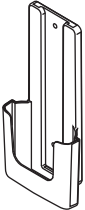

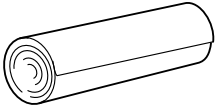
ACCESSORIES

INDOOR UNIT

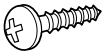
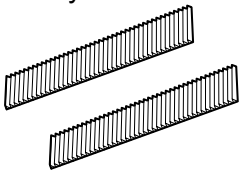
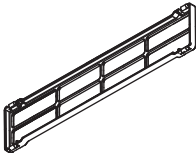
Name and Shape	Part number
Bracket Panel 	9332882018
Remote Control 	9319208008
Remote Control Holder 	9318912005
Battery (penlight) 	0600185541
Cloth tape 	9310519004

Name and Shape	Part number
Seal A 	9304536000
Tapping screw (M4 x 25 mm) 	0700076046
Tapping screw (M3 x 12 mm) 	0700019036
Air cleaning filter assy 	9317250009
Filter holder 	9332911008

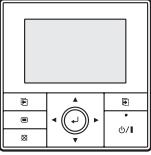
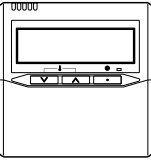
OPTIONAL PARTS

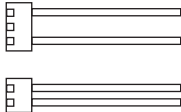
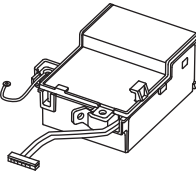
Name and Shape	Part number
Wired remote control UTY-RVNYM 	
Wired remote control UTY-RNNYM 	
Simple remote Control UTY-RSNYM 	
External connect kit UTY-XWZXZ5 	
Communication kit UTY-XCBXZ2 	

OUTDOOR UNIT

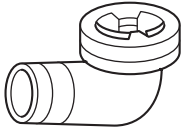
Name and Shape	Part number
Drain assy 	9303029022

1303G4202