

SERVICE MANUAL



Indoor unit	Outdoor unit
ASYA07LACM	AOY18LMAK2
ASYA09LACM	
ASYA12LACM	
ASYA14LACM	
ASYA07LACM	AOY24LMAM2
ASYA09LACM	
ASYA12LACM	
ASYA14LACM	
ASYA18LACM	

CONTENTS

SPECIFICATIONS	1
OUTLINE AND DIMENSIONS	3
REFRIGERANT SYSTEM DIAGRAM ...	5
CIRCUIT DIAGRAM	6
PCB CIRCUIT DIAGRAM	8
ERROR CONTENTS	12
PARTS (indoor unit)	14
PARTS (outdoor unit)	17
ACCESSORIES	21

SPECIFICATIONS

INDOOR UNIT

ELECTRICAL DATA

TYPE	COOL & HEAT				
INDOOR UNIT	ASYA07LACM	ASYA09LACM	ASYA12LACM	ASYA14LACM	ASYA18LACM
COOLING CAPACITY	2.3 kW	2.7 kW	3.5 kW	4.2 kW	5.0 kW
HEATING CAPACITY	2.7 kW	3.3 kW	4.0 kW	4.8 kW	6.0 kW
MOISTURE REMOVAL	0.8 L/hr	1.0 L/hr	1.2 L/hr	1.4 L/hr	2.0 L/hr
AIR CIRCULATION HIGH	500 m3/hr	550 m3/hr	580 m3/hr	700 m3/hr	700 m3/hr

FAN MOTOR

POWER SOURCE	230 V					
FAN SPEED (cool / heat)	Discrimination	MFD-34ROM				
	High	1,140 / 1,140 r.p.m.	1,220 / 1,220 r.p.m.	1,280 / 1,320 r.p.m.	1,480 / 1,480 r.p.m.	1,480 / 1,480 r.p.m.
	Middle	1,000 / 1,050 r.p.m.	1,060 / 1,110 r.p.m.	1,100 / 1,180 r.p.m.	1,250 / 1,250 r.p.m.	1,250 / 1,250 r.p.m.
	Low	880 / 980 r.p.m.	900 / 1,040 r.p.m.	900 / 1,080 r.p.m.	1,050 / 1,100 r.p.m.	1,100 / 1,100 r.p.m.
	Quiet	700 / 800 r.p.m.	720 / 830 r.p.m.	750 / 860 r.p.m.	850 / 950 r.p.m.	950 / 950 r.p.m.

NOISE LEVEL

HIGH	35 dB(A)	38 dB(A)	39 dB(A)	45 dB(A)	45 dB(A)
QUIET	21 dB(A)	22 dB(A)	23 dB(A)	26 dB(A)	28 dB(A)

MEASUREMENT

DIMENSIONS H x W x D	275 x 790 x 215 mm				
WEIGHT Gross / Net	12 kg / 9 kg				

OUTDOOR UNIT

ELECTRICAL SPECIFICATIONS

TYPE		Cooling & heating multi	Cooling & heating multi
MODEL NAME		AOY18LMAK2	AOY24LMAM2
COOLING CAPACITY		5.5 kW	5.8 kW
HEATING CAPACITY		6.3 kW	6.4 kW
POWER SUPPLY		230 V	230 V
FREQUENCY		50 Hz	50 Hz
RUNNING CURRENT	Cooling	7.3 A	7.6 A
	Heating	7.3 A	7.2 A
INPUT	Cooling	1.65 kW	1.73 kW
	Heating	1.65 kW	1.64 kW
EER	Cooling	3.33 kW/kW	3.35 kW/kW
	Heating	3.82 kW/kW	3.90 kW/kW
AIR CIRCULATION HIGH		2,800 m ³ /hr	2,800 m ³ /hr
MAX CURRENT		10.5 A	12.5 A

FAN MOTOR

DISCRIMINATION	MFB24JTAT
HIGH SPEED (COOL)	780 r.p.m.
HIGH SPEED (HEAT)	780 r.p.m.

NOISE LEVEL

COOL	49 dB(A)
HEAT	50 dB(A)

MEASUREMENT

DIMENSIONS	H x W x D	650 x 830 x 320 mm
WEIGHT	Net / Gross	56 kg / 62 kg

COMPRESSOR AND REFRIGERANT

COMPRESSOR TYPE	Hermetic type, Inverter, 4 poles, 3-phase, DC motor, Twin Rotary
DISCRIMINATION	TNB220FPCMT
WEIGHT (with oil)	14.1 kg
STANDARD REFRIGERANT	1,900 g
REFRIGERANT TYPE	R410A
ADDITIONAL CHARGE	Chargeless
MAX PIPE LENGTH (each unit)	20 m
MAX PIPE LENGTH (total)	30 m
MIN. PIPE LENGTH (each unit)	5 m
MIN. PIPE LENGTH (total)	10 m
MAX ELEVATION (between indoor units)	10 m
MAX ELEVATION (between indoor and outdoor)	10 m

DIMENSIONS

INDOOR UNIT

(unit : mm)

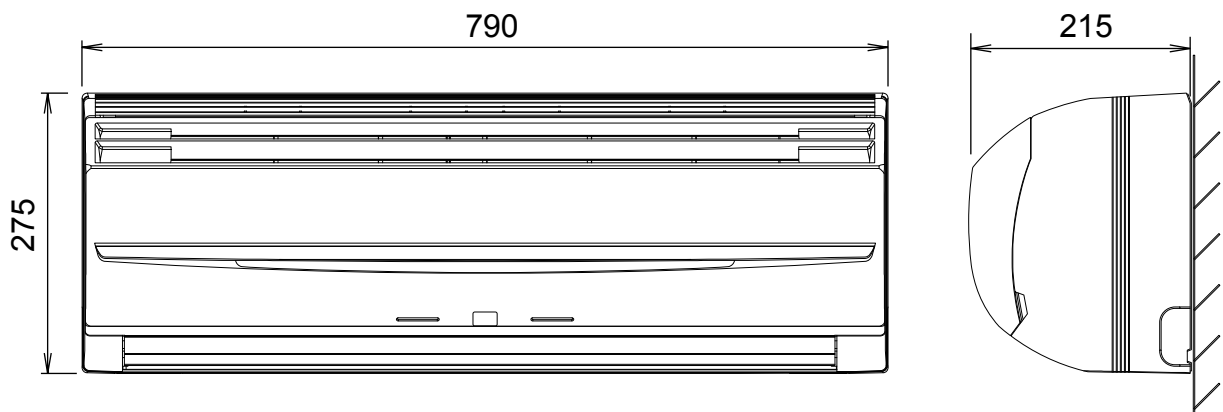

OUTDOOR UNIT

Unit : mm

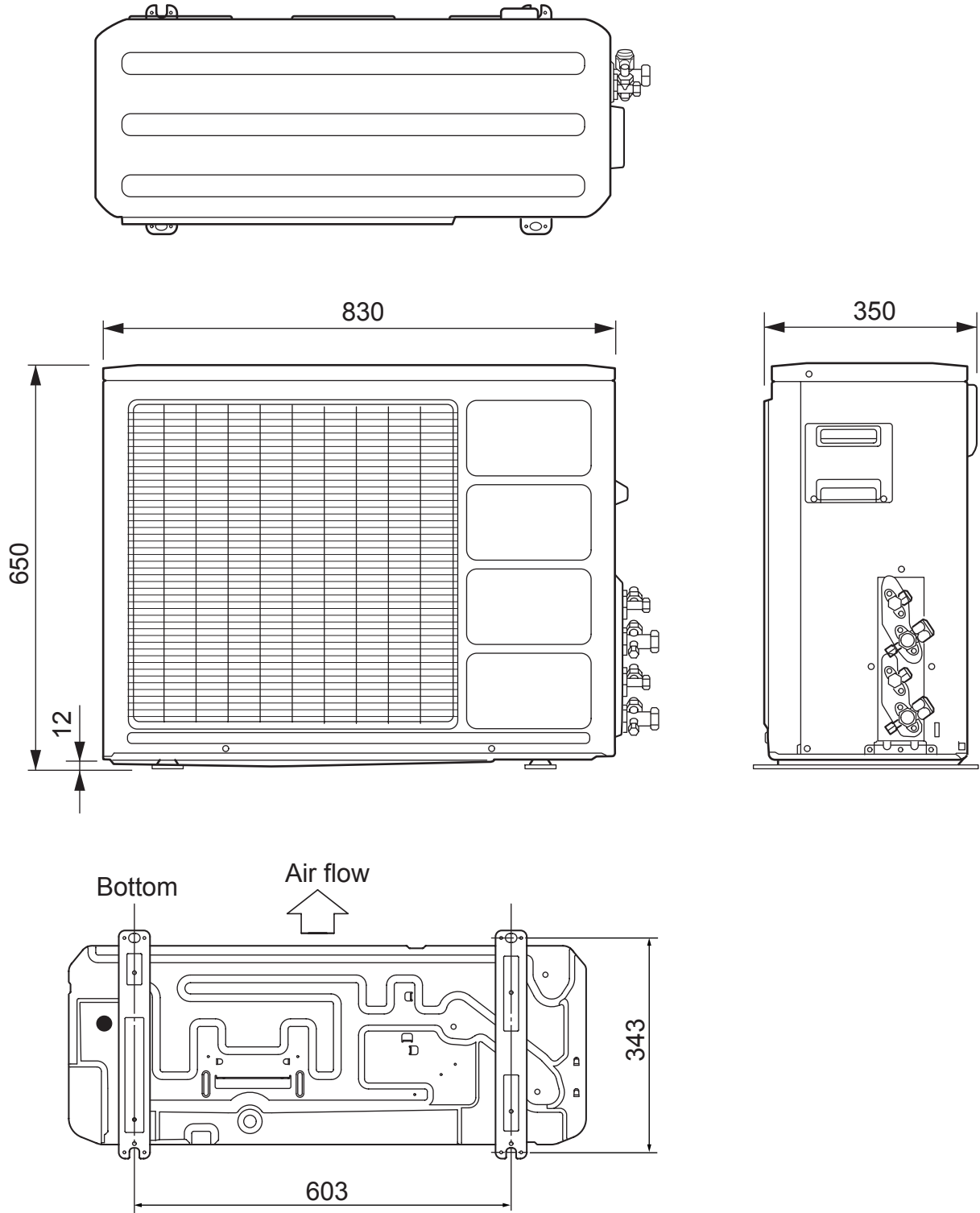

REFRIGERANT SYSTEM DIAGRAM

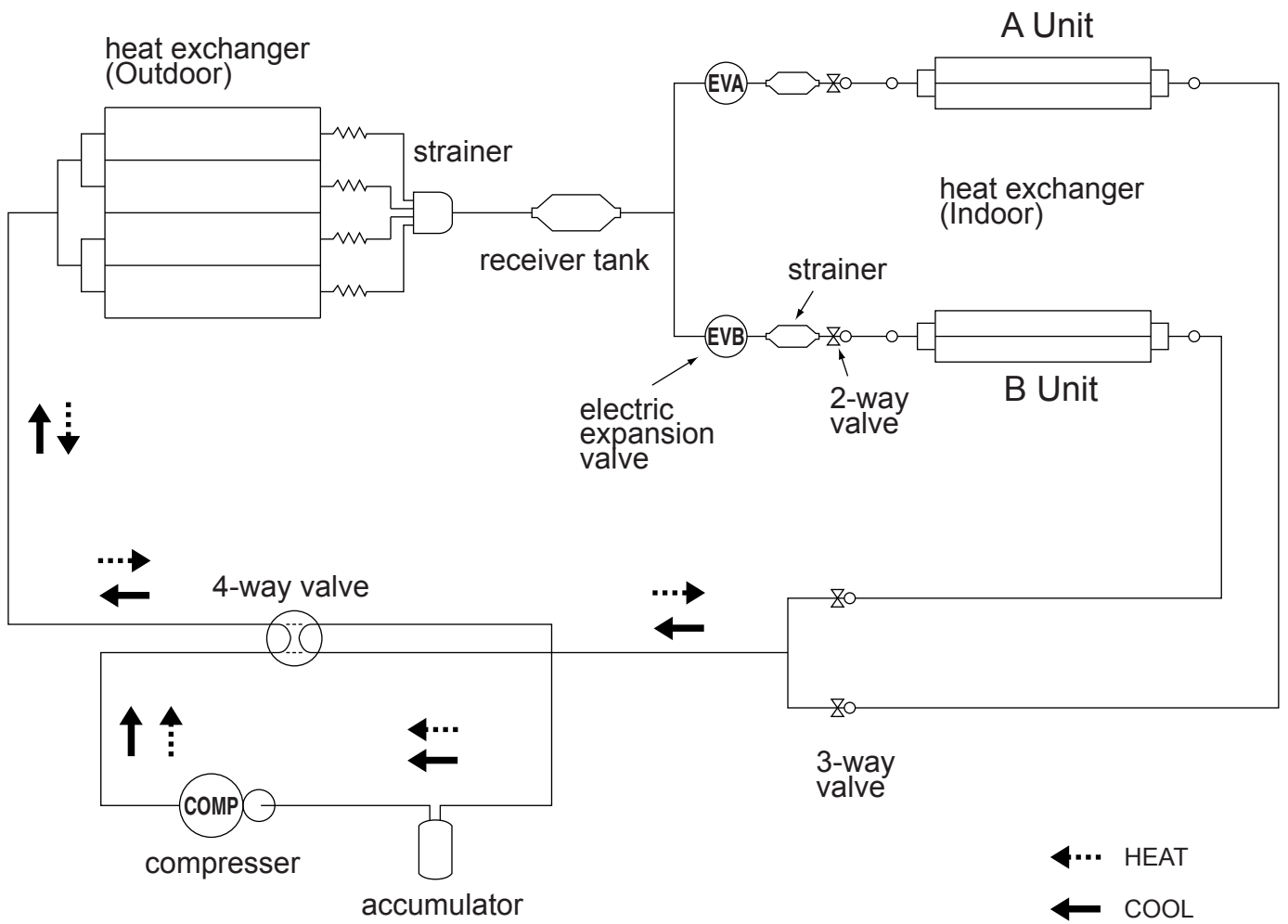

CIRCUIT DIAGRAM

INDOOR UNIT

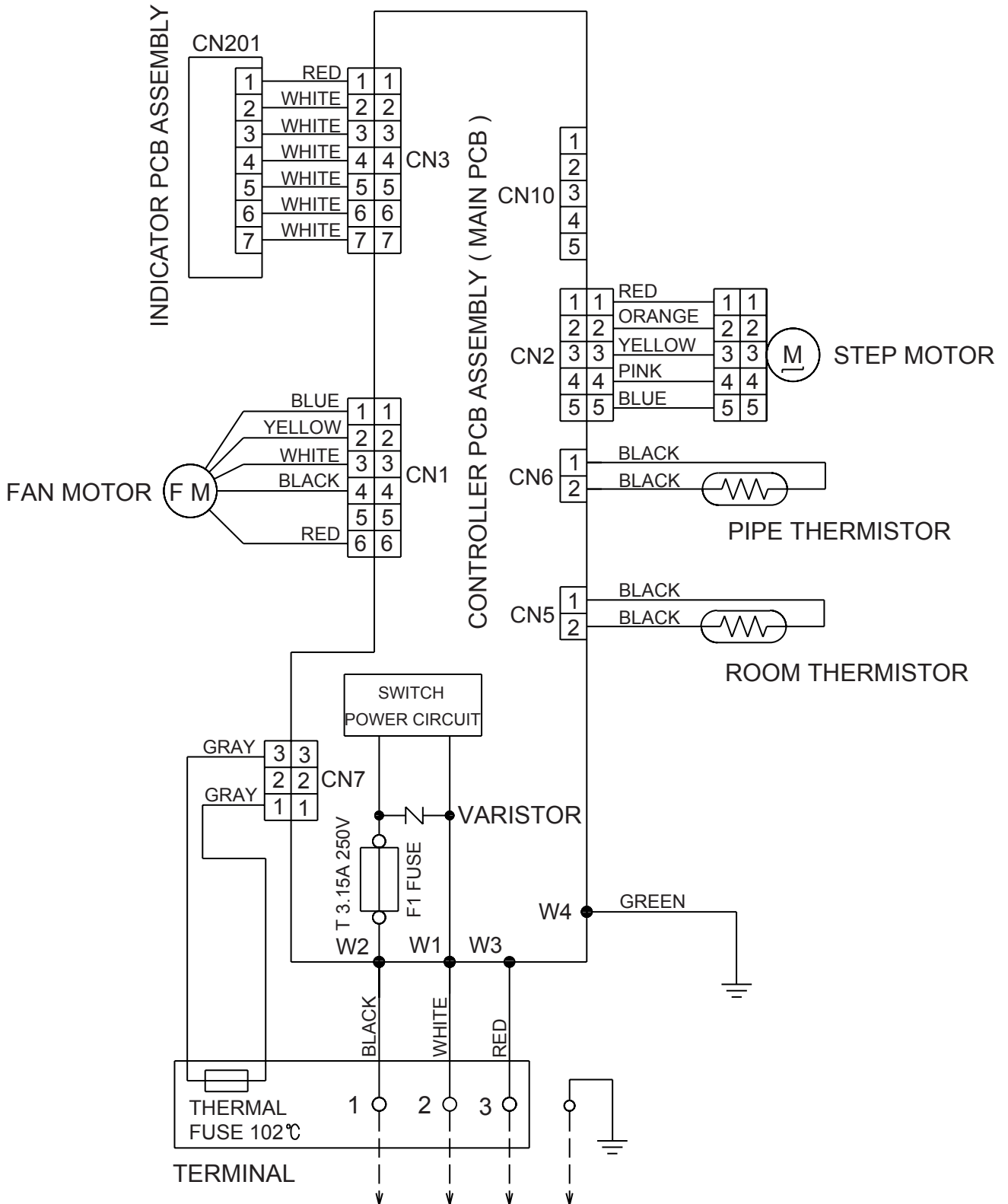

OUTDOOR UNIT

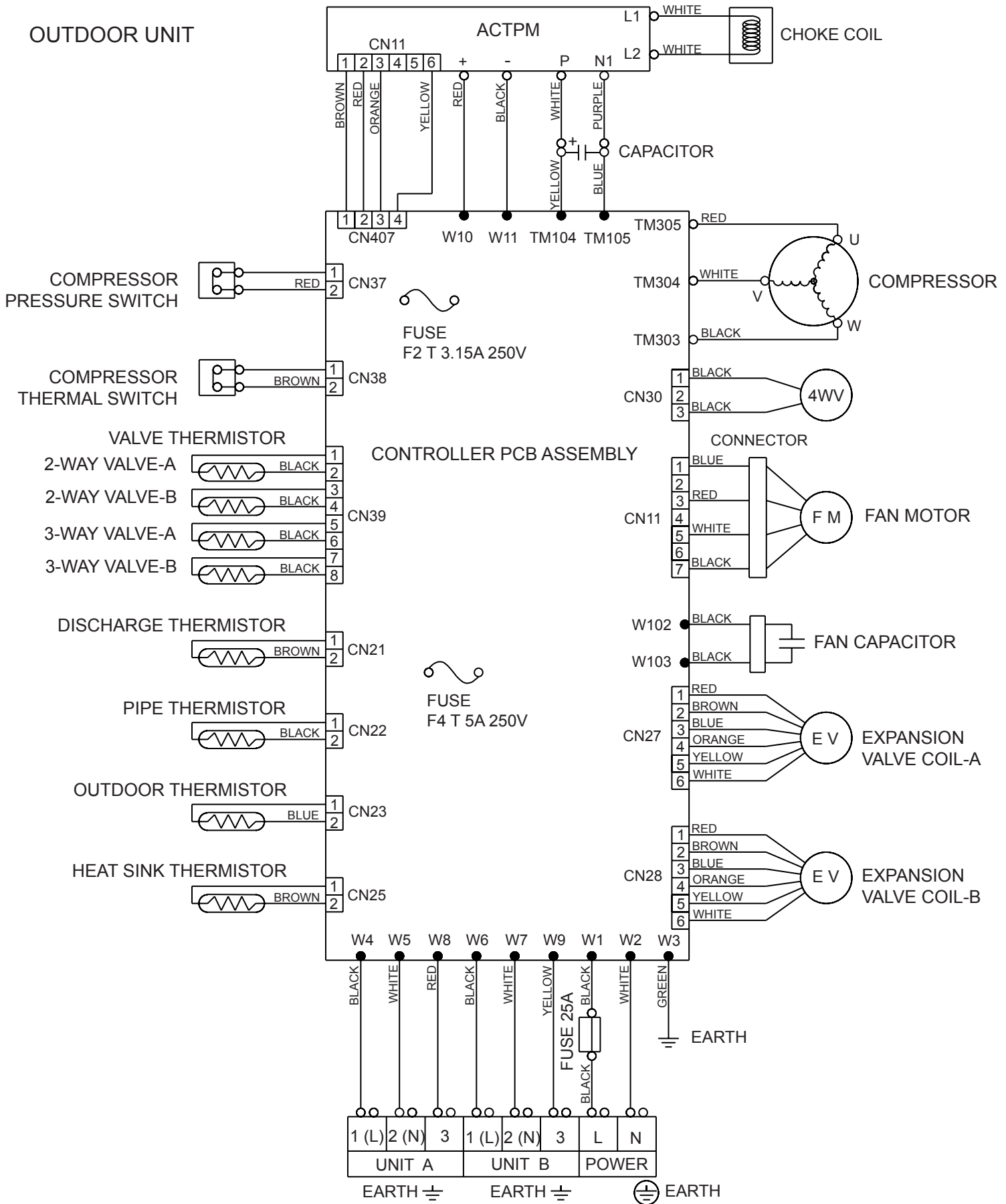

INDOOR PCB CIRCUIT DIAGRAM

CONTROL UNIT

ASYA07LACM : EZ-0070HSE

ASYA09LACM : EZ-0071HSE

ASYA12LACM : EZ-0072HSE

ASYA14LACM : EZ-006WHSE

ASYA18LACM : EZ-006YHSE

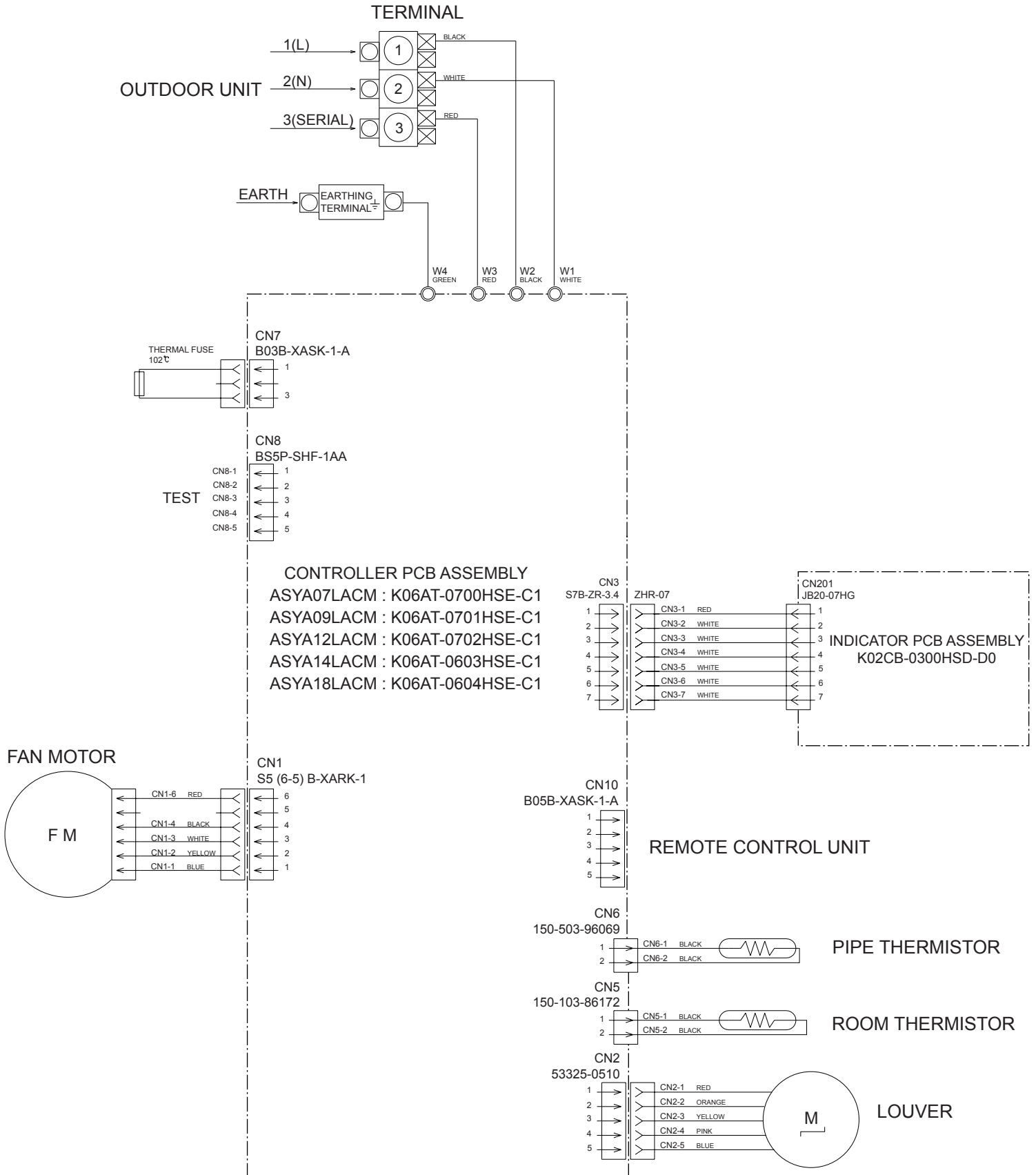

INDOOR UNIT
 CONTROLLER PCB ASSEMBLY
 ASYA07LACM : K06AT-0700HSE-C1
 ASYA09LACM : K06AT-0701HSE-C1
 ASYA12LACM : K06AT-0702HSE-C1
 ASYA14LACM : K06AT-0603HSE-C1
 ASYA18LACM : K06AT-0604HSE-C1

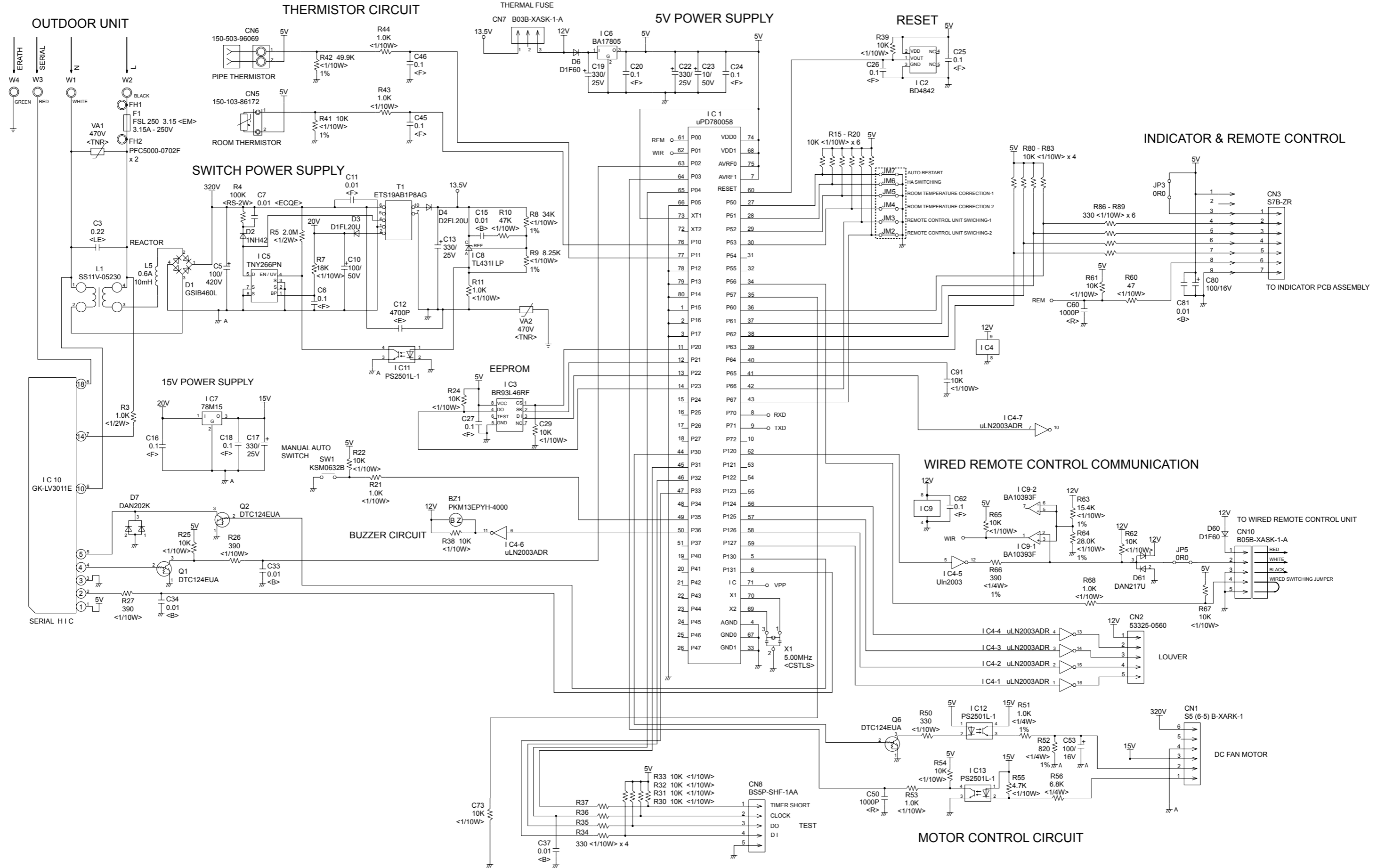

INDOOR UNIT
 INDICATOR PCB ASSEMBLY
 K02CB-0300HSD-D0

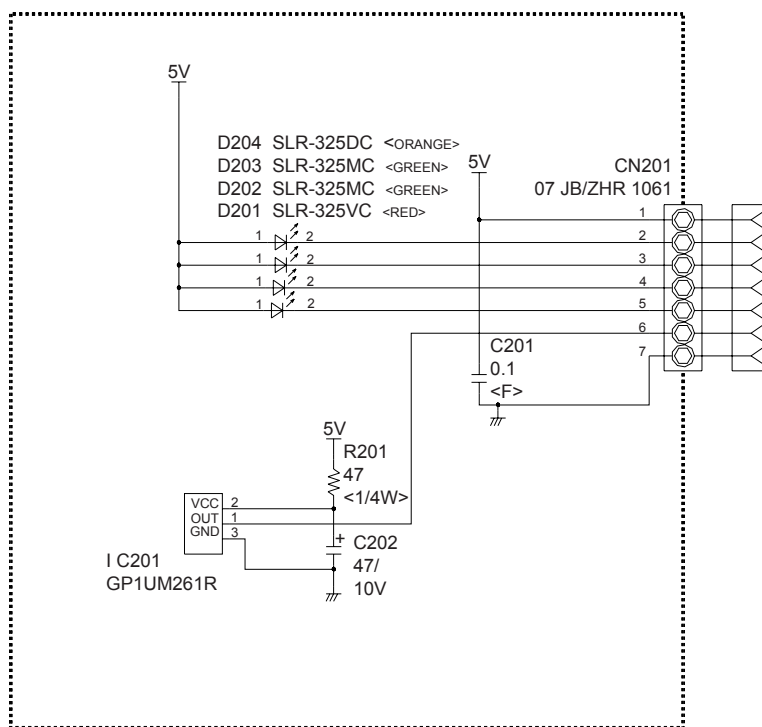

OUTDOOR PCB CIRCUIT DIAGRAM

INVERTER ASSEMBLY

AOY18LMAK2 : EZ-0056HUE

AOY24LMAM2 : EZ-0037HUE

CONTROLLER PCB ASSEMBLY

AOY18LMAK2 : K06DY-0602HUE-C1

AOY24LMAM2 : K06DY-0600HUE-C1

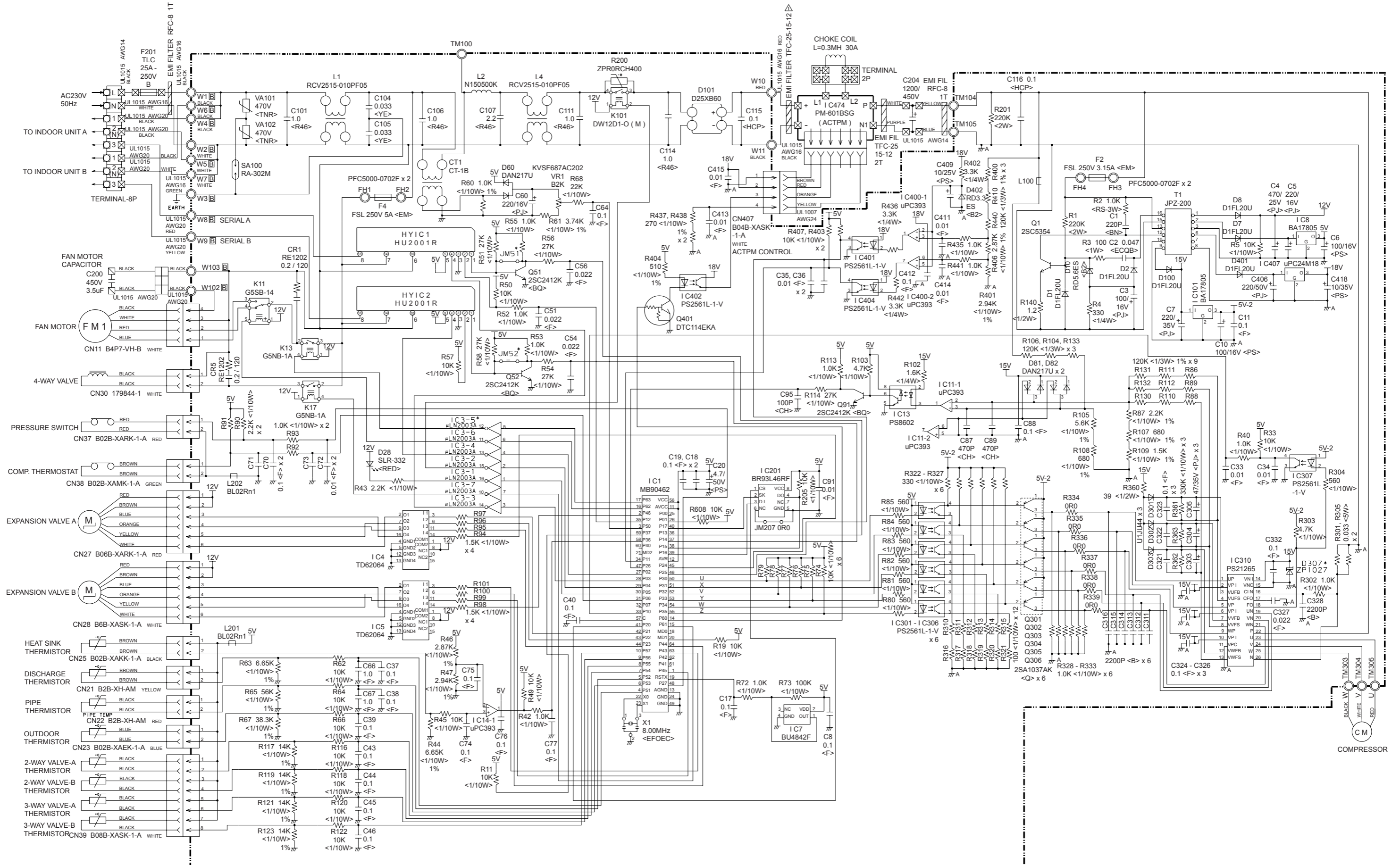

ERROR CONTENTS

INDOOR UNIT

Error contents		Error display Indoor unit LED			
		OPERATION (Red)	TIMER (Green)	AIR CLEAN or QUIET (Green)	COIL DRY (Orange)
Communication error	Indoor unit - Outdoor unit	off	2 - 5 flashes	off	off
Indoor unit temperature error	Room temp. sensor error	2 flashes	2 flashes	off	off
	Heat exchanger temp. sensor error	2 flashes	3 flashes	off	off
Outdoor unit temperature error	Discharge pipe temp. sensor error	3 flashes	2 flashes	off	off
	Heat exchanger temp. sensor error	3 flashes	3 flashes	off	off
	Outdoor temp. sensor error	3 flashes	4 flashes	off	off
	2 way valve temp. sensor error	3 flashes	off	2 flashes	off
	3 way valve temp. sensor error	3 flashes	off	3 flashes	off
	Heat sink temp. sensor error	3 flashes	7 flashes	off	off
Indoor unit control system error	Compressor temp. sensor error	3 flashes	8 flashes	off	off
	MANUAL AUTO button error	4 flashes	2 flashes	off	off
	50Hz / 60Hz distinguish error	4 flashes	4 flashes	off	off
	Electronic Air clean filter error	4 flashes	7 flashes	off	off
Outdoor unit control system error	Electronic Air clean filter error	4 flashes	8 flashes	off	off
	Current trip error	5 flashes	2 flashes	off	off
	CT error	5 flashes	3 flashes	off	off
	Compressor position error	5 flashes	5 flashes	off	off
	Fan motor error	5 flashes	6 flashes	off	off
	Connected indoor unit error	5 flashes	7 flashes	off	off
Indoor unit fan motor error	Main CPU - sub CPU communication error	5 flashes	8 flashes	off	off
	Fan motor error	6 flashes	2 flashes	off	off
Refrigerant system error	Fan motor error	6 flashes	3 flashes	off	off
	Discharge pipe temp. error	7 flashes	2 flashes	off	off
	High pressure error	7 flashes	3 flashes	off	off
Added function error	High pressure switch error	7 flashes	6 flashes	off	off
	Active filter error	8 flashes	2 - 3 flashes	off	off
Indoor unit connect error	Indoor unit model error	blinking	blinking	blinking	blinking

OUTDOOR UNIT

LED	Condition
1 flash	Communication abnormal
2 flashes	Discharge pipe thermistor abnormal
3 flashes	Heat exchanger thermistor abnormal
4 flashes	Outdoor air thermistor abnormal
5 flashes	2-way valve (A, B) thermistor abnormal
6 flashes	3-way valve (A, B) thermistor abnormal
7 flashes	Compressor thermistor abnormal
8 flashes	Pressure switch abnormal
9 flashes	Indoor units connection abnormal
10 flashes	Current trip (permanent stop)
11 flashes	CT abnormal (permanent stop)
12 flashes	Compressor location detection abnormal (permanent stop)
13 flashes	Compressor does not start (permanent stop)
14 flashes	Timer reduction

PARTS

INDOOR UNIT Front panel assy

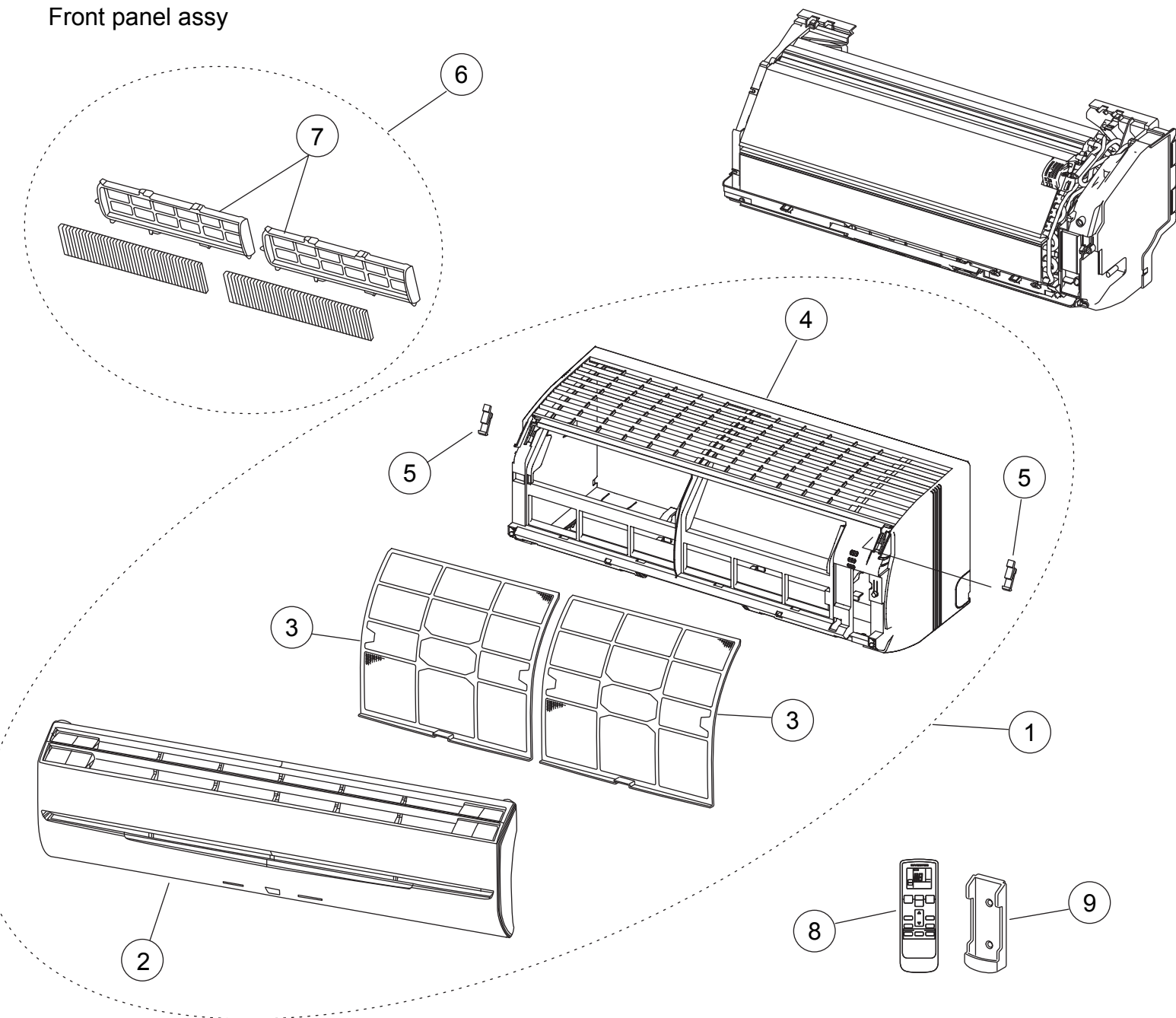

Ref.	Description	Part number	
1	Front Panel Assy	9313130169	
2	Intake Grille Assy	9313131128	
3	Air Filter	9309997011	
4	Front Panel	9309999053	
5	Clamper (Grille)	9306755010	
6	Air Clean Filter Assy	9312152018	
7	Electric Filter Holder	9306602017	
8	Remote Control Unit	9315027030	
9	Remote Control Holder	9305642045	

INDOOR UNIT
Casing assy

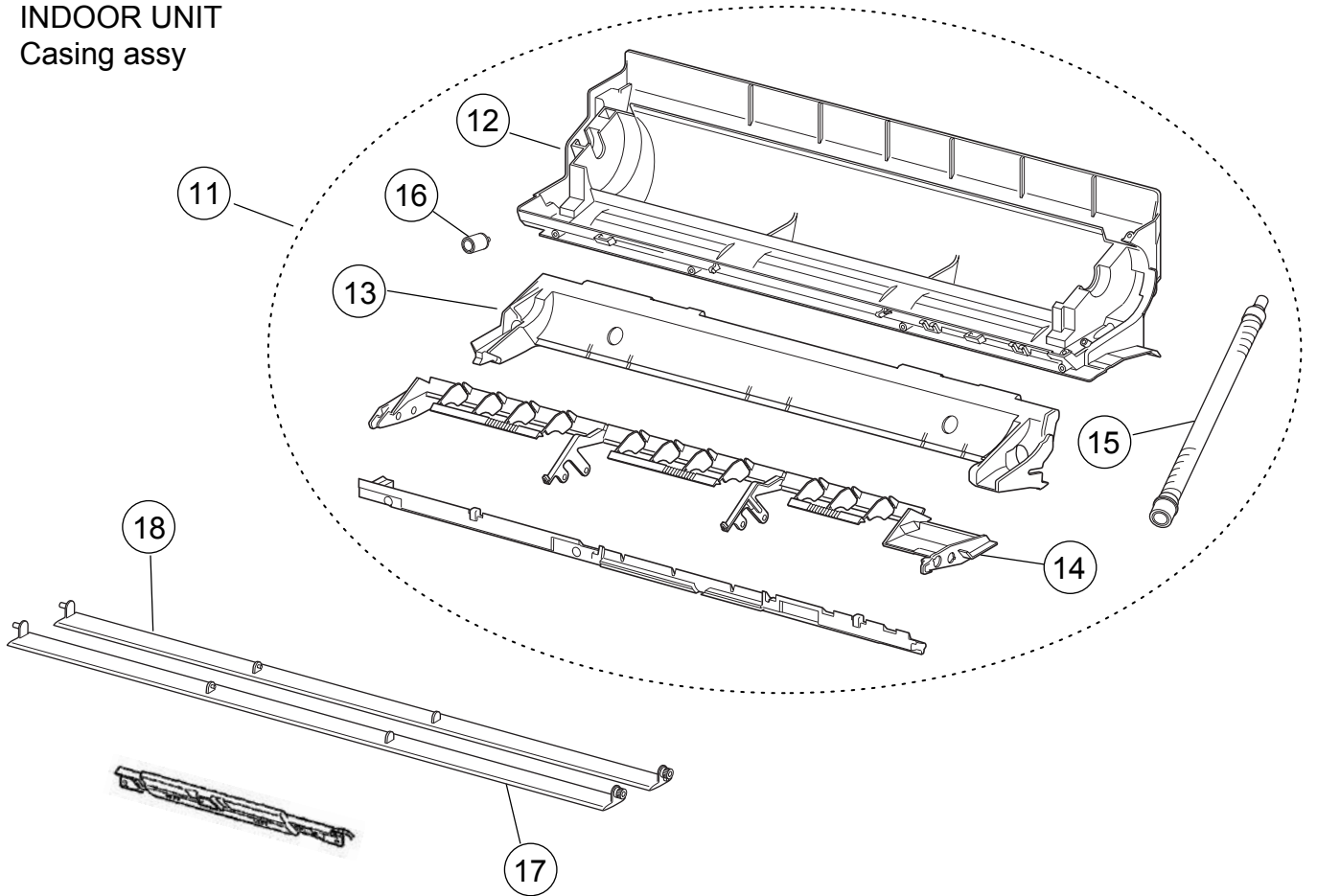

Ref.	Description	Part number	
11	Casing Assy	9311354116	
12	Casing Cover B	9314160011	
13	Casing Cover F	9309987005	
14	Louver Holder	9309993013	
15	Drain Hose Assy	9314147029	
16	Drain Cap Assy	9316177017	
17	Louver U Assy	9312368020	
18	Louver Z Assy	9312369027	

INDOOR UNIT

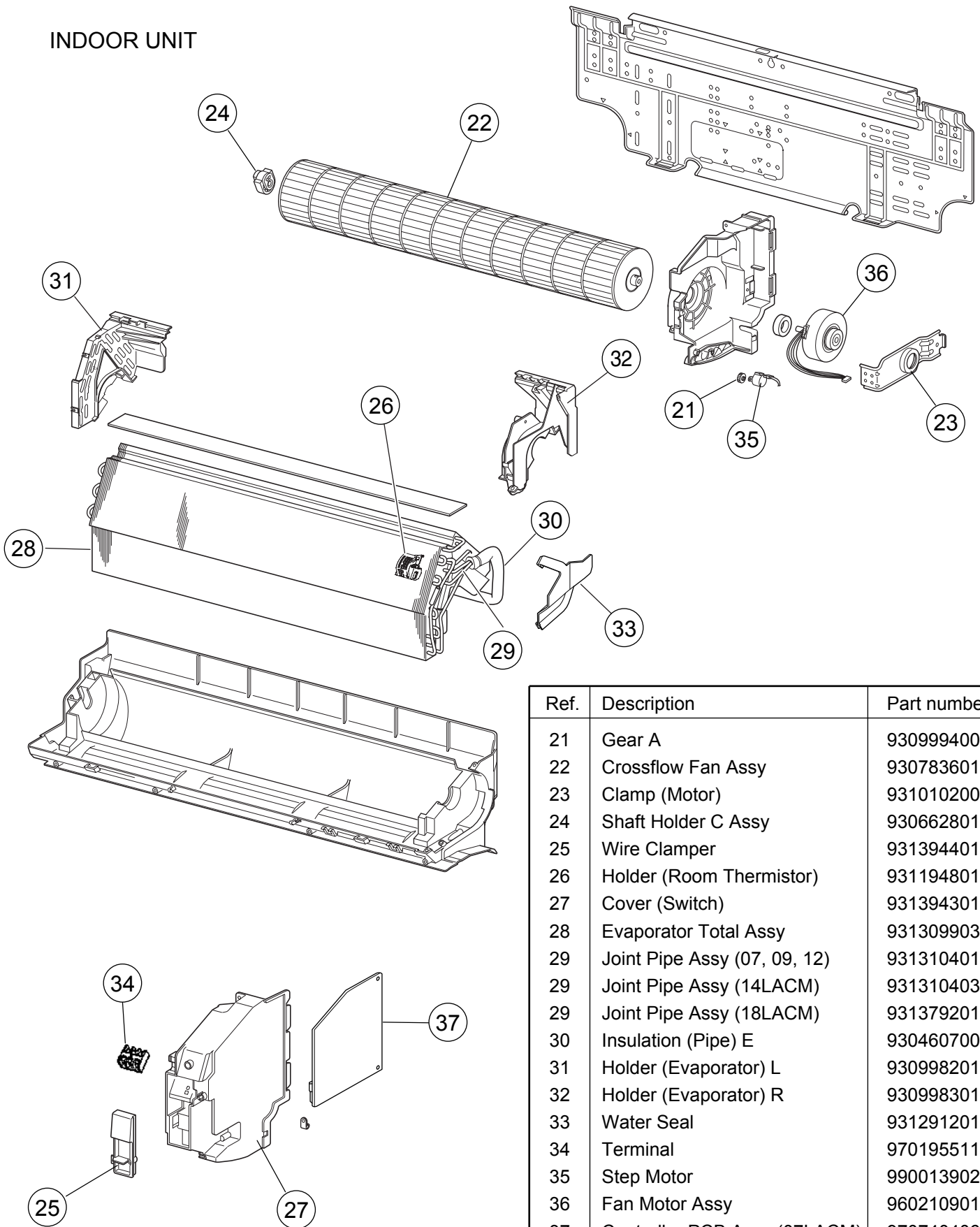

Ref.	Description	Part number
21	Gear A	9309994003
22	Crossflow Fan Assy	9307836015
23	Clamp (Motor)	9310102008
24	Shaft Holder C Assy	9306628017
25	Wire Clamper	9313944018
26	Holder (Room Thermistor)	9311948018
27	Cover (Switch)	9313943011
28	Evaporator Total Assy	9313099039
29	Joint Pipe Assy (07, 09, 12)	9313104016
29	Joint Pipe Assy (14LACM)	9313104030
29	Joint Pipe Assy (18LACM)	9313792015
30	Insulation (Pipe) E	9304607007
31	Holder (Evaporator) L	9309982017
32	Holder (Evaporator) R	9309983014
33	Water Seal	9312912018
34	Terminal	9701955114
35	Step Motor	9900139025
36	Fan Motor Assy	9602109012
37	Controller PCB Assy (07LACM)	9707404067
37	Controller PCB Assy (09LACM)	9707404074
37	Controller PCB Assy (12LACM)	9707404081
37	Controller PCB Assy (14LACM)	9707404043
37	Controller PCB Assy (18LACM)	9707404050
---	Pipe Thermistor	9702039042
---	Room Thermistor	9700801108
---	Indicator PCB Assy	9705039032
---	Evaporator B (18LACM only)	9311275022

PARTS

OUTDOOR UNIT

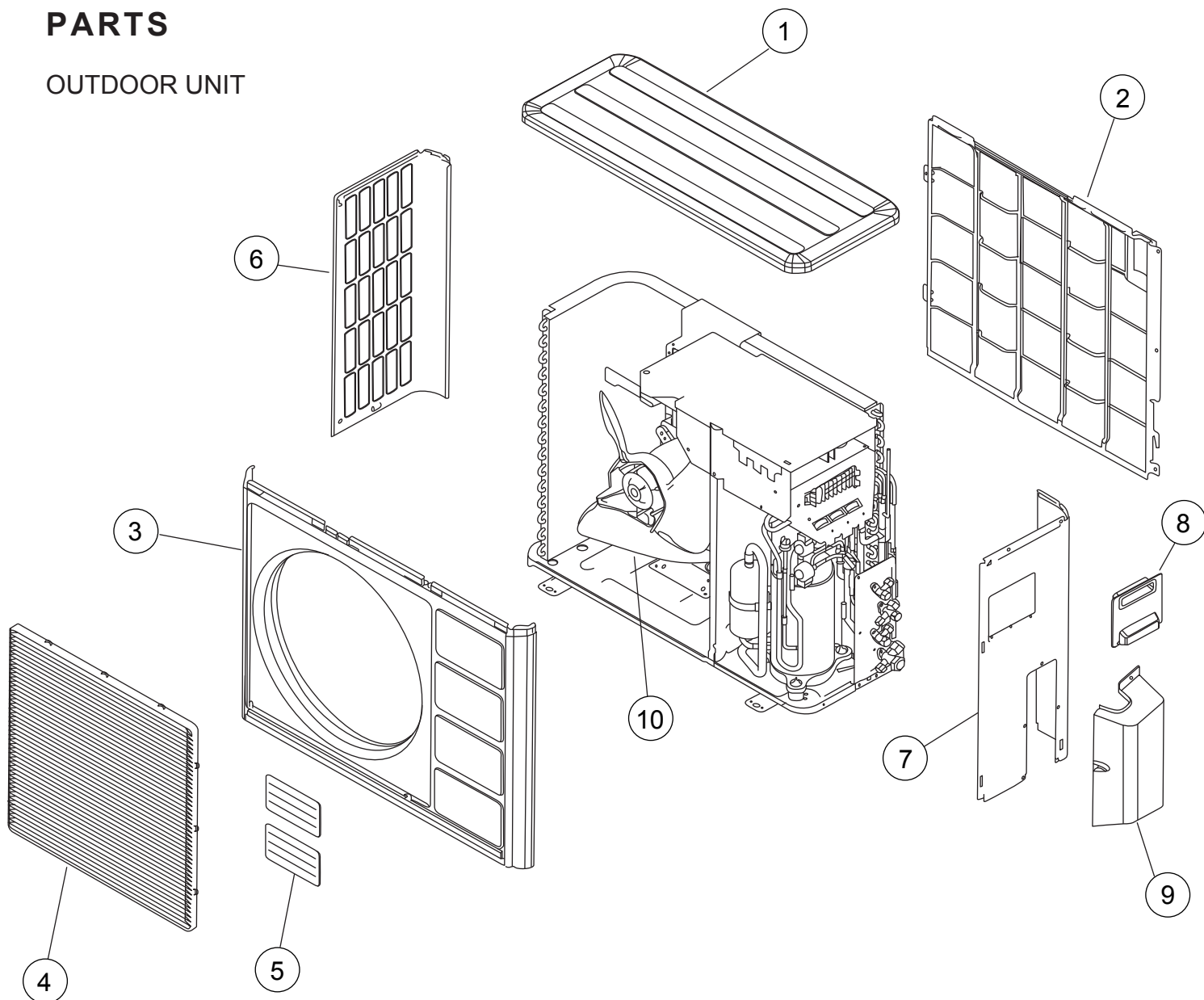

Ref.	Description	Part number
1	Top Panel	9371925011
2	Protective Net	9371934013
3	Front Panel	9371924014
4	Fan Guard	9371187013
5	Emblem	9351355005
6	Side Panel L	9371926018
7	Side Panel R Sub Assy	9372306048
8	Connecteur Cover	9366398004
9	Valve Cover	9372796016
10	Propeller Fan Assy	9366378013

OUTDOOR UNIT

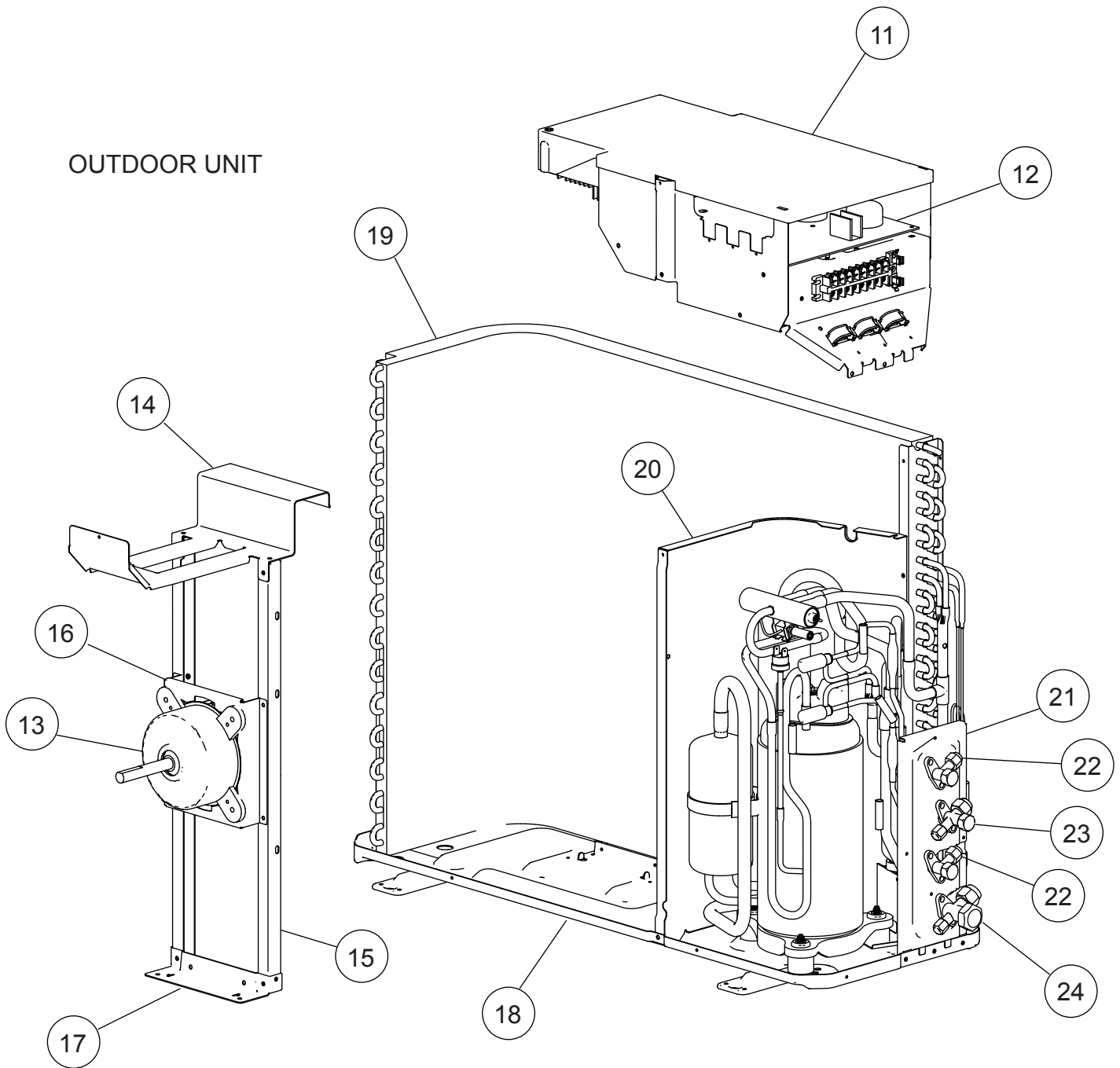

Ref.	Description	Part number	Ref.	Description	Part number
11	Control Cover	9372792018	--	Heat Exchanger Thermistor	9704220059
12	Controller PCB Assy (18LMAK2)	9707560039	--	Thermistor Outdoor	9703516047
12	Controller PCB Assy (24LMAM2)	9707560015	--	Thermistor Heat Sink	9900195014
13	Motor Induct	9601671046	--	Relay	9900117016
14	Motor Bracket Top	9371931012	--	ACTPM	9703457012
15	Motor Bracket	9371929019	--	Capacitor for PCB	9705387010
16	Motor Bracket Center	9371930015	--	Fan Capacitor	9900270049
17	Motor Bracket Bottom	9371932019	--	Fuse	0600086039
18	Base Assy	9371920078	--	Terminal 8P	9900203047
19	Condenser Assy	9372181096	--	Fuse Holder	0501454012
20	Separate Wall	9372795019	--	Terminal 2P	9701971015
21	Valve Plate	9371928036			
22	2-Way Valve	9372204054			
23	3-Way Valve	9372205044			
24	3-Way Valve	9372205051			

OUTDOOR UNIT

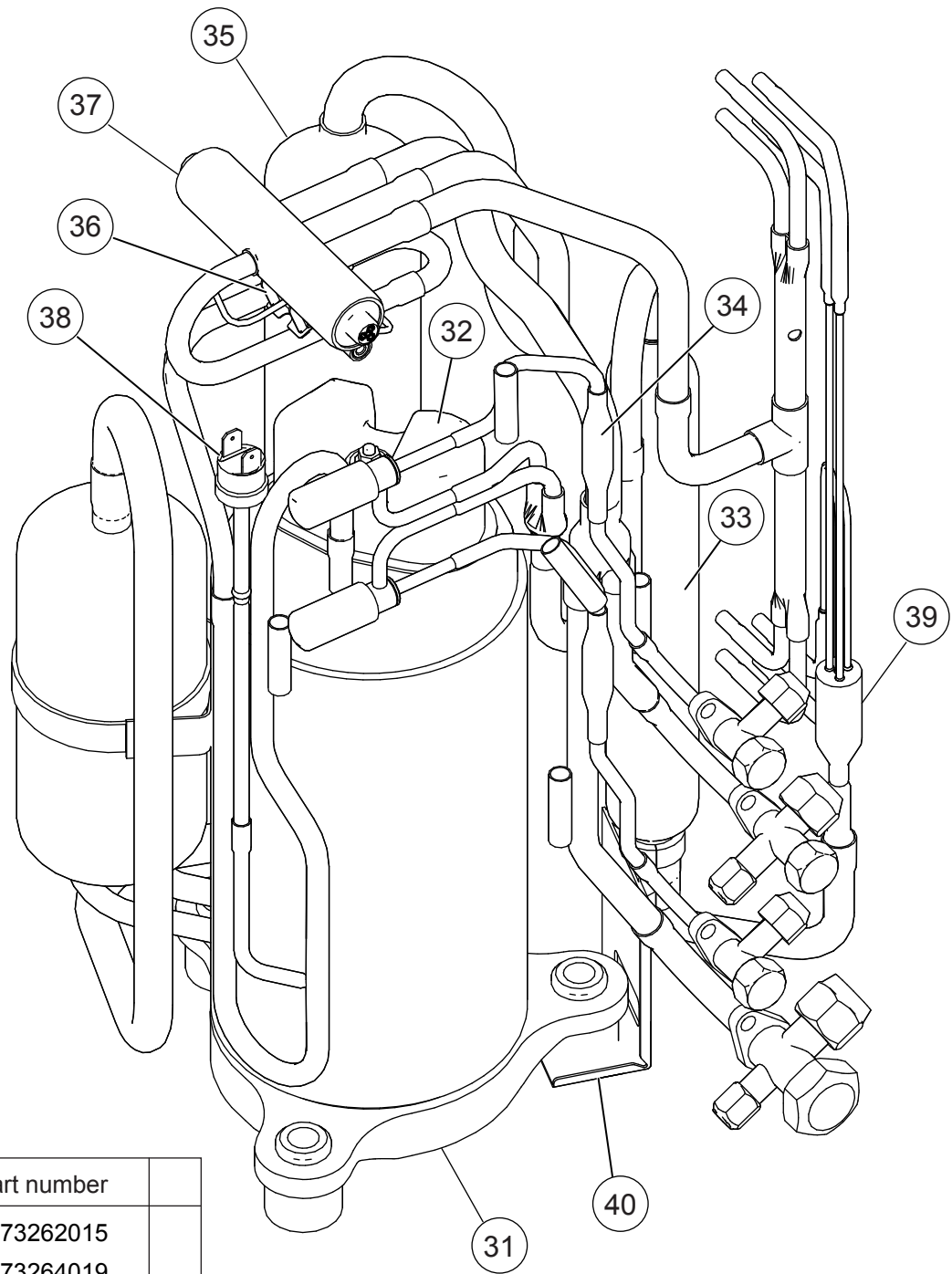

Ref.	Description	Part number
31	Compressor Assy	9373262015
32	Terminal Cover (Comp)	9373264019
33	Receiver Tank Assy	9373426011
34	Strainer Assy	9366602019
35	Accumulator	9368391003
36	Solenoid	9900165079
37	4-Way Valve	9900163013
38	Pressure Switch Assy	9373729044
39	Capillary Assy	9373729211
40	Accum Support Assy	9372252017
--	Thermal Switch	9377956019
--	Gasket (Comp)	9373266013
--	Compressor Pressure Switch	9900186012
--	Compressor Thermal Switch	9373263012
--	Thermistor Valve	9900194017
--	Thermistor Discharge	9704219039
--	Special Nut M8 (Comp)	9355091008
--	Thermister Holder Pipe	313714262805



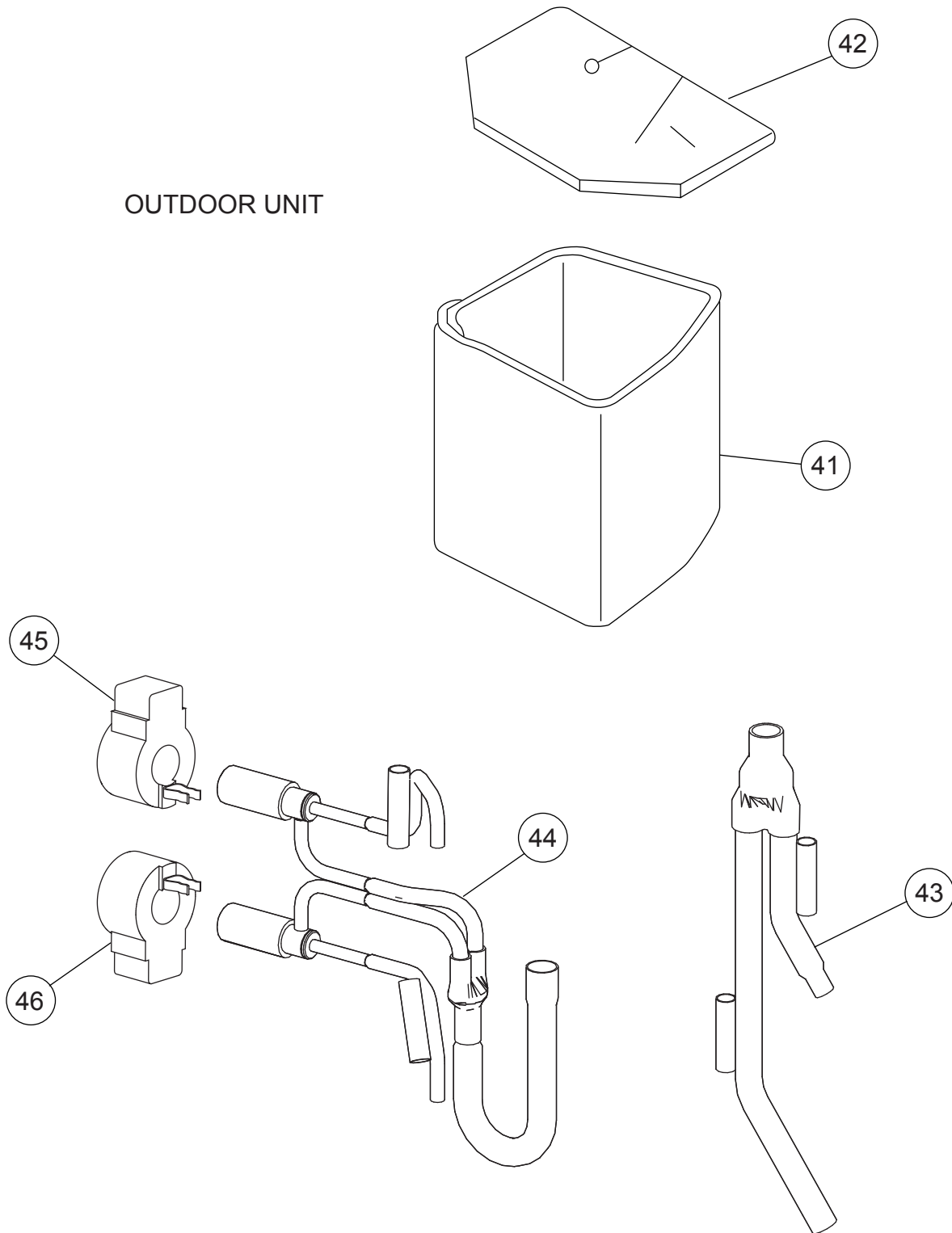



OUTDOOR UNIT

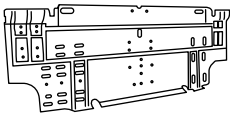

Ref.	Description	Part number
41	Compressor Cover A	9373730019
42	Compressor Cover B	9373730026
43	Joint Pipe (3Way) Assy	9373729129
44	Expansion Valve Assy	9373729068
45	Expansion Valve Coil (White connector)	9900197018
46	Expansion Valve Coil (Red connector)	9900057022

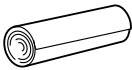
ACCESSORIES

INDOOR UNIT

Name and Shape	Q'ty	Use	Part number
Wall hook bracket 	1	To install indoor unit	9310001004
Remote control 	1	To operate air conditioner	9315027030
Battery (penlight) 	2	For remote control unit	0600185527
Cloth tape 	1	For indoor unit installation	9310519004
Remote control holder 	1	To hold remote control	9305642045
Ttpping screw (big) (ϕ 4 x 25) 	8	For wall hook bracket installation	0700076046
Ttpping screw (small) (ϕ 3 x 12) 	2	For remote control unit holder installation	0700019036

OUTDOOR UNIT

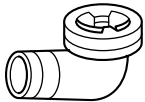
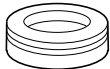
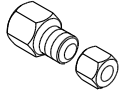
Name and Shape	Q'ty	Use	Part number
Drain pipe 	1	For outdoor unit drain piping work	9303029015
Drain cap 	1		313166024302
Adapter assy 12.7 mm \rightarrow 9.52 mm (1/2 in.) (3/8 in.) 	1	For use when connecting models 9-12 to outdoor port A	9370244007

0703G3213