

SPLIT TYPE  
AIR CONDITIONER  
CEILING TYPE (50Hz)

# SERVICE MANUAL



Indoor unit	Outdoor unit
ABYG36LRTA	AOYG36LATT
ABYG45LRTA	AOYG45LATT
ABYG54LRTA	AOYG54LATT

## CONTENTS

SPECIFICATIONS .....	1
DIMENSIONS .....	2
REFRIGERANT SYSTEM DIAGRAM .....	4
CIRCUIT DIAGRAM .....	5
INDOOR PCB CIRCUIT DIAGRAM .....	6
OUTDOOR PCB CIRCUIT DIAGRAM .....	10
ERROR DETECTION .....	17
PARTS (INDOOR UNIT) .....	21
PARTS (OUTDOOR UNIT) .....	26
ACCESSORIES .....	29

# SPECIFICATIONS

## ELECTRICAL DATA

TYPE		Cooling & Heating		
INDOOR UNIT		ABYG36LRTA	ABYG45LRTA	ABYG54LRTA
OUTDOOR UNIT		AOYG36LATT	AOYG45LATT	AOYG54LATT
COOLING CAPACITY		10.0 kW	12.5 kW	14.0 kW
HEATING CAPACITY		11.2 kW	14.0 kW	16.0 kW
POWER SOURCE		400 V, 50 Hz, 3 phase, 4 W		
RUNNING CURRENT	Cooling	4.3 A	5.8 A	6.9 A
	Heating	4.4 A	5.8 A	6.9 A
INPUT WATTS	Cooling	2.84 kW	3.89 kW	4.65 kW
	Heating	2.87 kW	3.88 kW	4.67 kW
E.E.R.	Cooling	3.52 kW/kW	3.21 kW/kW	3.01 kW/kW
C.O.P.	Heating	3.90 kW/kW	3.61 kW/kW	3.43 kW/kW
MOISTURE REMOVAL		3.0 L/hr	4.5 L/hr	5.0 L/hr
AIRCIRCULATION INDOOR		1,900 m3/h	2,100 m3/h	2,300 m3/h
AIRCIRCULATION OUTDOOR	Cooling	6,200 m3/h	6,750 m3/h	6,900 m3/h
	Heating	6,200 m3/h	6,200 m3/h	6,900 m3/h
MAXIMUM CURRENT		7.9 A	8.9 A	9.9 A

## FAN MOTOR

INDOOR UNIT, Discrimination		MFH-45RV		
INDOOR UNIT	High	1,100 r.p.m.	1,200 r.p.m.	1,360 r.p.m.
	Medium	910 r.p.m.	1,000 r.p.m.	1,150 r.p.m.
	Low	750 r.p.m.	830 r.p.m.	950 r.p.m.
	Quiet	650 r.p.m.	680 r.p.m.	790 r.p.m.
OUTDOOR UNIT, Discrimination		MFE-54VVT		
OUTDOOR UNIT Cooling	Upper fan	780 r.p.m.	850 r.p.m.	900 r.p.m.
	Lower fan	750 r.p.m.	800 r.p.m.	800 r.p.m.
OUTDOOR UNIT Heating	Upper fan	780 r.p.m.	780 r.p.m.	870 r.p.m.
	Lower fan	750 r.p.m.	750 r.p.m.	840 r.p.m.

## NOISE LEVEL

INDOOR UNIT	High	47 dB	49 dB	51 dB
	Medium	43 dB	45 dB	48 dB
	Low	37 dB	39 dB	42 dB
	Quiet	32 dB	34 dB	38 dB
OUTDOOR UNIT	Cooling	51 dB	54 dB	55 dB
	Heating	53 dB	54 dB	56 dB

## COMPRESSOR AND REFRIGERANT

TYPE		Hermetic type, Inverter, 4 poles, 3 phase, DC motor, Twin Rotary	
DISCRIMINATION		DA422A3F-29ZAD	
WEIGHT (with oil)		23.0 kg	
REFRIGERANT TYPE		R410A	
PRECHARGED REFRIGERANT		3,450 g	
MAX PIPE HEIGHT		30 m	
FULL CHARGE	Pipe length	30 m	3,450 g
		45 m	4,200 g
		60 m	4,950 g
		75 m	5,700 g
ADDITIONAL CHARGE		50 g/m	

## DIMENSIONS

INDOOR UNIT	H x W x D	240 x 1,660 x 700 mm
OUTDOOR UNIT	H x W x D	1,290 x 900 x 330 mm

## WEIGHT

INDOOR UNIT	Shipping / Net	58 kg / 46 kg	60 / 48
OUTDOOR UNIT	Shipping / Net	113 kg / 104 kg	

# DIMENSIONS

INDOOR UNIT  
(Unit : mm)

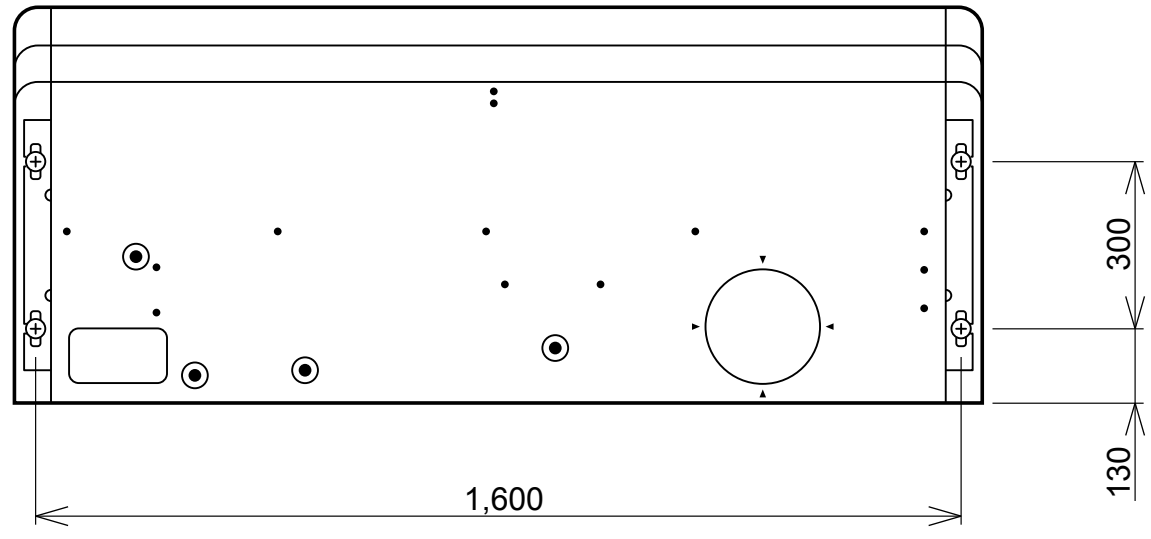
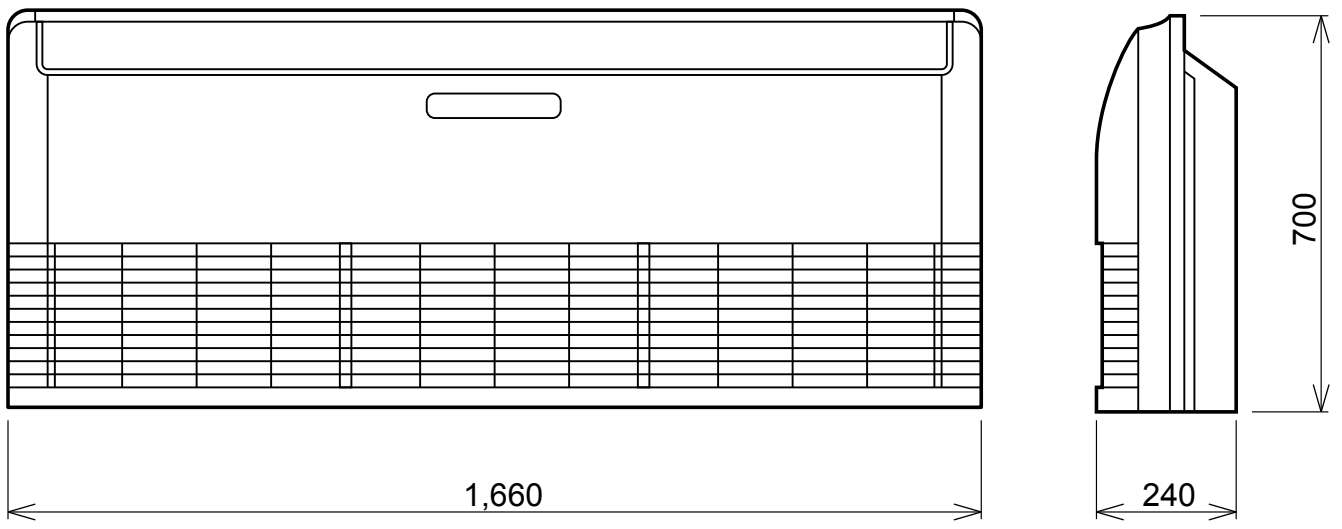

OUTDOOR UNIT  
(unit : mm)

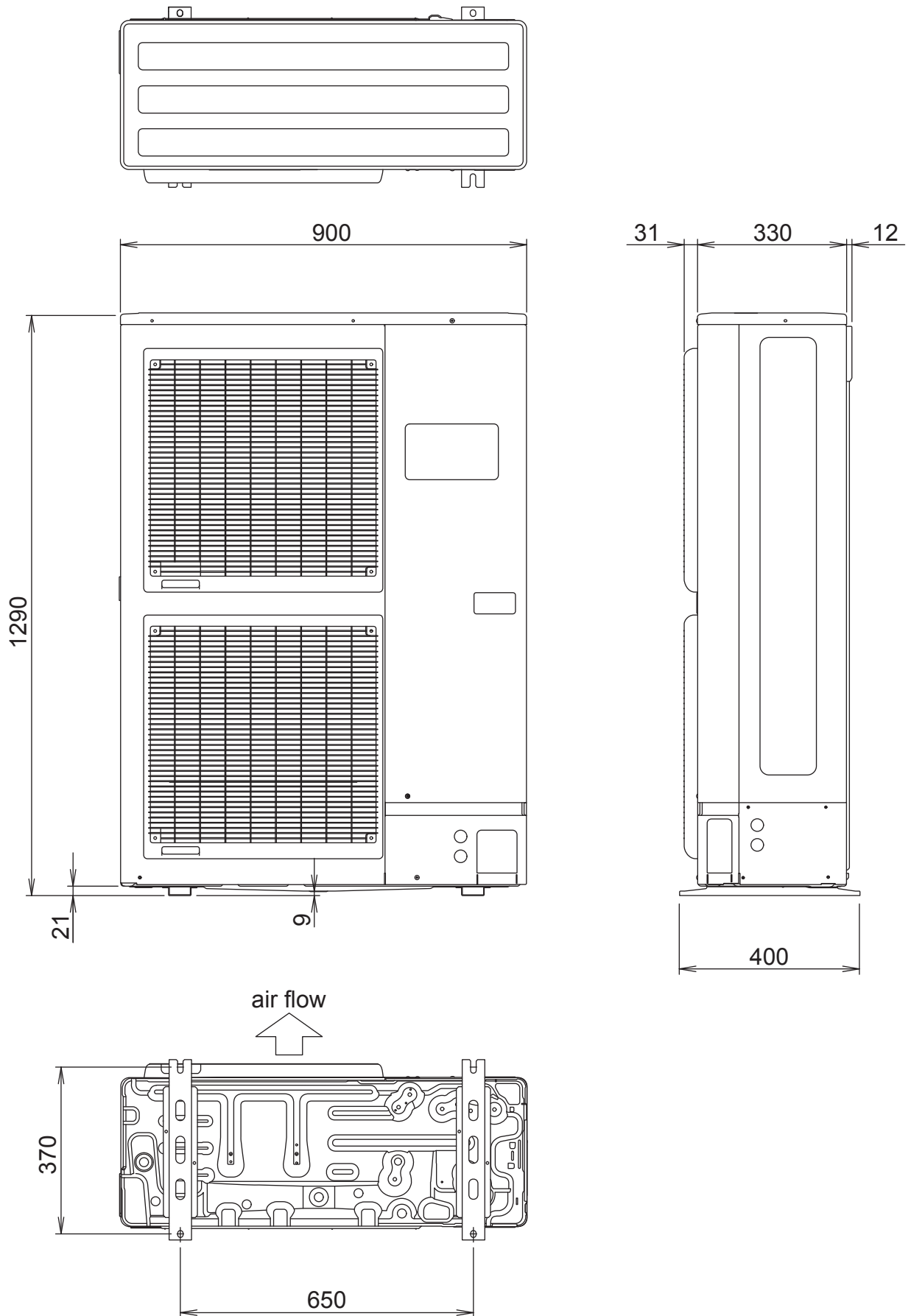



# CIRCUIT DIAGRAM

## OUTDOOR UNIT

### INDOOR UNIT

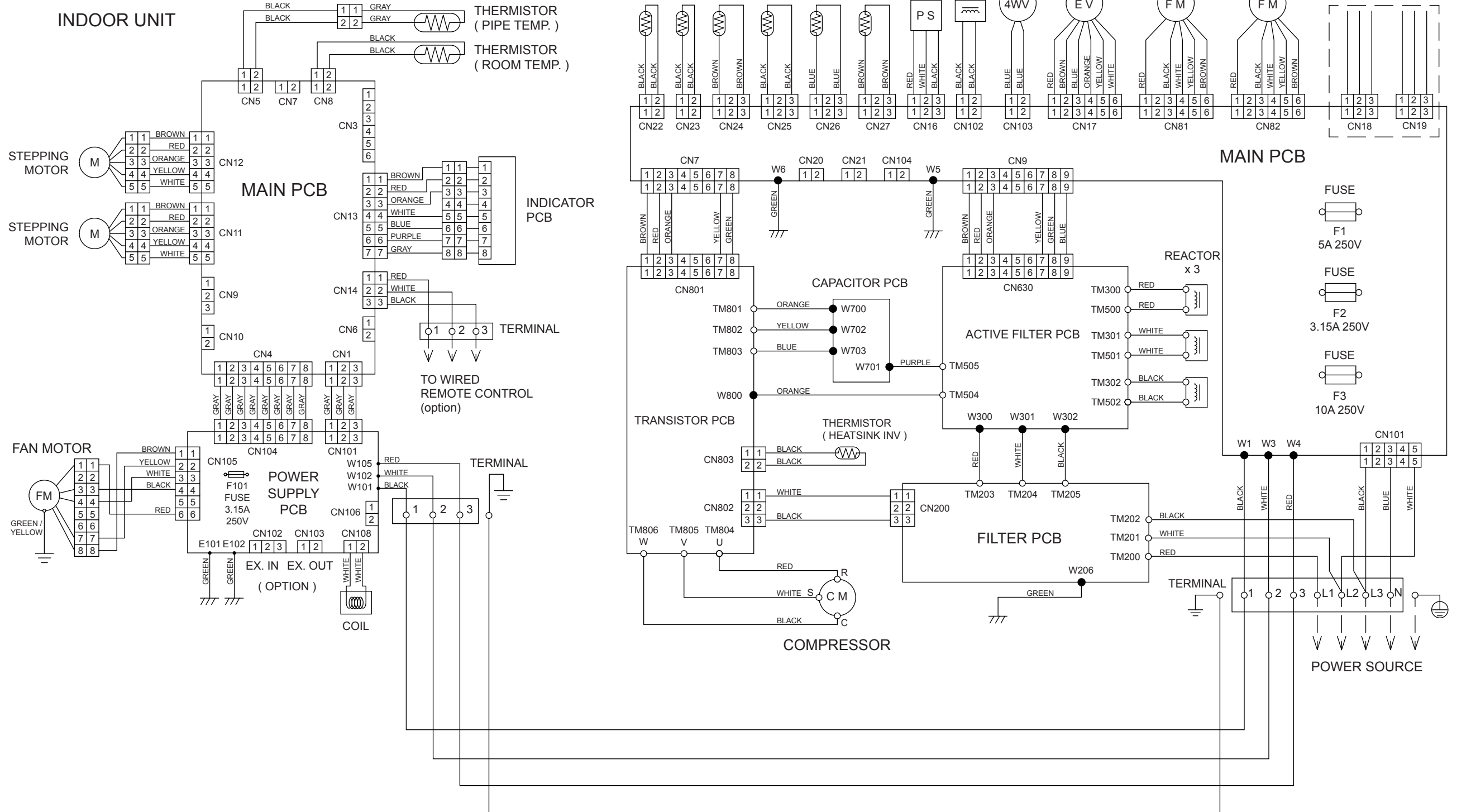



INDOOR UNIT

MAIN PCB

ABYG36LRTA : K06AK-1212HSE-C1

ABYG45LRTA : K06AK-1213HSE-C1

ABYG54LRTA : K06AK-121GHSE-C1

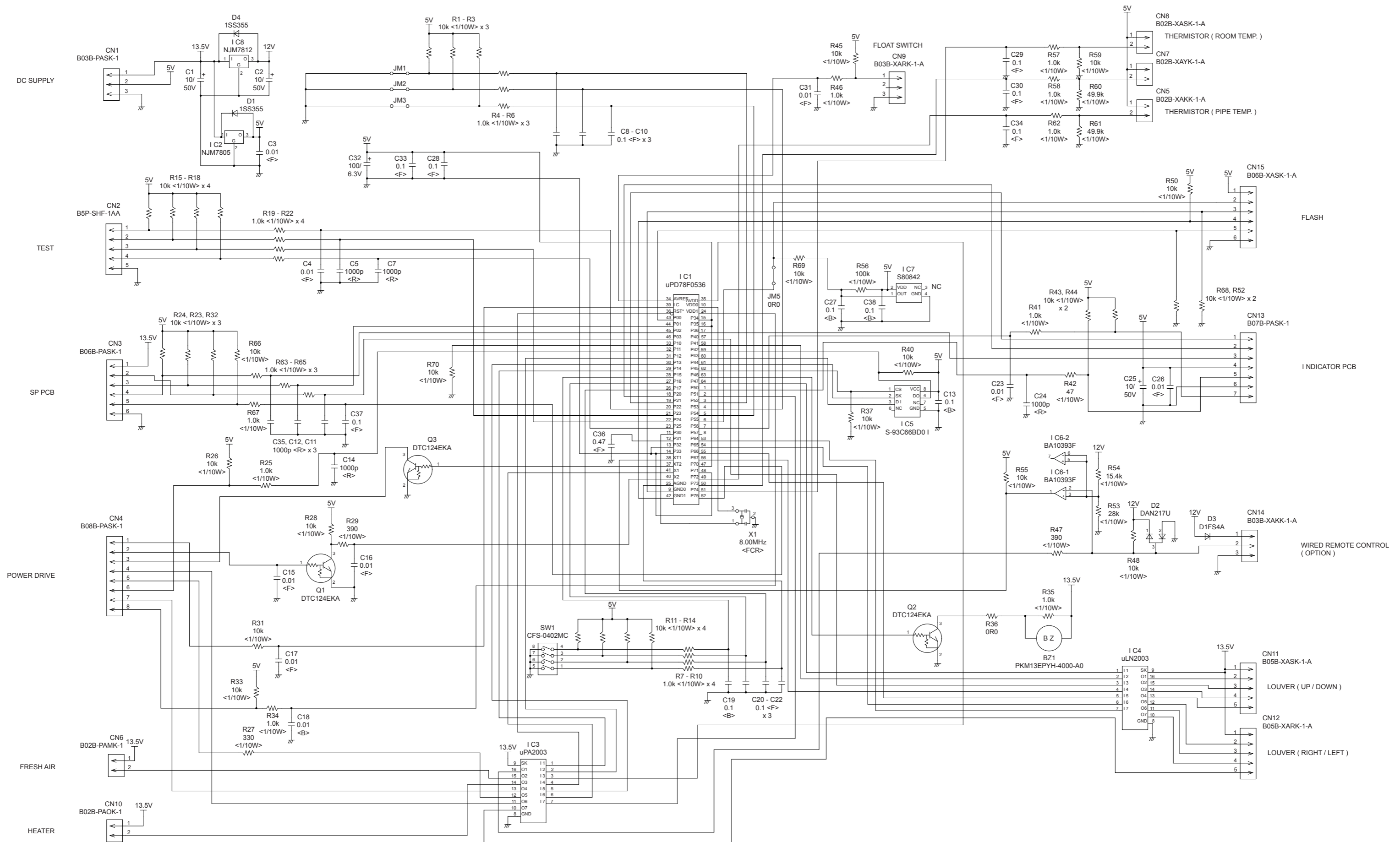



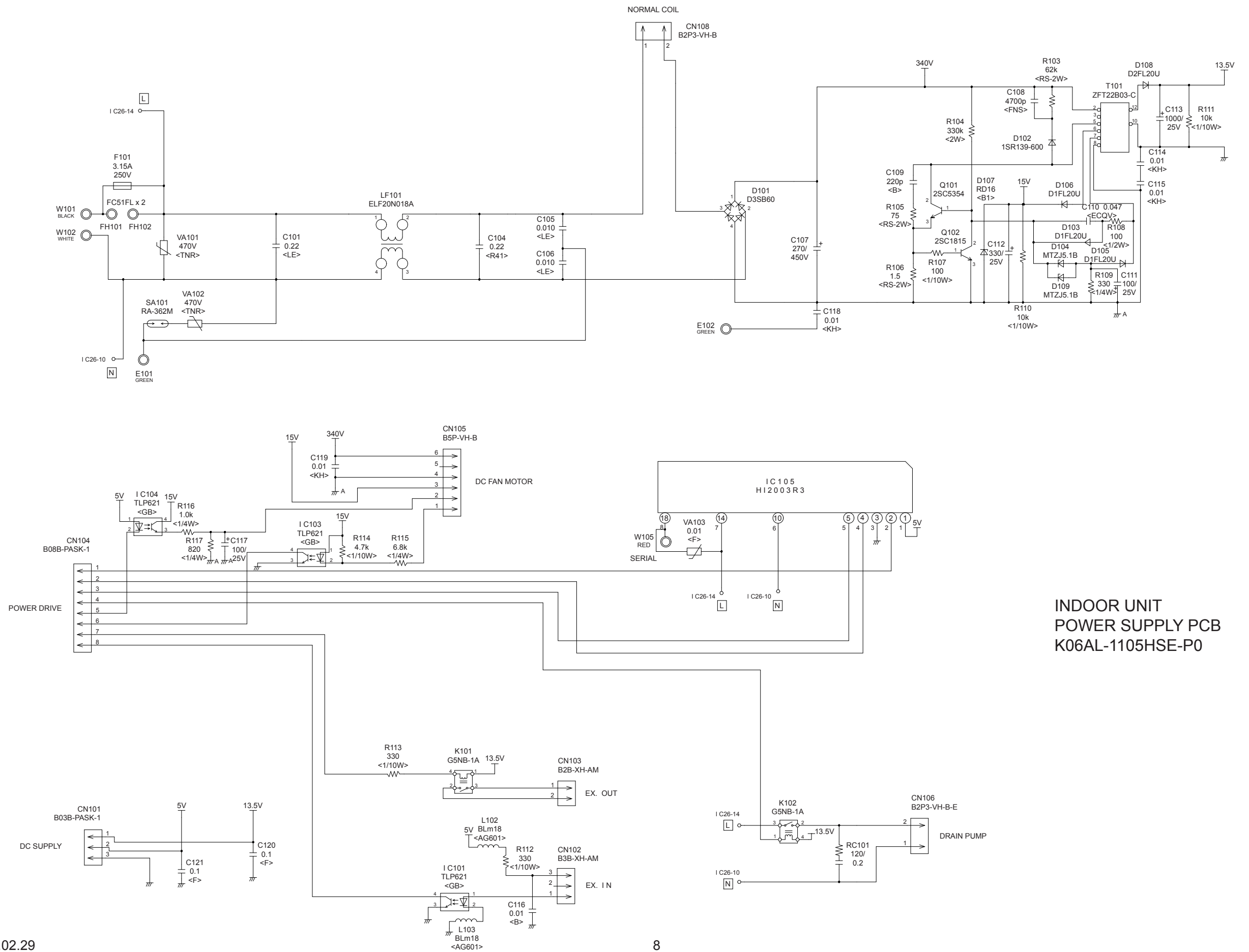

**INDOOR UNIT  
POWER SUPPLY PCB  
K06AL-1105HSE-P0**

INDOOR UNIT  
INDICATOR PCB  
K04GN1100HSE-D0

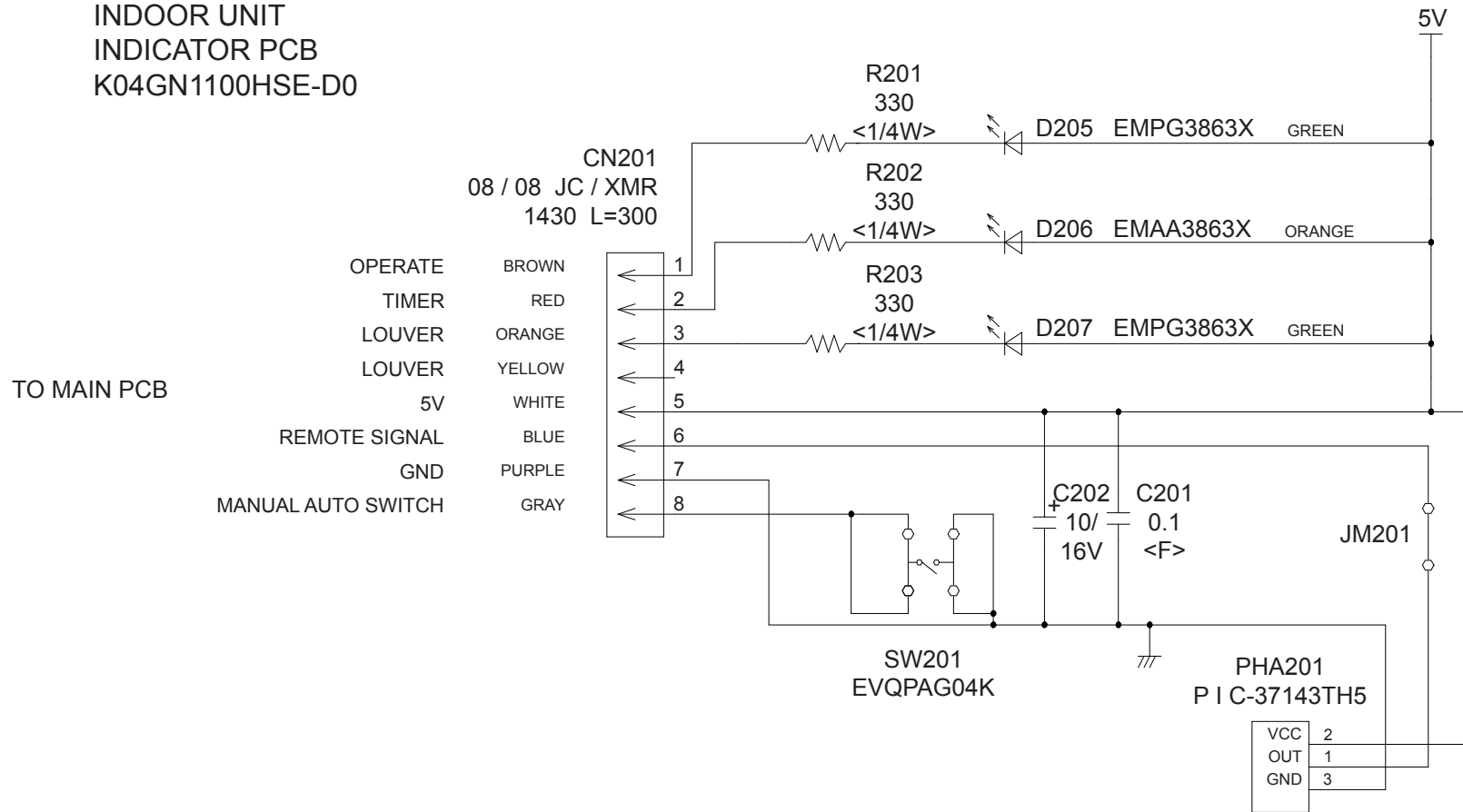

# OUTDOOR PCB CIRCUIT DIAGRAM

## INVERTER ASSEMBLY

AOYG36LATT : EZ-01222HUE

AOYG45LATT : EZ-0111WHUE

AOYG54LATT : EZ-0111YHUE

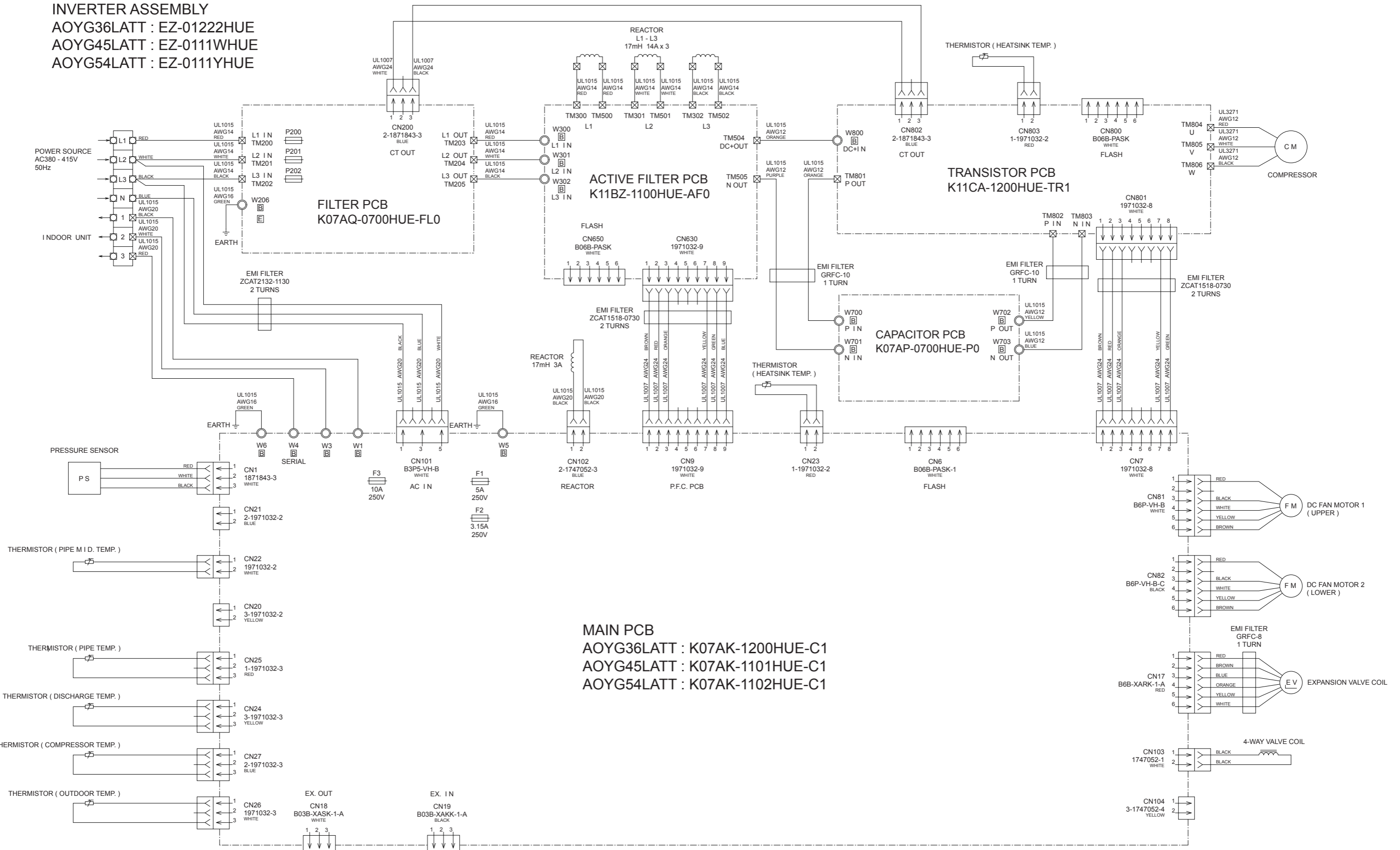

**OUTDOOR UNIT  
MAIN PCB**  
 AOYG36LATT : K07AK-1200HUE-C1  
 AOYG45LATT : K07AK-1101HUE-C1  
 AOYG54LATT : K07AK-1102HUE-C1

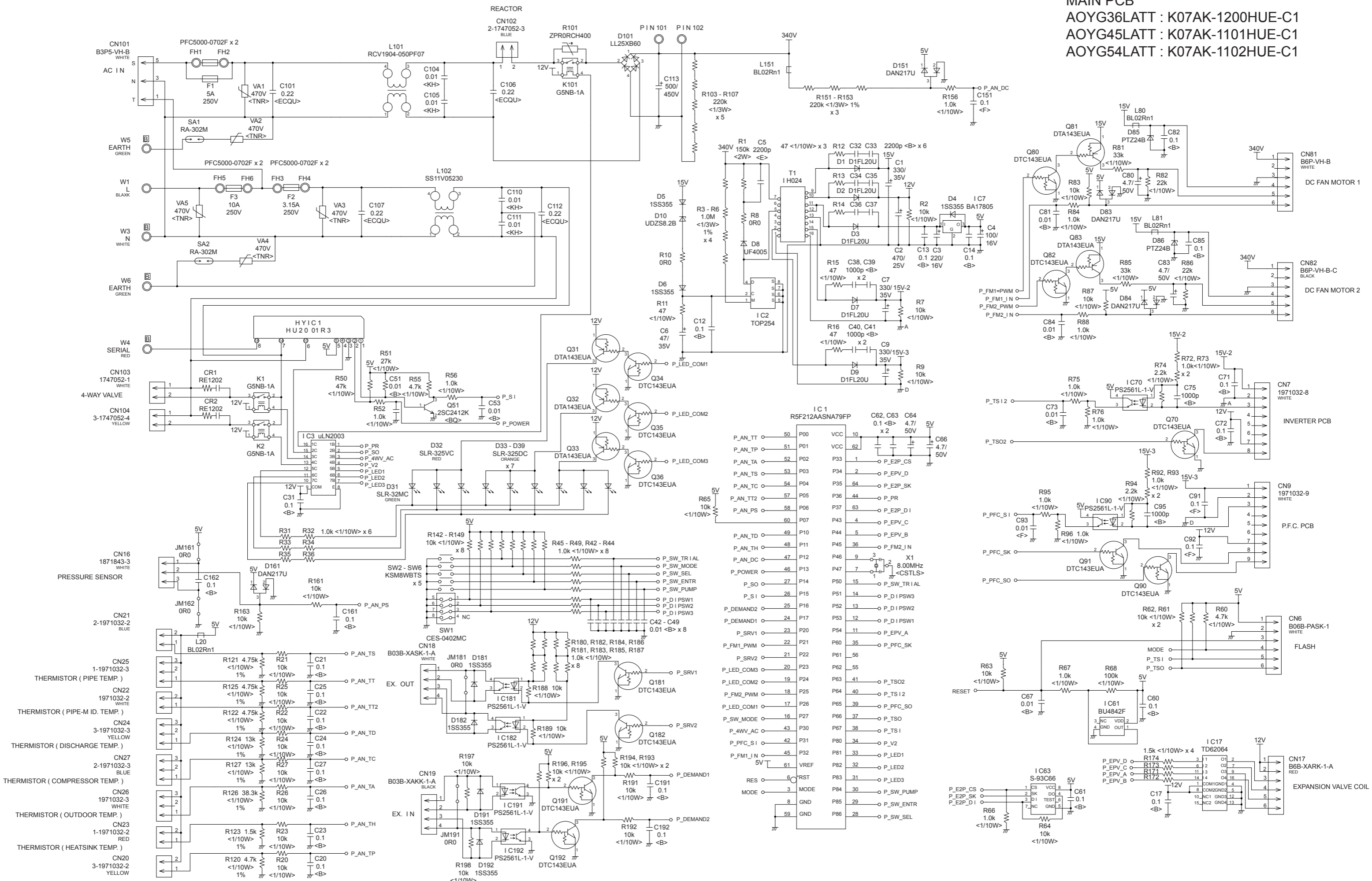



OUTDOOR UNIT  
ACTIVE FILTER PCB - 1  
K-11BZ-1100HUE-AF0

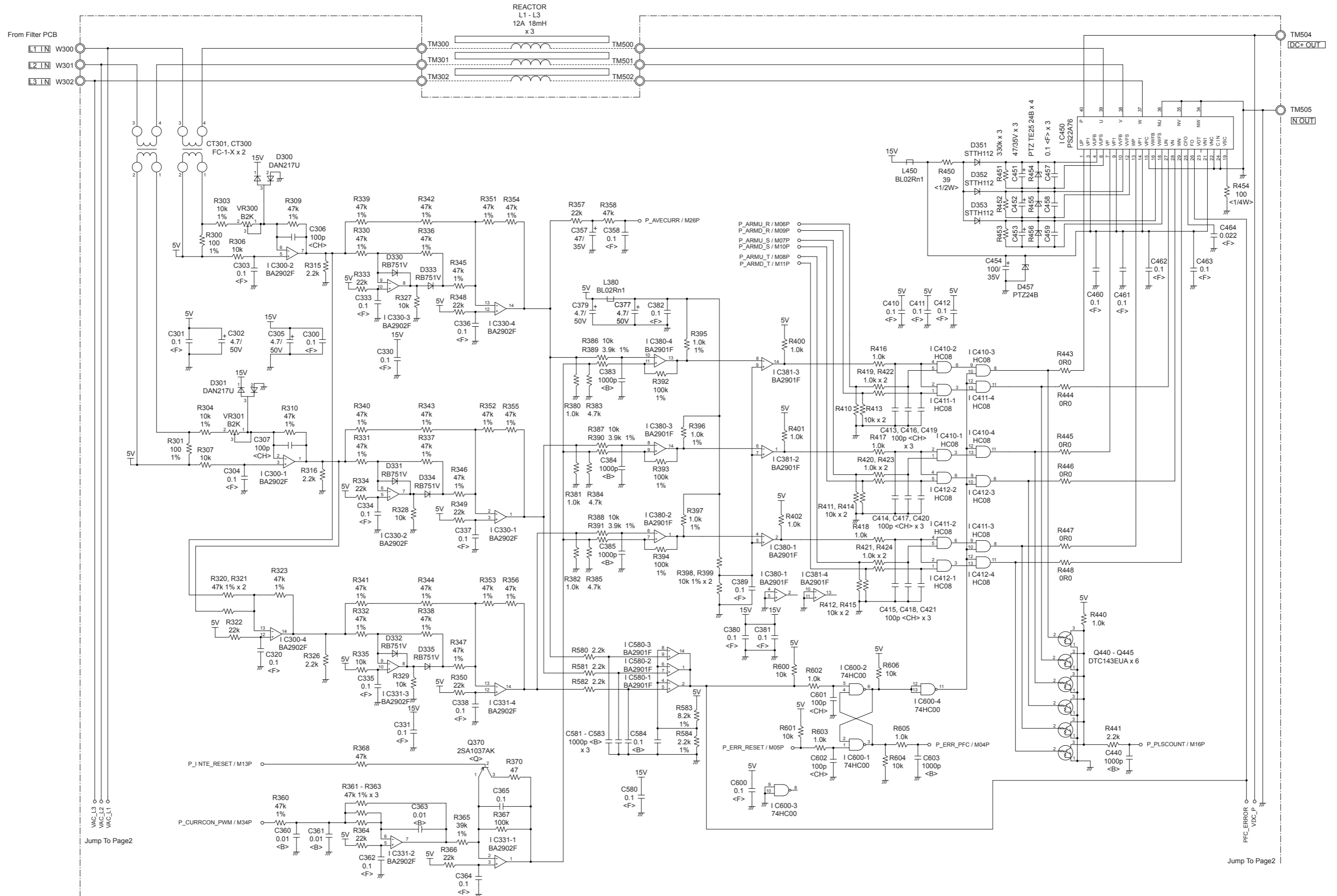

Jump To Page2

Jump To Page2

OUTDOOR UNIT  
ACTIVE FILTER PCB - 2  
K11BZ-1100HUE-AF0

Jump To Page1

Jump To Page1

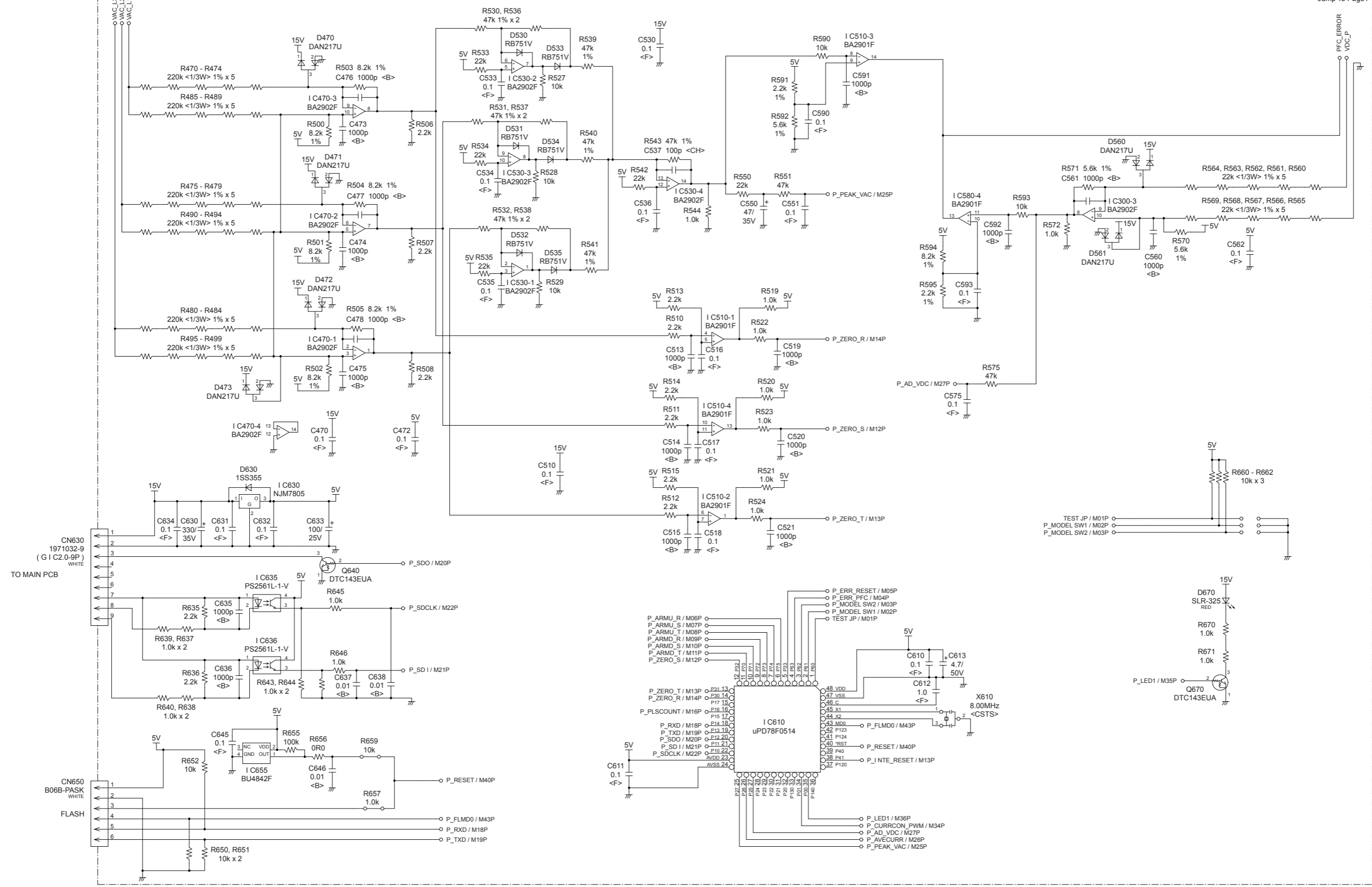

# OUTDOOR UNIT FILTER PCB K07AQ-0700HUE-FLO

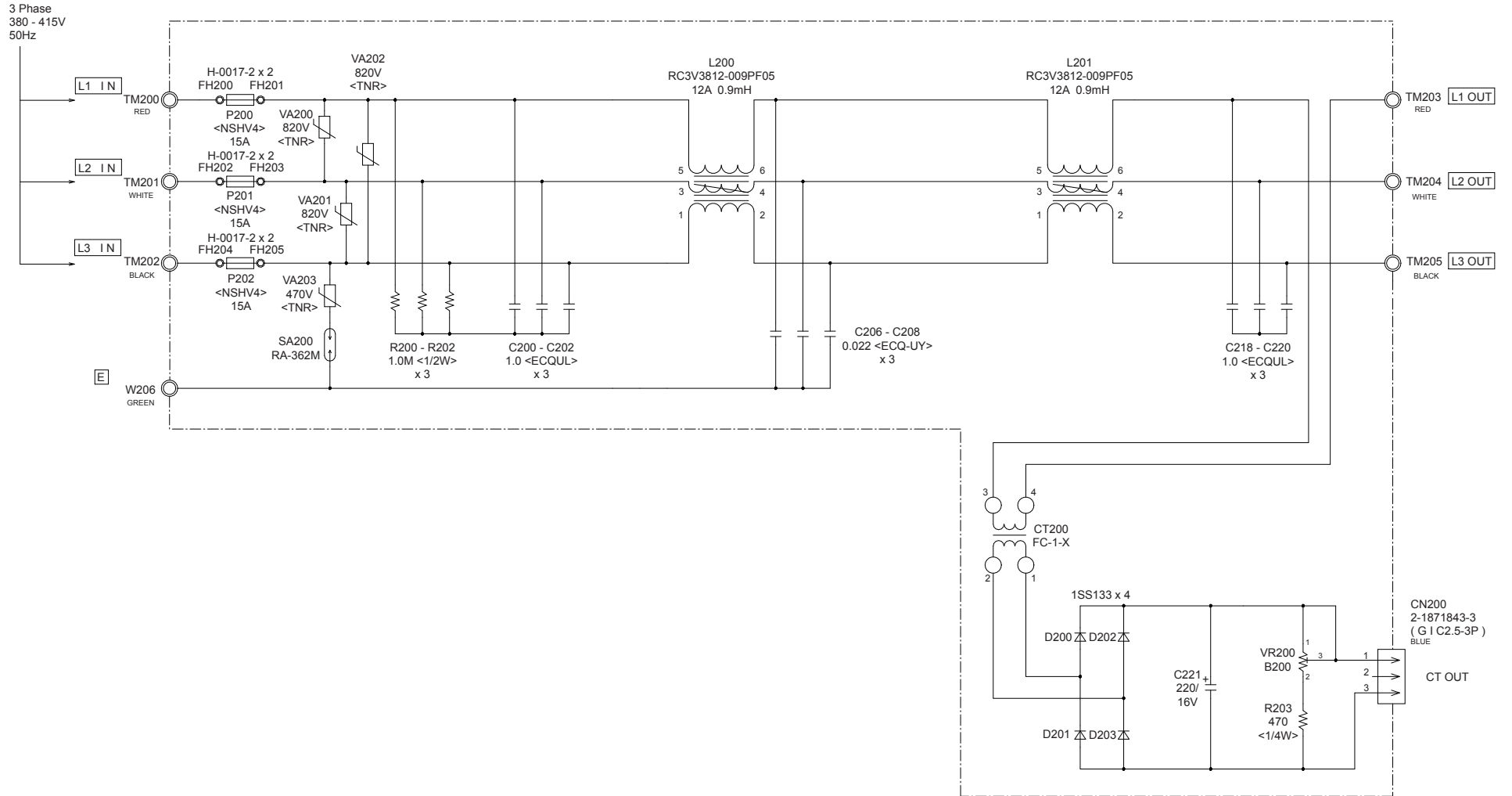



OUTDOOR UNIT  
CAPACITOR PCB  
K07AP-0700HUE-P0

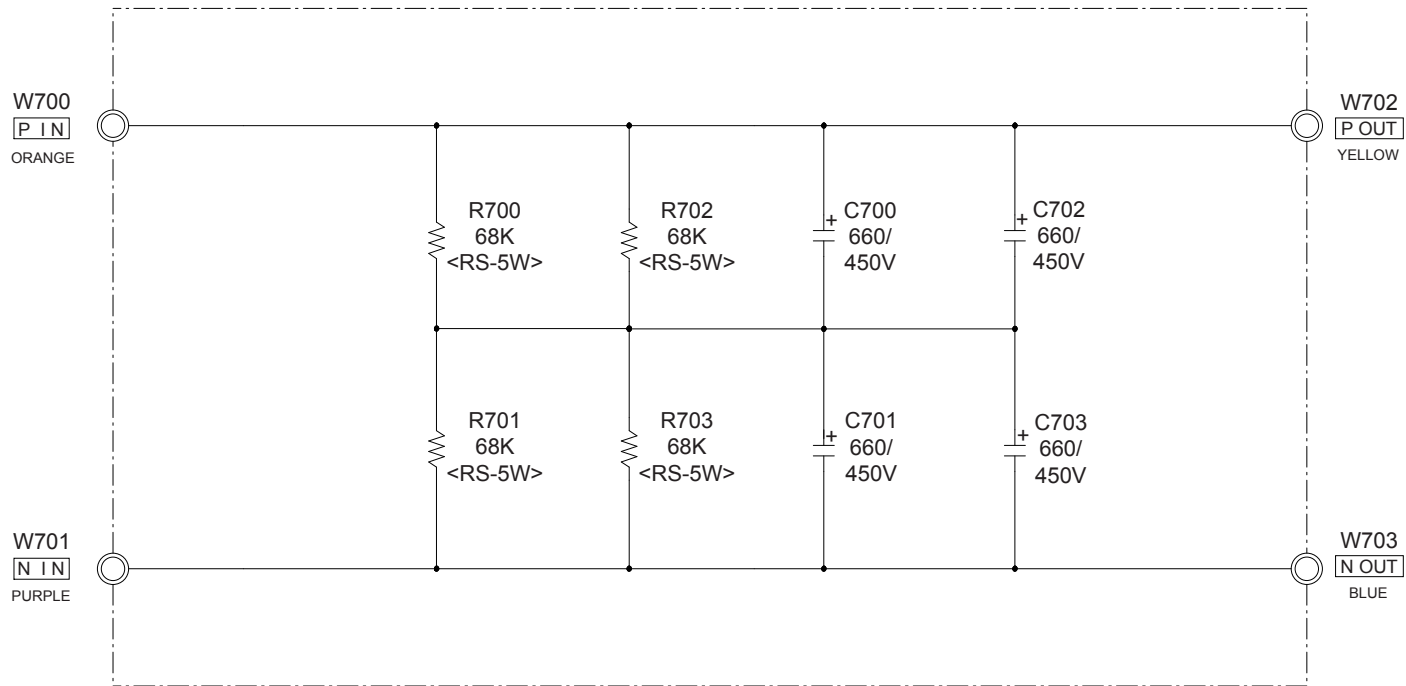

# ERROR DETECTION

## INDOOR UNIT and WIRED REMOTE CONTROL

If you use a wireless remote control, the lamp on the photo detector unit will output error codes by way of blinking patterns.

If you use a wired type remote control, error codes will appear on the remote control display. See the lamp blinking patterns and error codes in the table. An error display is displayed only during running.

### Indoor unit display

Troubleshooting at the display is possible either on the wired or wireless remote control.

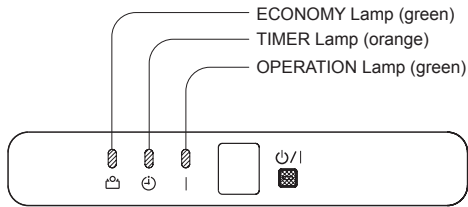

### Remote control

This is possible only on a wired remote control. If an error occurs, the following display will be shown. ("Er" will appear in the set room temperature display.)

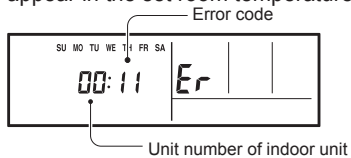

EX. Self-diagnosis

● : 0.5s on / 0.5s off

◇ : 0.1s on / 0.1s off

( ) : Number of flashing

Indoor unit			Wired remote control	Description
OPERATION lamp (green)	TIMER lamp (orange)	ECONOMY lamp (green)		
● (1)	● (1)	◇	11	Serial communication error
● (1)	● (2)	◇	12	Wired remote control communication error
● (1)	● (5)	◇	15	Check run unfinished
● (2)	● (1)	◇	21	R.C. address or Refrigerant circuit address setting error [Simultaneous Multi]
● (2)	● (2)	◇	22	Indoor unit capacity error
● (2)	● (3)	◇	23	Combination error
● (2)	● (4)	◇	24	• Connection R.C. address error (indoor secondary unit) [Simultaneous Multi] • Connection R.C. address error (indoor unit or branch unit) [Flexible Multi]
● (2)	● (7)	◇	27	Primary unit, secondary unit set-up error [Simultaneous Multi]
● (3)	● (1)	◇	31	Power supply interruption error
● (3)	● (2)	◇	32	Indoor unit PCB model information error
● (3)	● (5)	◇	35	Manual auto switch error
● (4)	● (1)	◇	41	Room temp. sensor error
● (4)	● (2)	◇	42	Indoor unit Heat Ex. Middle temp. sensor error
● (5)	● (1)	◇	51	Indoor unit fan motor error
● (5)	● (3)	◇	53	Drain pump error
● (5)	● (7)	◇	57	Damper error
● (5)	● (15)	◇	5U	Indoor unit error
● (6)	● (2)	◇	62	Outdoor unit main PCB model information error or communication error
● (6)	● (3)	◇	63	Inverter error
● (6)	● (4)	◇	64	Active filter error, PFC circuit error
● (6)	● (5)	◇	65	Trip terminal L error
● (6)	● (10)	◇	6A	Display PCB microcomputers communication error

Indoor unit			Wired remote control	Description
OPERATION lamp (green)	TIMER lamp (orange)	ECONOMY lamp (green)		
● (7)	● (1)	◇	71	Discharge temp. sensor error
● (7)	● (2)	◇	72	Compressor temp. sensor error
● (7)	● (3)	◇	73	Outdoor unit Heat Ex. liquid temp. sensor error
● (7)	● (4)	◇	74	Outdoor temp. sensor error
● (7)	● (5)	◇	75	Suction Gas temp. sensor error
● (7)	● (6)	◇	76	• 2-way valve temp. sensor error • 3-way valve temp. sensor error
● (7)	● (7)	◇	77	Heat sink temp. sensor error
● (8)	● (2)	◇	82	• Sub-cool Heat Ex. gas inlet temp. sensor error • Sub-cool Heat Ex. gas outlet temp. sensor error
● (8)	● (3)	◇	83	Liquid pipe temp. sensor error
● (8)	● (4)	◇	84	Current sensor error
● (8)	● (6)	◇	86	• Discharge pressure sensor error • Suction pressure sensor error • High pressure switch error
● (9)	● (4)	◇	94	Trip detection
● (9)	● (5)	◇	95	Compressor rotor position detection error (permanent stop)
● (9)	● (7)	◇	97	Outdoor unit fan motor 1 error
● (9)	● (8)	◇	98	Outdoor unit fan motor 2 error
● (9)	● (9)	◇	99	4-way valve error
● (9)	● (10)	◇	9A	Coil (expansion valve) error
● (10)	● (1)	◇	A1	Discharge temp. error
● (10)	● (3)	◇	A3	Compressor temp. error
● (10)	● (4)	◇	A4	High pressure error
● (10)	● (5)	◇	A5	Low pressure error
● (13)	● (2)	◇	J2	Branch boxes error [Flexible Multi]

# OUTDOOR UNIT

## TEST RUN

### ⚠ CAUTION

Always turn on the power 6 hours prior to the start of the operation in order to protect the compressor.

## 1. Check items before performing the test run

Make sure to perform the test run.

Before performing the test run, be sure to check the following points.

- (1) Is gas leaking?  
Check connection of each pipe (flare connection part, brazing part).
- (2) Is a breaker installed to the power cable of the outdoor unit ?
- (3) Has each cable been securely connected to the terminal according to the specifications ?
- (4) Are the 3-way valves (gas pipes and liquid pipes) of the outdoor units open?
- (5) Has the power been supplied to the unit for at least 6 hours ?
- (6) Has the necessary local setting been done ?
- (7) Check insulation resistance of 1 MΩ or more using a 500V mega tester.

If no problems are found with the above items, perform the test run according to "Test run method".

If any problems are found, immediately resolve the problem and re-check the items.

## 2. Test run method

### ⚠ CAUTION

If the test run is performed for 1 outdoor unit in a group control system installation, the test run will also be performed for the other units. Therefore, make sure that all of the units have been installed before starting a test run.  
(Group control system installation described in "SPECIAL INSTALLATION METHODS" in the installation manual of the indoor unit.)

Operate [ENTER] (TEST RUN) switch on the display board by the following procedure.

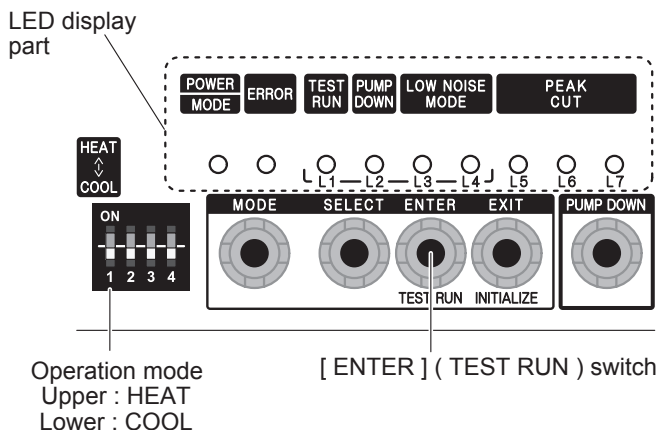

## 2.1. Operating procedures for the test run

- (1) Check the 3-way valves (both at the liquid side and gas side) are opened.
- (2) Set the operation mode to "COOL" or "HEAT".

POWER MODE	ERROR	TEST RUN (L1)	PUMP DOWN (L2)	LOW NOISE (L3) (L4)		PEAK CUT (L5) (L6) (L7)		
●	○	○	○	○	○	○	○	○

In the first test run, be sure to set the operation mode to "COOL".

The operation mode cannot be switched between "COOL" and "HEAT" during the test run. To switch the operation mode between "COOL" and "HEAT", stop the test run, switch the operation mode, and then start the test run again.

- (3) Press [ENTER] (TEST RUN) switch for more than 3 seconds.

POWER MODE	ERROR	TEST RUN (L1)	PUMP DOWN (L2)	LOW NOISE (L3) (L4)		PEAK CUT (L5) (L6) (L7)		
●	○	●	○	○	○	○	○	○

"TEST RUN" LED will light on.

If the compressor is operating at starting the test run, the compressor will stop and, after a while, the test run will start.

Either of the above "LOW NOISE" or "PEAK CUT" will light on during the test run if local setting function is selected.

- (4) Confirm operating status.
- (5) Press [ENTER] (TEST RUN) switch again.

POWER MODE	ERROR	TEST RUN (L1)	PUMP DOWN (L2)	LOW NOISE (L3) (L4)		PEAK CUT (L5) (L6) (L7)		
●	○	○	○	○	○	○	○	○

"TEST RUN" LED lights off, and TEST RUN stops.

Test run will finish after about 60 minutes automatically. At the same time, "TEST RUN" LED will light off.

Test run may be stopped before operating for 60 minutes if an error occurs after a starting test run.

# OUTDOOR UNIT ERROR CODE DISPLAY

Display when an error occurs

POWER MODE	ERROR	TEST RUN (L1)	PUMP DOWN (L2)	LOW NOISE (L3) (L4)		PEAK CUT (L5) (L6) (L7)		
●	Blinks (Hi-speed)	○	○	○	○	○	○	○

Check that the ERROR LED blinks,  
and then short-press the [ENTER] switch once.  
The number of blinks of the LED indicates the type of error.

Display mode ● : ON  
○ : OFF  
◆ : Blink (0.5s ON / 0.5s OFF)  
( ) : Number of flashing

## Error code check table

POWER MODE	ERROR	TEST RUN (L1)	PUMP DOWN (L2)	LOW NOISE (L3) (L4)		PEAK CUT (L5) (L6) (L7)			Description
◆(2)	●	◆(1)	◆(1)	○	○	○	●	●	Serial forward transmission error immediately after operation
◆(2)	●	◆(1)	◆(1)	○	○	●	○	○	Serial forward transmission error during operation
◆(2)	●	◆(2)	◆(2)	○	○	○	○	●	Indoor unit capacity error
◆(2)	●	◆(5)	◆(15)	○	○	○	○	●	Indoor unit error
◆(2)	●	◆(6)	◆(1)	○	○	○	○	●	Over voltage
◆(2)	●	◆(6)	◆(1)	○	○	○	●	●	Power supply frequency error
◆(2)	●	◆(6)	◆(2)	○	○	○	○	●	Outdoor unit PCB model information error
◆(2)	●	◆(6)	◆(2)	○	○	●	●	○	Inverter communication error
◆(2)	●	◆(6)	◆(2)	○	○	●	●	●	PFC communication error
◆(2)	●	◆(6)	◆(3)	○	○	○	○	●	Inverter error
◆(2)	●	◆(6)	◆(4)	○	○	●	●	●	PFC AD detection error
◆(2)	●	◆(6)	◆(4)	○	●	○	○	○	PFC hardware error
◆(2)	●	◆(6)	◆(5)	○	○	○	●	●	IPM error (Trip terminal L error)
◆(2)	●	◆(6)	◆(8)	○	○	○	●	○	Rush current limiting resistor temp rise protection
◆(2)	●	◆(7)	◆(1)	○	○	○	○	●	Discharge temp. sensor error
◆(2)	●	◆(7)	◆(2)	○	○	○	○	●	Compressor temp. sensor error
◆(2)	●	◆(7)	◆(3)	○	○	○	●	○	Heat Ex. middle temp. sensor error
◆(2)	●	◆(7)	◆(3)	○	○	○	●	●	Outdoor unit Heat Ex. liquid temp. sensor error
◆(2)	●	◆(7)	◆(4)	○	○	○	○	●	Outdoor temp. sensor error
◆(2)	●	◆(7)	◆(7)	○	○	○	○	●	Heat sink temp. sensor error
◆(2)	●	◆(7)	◆(7)	○	○	○	●	○	PFC heat sink temp. sensor error
◆(2)	●	◆(8)	◆(4)	○	○	○	○	●	Current sensor 1 error (stoppage permanently)
◆(2)	●	◆(8)	◆(6)	○	○	●	○	○	High pressure switch 1 error
◆(2)	●	◆(8)	◆(6)	○	○	●	●	○	Pressure sensor error
◆(2)	●	◆(9)	◆(4)	○	○	○	○	●	Trip detection (stoppage permanently)
◆(2)	●	◆(9)	◆(5)	○	○	○	○	●	Compressor motor control error (stoppage permanently)
◆(2)	●	◆(9)	◆(5)	○	○	●	○	●	Compressor motor loss of synchronization (stoppage permanently)
◆(2)	●	◆(9)	◆(7)	○	○	○	●	●	Outdoor unit fan motor 1 error (Duty error)
◆(2)	●	◆(9)	◆(8)	○	○	○	●	●	Outdoor unit fan motor 2 error (Duty error)
◆(2)	●	◆(9)	◆(9)	○	○	○	○	●	4-way valve error
◆(2)	●	◆(10)	◆(1)	○	○	○	○	●	Discharge temp. 1 error (stoppage permanently)
◆(2)	●	◆(10)	◆(3)	○	○	○	○	●	Compressor 1 temp. error (stoppage permanently)
◆(2)	●	◆(10)	◆(5)	○	○	○	○	●	Low pressure error

# OUTDOOR UNIT

## PUMP DOWN (Refrigerant collecting operation)

Perform the following procedures to collect the refrigerant when moving the indoor unit or outdoor unit

**WARNING**  
Never touch electrical components such as the terminal blocks or reactor except the switch on the display board. It may cause a serious accident such as electric shock.

**CAUTION**  
Perform the pump down operation before disconnecting any refrigerant pipe or electric cable.

Collect refrigerant from the service port or the 3-way valve if pump down cannot be performed.

In case of a group control system installation, do not turn the power off pump down is completed in all outdoor units.  
(Group control system installation described in "SPECIAL INSTALLATION METHODS" in the installation manual of the indoor unit.)

Operate [PUMP DOWN] switch on the display board in the manner described below.

LED display part

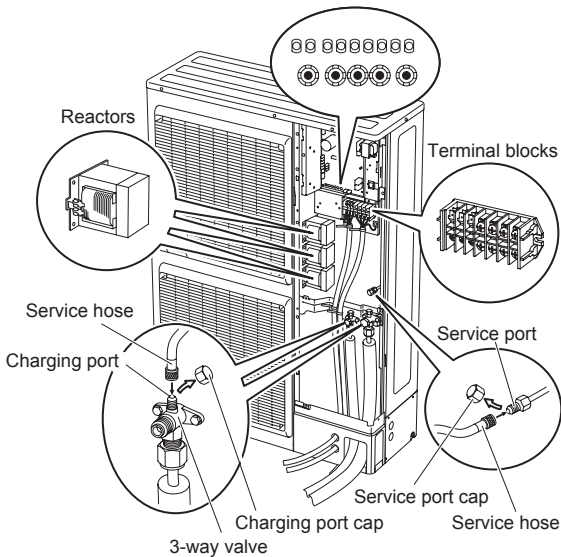
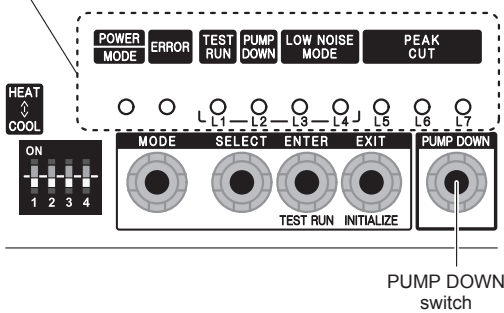

### 1. Preparation for pump down

Confirm that the power is off, and then open the service panel.

### 2. Pump down procedure

- (1) Check the 3-way valves (both at the liquid side and gas side) are opened.
- (2) Turn the power on.

POWER	ERROR	TEST RUN (L1)	PUMP DOWN (L2)	LOW NOISE (L3)	(L4)	PEAK CUT (L5) (L6) (L7)		
●	○	○	○	○	○	○	○	○

- (3) Press [PUMP DOWN] switch for 3 seconds or more after 3 minutes after power on.

POWER	ERROR	TEST RUN (L1)	PUMP DOWN (L2)	LOW NOISE (L3)	(L4)	PEAK CUT (L5) (L6) (L7)		
●	○	○	●	○	○	●	●	●

LED display lights on as shown in the above figure, and the fans and the compressor start operating.

If the [PUMP DOWN] switch is pressed while the compressor is operating, the compressor will stop, then start again in about 3 minutes.

- (4) LED display will change as shown below about 3 minutes after the compressor starts. Fully close the 3-way valve on the liquid pipe side at this stage.

POWER	ERROR	TEST RUN (L1)	PUMP DOWN (L2)	LOW NOISE (L3)	(L4)	PEAK CUT (L5) (L6) (L7)		
●	○	○	●	○	○	○	●	●

If the valve on the liquid pipe side is not closed, the pump down cannot be performed.

- (5) When LED display changes as shown in the below figure, close the 3-way valve on the gas pipe side tightly.

POWER	ERROR	TEST RUN (L1)	PUMP DOWN (L2)	LOW NOISE (L3)	(L4)	PEAK CUT (L5) (L6) (L7)		
●	○	○	●	○	○	○	○	●

If the valve on the gas pipe side is not closed, refrigerant may flow into the piping after the compressor stops

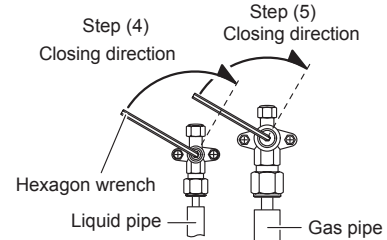

- (6) LED display changes after 1 minute as shown in the figure below

POWER	ERROR	TEST RUN (L1)	PUMP DOWN (L2)	LOW NOISE (L3)	(L4)	PEAK CUT (L5) (L6) (L7)		
●	○	○	●	○	○	○	○	○

Fans and compressor stop automatically.

If the pump down is successfully completed (the above LED display is shown), the outdoor unit remains stopped until the power is turned off.

- (7) Turn the power off.

POWER	ERROR	TEST RUN (L1)	PUMP DOWN (L2)	LOW NOISE (L3)	(L4)	PEAK CUT (L5) (L6) (L7)		
○	○	○	○	○	○	○	○	○

PUMP DOWN is completed.

(Note)

To stop pump down, press the [PUMP DOWN] switch again.

To start the pump down again after the compressor is automatically stopped due to an error, turn the power off and open the 3-way valves. Wait 3 minutes, turn the power on and start the pump down again.

When starting the operation after completion of the pump down, turn the power off, and then open the 3-way valves. Wait 3 minutes, turn the power on and perform a test run in the "COOL" operation mode.

# PARTS

## INDOOR UNIT

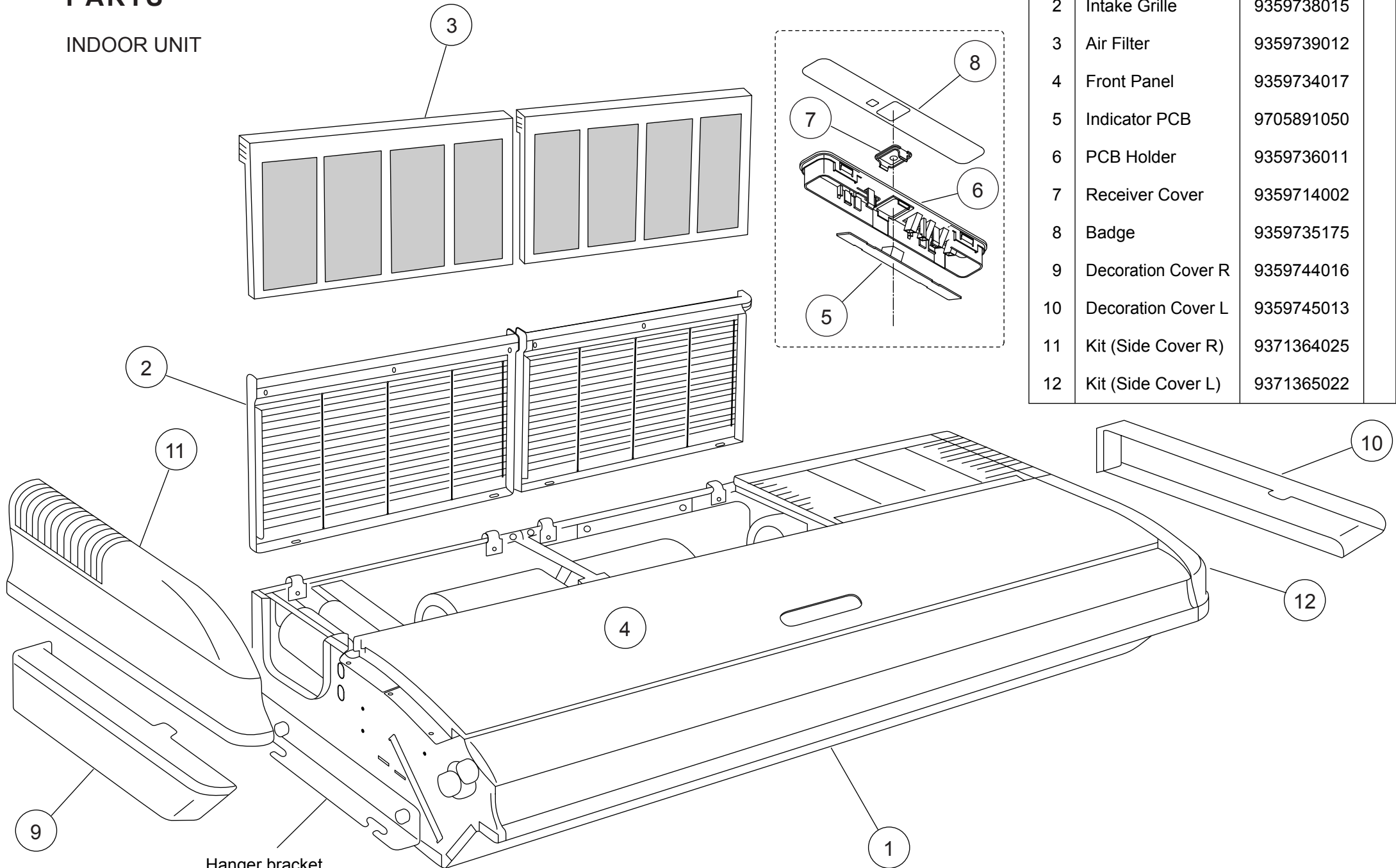

Ref.	Description	Part number
1	Top Cover	9359737018
2	Intake Grille	9359738015
3	Air Filter	9359739012
4	Front Panel	9359734017
5	Indicator PCB	9705891050
6	PCB Holder	9359736011
7	Receiver Cover	9359714002
8	Badge	9359735175
9	Decoration Cover R	9359744016
10	Decoration Cover L	9359745013
11	Kit (Side Cover R)	9371364025
12	Kit (Side Cover L)	9371365022

INDOOR UNIT  
Fan motor

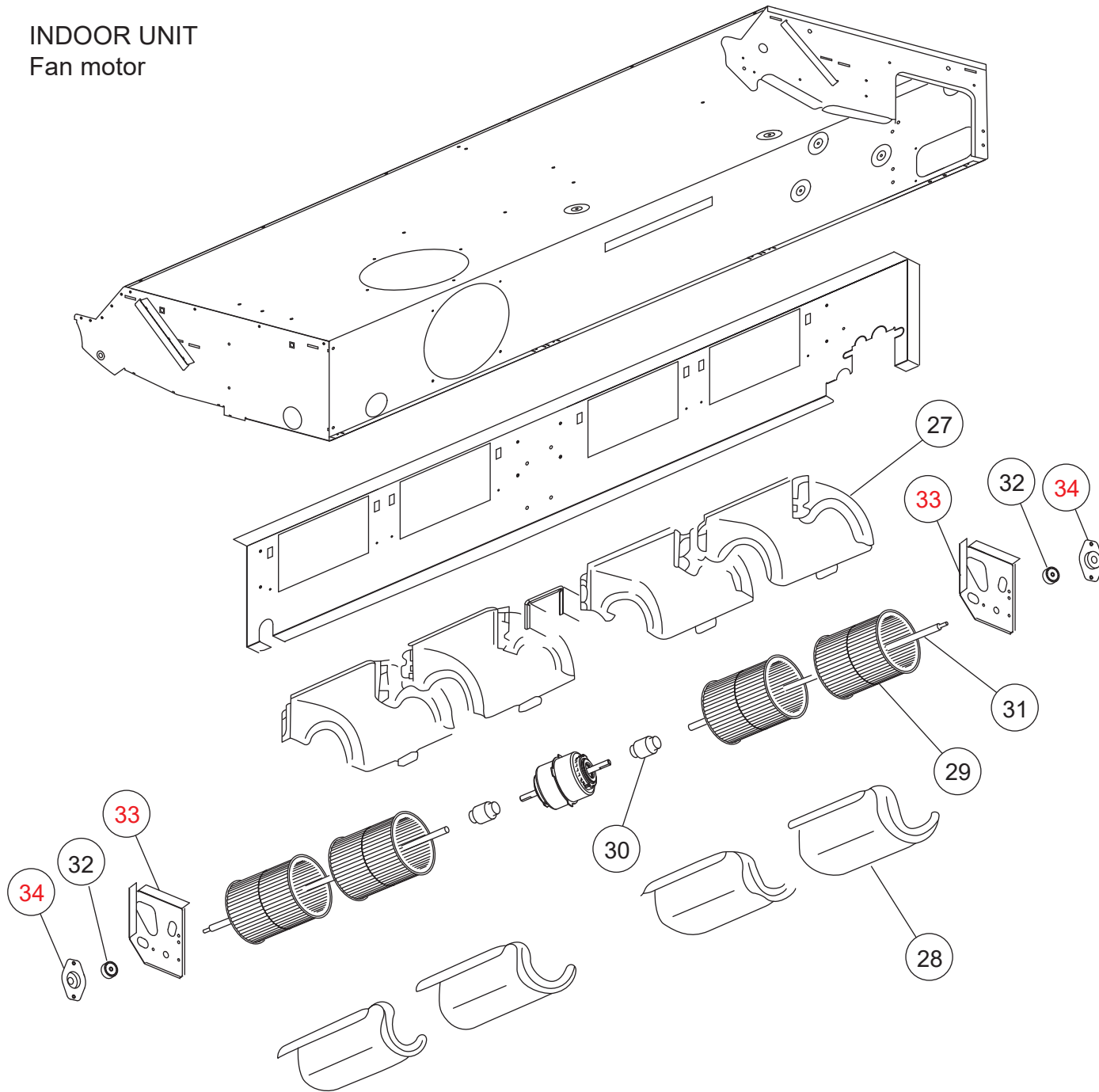

Ref.	Description	Part number
21	Motor Mount	9377999016
22	Motor Band A Assy	9374648016
23	Motor band B	9374648023
24	RFM Motor Band	9378000018
25	Fan Motor Assy	9603286019
26	Rubber (Vibration Proof)	9385102002
27	Casing	9359704003
28	Kit (Cover Casing) Sub Assy	9371367019
29	Sirocco Fan Assy	9359701002
30	Joint Assy	9378038011
31	Shaft	9359707004
32	Bearing B Assy	9357921006
33	Shaft Holder Bracket	9359686002
34	Shaft Holder Fixture	9359687009

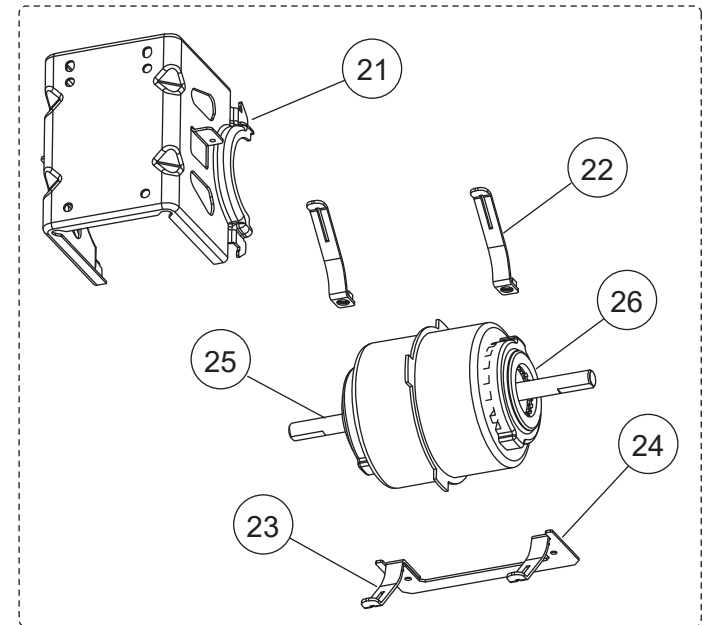

INDOOR UNIT  
Evaporator  
Drain pan  
Flap

Ref.	Description	Part number
41	Kit (Base Sub Assy)	9371360010
42	Panel Left Sub Assy	9360427014
43	Kit (Panel Right Assy)	9371361017
44	Evaporator Sub Assy (36, 45)	9360428264
44	Evaporator Sub Assy (54)	9360428301
45	Drain Pan Sub Assy	9360429032
46	Flap Assy	9359731016
47	Flap Spring	9359730002
48	Sector Gear	9359729006
49	Pinion Gear	9359728009
50	Motor Base	9359727002
51	Step Motor	9900362010
--	Drain Cap	9358746004

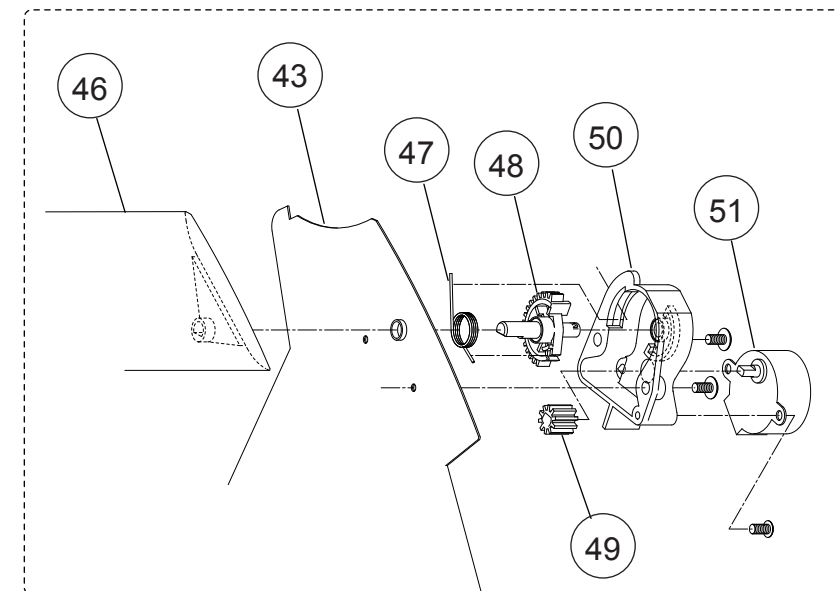
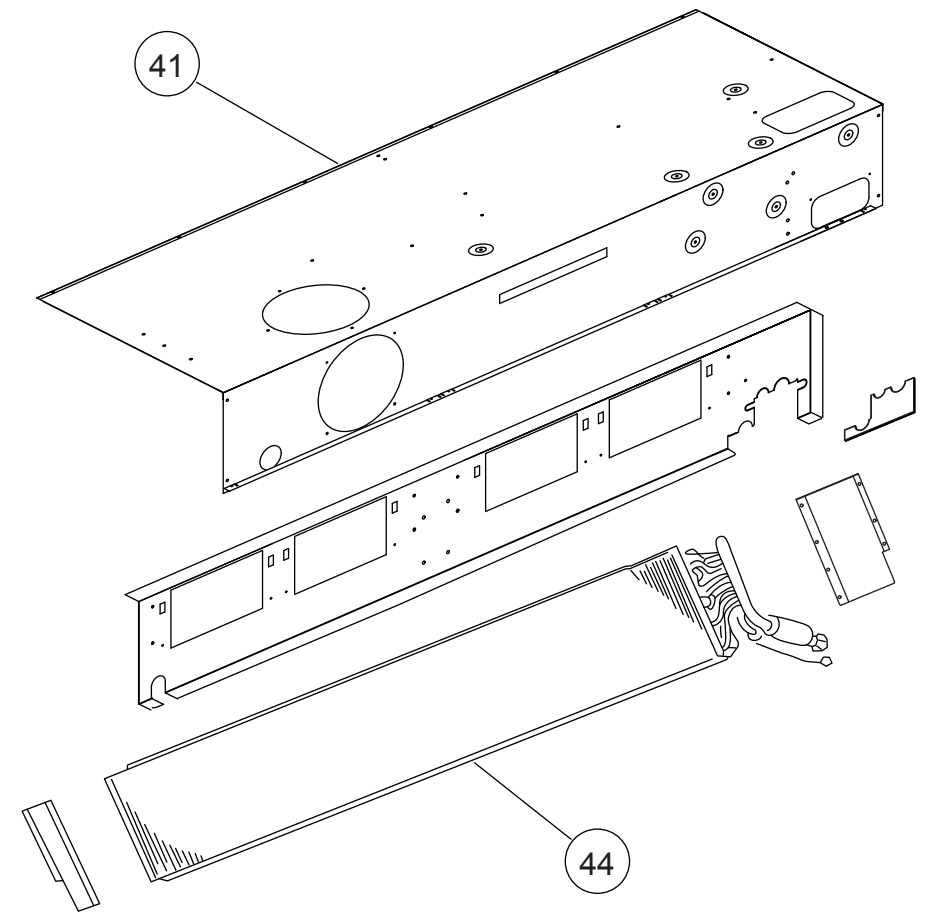
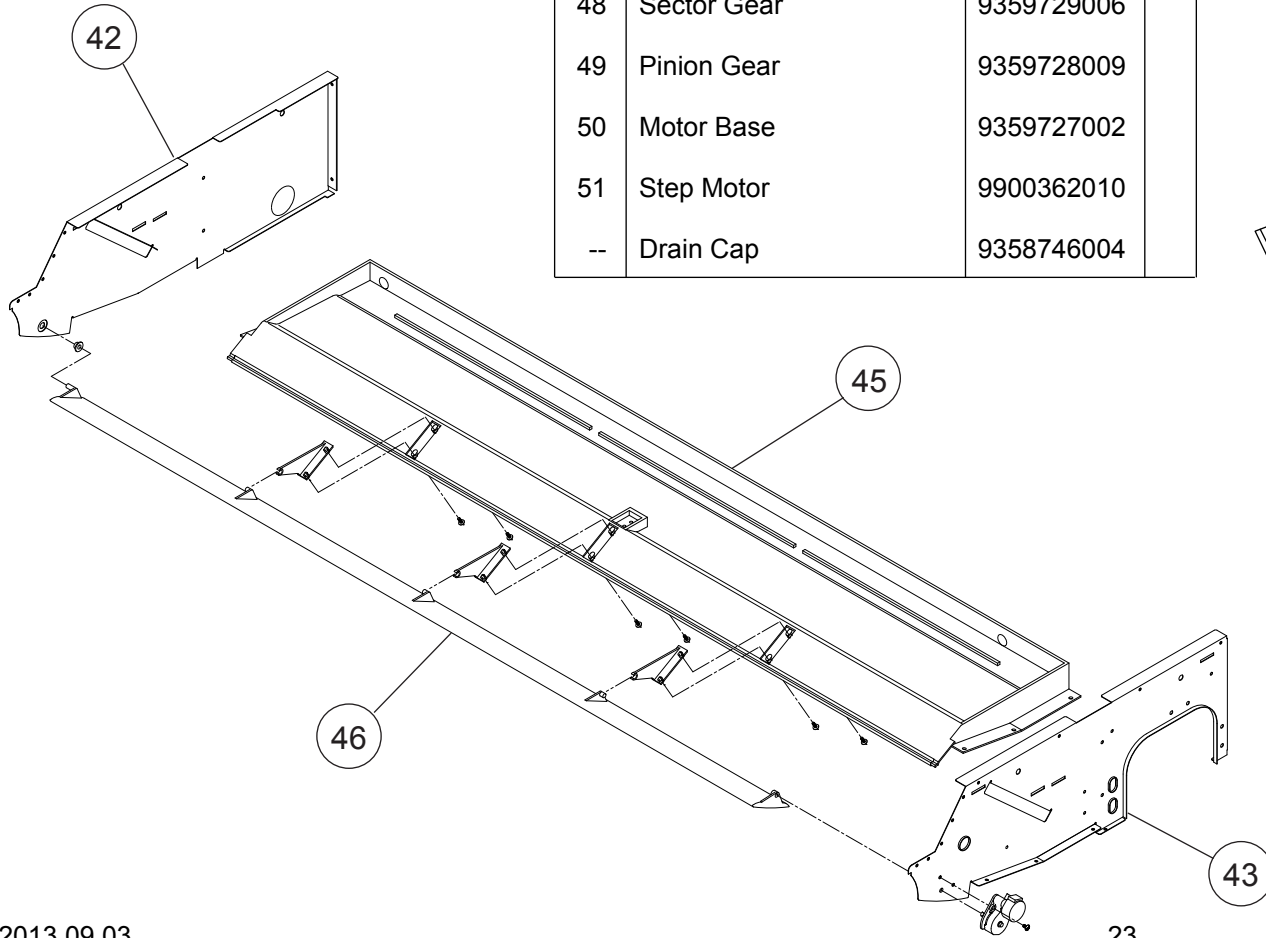



INDOOR UNIT  
Louver Base Sub Assy

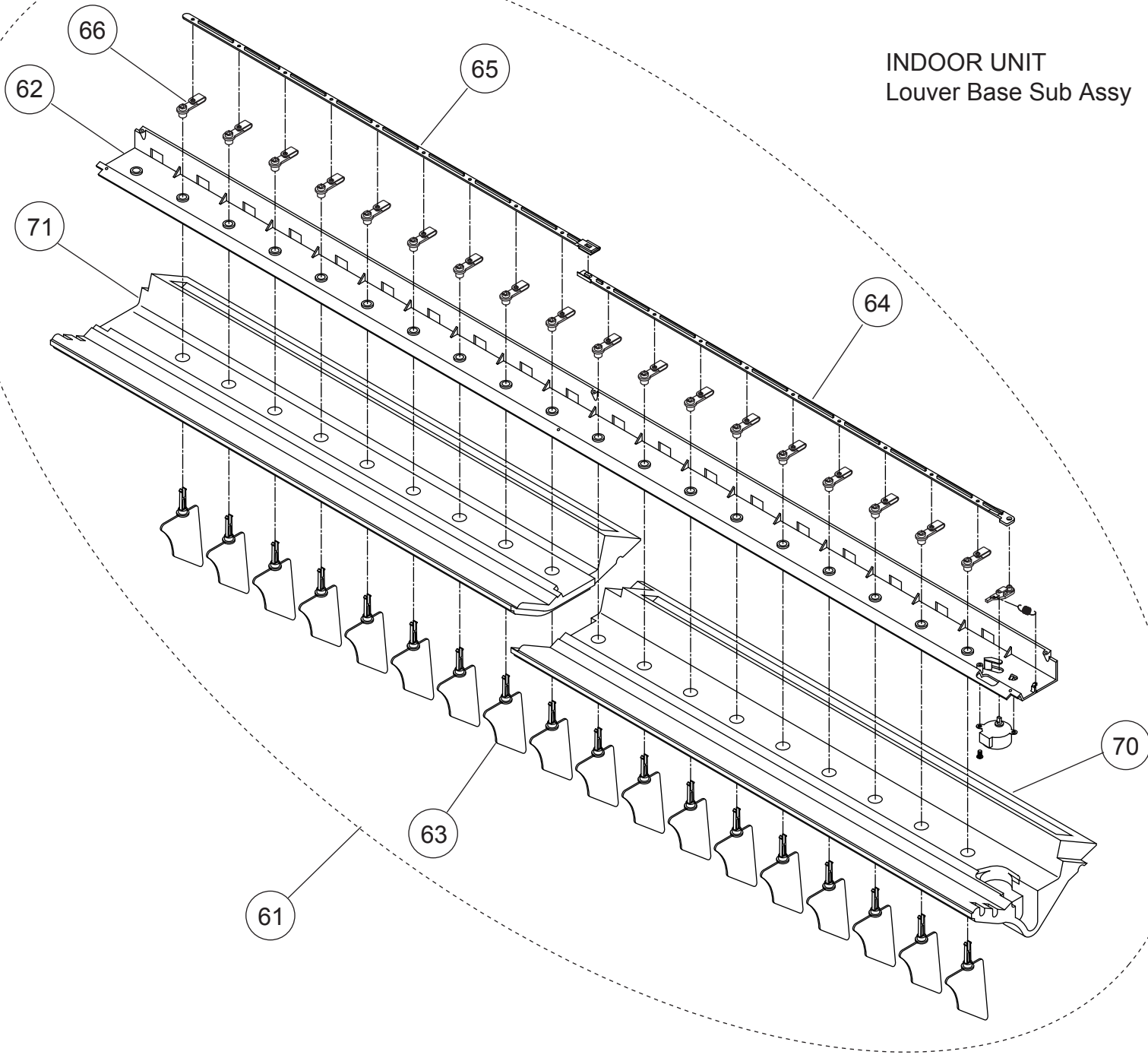

Ref.	Description	Part number
61	Louver Base Sub Assy	9360432049
62	kit (Louver Base)	9371369013
63	Louver	9359719014
64	Motor Rod	9359723004
65	Louver Rod	9359725008
66	Louver Stopper	9359724001
67	Louver Link	9359726005
68	Louver Spring	9359720003
69	Step Motor H	9900297015
70	Louver Insulation R	9359721000
71	Louver Insulation L	9359722007

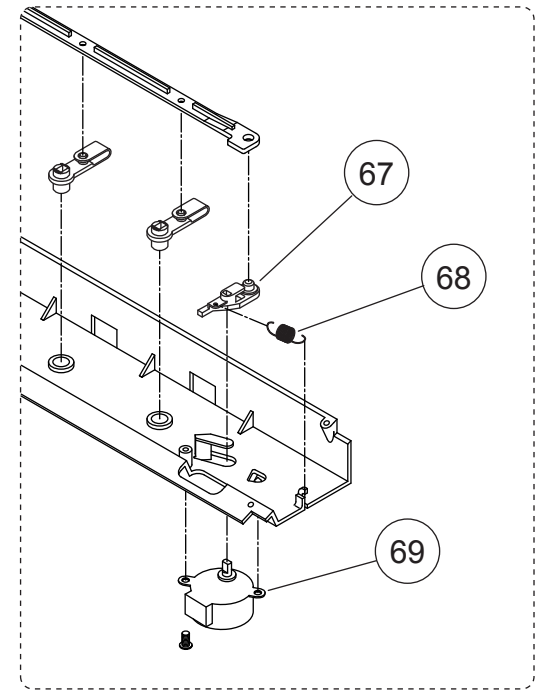

INDOOR UNIT  
Control unit

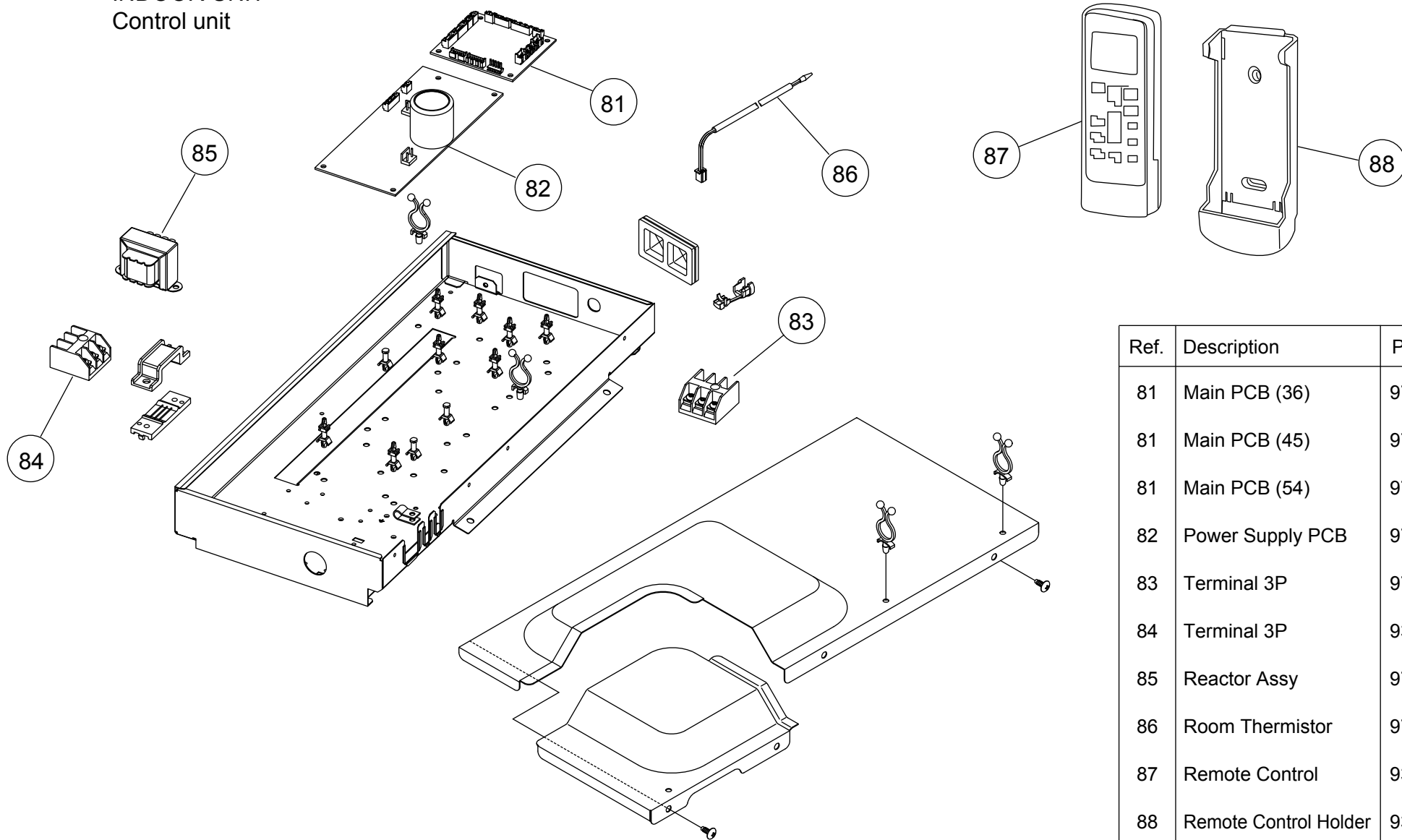

Ref.	Description	Part number
81	Main PCB (36)	9709245385
81	Main PCB (45)	9709245392
81	Main PCB (54)	9709245521
82	Power Supply PCB	9707398342
83	Terminal 3P	9703345012
84	Terminal 3P	9306489045
85	Reactor Assy	9707457018
86	Room Thermistor	9703299025
87	Remote Control	9379219037
88	Remote Control Holder	9305642045
--	Pipe Thermistor	9900022020

# PARTS

## OUTDOOR UNIT

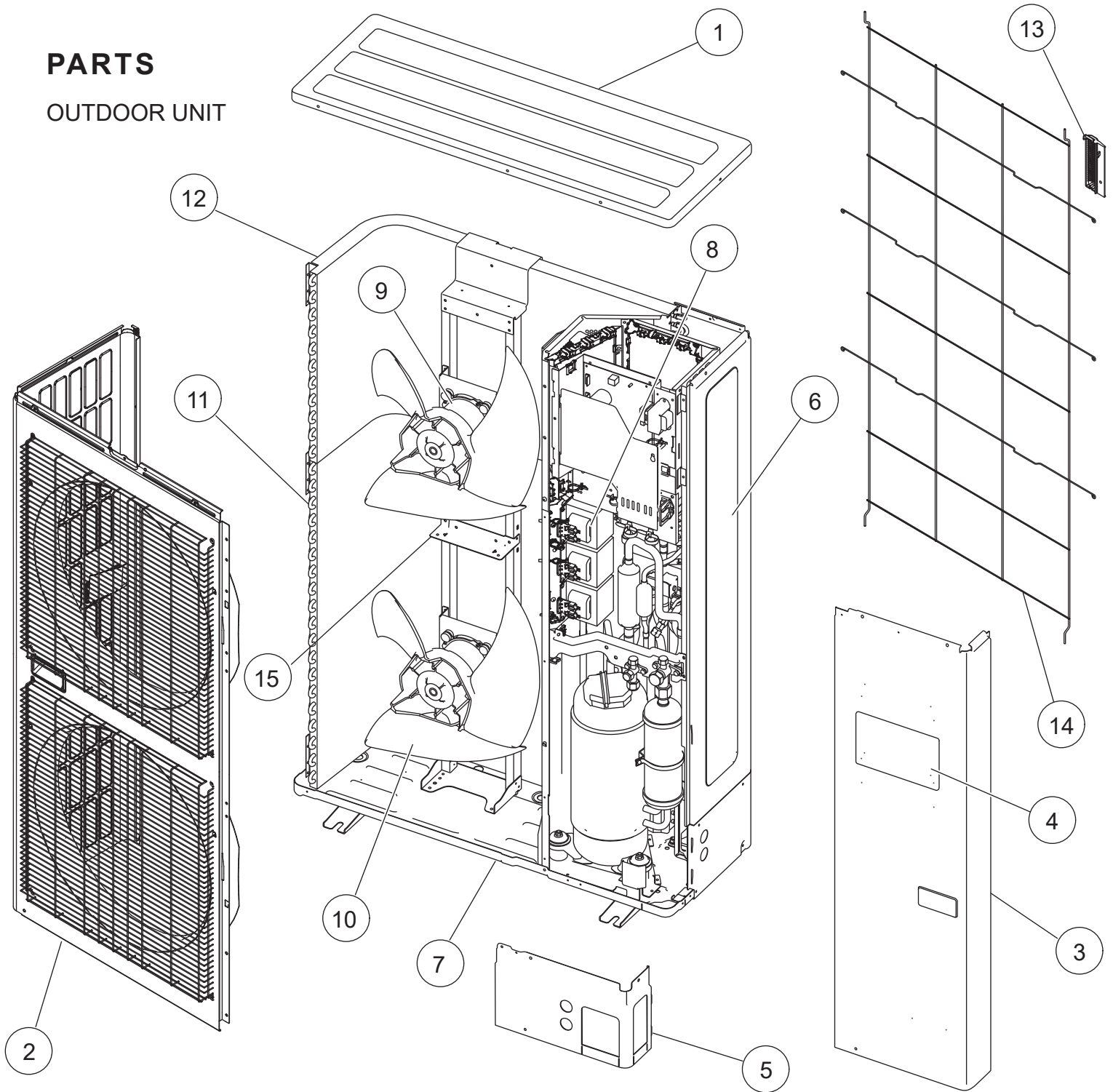

Ref.	Description	Parts number
1	Top Panel Sub Assy	9374417032
2	Front Panel Sub Assy	9374414130
3	Sevice Panel Sub Assy	9374415076
4	Emblem Rear	9351355005
5	Pipe Cover Front	9378861015
6	Right Panel Sub Assy	9374416219
7	Base Assy	9374166220

Ref.	Description	Parts number
8	Reactor Assy	9900641016
9	Motor, DC Brushless	9602843046
10	Propeller Fan Assy	9366378020
11	Condenser A Sub Assy	9374420261
12	Condenser B Sub Assy	9374422081
13	Thermo Holder	9375211011
14	Protective Net	9375381042
15	Motor Bracket Sub Assy	9374418145

# OUTDOOR UNIT

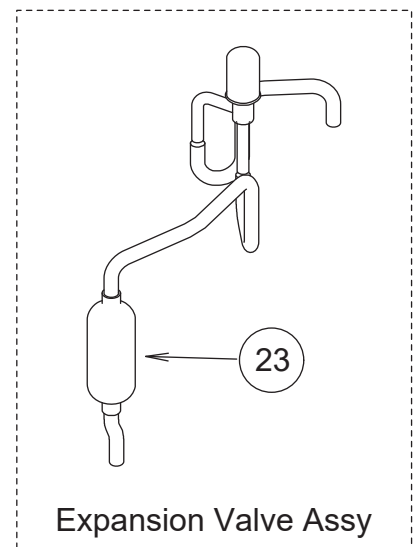
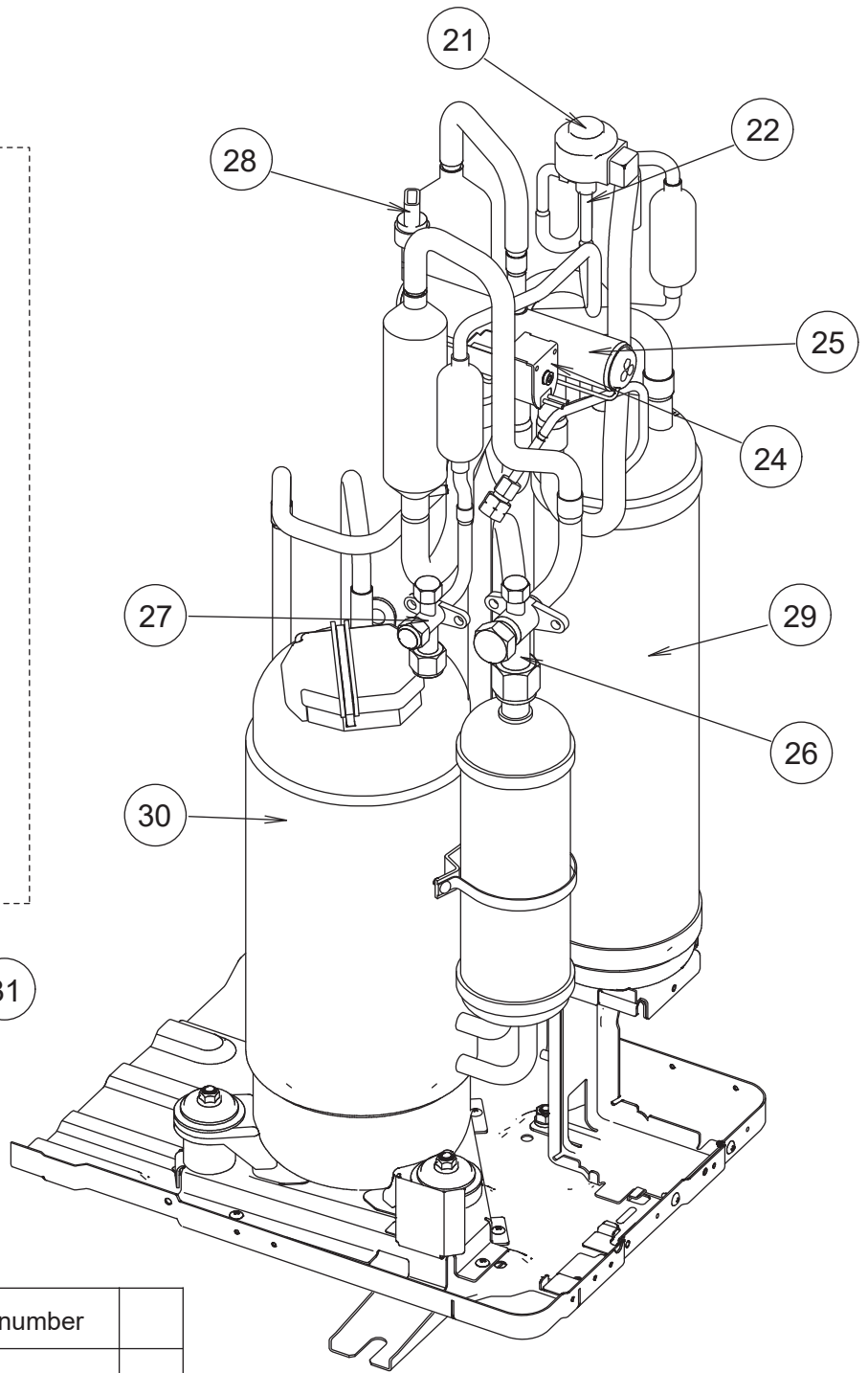
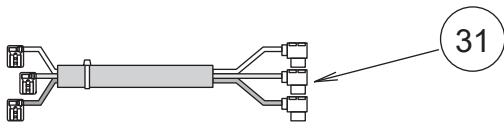
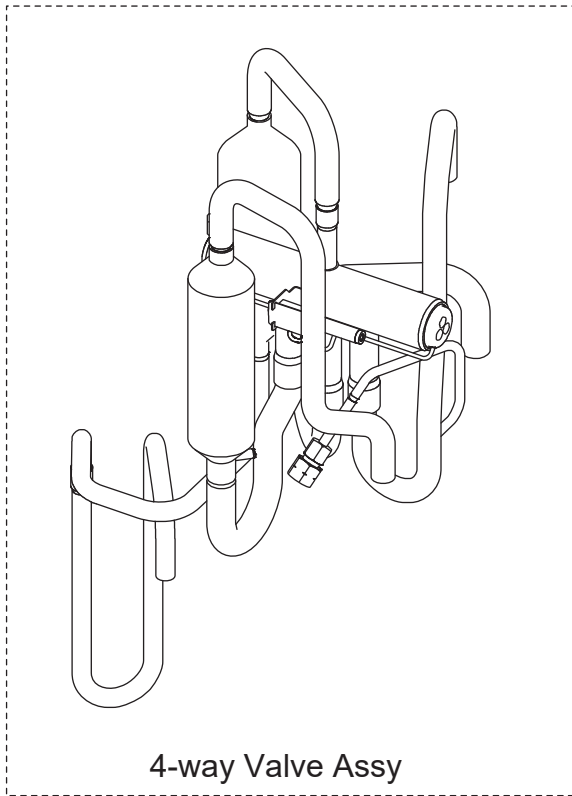

Ref.	Description	Parts number
21	Expansion Valve Coil	9900190057
22	Expansion Valve Assy	9370947182
23	Strainer Assy	9372524039
24	Solenoid	9970113024
25	4-way Valve Assy	9374425273
26	3-way Valve Assy	9379079006
27	3-way Valve Assy	9379077002
28	Sensor	9900505011
29	Accumulator Assy	9375250096
30	Compressor Assy	9383162008
31	Wire w/Terminal for Comp.	9707933055



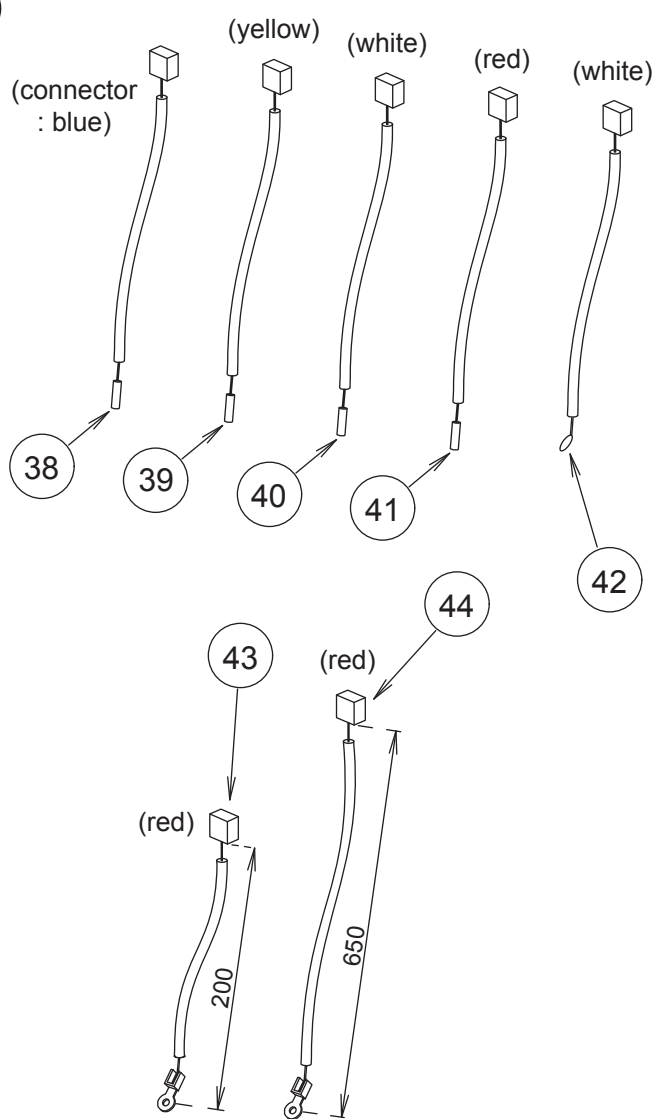
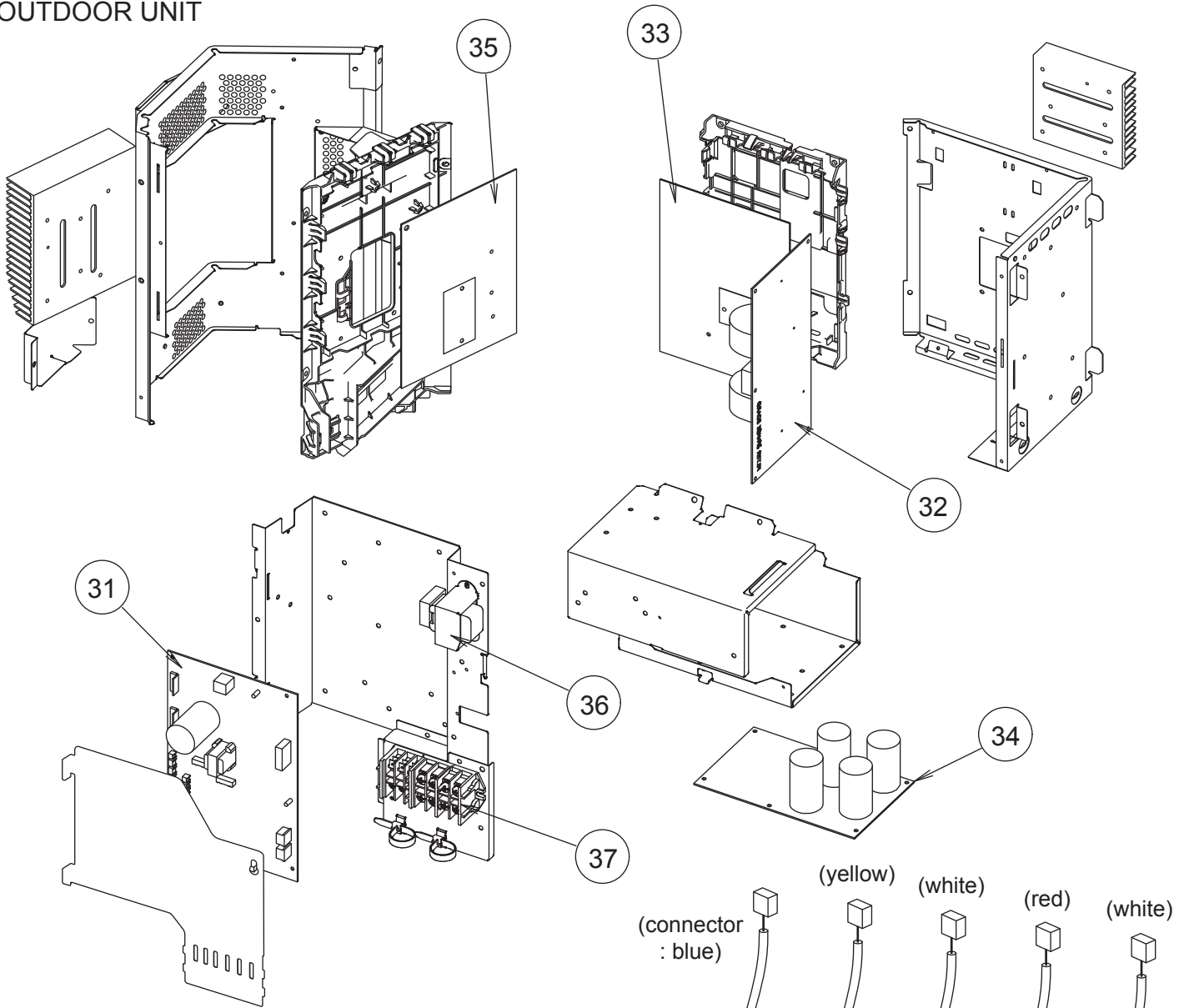





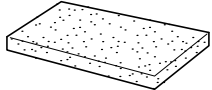

# OUTDOOR UNIT



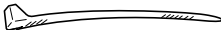

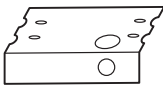
Ref.	Description	Parts number
31	Main PCB (36)	9707627091
31	Main PCB (45)	9707627077
31	Main PCB (54)	9707627084
32	Filter PCB	9707609011
33	Active Filter PCB with grease	9709680438
34	Capacitor PCB	9707608014
35	Transistor PCB with grease	9709680445
36	Reactor Assy	9900481018
37	Terminal	9900428082
38	Compressor Thermistor	9900516000
39	Discharge Thermistor	9900515003
40	Thermistor (Heat Exchanger Mid)	9900513009
41	Thermistor (Heat Exchanger Out)	9900514006
42	Outdoor Thermistor	9900517007
43	Heatsink Thermistor (Inverter)	9900518011
44	Heatsink Thermistor (PFC)	9900518028

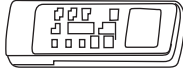
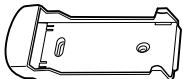
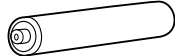
# ACCESSORIES

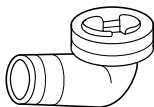
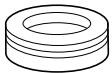

## INDOOR UNIT

Name and Shape	Q'ty	Application	Part number
Drain hose insulation 	1	Adhesive type 70 x 230	9360464002
VT wire 	1	For fixing the drain hose L 280 mm	313806350303
Coupler heat insulator (large) 	2	For indoor side pipe joint (gas pipe)	9378173569
Coupler heat insulator (small) 	1	For indoor side pipe joint (liquid pipe)	9378173521
Cable tie 	Large 4	For fixing the coupler heat insulator	9301501001
	Small 4		312300787605
Special nut A (large flange) 	4	For installing indoor unit	313005446653
Special nut B (small flange) 	4	For installing indoor unit	313005446759
Installation template 	1	For positioning the indoor unit	9360022004
Auxiliary pipe assembly 	1	For connecting the piping	9374714025
Remote control 	1	For air conditioner operation	9379219037
Remote control holder 	1	For installing remote control on the wall	9305642045
Battery 	2	For remote control	0600185541
Tapping screw 	2	For mounting the remote control holder	0700019036

## OUTDOOR UNIT

Name and Shape	Q'ty	Application	Part number
Drain pipe 	1	For drain piping work	9303029015
Drain cap 	2	For drain piping work	313166024302
One-touch bush 	2	For drain piping work	9378779013

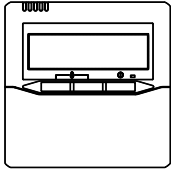
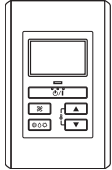
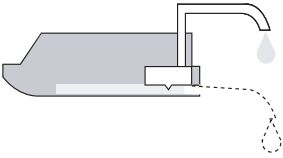
## OPTIONAL PARTS

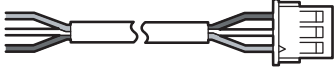
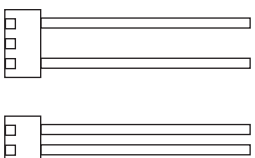
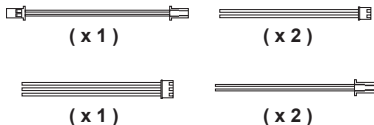
Name and Shape	Model name	Use
Wired remote control 	UTY-RNNYM	Unit control is performed by wired remote control
Simple remote control 	UTY-RSNYM	For air conditioner operation
Drain pump unit 	UTR-DPB24T	
Round flange 	UTD-RF204	To take fresh air
External connect kit INPUT / OUTPUT 	UTY-XWZXZ2	For control input/output port
External connect kit 	UTY-XWZX	For control input/output port
External connect set 	UTD-ECS5A	Use to connect with various peripheral devices and air conditioner PC board. (Set of 6)

1204G4041