

SERVICE MANUAL



Indoor unit	Outdoor unit
RD-45FA	RO-45FA
RD-45UA	RO-45UA

CONTENTS

SPECIFICATIONS	1
DIMENSIONS	3
REFRIGERANT SYSTEM DIAGRAM	5
CIRCUIT DIAGRAM	6
INDOOR PCB CIRCUIT DIAGRAM	8
OUTDOOR PCB CIRCUIT DIAGRAM	10
ERROR DISPLAY	11
DISASSEMBLY ILLUSTRATION	12
PARTS LIST	21
STANDARD ACCESSORIES	23

SPECIFICATIONS

TYPE		COOLING	COOLING & HEATING
INDOOR UNIT		RD-45FA	RD-45UA
OUTDOOR UNIT		RO-45FA	RO-45UA
COOLING CAPACITY	(kW)	12.7	12.7
HEATING CAPACITY	(kW)	—	14.3

ELECTRICAL DATA

POWER SOURCE	(V)	400	
FREQUENCY	(Hz)	50	
RUNNING CURRENT	(A)	COOLING	7.70
		HEATING	—
INPUT WATTS	(kW)	COOLING	4.38
		HEATING	—
E.E.R.	(kW /kW)	COOLING	2.90
		HEATING	—
STARTING CURRENT	(A)	67	
MOISTURE REMOVAL	(ℓ/hr)	510	

Note : The above list shows values at the external static pressure of 98Pa (10mm Ag), setting the fan speed high notch.

COMPRESSOR

TYPE	Hermetic type, 2 pole, Single phase, Induction motor, Rotary		
DISCRIMINATION	BN52YEAMT		
REFRIGERANT	R410A	(g)	3,400

FAN SPEED (r.p.m.)	DISCRIMINATION		MFA-45PTAT	
	INDOOR	HIGH	1,280	
		MED	1,200	
		LOW	1,100	
DISCRIMINATION		MFB-30PTT		
OUTDOOR		780		
AIR FLOW (m ³ /h)	INDOOR		1,800	
	OUTDOOR		6,100	
DIMENSIONS H x W x D (mm)	INDOOR		270 x 1,135 x 700	
	OUTDOOR		1,165 x 900 x 330	
WEIGHT GROSS / NET (kg)	INDOOR		52 / 45	
	OUTDOOR		116 / 109	120 / 113
MAX PIPE LENGTH / HEIGHT		(m)	50 / 30	
REMOTE CONTROLLER TYPE		WIRED		

Note : The above list shows values at the external static pressure of 100Pa, setting the fan speed high notch.

TYPE	COOLING	COOLING & HEATING
INDOOR UNIT	RD-45FA	RD-45UA
OUTDOOR UNIT	RO-45FA	RO-45UA

NOISE LEVEL

INDOOR UNIT	HI-SPEED (dB)	44	
	MED-SPEED (dB)	42	
	LO-SPEED (dB)	40	
OUTDOOR UNIT	(dB)	54	COOL 54 / HEAT 56

Note : Static pressure : 100Pa

Duct length : Inlet 1m, Outlet 2m

FULL CHARGE AMOUNT	PIPE LENGTH	20 m (66 ft)	3,400 g (119.9 oz)
		30 m (99 ft)	3,800 g (134.0 oz)
		40 m (132 ft)	4,200 g (148.2 oz)
		50 m (165 ft)	4,600 g (162.3 oz)
ADDITIONAL REFRIGERANT			40 g / m (0.424 oz / ft)

When you dismantle indoor units which are installed,
take care not to make parts fall down, especially motors.

DIMENSIONS

INDOOR UNIT

Models : RD-45FA, RD-45UA

(Unit : mm)

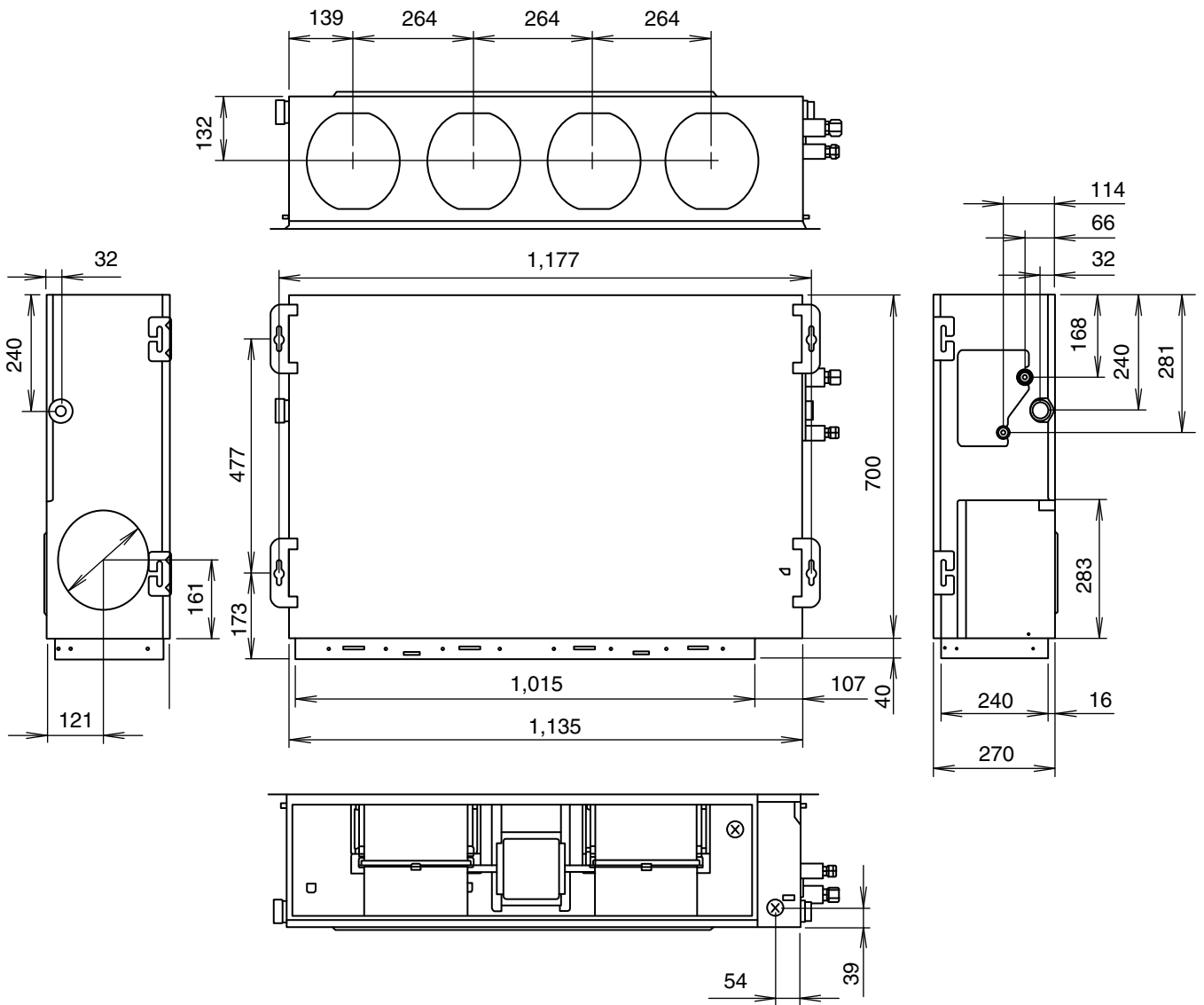

OUTDOOR UNIT

Models : RO-45FA, RO-45UA

(Unit : mm)

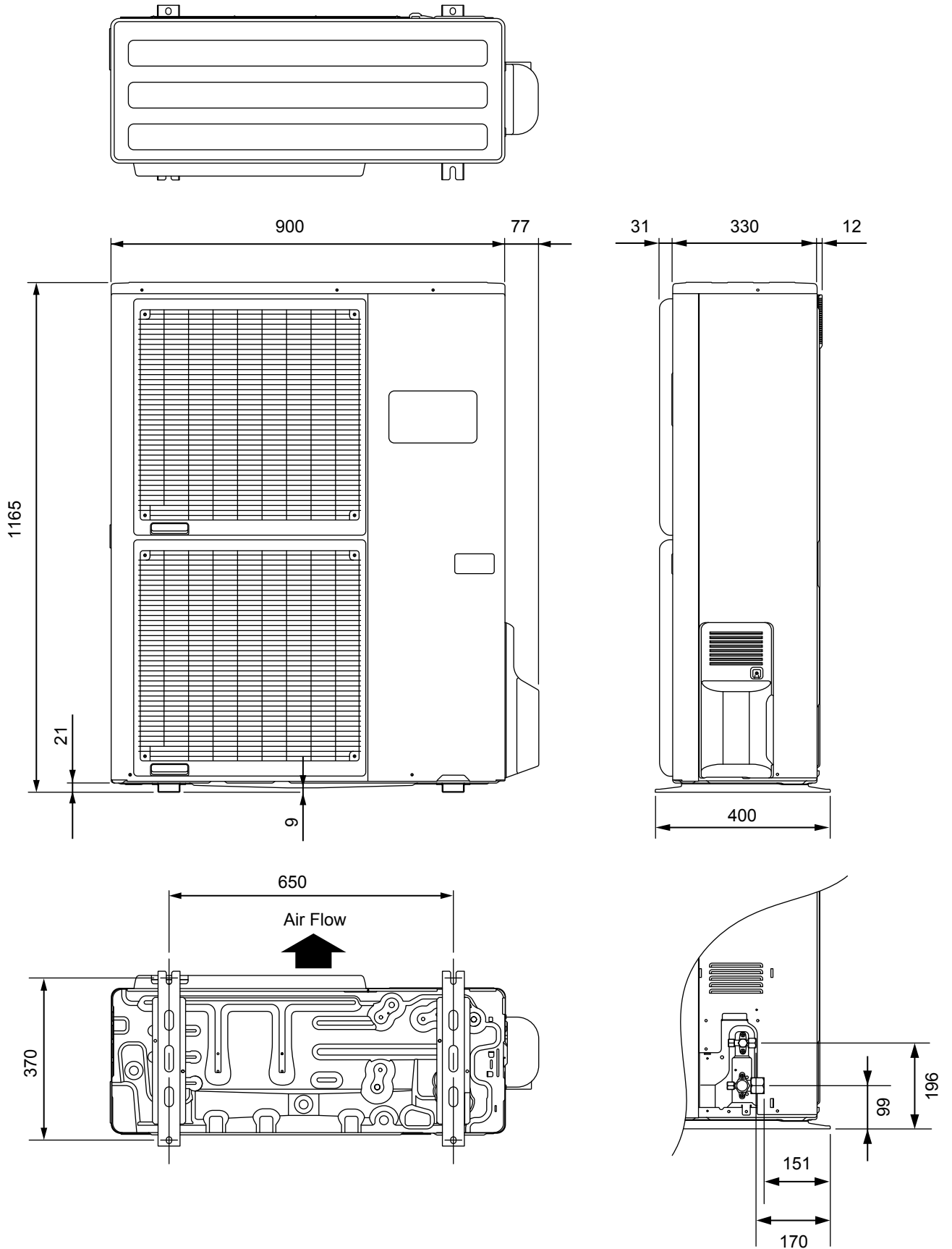

REFRIGERANT SYSTEM DIAGRAM

Models : RD-45FA / RO-45FA

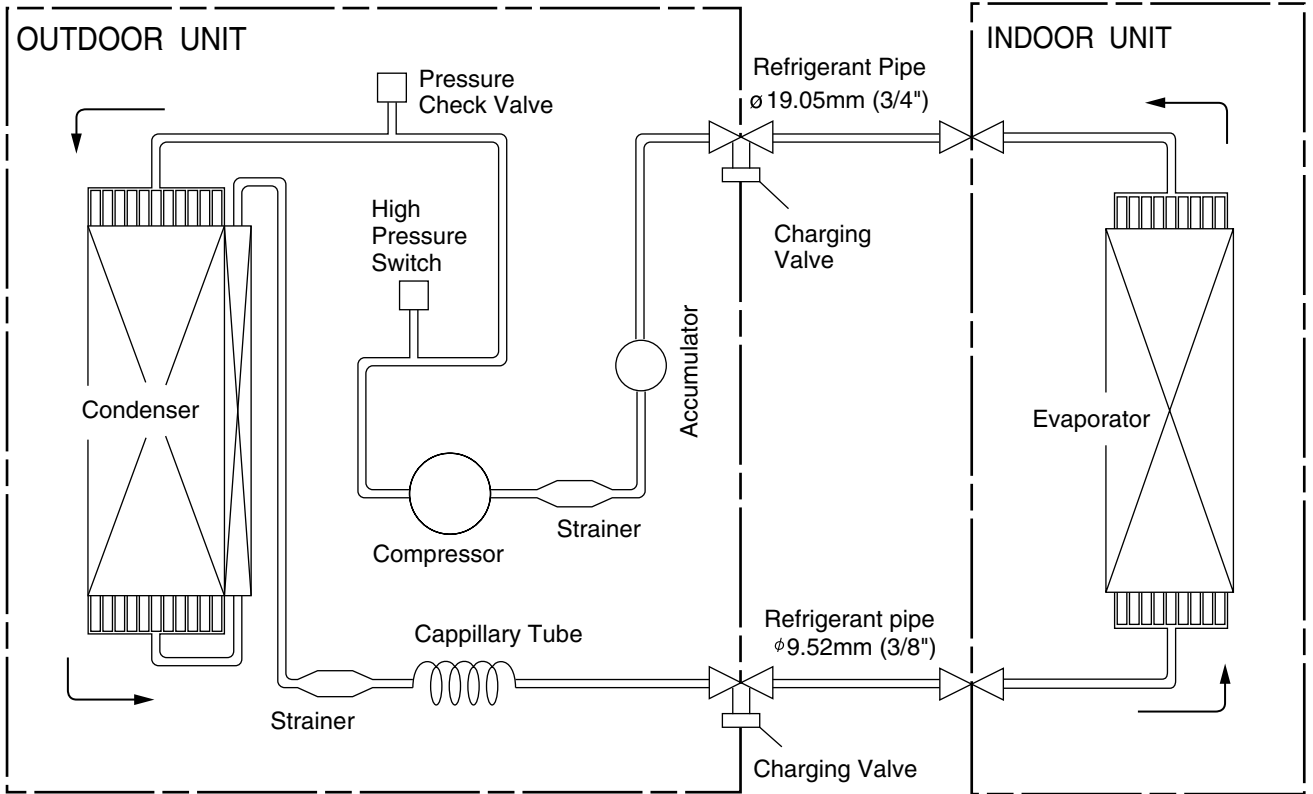

Models : RD-45UA / RO-45UA

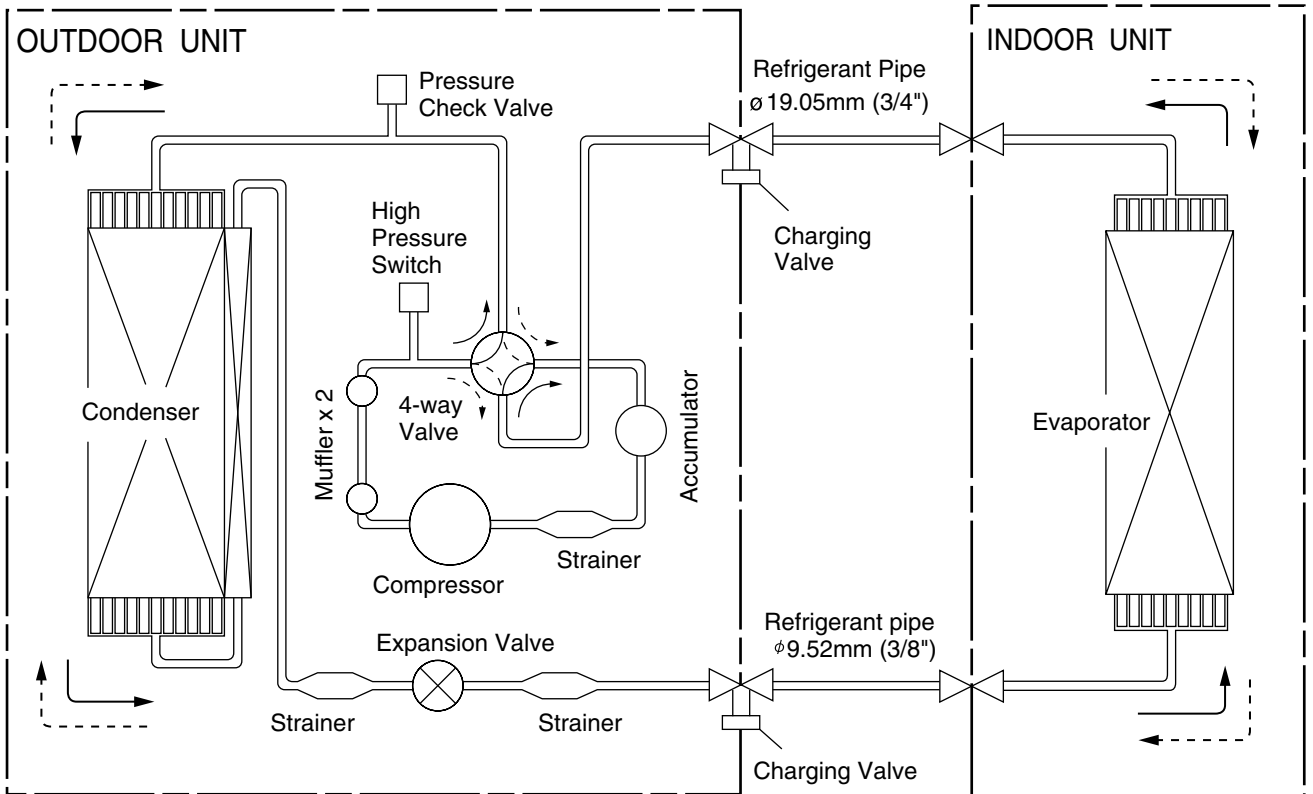

———> : COOL
 - - - -> : HEAT

CIRCUIT DIAGRAM

Model : RD-45FA

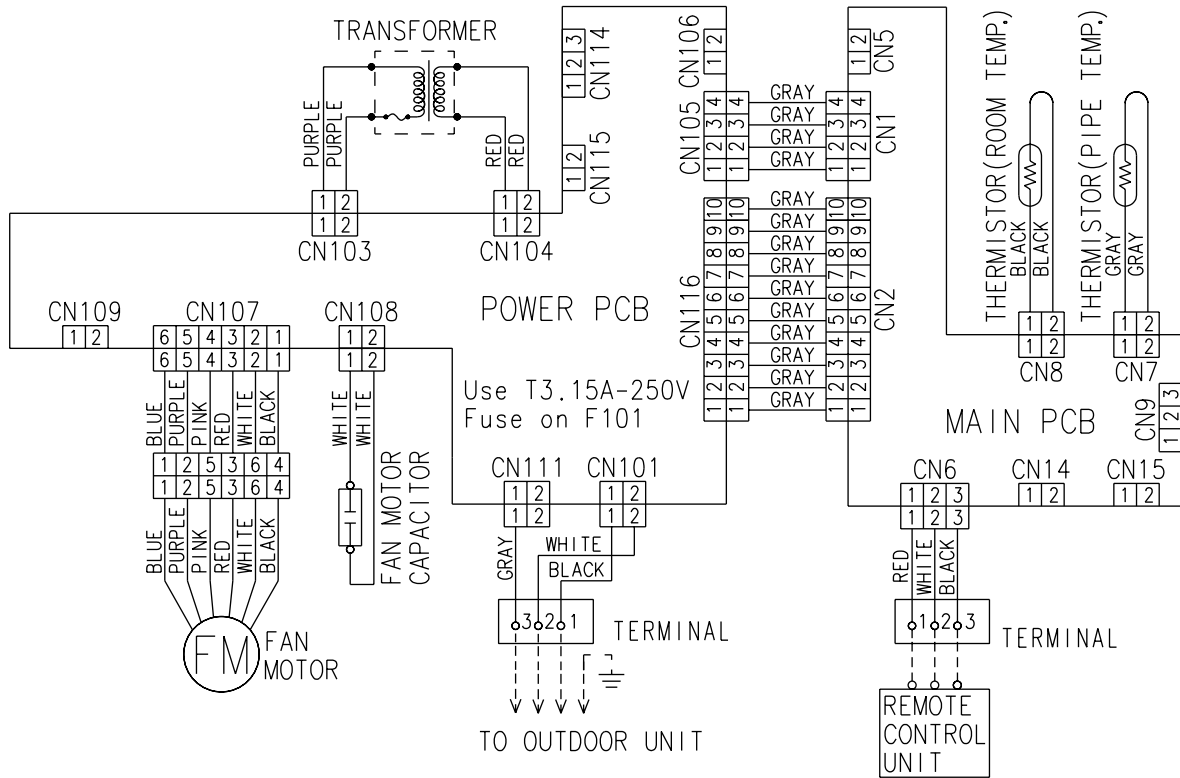

Model : RO-45FA

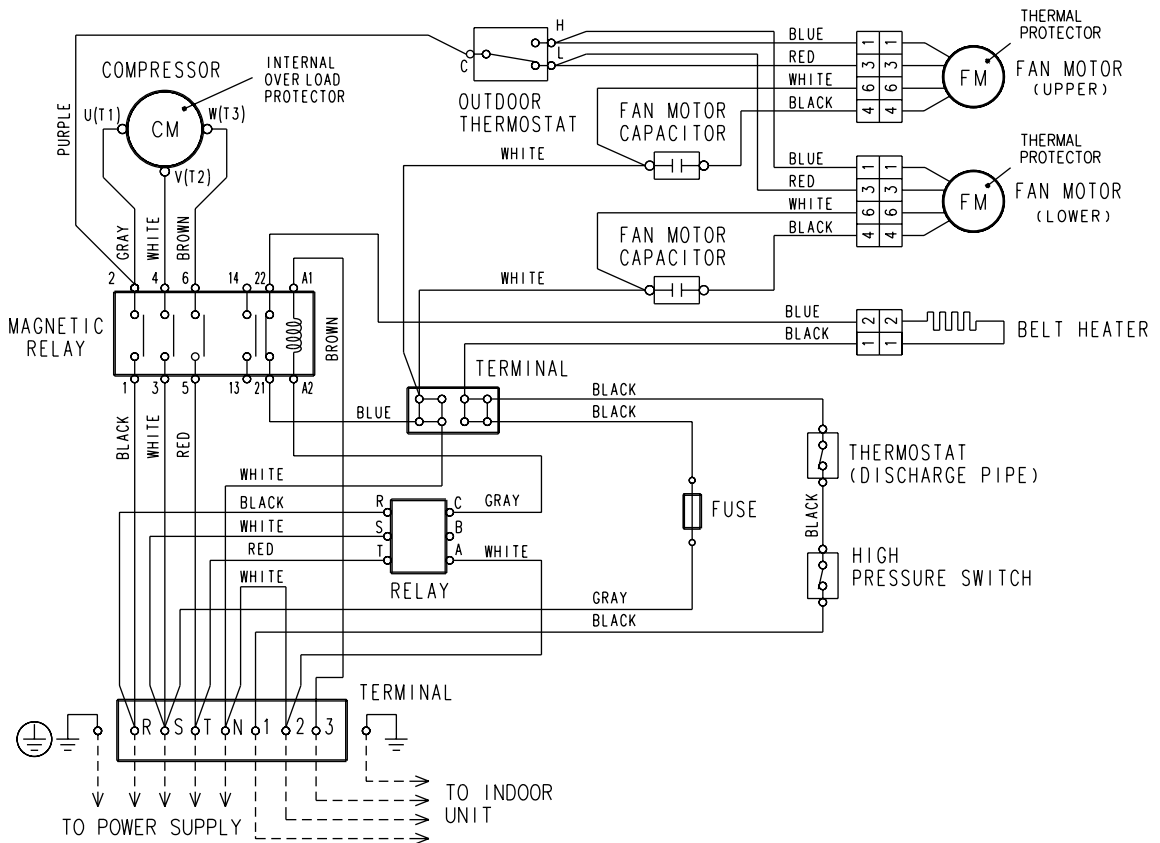

Model : RD-45UA

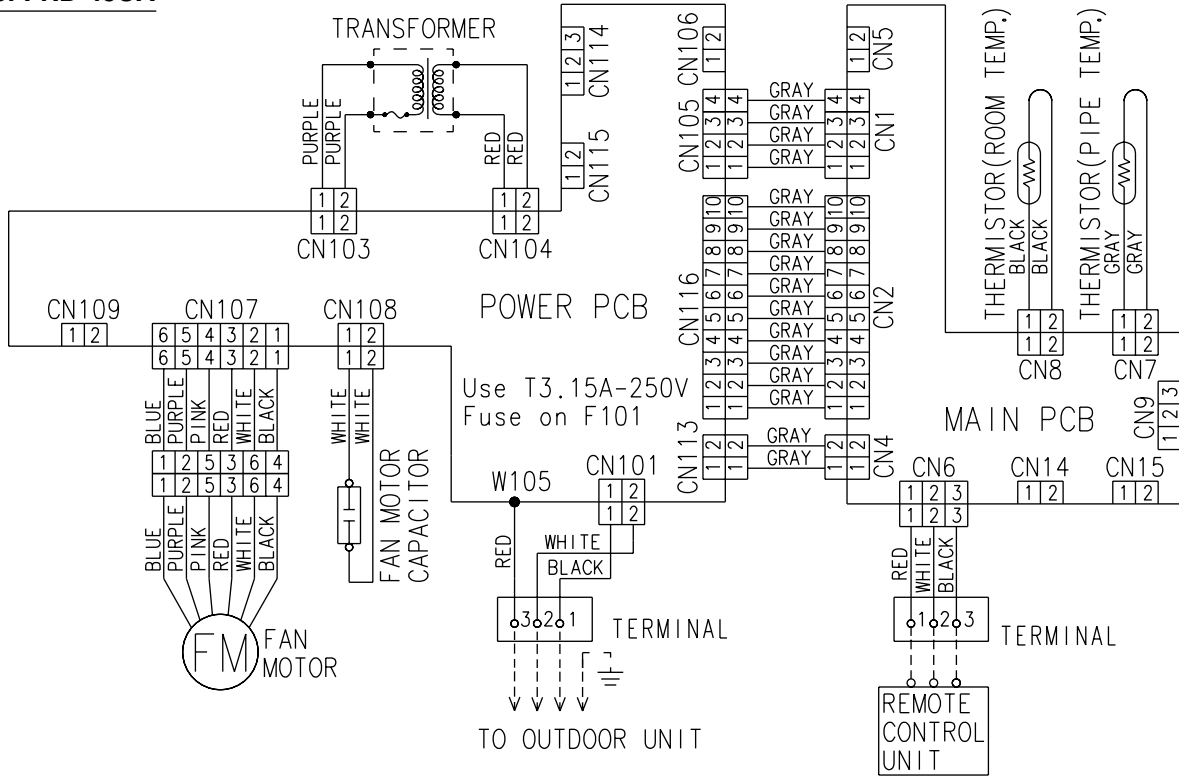

Model : RO-45UA

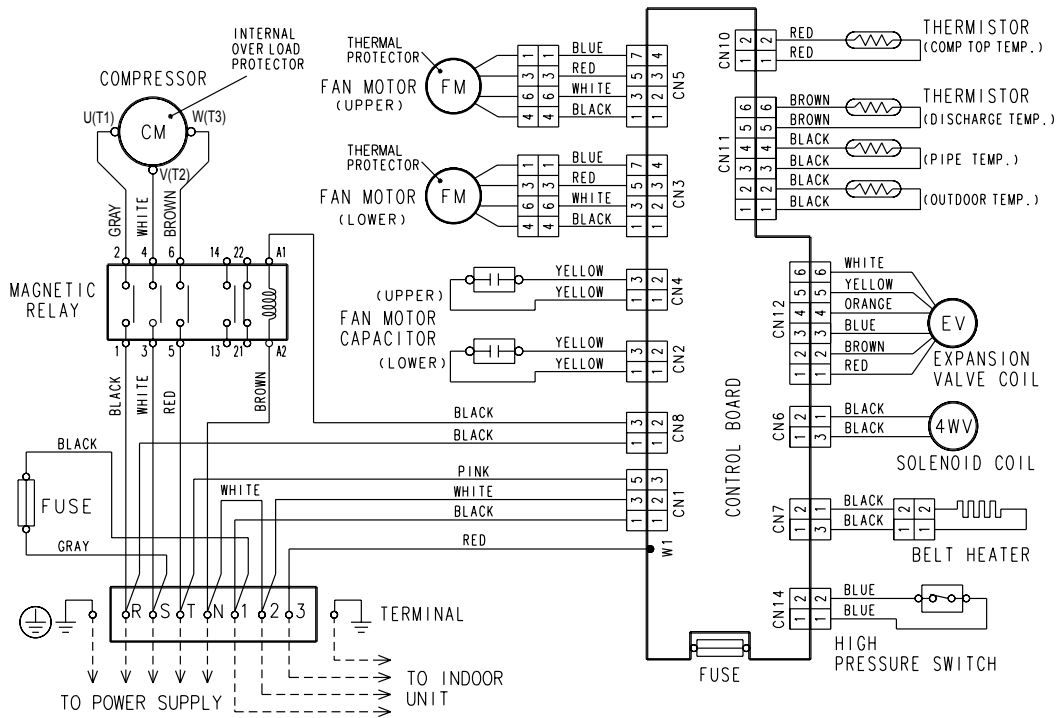

INDOOR PCB CIRCUIT DIAGRAM

Model : RD-45FA

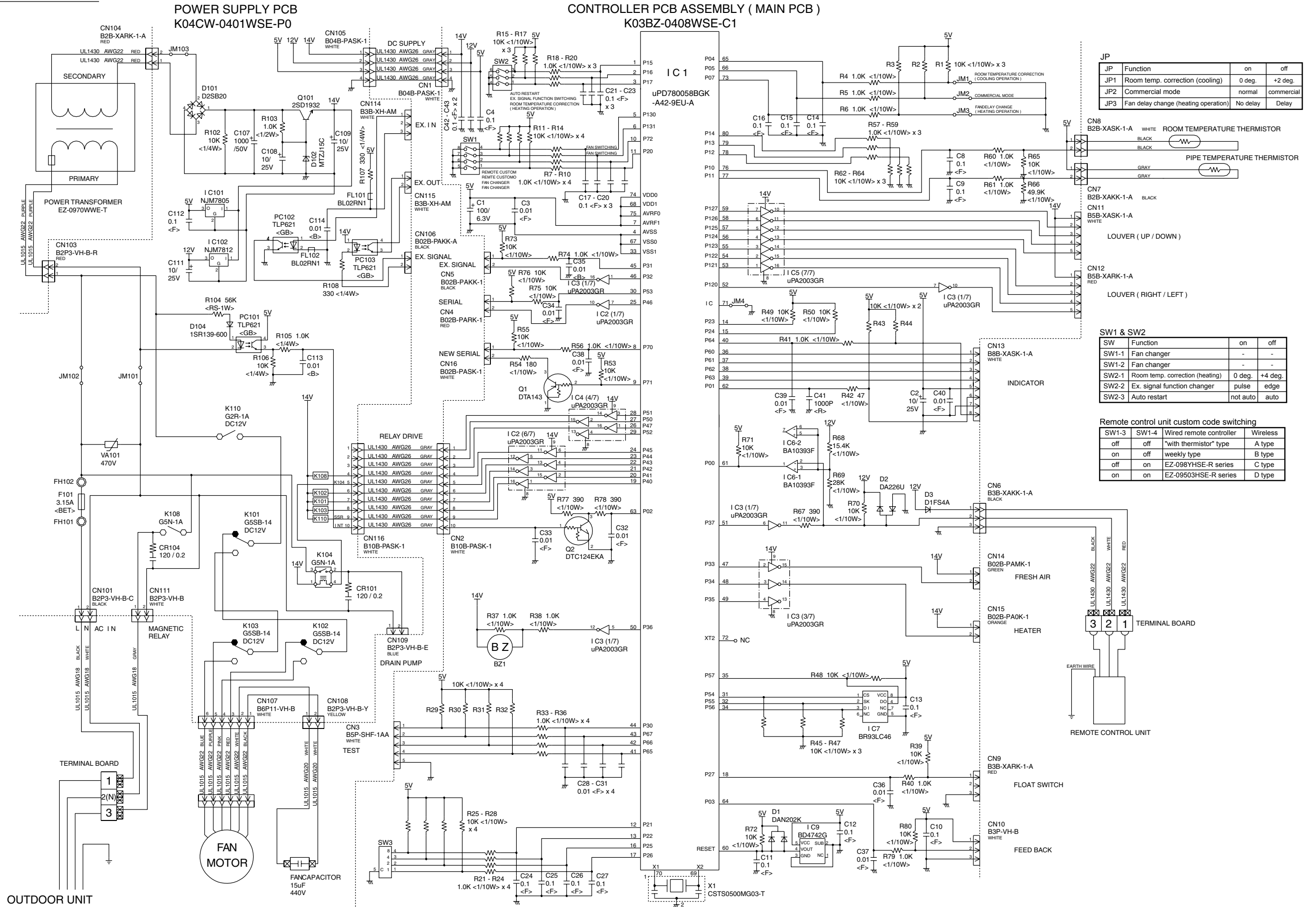

POWER SUPPLY PCB
K04CW-0400HSE-P0

CONTROLLER PCB ASSEMBLY (MAIN PCB)
K03BZ-0409HSE-C1

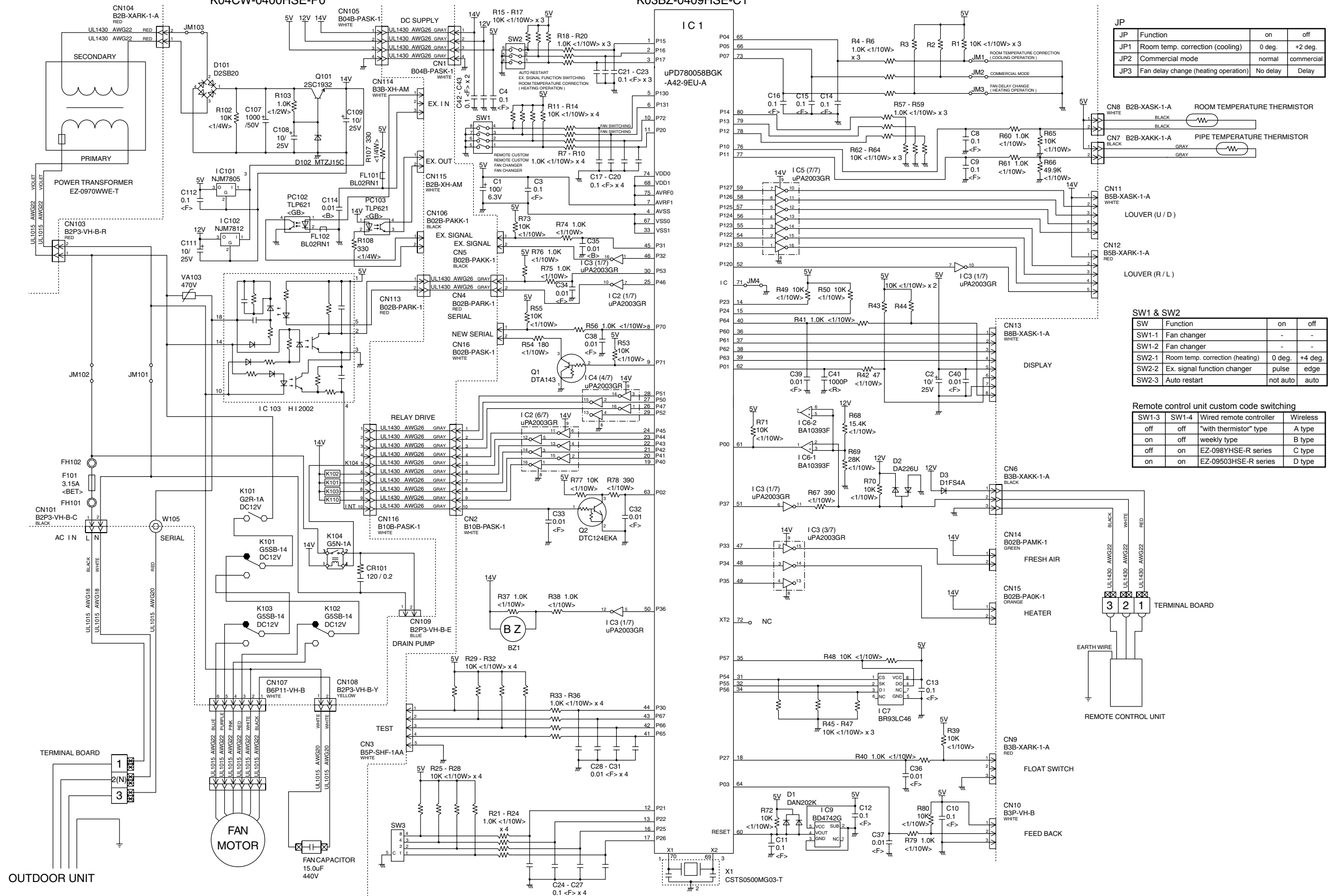

OUTDOOR PCB CIRCUIT DIAGRAM

Model : RO-45UA

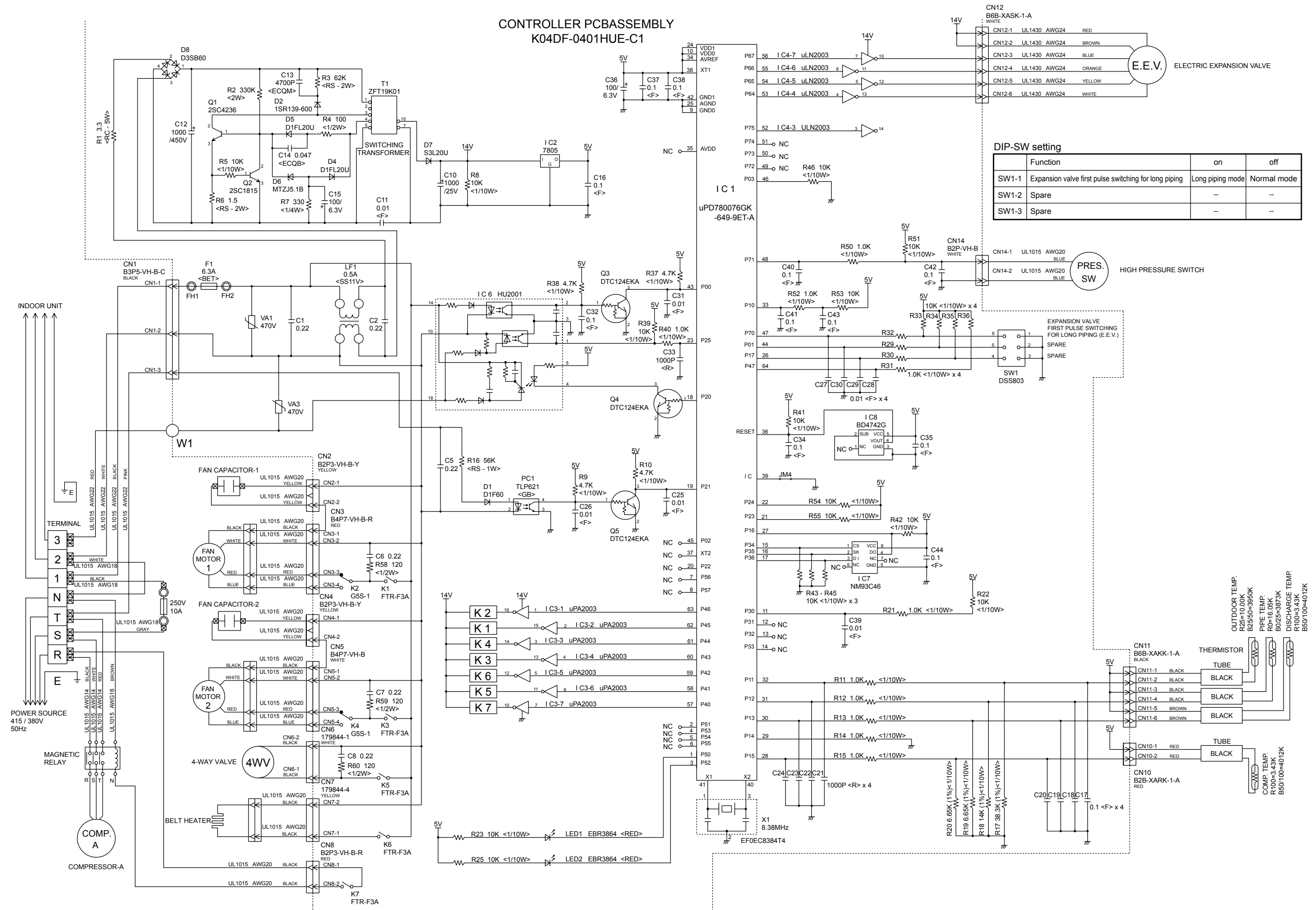

ERROR CONTENTS

CAUTION

Supply power to the crankcase heater for at least 12 hours before the start of operation in winter.

- Stop the air conditioner operation.
- Press the master control button and the fan control button simultaneously for 2 seconds or more to start the test run.

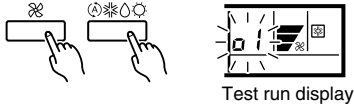

- Press the start/stop button to stop the test run.

[SELF-DIAGNOSIS]

When the error indication "E:EE" is displayed, follow the following items to perform the self-diagnosis. "E:EE" indicates an error has occurred.

1. REMOTE CONTROLLER DISPLAY

- Stop the air conditioner operation.
- Press the set temperature buttons \wedge / \vee simultaneously for 5 seconds or more to start the self-diagnosis. Refer to the following tables for the description of each error code.

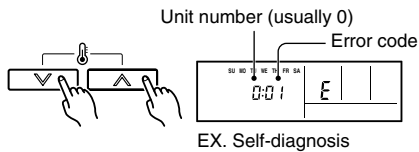

- Press the set temperature buttons \wedge / \vee simultaneously for 5 seconds or more to stop the self-diagnosis.

Error code	Error contents
00	Communication error (indoor unit ↔ remote controller)
01	Communication error (indoor unit ↔ outdoor unit)
02	Room temperature sensor open
03	Room temperature sensor short-circuited
04	Indoor heat exchanger temperature sensor open
05	Indoor heat exchanger temperature sensor short-circuited
06	Outdoor heat exchanger temperature sensor open
07	Outdoor heat exchanger temperature sensor short-circuited
08	Power source connection error
09	Float switch operated
0A	Outdoor temperature sensor open
0b	Outdoor temperature sensor short-circuited

Error code	Error contents
0c	Discharge pipe temperature sensor or compressor temperature sensor open
0d	Discharge pipe temperature sensor or compressor temperature sensor short-circuited
0E	Outdoor high pressure abnormal
0F	Discharge pipe temperature or compressor temperature abnormal
11	Model abnormal
12	Indoor fan abnormal
13	Outdoor signal abnormal
14	Outdoor EEPROM abnormal

2. OUTDOOR UNIT LEDS

Heat & Cool model (reverse cycle) only

When a malfunction occurs in the outdoor unit, the LEDs on the circuit board light to indicate the error. Refer to the following table for the description of each error according to the LEDs.

LED layout

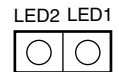

LED1	LED2	Error contents
flash	flash	Model abnormal or EEPROM abnormal
1 flash	Lighting	Power source connection error
2 flash	Lighting	Discharge temp. sensor error
3 flash	Lighting	Heat exchanger temp. sensor error
4 flash	Lighting	Outdoor temp. sensor error
5 flash	Lighting	Communication signal error
6 flash	Lighting	Indoor unit error
7 flash	Lighting	Discharge temp. abnormal
8 flash	Lighting	High pressure abnormal
9 flash	Lighting	Compressor temp. abnormal
10 flash	Lighting	Compressor temp. sensor error
Dislighting		No error. Protect operation

When the fault is cleared, the LED lamp goes off. However, for discharge pipe temperature abnormal and high pressure abnormal, the LED lamp lights continuously for 24 hours, as long as the power is not turned off.

DISASSEMBLY ILLUSTRATION

Models : RD-45FA, RD-45UA

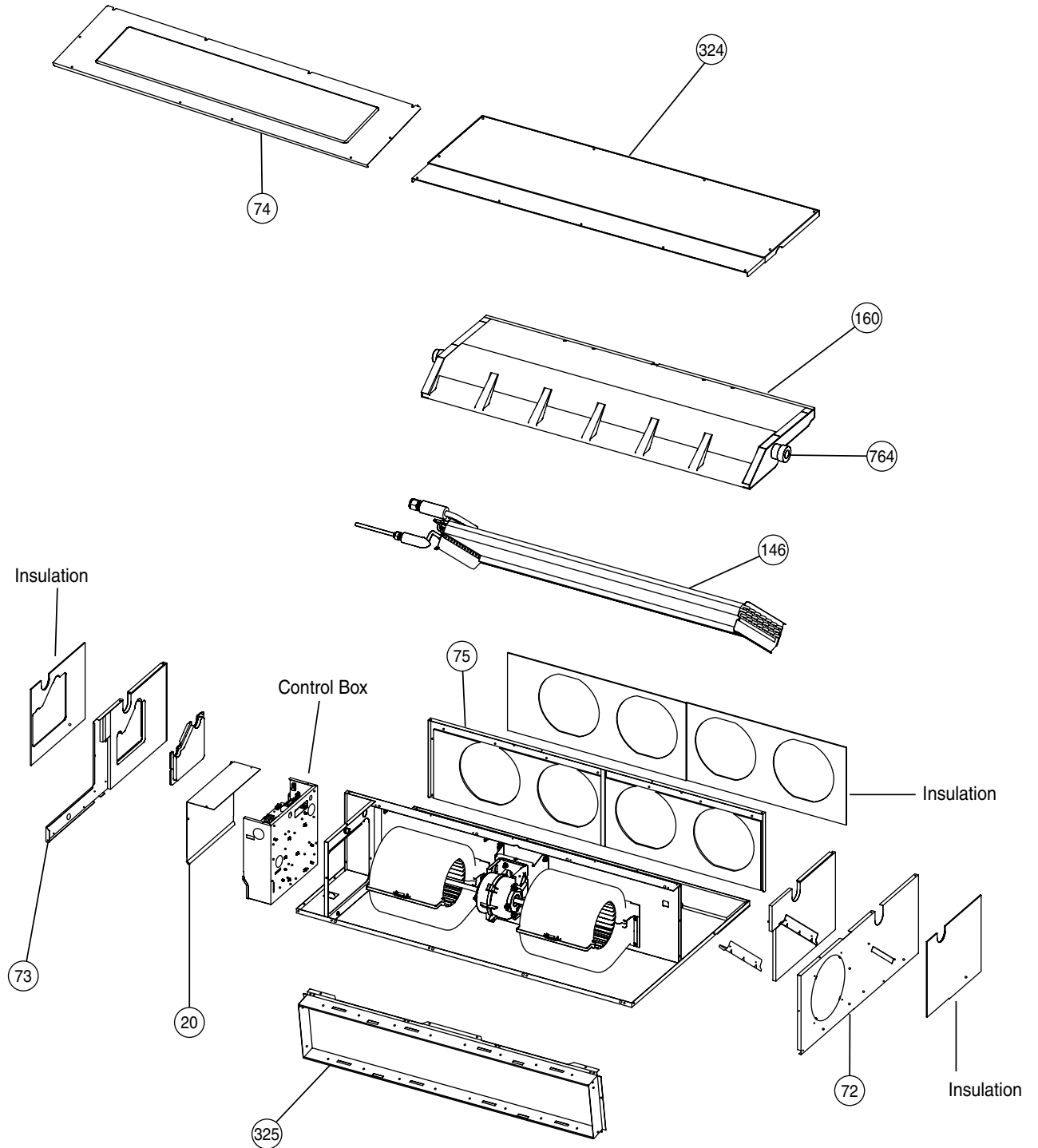

Models : RD-45FA, RD-45UA

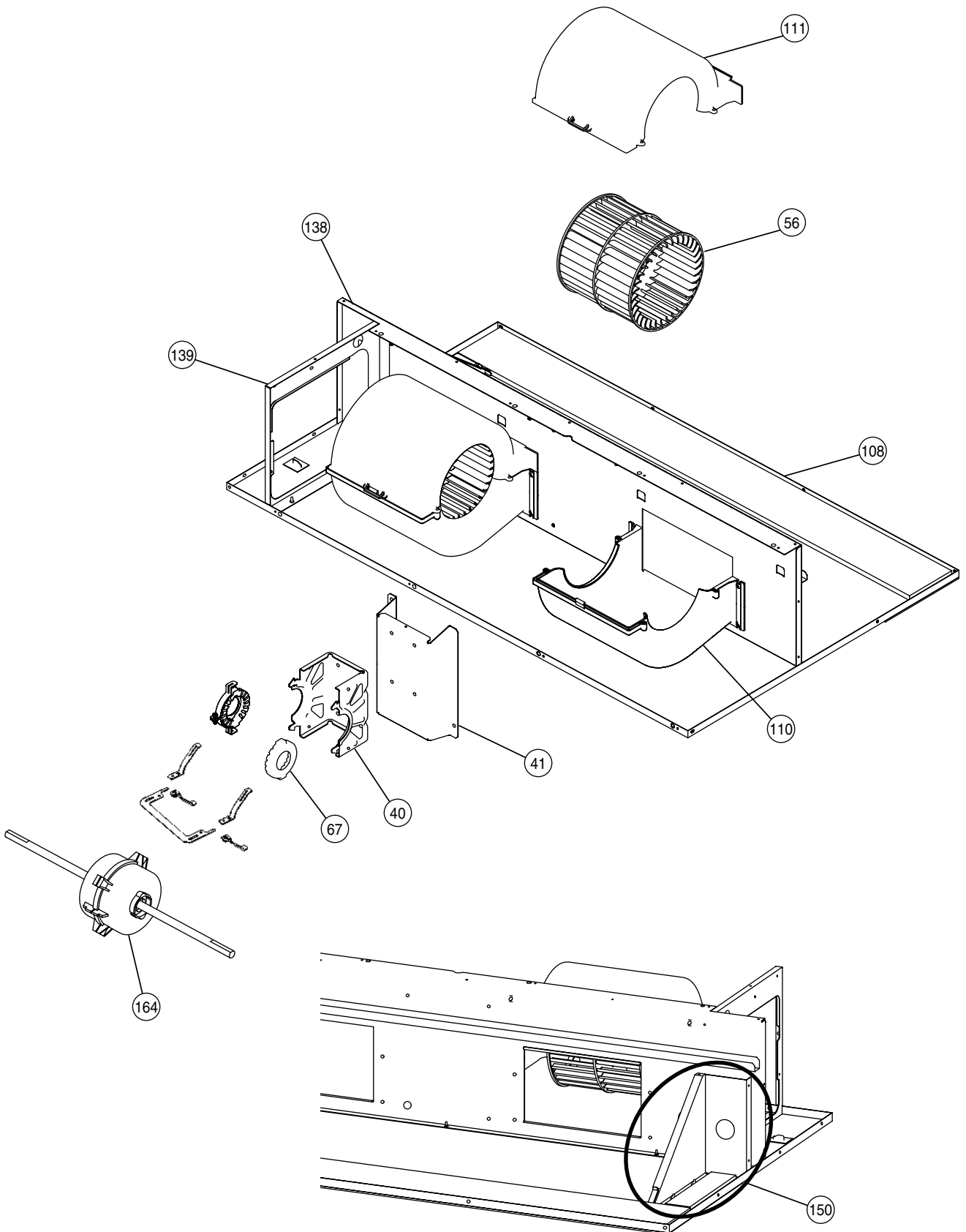

Models : RD-45FA, RD-45UA

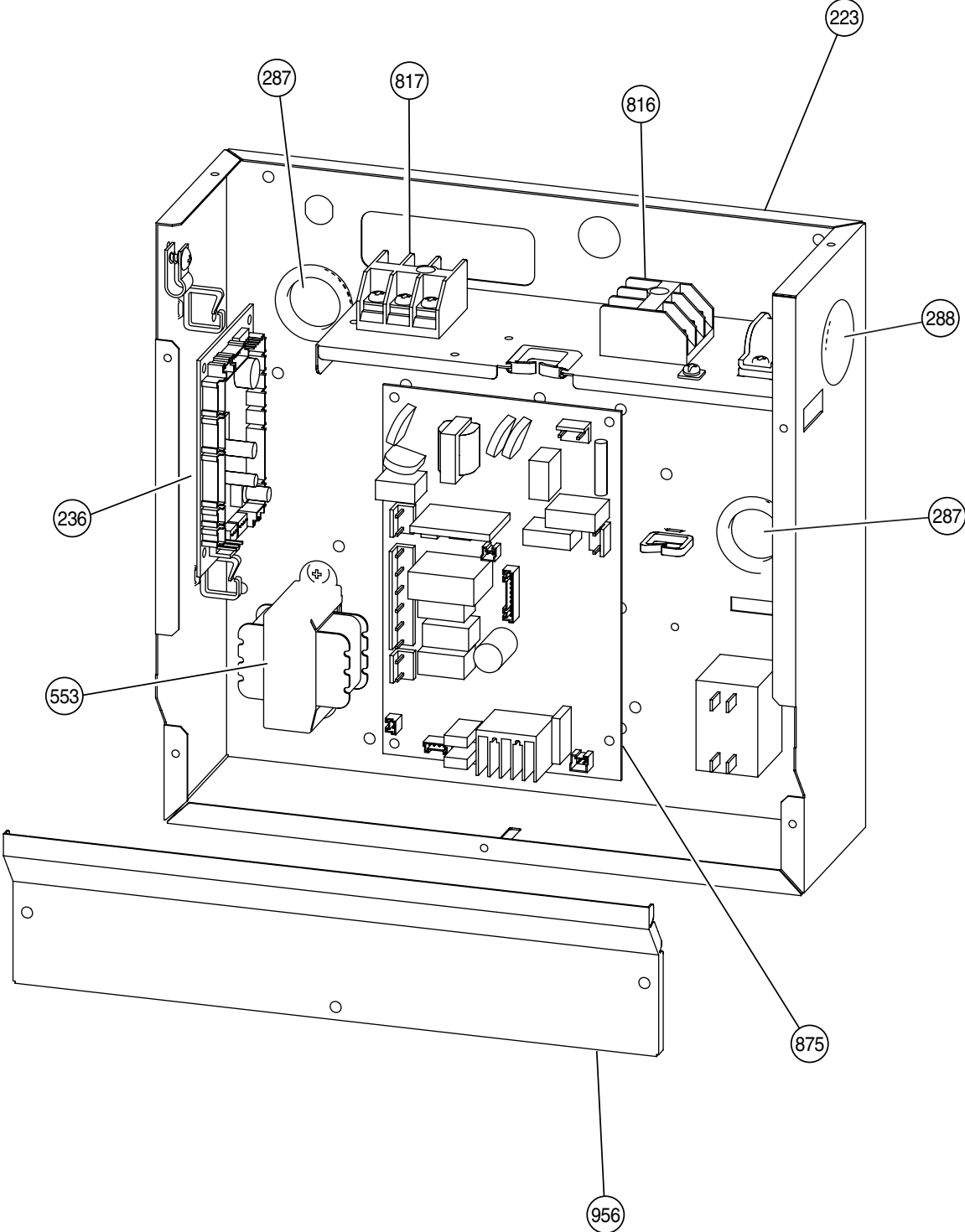

Models : RO-45FA, RO-45UA

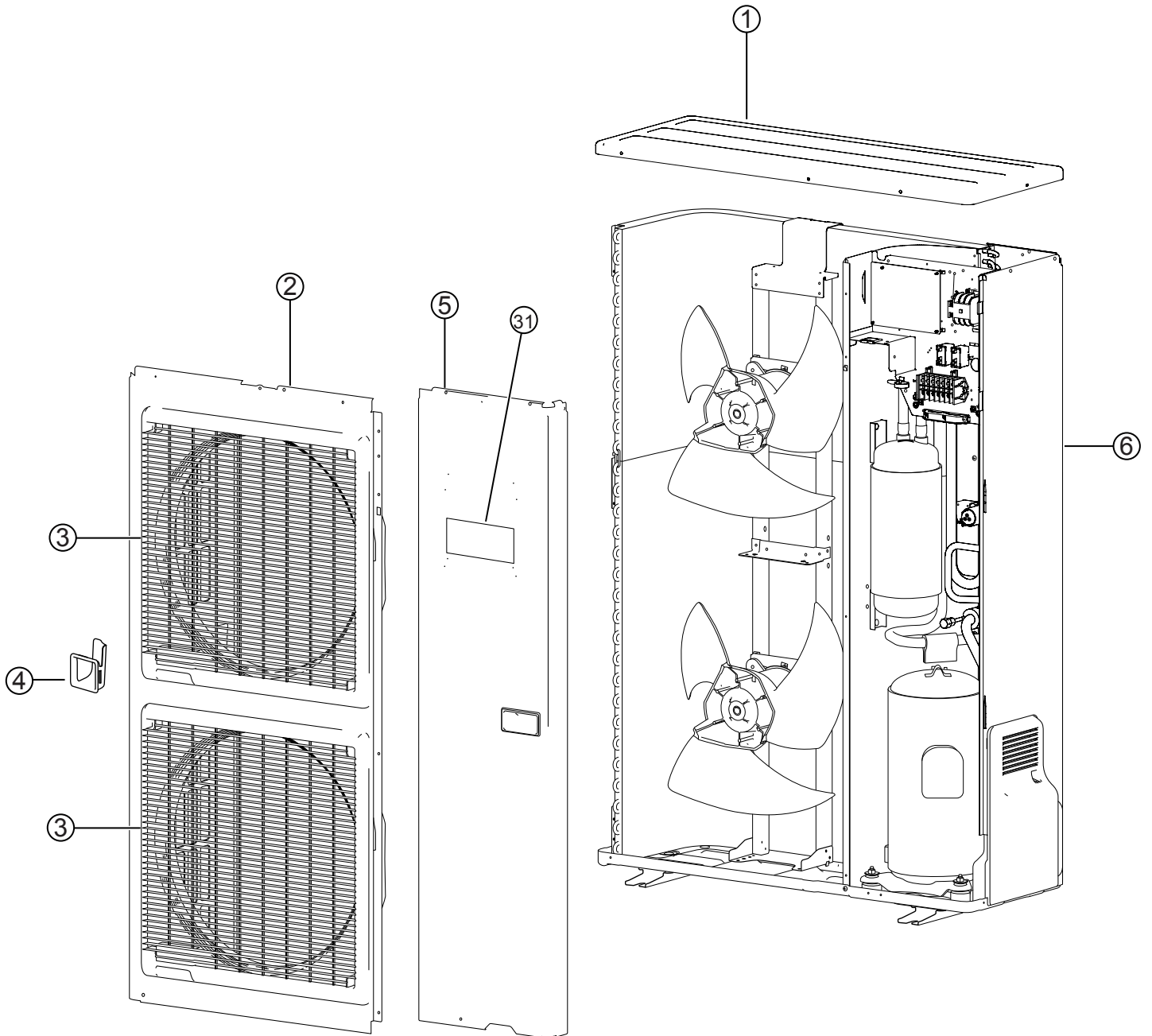

Model : RO-45FA

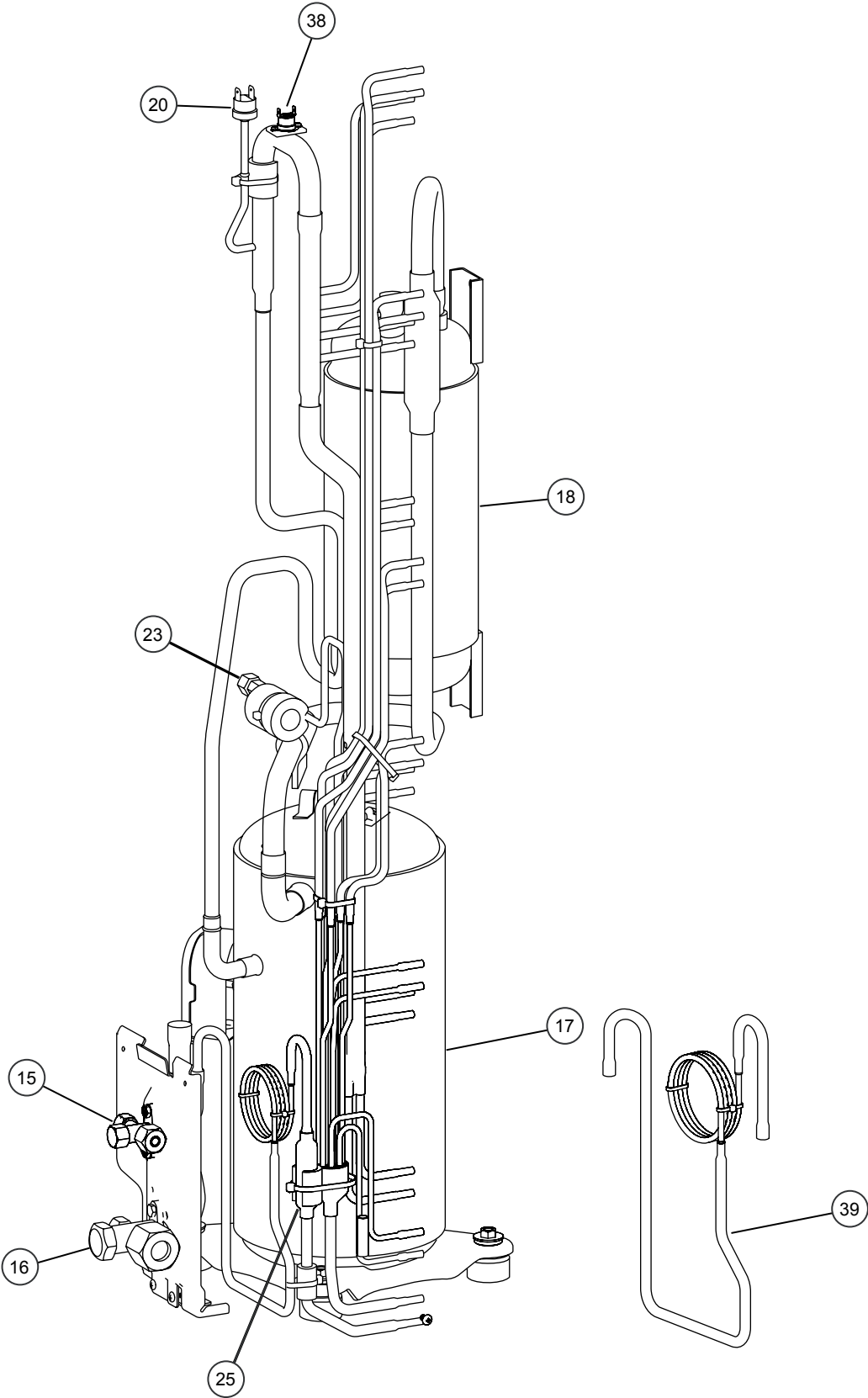

Model : RO-45UA

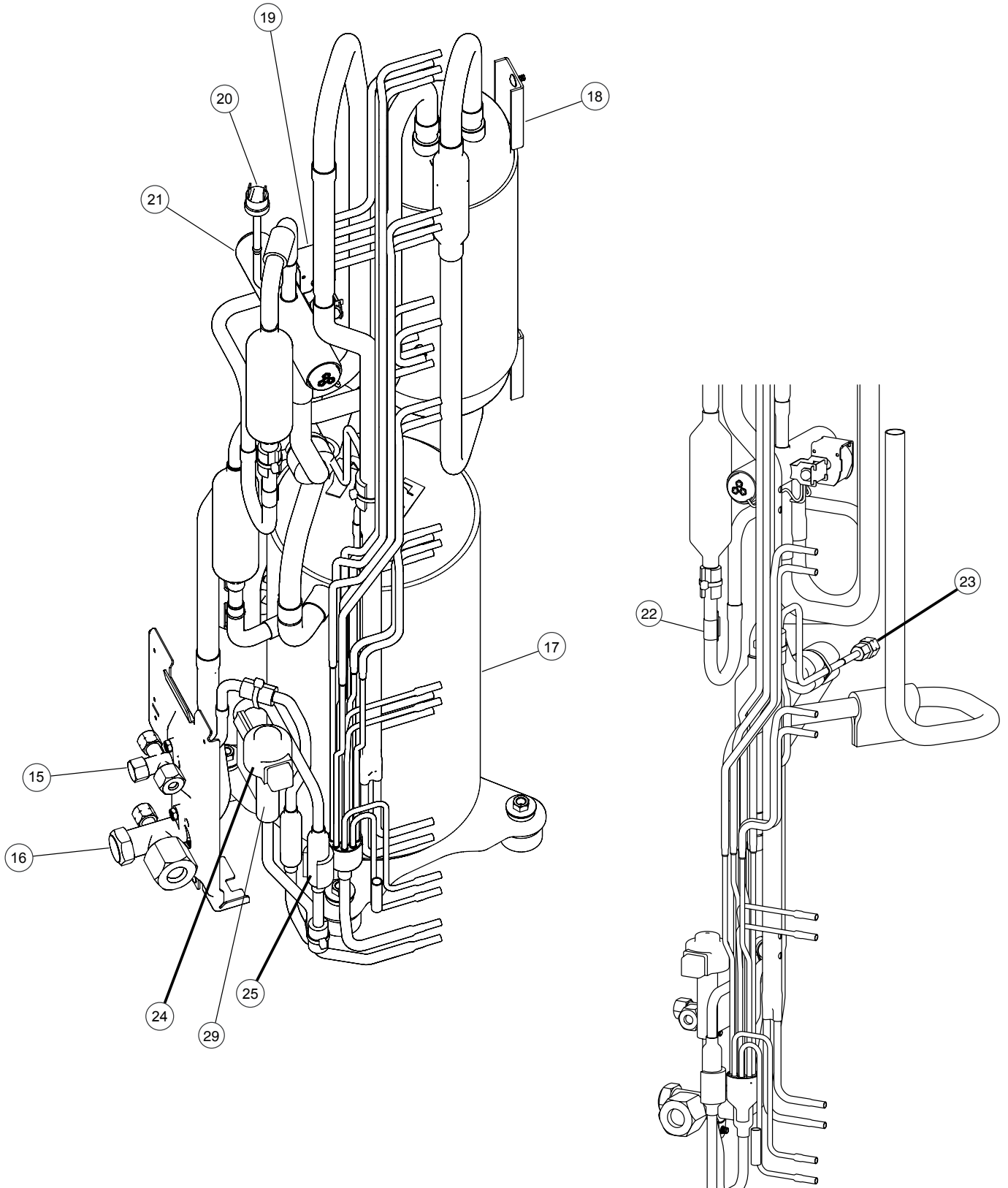

Model : RO-45FA

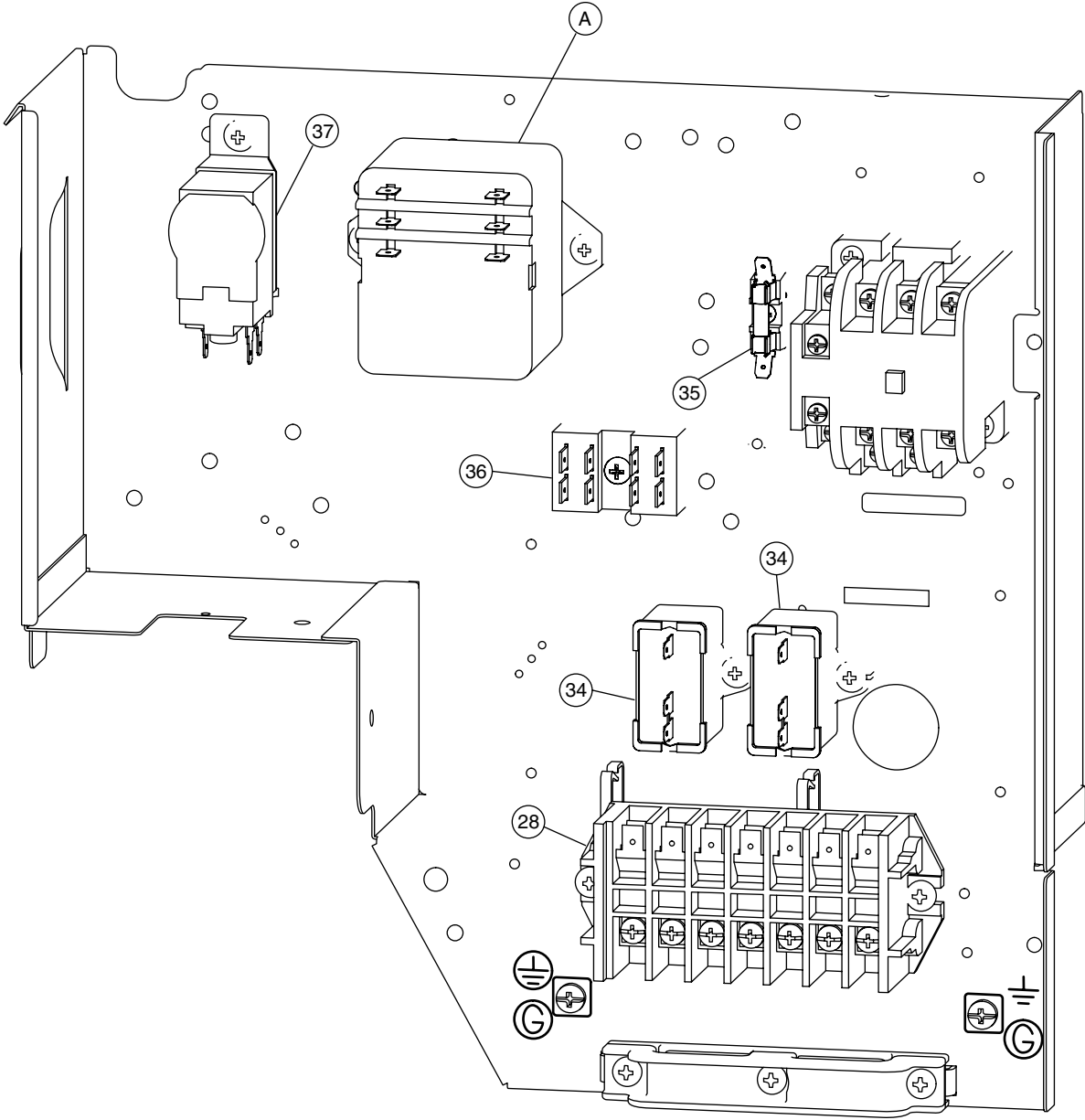

Model : RO-45UA

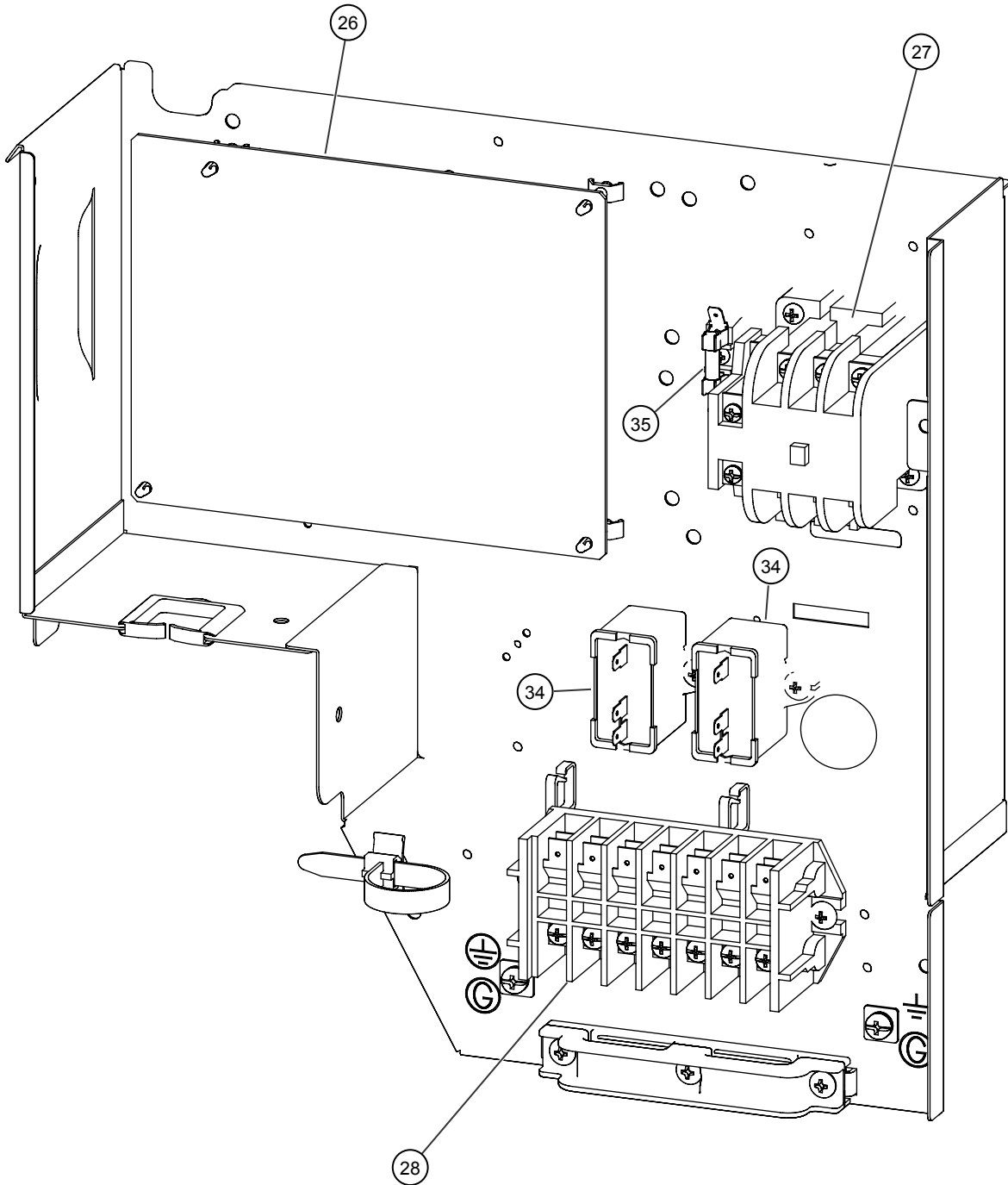

PARTS LIST

INDOOR UNIT

Ref. No.	Description	Part No.		Ord. Q'ty
		RD-45FA	RD-45UA	
20	Control Cover-A Sub Assy	9374516018	9374516018	
40	Motor Mount	9374281015	9374281015	
41	Bracket Motor Assy	9374230013	9374230013	
56	Sirocco Fan Assy	9356531022	9356531022	
67	Rubber	313659068604	313659068604	
72	Cabinet-L Sub Assy	9374509010	9374509010	
73	Cabinet-R Sub Assy	9374508013	9374508013	
74	Intake Cover Sub Assy	9374512010	9374512010	
75	Outlet panel Sub Assy	9374510016	9374510016	
108	Base Sub Assy	9374504015	9374504015	
110	Casing-A	9374233014	9374233014	
111	Casing-B	9374234011	9374234011	
138	Separate Wall Assy	9374228010	9374228010	
139	Panel (Control Box) Sub Assy	9374506019	9374506019	
146	Evaporator Assy	9372585047	9372585047	
150	Bracket (Evaporator)-R	9374207015	9374207015	
160	Drain Pan Sub Assy	9374513017	9374513017	
164	Motor, Induction	9600830093	9600830093	
223	Control Box-A	9374219018	9374219018	
236	Controller PCB Assy	9705246089	9705246096	
287	Cap (POWER)	9352173011	9352173011	
288	One Touch Bush	9374407019	9374407019	
324	Main Panel Sub Assy	9374511013	9374511013	
325	Intake Frame Assy	9374216017	9374216017	
553	Power Transformer	9704129017	9704129017	
764	Drain Cap	9356541007	9356541007	
816	Terminal-3P	9703345012	9703345012	
817	Terminal-3P	9306489045	9306489045	
875	Power Supply PCB Assy	9705668027	9705668010	
956	Control Cover-B	9374222018	9374222018	
----	Thermistor SPRING-a	313728262708	313728262708	
----	Room Temperature Thermistor	9703299025	9703299025	
----	Pipe Temperature Thermistor	9703297021	9703297021	
----	Remote Control Unit Assy	9372266021	9372266014	
----	RFM (Motor Band)	9374646012	9374646012	
----	Motor Band-B	9374648023	9374648023	
----	Control Box-B	9374220014	9374220014	
----	Motor Band-A Assy	9374647019	9374647019	
----	Wire w/Connector	9704856012	9704856012	
----	Wire w/Connector	-----	9705245020	
----	Wire w/Connector	9705243026	9705243026	
----	Wire w/Connector	9705244023	9705244023	

When you order parts, please make a photocopy of this page and fill the number of the parts in the "Order" column.









OUTDOOR UNIT

Ref. No.	Description	Part No.		Ord. Q'ty
		RO-45FA	RO-45UA	
1	Top Panel Sub Assy	9374417018	9374417018	
2	Front Panel-L, Painted	9374094042	9374094042	
3	Fan Guard	9374330010	9374330010	
4	Side Grip	9374173013	9374173013	
5	Service Panel Sub Assy	9374415021	9374415021	
6	Right Panel Sub Assy	9374416028	9374416028	
7	Motor Bracket Sub Assy	9374418022	9374418022	
8	Propeller Fan Assy	9366378013	9366378013	
9	Motor, Induction	9601671060	9601671060	
10	Condenser-A Assy	9374433070	9374433032	
11	Condenser-B Assy	9374434053	9374434039	
12	Separate Wall-L	9374135028	9374135028	
13	Cap Foot	9374345014	9374345014	
14	Base Assy	9374166022	9374166022	
15	3-Way Valve Assy	9372205044	9372205044	
16	3-Way Valve Assy	9372205099	9372205099	
17	Compressor Assy	9374251018	9374251018	
18	Accumulator Assy	9371615011	9371615011	
19	Solenoid	-----	9900165055	
20	Pressure Switch	9900276010	9900186012	
21	4-Way Valve	-----	9900164010	
22	Discharge Temperature Thermistor	-----	9900277017	
23	Check Valve Assy	9374274017	9374274017	
24	Coil (Expansion Valve)	-----	9900190026	
25	Strainer Assy	9372524015	9372524015	
26	Controller PCB Assy	-----	9705677029	
27	Magnetic Relay	-----	9900227012	
28	Terminal-7P	9363276039	9363276039	
29	Expansion Valve	-----	9900170011	
31	Emblem Rear	9361328006	9361328006	
34	Capacitor (Fan Motor)	9900270049	9900270049	
35	Fuse	0600376086	0600376086	
36	Terminal-2P	9701971015	-----	
37	Thermostat (Outdoor)	9900275013	-----	
38	Thermostat (Overheat)	9354061002	-----	
39	Capillary Assy	9372197356	-----	
A	Relay	9900287016	-----	
----	Thermistor Assy	-----	9900274016	
----	Drain Cap	-----	313166024302	
----	Drain Pipe	-----	9301102000	

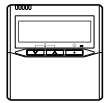

When you order parts, please make a photocopy of this page and fill the number of the parts in the "Order" column.

STANDARD ACCESSORIES

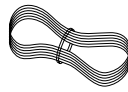
INDOOR UNIT ACCESSORIES

Name and Shape	Q'ty	Application	Part No.	
			RD-45FA	RD-45UA
Hanger 	4	For suspending the indoor unit from ceiling	9356563009	9356563009
Special nut A (large flange) 	4	For suspending the indoor unit from ceiling	313005446653	313005446653
Special nut B (small flange) 	4		313005446759	313005446759
Coupler heat insulation (large) 	2	For indoor side pipe joint (large pipe)	9350716029	9350716029
Coupler heat insulation (small) 	1	For indoor side pipe joint (small pipe)	9352766015	9352766015
Nylon fastener 	1 (large)	For fixing the drain hose	312300787605	312300787605
	1 (small)	For fixing the remote controller cord	313361275805	31361275805
Remote control unit 	1		9372266021	9372266014
Tapping screw 	2	For installing the remote control unit cord clamp	0700181108	0700181108
Drain hose insulation 	1	Insulates the drain hose and vinyl hose connection	313806217708	313806217708
Remote controller cord 	1		9372714010	9372714010

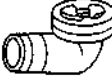
OUTDOOR UNIT ACCESSORIES

Name and Shape	Q'ty	Application	Part No.	
			RO-45FA	RO-45UA
Drain pipe 	1	For outdoor unit drain piping work (May not be supplied, depending on the model.)	----	9303029015
Drain cap 	2		----	313166024302
Insulation (seal) 	1	For filling in a gap at the entrance of connection cords	9374756018	9374756018

0505G2865