

Refrigerant R410A Duct Type SPLIT TYPE AIR CONDITIONER INSTALLATION INSTRUCTION SHEET

(PART NO. 9374536078-03)

Indoor unit is an appliance not accessible to the general public.

For authorized service personnel only.

- WARNING** This mark indicates procedures which, if improperly performed, might lead to the death or serious injury of the user.
- CAUTION** This mark indicates procedures which, if improperly performed, might possibly result in personal harm to the user, or damage to property.

This air conditioner uses new refrigerant HFC (R410A).

The basic installation work procedures are the same as conventional refrigerant models. However, pay careful attention to the following points:

- Since the working pressure is 1.6 times higher than that of conventional refrigerant models, some of the piping and installation and service tools are special. (See the table below.) Especially, when replacing a conventional refrigerant model with a new refrigerant R410A model, always replace the conventional piping and flare nuts with the R410A piping and flare nuts.
- Models that use refrigerant R410A have a different charging port thread diameter to prevent erroneous charging with conventional refrigerant and for safety. Therefore, check beforehand. [The charging port thread diameter for R410A is 1/2 UNF 20 threads per inch.]
- Be more careful that foreign matter (oil, water, etc.) does not enter the piping than with refrigerant models. Also, when storing the piping, securely seal the openings by pinching, taping, etc.
- When charging the refrigerant, take into account the slight change in the composition of the gas and liquid phases, and always charge from the liquid phase side whose composition is stable.
- When moving, if the compressor stops during pump down, close the valve immediately. (45 type only.)

Special tools for R410A

Tool name	Contents of change
Gauge manifold	Pressure is high and cannot be measured with a conventional gauge. To prevent erroneous mixing of other refrigerants, the diameter of each port has been changed. It is recommended the gauge with seals -0.1 to 5.3 MPa (-76 cmHg to 53 kgf/cm ²) for high pressure, -0.1 to 3.8 MPa (-76 cmHg to 38 kgf/cm ²) for low pressure.
Charge hose	To increase pressure resistance, the hose material and base size were changed.
Vacuum pump	A conventional vacuum pump can be used by installing a vacuum pump adapter.
Gas leakage detector	Special gas leakage detector for HFC refrigerant R410A.

Copper pipes

It is necessary to use seamless copper pipes and it is desirable that the amount of residual oil is less than 40 mg/10m. Do not use copper pipes having a collapsed, deformed or discolored portion (especially on the interior surface). Otherwise, the expansion valve or capillary tube may become blocked with contaminants. As an air conditioner using R410A incurs pressure higher than when using conventional refrigerant, it is necessary to choose adequate materials. Thicknesses of copper pipes used with R410A are as shown in the table. Never use copper pipes thinner than that in the table even when it is available on the market.

Thicknesses of Annealed Copper Pipes (R410A)

Pipe outside diameter	Thickness
6.35 mm (1/4 in.)	0.80 mm
9.52 mm (3/8 in.)	0.80 mm
12.70 mm (1/2 in.)	0.80 mm
15.88 mm (5/8 in.)	1.00 mm
19.05 mm (3/4 in.)	1.20 mm

STANDARD PARTS

The following installation parts are furnished. Use them as required.

INDOOR UNIT ACCESSORIES

Name and Shape	Q'ty	Application	Name and Shape	Q'ty	Application
Hanger	4	For suspending the indoor unit from ceiling	Binder	1 (large) 1 (small)	For fixing the drain hose For fixing the remote controller cable
Special nut A (large flange)	4	For suspending the indoor unit from ceiling	Remote controller	1	
Special nut B (small flange)	4		Tapping screw (flush heads)	2	For installing the remote controller
Coupler heat insulation (large)	1	For indoor side pipe joint (gas pipe)	Remote controller cable	1	For connecting the remote controller
Coupler heat insulation (small)	1	For indoor side pipe joint (liquid pipe)	Drain hose insulation	1	Insulates the drain hose and vinyl hose

OUTDOOR UNIT ACCESSORIES

Drain pipe	1	For outdoor unit drain piping work	Insulation (seal)	1	For filling in a gap at the entrance of connection cables
Drain cap	2	[Heat & Cool model (Reverse cycle) only]			

OPTIONAL PARTS

When connecting the square duct and round duct, use the optional square flange or round flange.

Square flange

Model name : UTD-SF045T (P/N 9098180007)

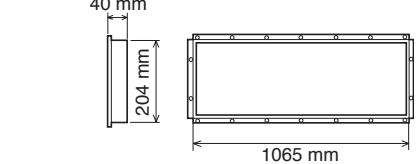

Long-life filter

Model name : UTD-LF25NA (P/N 9079892004)

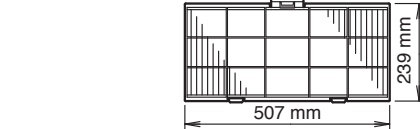

Round flange

Model name : UTD-RF204 (P/N 9093160004)

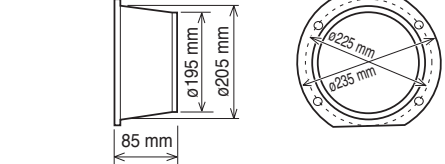

Remote sensor

Model name : UTD-RS100 (P/N 9072619004)

External control wire set

Model name : UTD-ECS5A (P/N 9077359004)

CONNECTING PIPE REQUIREMENT

CAUTION
The maximum lengths of this product are shown in the following table. If the units are further apart than this, correct operation cannot be guaranteed.

	Diameter		Pipe length		Maximum height (between indoor and outdoor)
	Liquid	Gas	MAX.	MIN.	
45,000 BTU/h class	9.52 mm (3/8 in.)	19.05 mm (3/4 in.)	50 m	5 m	30 m
36,000 BTU/h class	9.52 mm (3/8 in.)	15.88 mm (5/8 in.)			

* Use pipe with water-resistant heat insulation.

CAUTION
Install heat insulation around both the gas and liquid pipes. Failure to do so may cause water leaks. Use heat insulation with heat resistance above 120 °C. (Reverse cycle model only). In addition, if the humidity level at the installation location of the refrigerant piping is expected to exceed 70%, install heat insulation around the refrigerant piping. If the expected humidity level is 70-80%, use heat insulation that is 15 mm or thicker and if the expected humidity exceeds 80%, use heat insulation that is 20 mm or thicker. If heat insulation is used that is not as thick as specified, condensation may form on the surface of the insulation. In addition, use heat insulation with heat conductivity of 0.045 W/(m·K) or less (at 20 °C).

ELECTRICAL REQUIREMENT

* Electric wire size and breaker capacity:

	Power supply cable (mm ²)		Connection cable (mm ²)		Breaker capacity (A)
	MAX.	MIN.	MAX.	MIN.	
45,000 BTU/h class (3 phase TYPE)	4.0	2.5	2.5	1.0	20
36,000 BTU/h class (3 phase TYPE)	6.0	4.0			30

- Always use H07RN-F or equivalent to the connection cable.
- Install all electrical works in accordance to the standard.
- Install the disconnect device with a contact gap of at least 3 mm in all poles nearby the units. (Both indoor unit and outdoor unit)
- Install the circuit breaker nearby the units.

SELECTING THE MOUNTING POSITION

Decide the mounting position with the customer as follows:

- WARNING**
Select installation locations that can properly support the weight of the indoor and outdoor units. Install the units securely so that they do not topple or fall.
- CAUTION**
Do not install where there is the danger of combustible gas leakage.
Do not install the unit near heat source of heat, steam, or flammable gas.
If children under 10 years old may approach the unit, take preventive measures so that they cannot reach the unit.

INDOOR UNIT

- Install the indoor unit on a place having a sufficient strength so that it withstand against the weight of the indoor unit.
- The inlet and outlet ports should not be obstructed; the air should be able to blow all over the room.
- Leave the space required to service the air conditioner.
- Install the unit where the drain pipe can be easily installed.
- Providing as much space as possible between the indoor unit and the ceiling will make work much easier.
- If installing in a place where its humidity exceeds 80%, use heat insulation to prevent condensation.

Maintenance hole dimension

It shall be possible to install and remove the control box, fan units and filter.

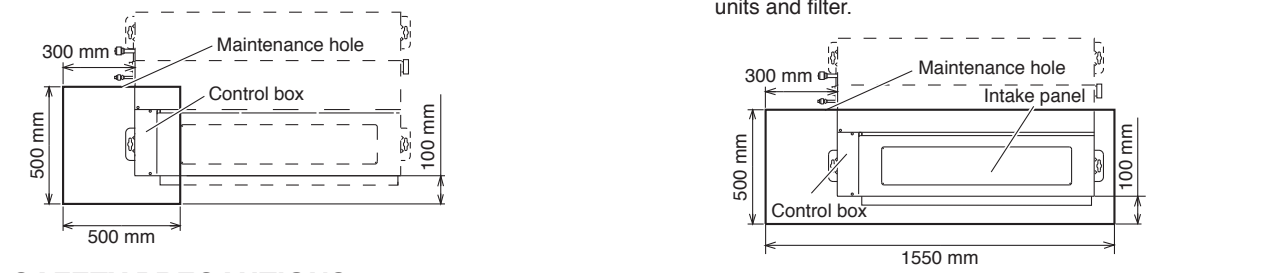

SAFETY PRECAUTIONS

- WARNING**
During installation, make sure that the refrigerant pipe is attached firmly before you run the compressor. Do not operate the compressor under the condition of refrigerant piping not attached properly with 2-way or 3-way valve open. This may cause abnormal pressure in the refrigeration cycle that leads to breakage and even injury.
- During the pump-down operation, make sure that the compressor is turned off before you remove the refrigerant piping. Do not remove the connection pipe while the compressor is in operation with 2-way or 3-way valve open. This may cause abnormal pressure in the refrigeration cycle that leads to breakage and even injury.
- When installing and relocating the air conditioner, do not mix gases other than the specified refrigerant (R410A) to enter the refrigerant cycle. If air or other gas enters the refrigerant cycle, the pressure inside the cycle will rise to an abnormally high value and cause breakage, injury, etc.
- If refrigerant leaks while work is being carried out, ventilate the area. If the refrigerant comes in contact with a flame, it produces a toxic gas.
- Do not turn on the power until all installation work is complete.

OUTDOOR UNIT

- WARNING**
Install the unit where it will not be tilted by more than 3°. However, do not install the unit with it tilted towards the side containing the compressor.
- When installing the outdoor unit where it may be exposed to strong wind, fasten it securely.

- Install the outdoor unit in a location which can withstand the weight of the unit and vibration, and which can install horizontally.
- Provide the indicated space to ensure good airflow.
- If possible, do not install the unit where it will be exposed to direct sunlight. (If necessary, install a blind that does not interfere with the airflow.)
- Do not install the unit near a source of heat, steam, or flammable gas.
- During heating operation, drain water flows from the outdoor unit. Therefore, install the outdoor unit in a place where the drain water flow will not be obstructed. (Reverse cycle model only)
- Do not install the unit where strong wind blows or where it is very dusty.
- Do not install the unit where people pass.
- Install the outdoor unit in a place where it will be free from being dirty or getting wet by rain as much as possible.
- Install the unit where connection to the indoor unit is easy.

- When there are obstacles at the back side.
- When there are obstacles at the back and front sides.

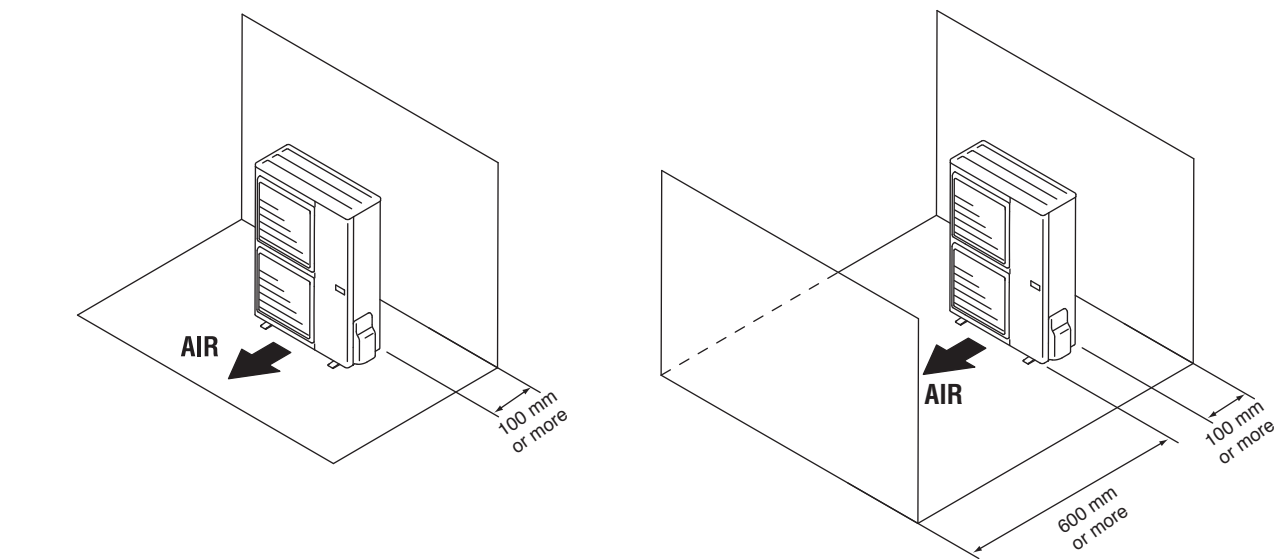

- When there are obstacles at the back, side(s), and top.
- When there are obstacles at the back side with the installation of more than one unit.

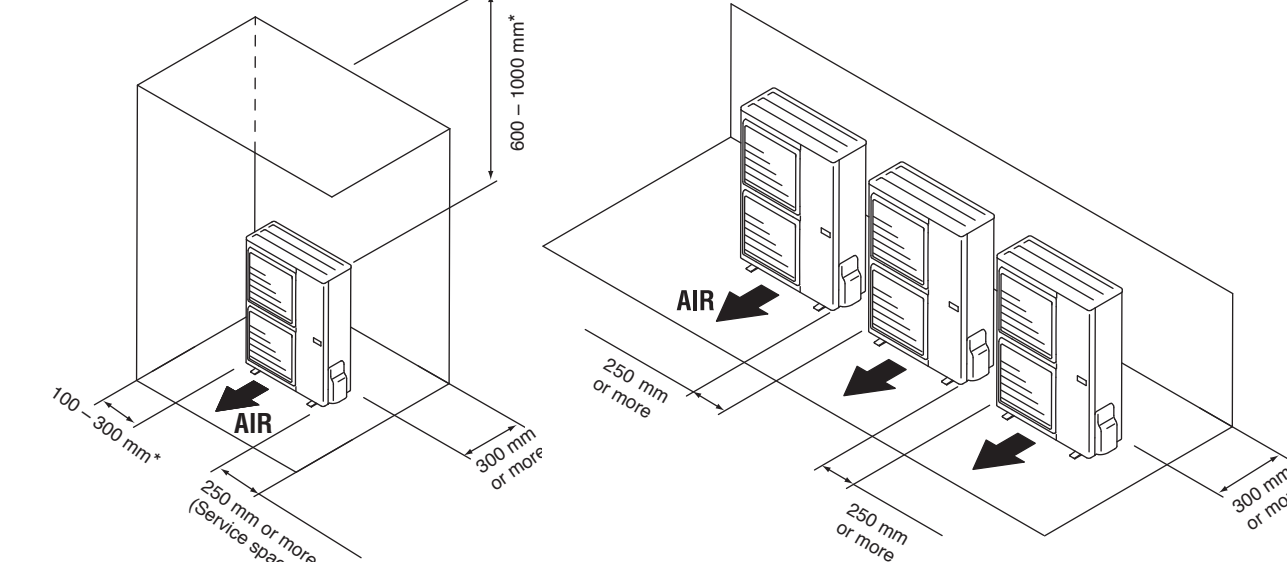

* If the space is larger than that is stated, the condition will be the same as that there are no obstacles.

INSTALLATION PROCEDURE

Install the air conditioner as follows:

1 INDOOR UNIT INSTALLATION

RECOMMENDED RANGE OF EXTERNAL STATIC PRESSURE

30Pa-150Pa

WARNING

- Install the air conditioner in a location which can withstand a load of at least five times the weight of the main unit and which will not amplify sound or vibration. If the installation location is not strong enough, the indoor unit may fall and cause injuries.
- If the job is done with the panel frame only, there is a risk that the unit will come loose. Please take care.

CAUTION

For installation, refer to the technical data.

1. INSTALLING THE HANGERS

WARNING

When fastening the hangers, make the bolt positions uniform.

Hanging bolt installation diagram.

(Example)

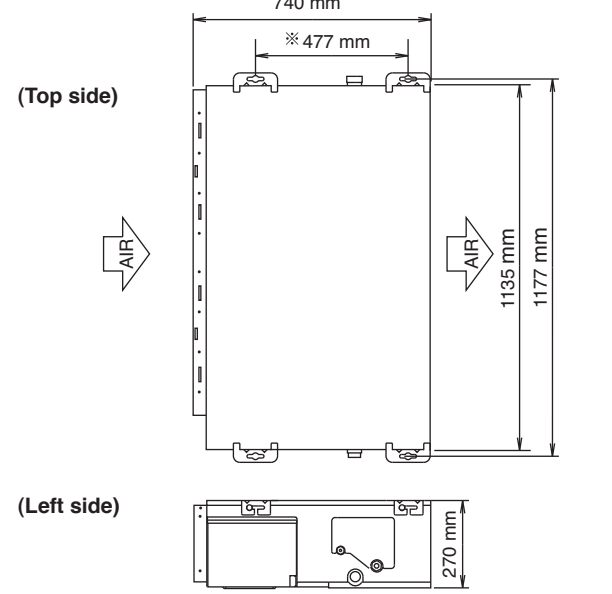

The distance of ※ is adjustable according to the place of the hanging bolts. (MAX.: 550 mm, MIN.: 410 mm)

CAUTION

- If an intake duct is installed, take care not to damage the temperature sensor (the temperature sensor is attached to the intake port flange).
- Be sure to install the air inlet grille and the air outlet grille for air circulation. The correct temperature cannot be detected.
- Grills must be fixed so that man cannot touch indoor unit fan, and cannot be removed by only hand operation without tool.
- Be sure to install the air filter in the air inlet. If the air filter is not installed, the heat exchanger may be clogged and its performance may decrease.

5. OUTLET DUCT CONNECTION

Duct installation pattern (CUT PART)

- Square duct
- Round duct outlet ×4 (This is the factory setting.)

When using as a square duct

- Cut the slit seam with a cutter.
- Turn up the insulation around the points to be cut according to the outlet port shape working points so that the insulation does not stick out at the cut part.
- Cut with nippers and remove the sheet metal.

Slide the unit in the arrow direction and fasten it.

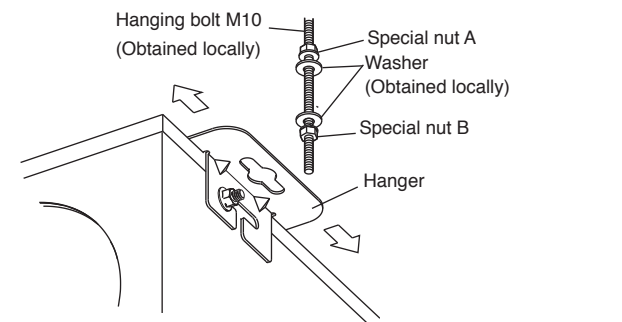

Bolt Strength 9.81 to 14.71 N·m (100 to 150 kgf·cm)

WARNING

Fasten the unit securely with special nuts A and B.

2. LEVELING

Base vertical direction leveling on the unit (right and left).

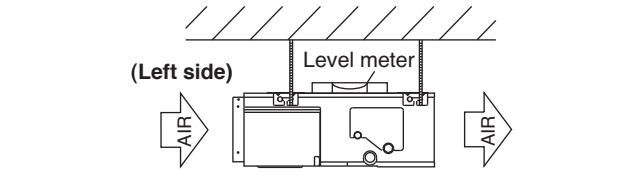

Base horizontal direction leveling on top of the unit.

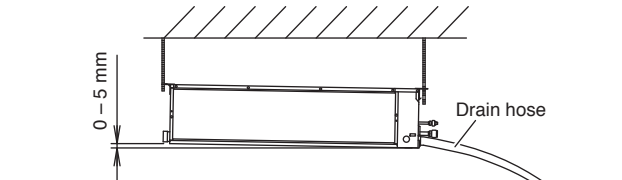

Give a slight tilt to the side to which the drain hose is connected. The tilt should be in the range of 0 mm to 5 mm.

3. INSTALLING DRAIN HOSE

Install the drain hose according to the measurements given in the following figure.

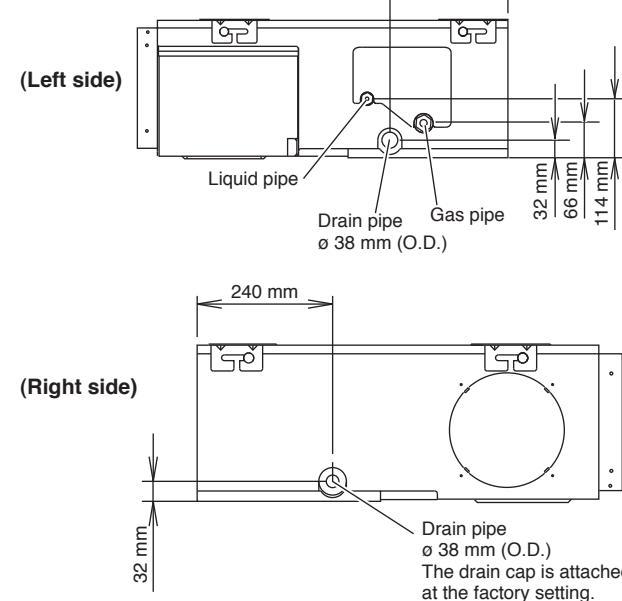

CAUTION

Install the drain hose in accordance with the instructions in this installation instruction sheet and keep the area warm enough to prevent condensation. Problems with the piping may lead to water leaks.

NOTE: INSTALL THE DRAIN HOSE

- Install the drain hose with downward gradient (1/50 to 1/100) and so there are no rises or traps in the hose.
- Use general hard polyvinyl chloride pipe (VP25) [outside diameter 38 mm] and connect it with adhesive (polyvinyl chloride) so that there is no leakage.
- When the hose is long, install supporters.
- Do not perform air bleeding.
- Always heat insulate the indoor side of the drain hose.

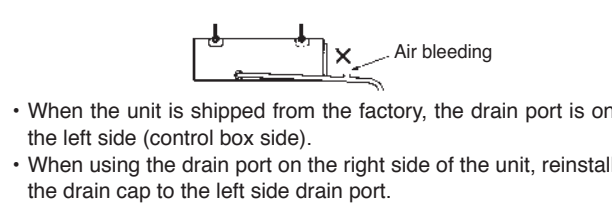
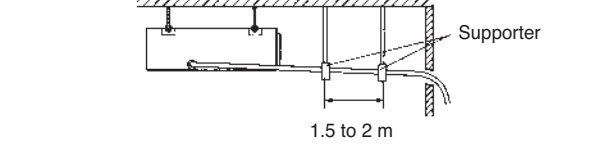
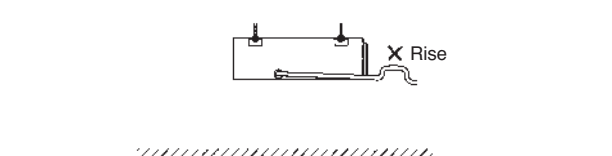
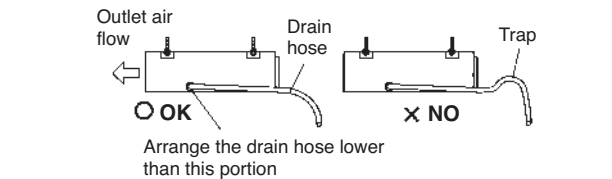

When the unit is shipped from the factory, the drain port is on the left side (control box side). When using the drain port on the right side of the unit, reinstall the drain cap with the left side drain port.

CAUTION

Always check that the drain cap is installed to the unused drain port and is fastened with the nylon fastener. If the drain cap is not installed, or is not sufficiently fastened by the nylon fastener, water may drip during the cooling operation.

CAUTION

When air is taken in from the bottom side, the operating sound of the product will easily enter the room. Install the product and intake grilles where the affect of the operating sound is small.

2 OUTDOOR UNIT INSTALLATION

1. OUTDOOR UNIT PROCESSING

- Outdoor unit to be fastened with bolts at the four places indicated by the arrows without fail.

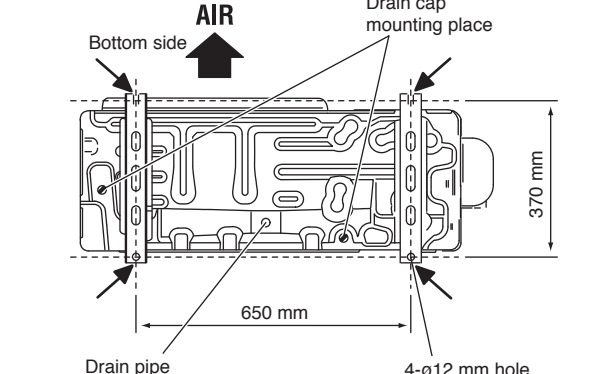

- Fix securely with bolts on a solid block. (Use 4 sets of commercially available M10 bolt, nut and washer.)

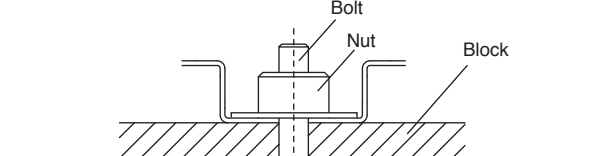

- Since the drain water flows out of the outdoor unit during heating operation, install the drain pipe and connect it to a commercial 16 mm hose. (Reverse cycle model only)

- When installing the drain pipe, plug all the holes other than the drain pipe mounting hole in the bottom of the outdoor unit with putty so there is no water leakage. (Reverse cycle model only)

When the outdoor temperature is 0 °C or less, do not use the accessory drain pipe and drain cap. If the drain pipe and drain cap are used, the drain water in the pipe may freeze in extremely cold weather. (Reverse cycle model only)

CAUTION

When the outdoor temperature is 0 °C or less, do not use the accessory drain pipe and drain cap. If the drain pipe and drain cap are used, the drain water in the pipe may freeze in extremely cold weather. (Reverse cycle model only)

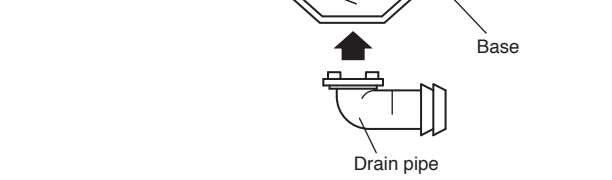

- Cut the drain hose insulation at a position approximately 80 mm from the end with cutters, etc.
- Stick the large drain hose insulation at the drain hose installation side.
- Stick the small drain hose insulation at the drain cap side.

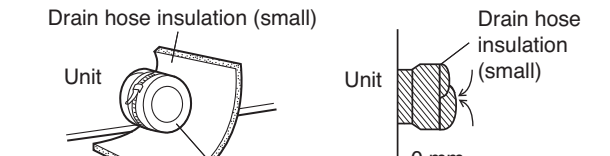
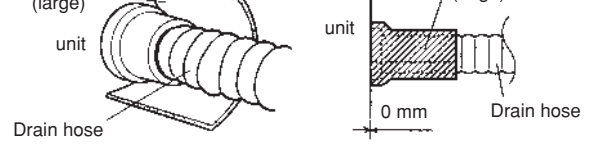
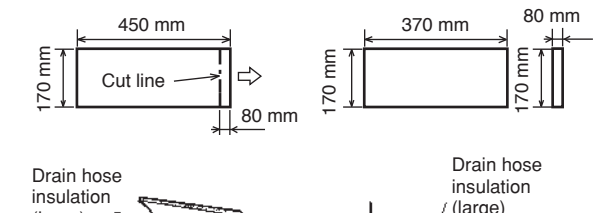

Cover the drain cap with the drain hose insulation.

4. INTAKE DUCT CONNECTION

Follow the procedure in the following figure to the ducts.

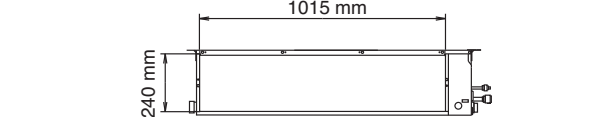

The air inlet duct can be changed by replacing the intake grille and flange.

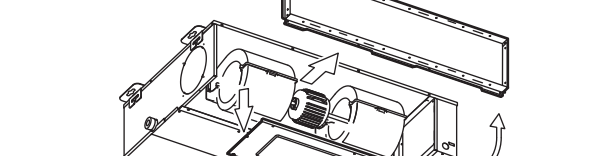

For the bottom air intake, follow the procedure of ① → ② for installation. (The factory setting is back air intake.)

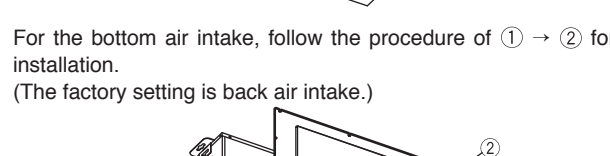

For the bottom air intake, follow the procedure of ① → ② for installation. (The factory setting is back air intake.)



CAUTION

When air is taken in from the bottom side, the operating sound of the product will easily enter the room. Install the product and intake grilles where the affect of the operating sound is small.

3 CONNECTING THE PIPE

CAUTION

- Do not use mineral oil on flared part. Prevent mineral oil from getting into the system as this would reduce the lifetime of the units.
- While welding the pipes, be sure to blow dry nitrogen gas through them.
- The maximum lengths of this product are shown in the table. If the units are further apart than this, correct operation cannot be guaranteed.

1. FLARING

- Cut the connection pipe to the necessary length with a pipe cutter. (2) Hold the pipe downward so that cuttings will not enter the pipe and remove the burrs.
- Insert the flare nut (always use the flare nut attached to the indoor and outdoor units respectively) onto the pipe and perform the flare processing with a flare tool. Use the special R410A flare tool, or the conventional (for R22) flare tool.

Check if [L] is flared uniformly and is not cracked or scratched.

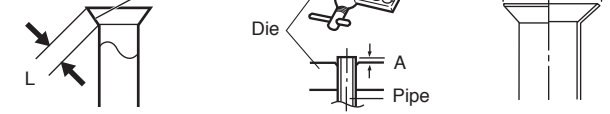

Pipe outside diameter	Dimension A (mm)	
	Flare tool for R410A, clutch type	
6.35 mm (1/4 in.)		0 to 0.5
9.52 mm (3/8 in.)		
12.70 mm (1/2 in.)		
15.88 mm (5/8 in.)		
19.05 mm (3/4 in.)		

Pipe outside diameter	Dimension B (mm)	
	φ _{0.4}	
6.35 mm (1/4 in.)	9.1	
9.52 mm (3/8 in.)	13.2	
12.70 mm (1/2 in.)	16.6	
15.88 mm (5/8 in.)	19.7	
19.05 mm (3/4 in.)	24.0	

When using conventional flare tools to flare R410A pipes, the dimension A should be approximately 0.5 mm more than indicated in the table (for flaring with R410A flare tools) to achieve the specified flaring. Use a thickness gauge to measure the dimension A.

Pipe outside diameter	Width across flats	
	Pipe outside diameter	Width across flats of Flare nut
6.35 mm (1/4 in.)		1

3 CONNECTING THE PIPE

2. BENDING PIPES
The pipes are shaped by your hands. Be careful not to collapse them. Do not bend the pipes in an angle more than 90°. When pipes are repeatedly bent or stretched, the material will harden, making it difficult to bend or stretch them any more. Do not bend or stretch the pipes more than three times.

- CAUTION**
- To prevent breaking of the pipe, avoid sharp bends. Bend the pipe with a radius of curvature of 150 mm or over.
 - If the pipe is bent repeatedly at the same place, it will break.

3. CONNECTION PIPES

- Indoor unit**
- (1) Detach the caps and plugs from the pipes.
- CAUTION**
- Be sure to apply the pipe against the port on the indoor unit correctly. If the centering is improper, the flare nut cannot be tightened smoothly. If the flare nut is forced to turn, the threads will be damaged.
 - Do not remove the flare nut from the indoor unit pipe until immediately before connecting the connection pipe.

- (2) Centering the pipe against port on the indoor unit, turn the flare nut with your hand.

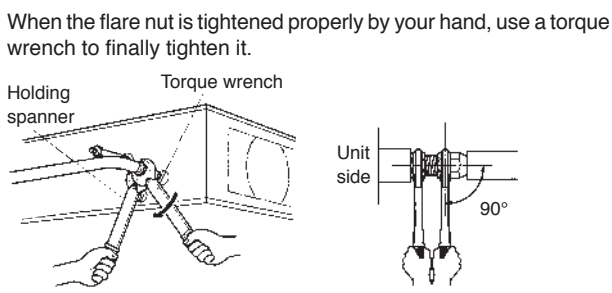

- CAUTION**
- Hold the torque wrench at its grip, keeping it in the right angle with the pipe, in order to tighten the flare nut correctly.

Flare nut	Tightening torque
6.35 mm (1/4 in.) dia.	16 to 18 N·m (160 to 180 kgf·cm)
9.52 mm (3/8 in.) dia.	30 to 42 N·m (300 to 420 kgf·cm)
12.70 mm (1/2 in.) dia.	49 to 61 N·m (490 to 610 kgf·cm)
15.88 mm (5/8 in.) dia.	63 to 75 N·m (630 to 750 kgf·cm)
19.05 mm (3/4 in.) dia.	90 to 110 N·m (900 to 1100 kgf·cm)

Outdoor unit

Tighten the flare nut of the connection pipe at the outdoor unit valve connector. The tightening method is the same as that at the indoor side.

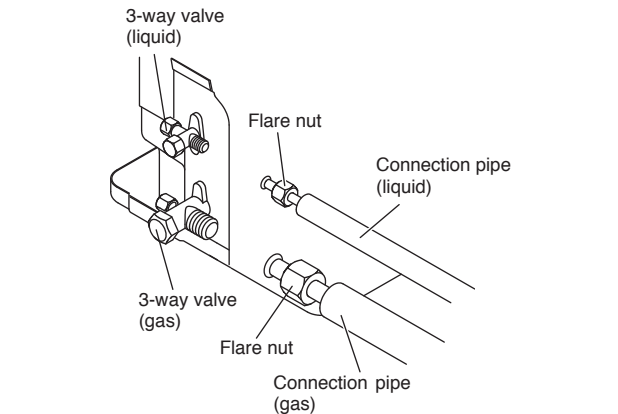

4. VACUUM

- Remove the cap, and connect the gauge manifold and the vacuum pump to the charging valve by the service hoses.
- Vacuum the indoor unit and the connecting pipes until the pressure gauge indicates -0.1 MPa (-76 cmHg).
- When -0.1 MPa (-76 cmHg) is reached, operate the vacuum pump for at least 60 minutes.
- Disconnect the service hoses and fit the cap to the charging valve to the specified torque.
- Remove the blank caps, and fully open the spindles of the 2-way and 3-way valves with a hexagon wrench [Torque: 6-7 N·m (60 to 70 kgf·cm)].
- Tighten the blank caps of the 2-way valve and 3-way valve to the specified torque.

Pipe outside diameter	Tightening torque
Blank cap	
6.35 mm (1/4 in.)	20 to 25 N·m (200 to 250 kgf·cm)
9.52 mm (3/8 in.)	20 to 25 N·m (200 to 250 kgf·cm)
12.70 mm (1/2 in.)	28 to 32 N·m (280 to 320 kgf·cm)
15.88 mm (5/8 in.)	30 to 35 N·m (300 to 350 kgf·cm)
19.05 mm (3/4 in.)	35 to 40 N·m (350 to 400 kgf·cm)
Charging port cap	12.5 to 16 N·m (125 to 160 kgf·cm)

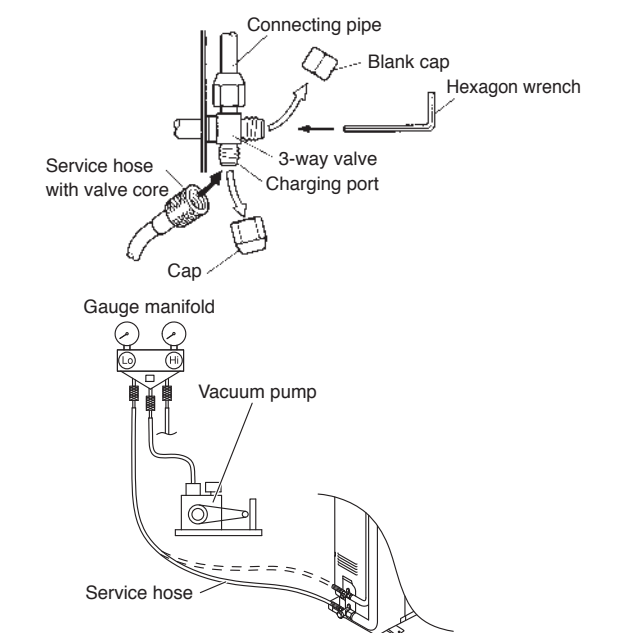

[36,000 BTU/h class (1 phase TYPE)]

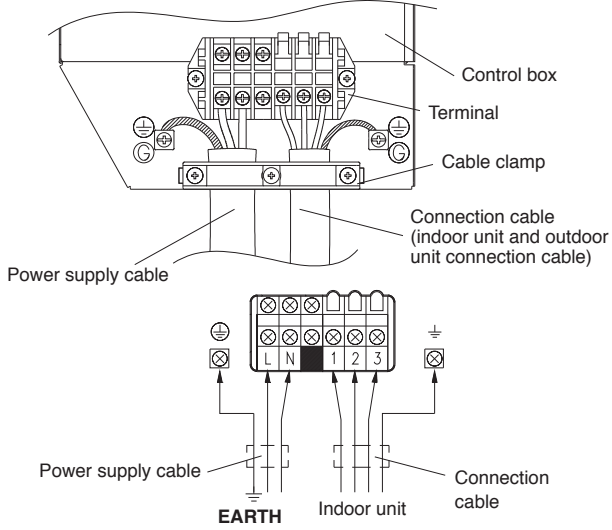

- (5) Power supply cable and connection cable should be fixed with cable clip as shown in the figure. Fill in a gap at the entrance of the cables with insulation (seal).

[45,000 BTU/h class] [36,000 BTU/h class (Reverse cycle model)]

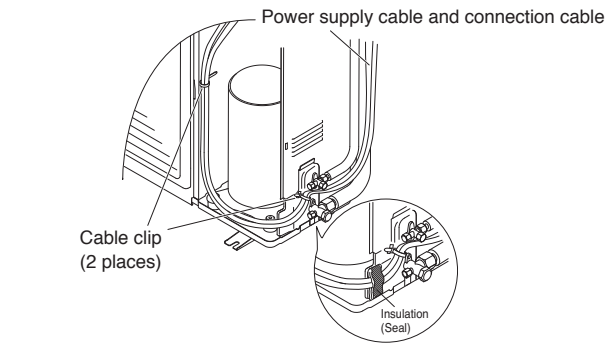

[36,000 BTU/h class (Cooling model)]

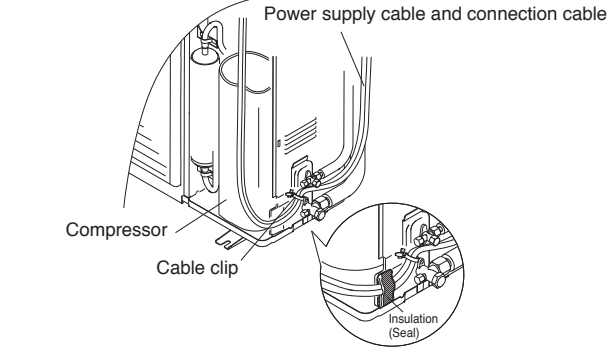

- CAUTION**
- Do not make power supply cable and connection cable come in contact with valve (Gas).
-

- (6) Put the service cover and valve cover back after completion of the work.

6 REMOTE CONTROLLER SETTING

- CAUTION**
- When detecting the room temperature using the remote controller, please set up the remote controller according to the following conditions. If the remote controller is not well set, the correct room temperature will not be detected, and thus the abnormal conditions like "not cooled" or "not heated" will occur even if the air-conditioner is running normally.
 - A location with an average temperature for the room being airconditioned.
 - Not directly exposed to the outlet air from the air-conditioner.
 - Out of direct sunlight.
 - Away from the influence of other heat sources.
 - When installing the remote controller and cable near a source of electromagnetic waves, separate the remote controller from the source of the electromagnetic waves and use shielded cable.
 - Do not touch the remote controller PC board and PC board parts directly with your hands.

1. INSTALLING THE REMOTE CONTROLLER

- (1) Open the operation panel on the front of the remote controller, remove the two screws indicated in the following figure, and then remove the front case of the remote controller.
-
- (2) Install the rear case to the wall, etc. with the two tapping screws. Refer to the following information to install the remote controller wires.
-

- When installing the remote controller, remove the connector from the front case. The wires may break if the connector is not removed and the front case hangs down. When installing the front case, connect the connector to the front case.
-
- Install the remote controller wires so as not to be directly touched with your hand.

CAUTION

- Do not purge the air refrigerants but use a vacuum pump to vacuum the installation! There is no extra refrigerant in the outdoor unit for air purging!
- Use a vacuum pump and gauge manifold and charging hose for R410A exclusively. Using the same vacuum for different refrigerants may damage the vacuum pump or the unit.

5. ADDITIONAL CHARGE

Refrigerant suitable for a piping length of 20 m is charged in the outdoor unit at the factory. When the piping is longer than 20 m, additional charging is necessary. For the additional amount, see the table below.

Model type	Pipe length	20 m (66 ft)	30 m (99 ft)	40 m (132 ft)	50 m (164 ft)	g/m (oz/ft)
36,000 BTU/h class	None	300g (10.6 oz)	600g (21.2 oz)	900g (31.8 oz)	30 g/m (1.06 oz)	(3.3 ft)
	None	400g (14.1 oz)	800g (28.2 oz)	1200g (42.3 oz)	40 g/m (1.41 oz)	(3.3 ft)
45,000 BTU/h class	None	400g (14.1 oz)	800g (28.2 oz)	1200g (42.3 oz)	40 g/m (1.41 oz)	(3.3 ft)
	None	400g (14.1 oz)	800g (28.2 oz)	1200g (42.3 oz)	40 g/m (1.41 oz)	(3.3 ft)

CAUTION

- When moving and installing the air conditioner, do not mix gas other than the specified refrigerant (R410A) inside the refrigerant cycle.
- When charging the refrigerant R410A, always use an electronic balance for refrigerant charging (to measure the refrigerant by weight).
- When charging the refrigerant, take into account the slight change in the composition of the gas and liquid phases, and always charge from the liquid phase side whose composition is stable.
- Add refrigerant from the charging valve after the completion of the work.
- The maximum length of piping is 50 m. If the units are further apart than this, correct operation can not be guaranteed.

6. GAS LEAKAGE INSPECTION

- CAUTION**
- After connecting the piping, check the all joints for gas leakage with gas leak detector.
 - When inspecting gas leakage, always use the vacuum pump for pressure. Do not use nitrogen gas.

2. ROUTING THE REMOTE CONTROLLER WIRES

- Install the remote controller wires to the terminals on the top of the rear case as shown in the following figure.
- Fasten the wires with the binder.

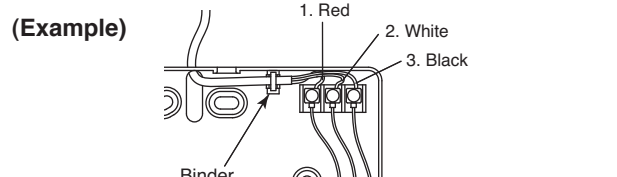

3. SETTING THE DIP SWITCHES

- When using a battery (memory backup)
-
- Change the DIP switch setting to use batteries. (The DIP switch is not set to use batteries at the factory.) Change DIP switch No. 6 from OFF to ON. If batteries are not used, all of the settings stored in memory will be deleted if there is a power failure.

4. SETTING THE ROOM TEMPERATURE DETECTION LOCATION

- The detection location of the room temperature can be selected from the following three examples. Choose the detection location that is best for the installation location.
- A. Indoor unit setting (factory setting)**
- The room temperature is detected by the indoor unit temperature sensor.
-
- (1) When the THERMO SENSOR button is pressed, the lock display flashes because the function is locked at the factory.
- B. Remote controller setting**
- The room temperature is detected by the remote controller temperature sensor.
-

7. HEAT INSULATION ON THE PIPE JOINTS (INDOOR SIDE ONLY)

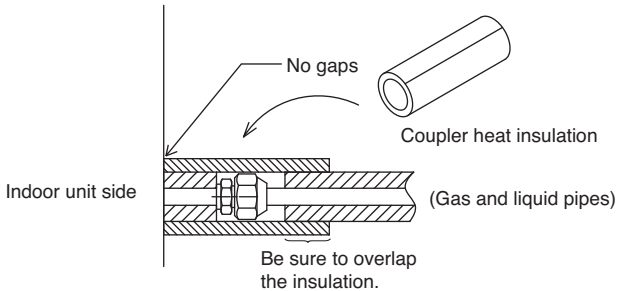

- CAUTION**
- There should be no gaps between the insulation and the product.

4 POWER

CAUTION

- [45,000 BTU/h class (3 phase TYPE)] [36,000 BTU/h class (3 phase TYPE)] The rated voltage of this product is 400 V 3N ~ 50 Hz. Before turning on, verify that the voltage is within the 342 V to 457 V range. [36,000 BTU/h class (1 phase TYPE)] The rated voltage of this product is 230 V ~ 50 Hz. Before turning on, verify that the voltage is within the 198 V to 264 V range.
- Always use a special branch circuit and install a special receptacle to supply power to the air conditioner.
- Use a special branch circuit breaker and receptacle matched to the capacity of the air conditioner. (Install in accordance with standard.)
- Perform wiring work in accordance with standards so that the air conditioner can be operated safely and positively.
- Install a leakage special branch circuit breaker in accordance with the related laws and regulations and electric company standards.

CAUTION

- The power source capacity must be the sum of the air conditioner current and the current of other electrical appliances. When the current contracted capacity is insufficient, change the contracted capacity.
- When the voltage is low and the air conditioner is difficult to start, contact the power company the voltage raised.
- This air conditioner must be connected to a power source that has an electrical impedance of 0.11 Ω or less or has a supply current of 100 A or greater. If the power supply does not meet the specifications, contact the power company.

5 ELECTRICAL WIRING

WARNING

- Before starting work, check that power is not being supplied to the indoor unit and outdoor unit.
- Match the terminal board numbers and connection cable colors with those of the outdoor unit. Erroneous wiring may cause burning of the electric parts.
- Connect the connection cables firmly to the terminal board. Imperfect installation may cause a fire.
- Always fasten the outside covering of the connection cable with the cable clamp. (If the insulator is chafed, electric leakage may occur.)
- Always connect the ground wire.

HOW TO CONNECT WIRING TO THE TERMINALS

- A. For solid core wiring (or F-cable)**
- Cut the wire end with a wire cutter or wire-cutting pliers, then strip the insulation to about 25 mm to expose the solid wire.
 - Using a screwdriver, remove the terminal screw(s) on the terminal board.
 - Using pliers, bend the solid wire to form a loop suitable for the terminal screw.
 - Shape the loop wire properly, place it on the terminal board and tighten securely with the terminal screw using a screwdriver.
- B. For strand wiring**
- Cut the wire end with a wire cutter or wire-cutting pliers, then strip the insulation to about 10 mm to expose the strand wiring.
 - Using a screwdriver, remove the terminal screw(s) on the terminal board.
 - Using a round terminal fastener or pliers, securely clamp a round terminal to each stripped wire end.
 - Position the round terminal wire, and replace and tighten the terminal screw using a screwdriver.
-

CAUTION

- Do not bundle the remote controller cable, or wire the remote controller cable in parallel, with the indoor unit connection wire (to the outdoor unit) and the power supply cable. It may cause erroneous operation.

7 TEST RUN

- CAUTION**
- Supply power to the crankcase heater for at least 12 hours before the start of operation in winter.

- Stop the air conditioner operation.
- Press the MODE button and the FAN button simultaneously for 2 seconds or more to start the test run.
- Press the START/STOP button to stop the test run.

[SELF-DIAGNOSIS]

When the error indication "E:EE" is displayed, follow the following items to perform the self-diagnosis. "E:EE" indicates an error has occurred.

- REMOTE CONTROLLER DISPLAY
- OUTDOOR UNIT LEADS

Error code	Error contents
0C	Discharge pipe temperature sensor or compressor temperature sensor open
0d	Discharge pipe temperature sensor or compressor temperature sensor short-circuited
0E	Outdoor high pressure error
0F	Discharge pipe temperature or compressor temperature error
11	Model error
12	Indoor fan error
13	Outdoor signal error
14	Outdoor EEPROM error
00	Communication error (indoor unit ↔ remote controller)
01	Communication error (indoor unit ↔ outdoor unit)
02	Room temperature sensor open
03	Room temperature sensor short-circuited
04	Indoor heat exchanger temperature sensor open
05	Indoor heat exchanger temperature sensor short-circuited
06	Outdoor heat exchanger temperature sensor open
07	Outdoor heat exchanger temperature sensor short-circuited
08	Power source connection error
09	Float switch operated
0A	Outdoor temperature sensor open
0b	Outdoor temperature sensor short-circuited

1. CONNECTION DIAGRAMS

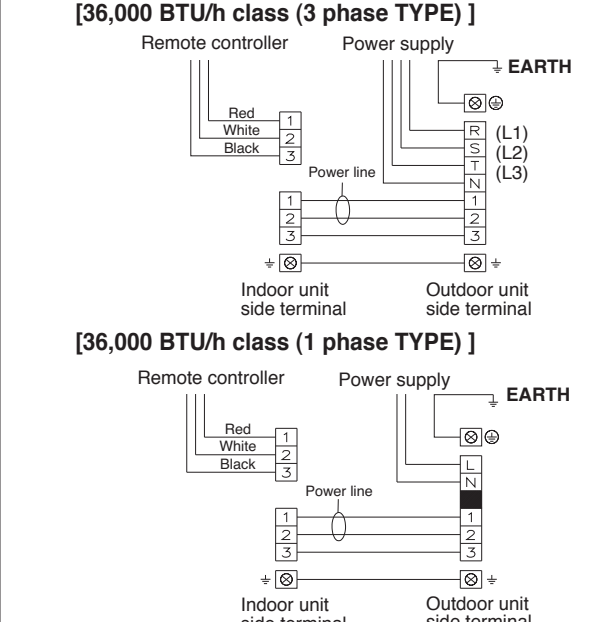

2. CONNECTION CABLE PREPARATION

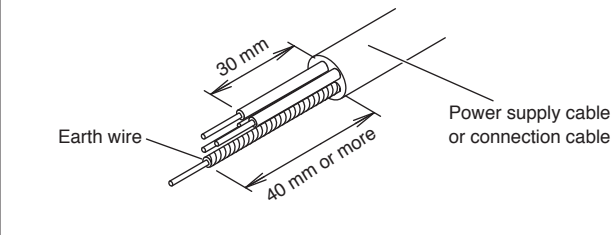

3. INDOOR UNIT

- CAUTION**
- Use care not to mistake the power supply cable and connection wires when installing.
 - Install so that the wires for the remote controller will not come in contact with other connection wires.
 - If there is a risk of entering insects and small animals into the hole for cables, fill in the gap with putty.

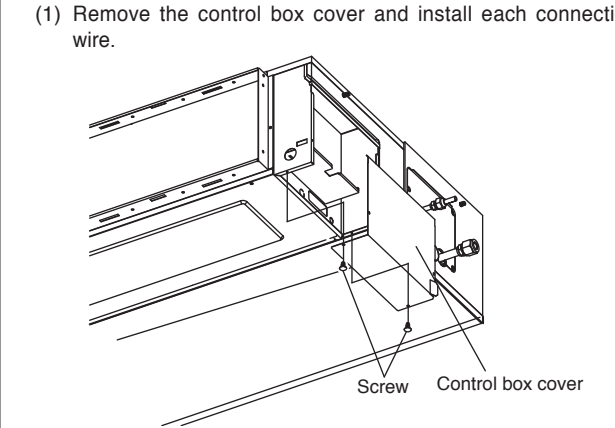

4. OUTDOOR UNIT

- CAUTION**
- When connecting the power supply cable, make sure that the phase of the power supply matches with the phase of the terminal board. If the phases do not match, the compressor will rotate in reverse and will not be able to compress.

2. CONNECTION CABLE PREPARATION

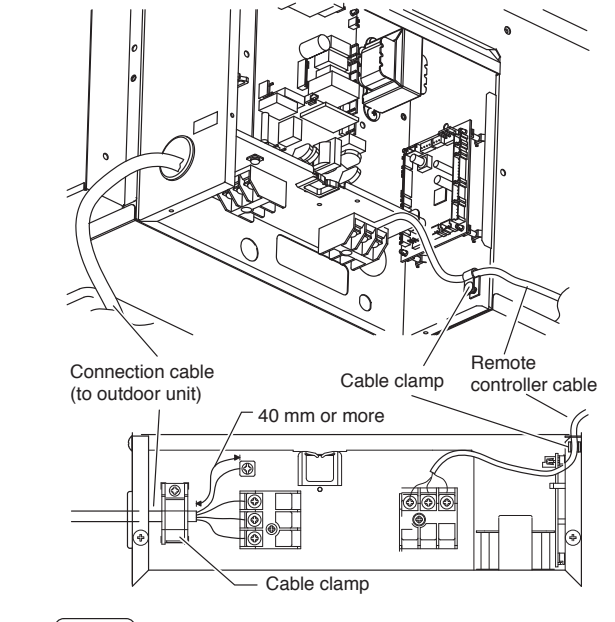

3. INDOOR UNIT

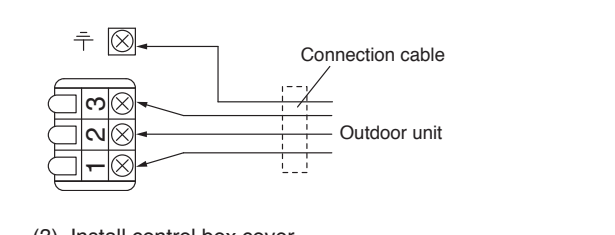

4. OUTDOOR UNIT

- CAUTION**
- When connecting the power supply cable, make sure that the phase of the power supply matches with the phase of the terminal board. If the phases do not match, the compressor will rotate in reverse and will not be able to compress.

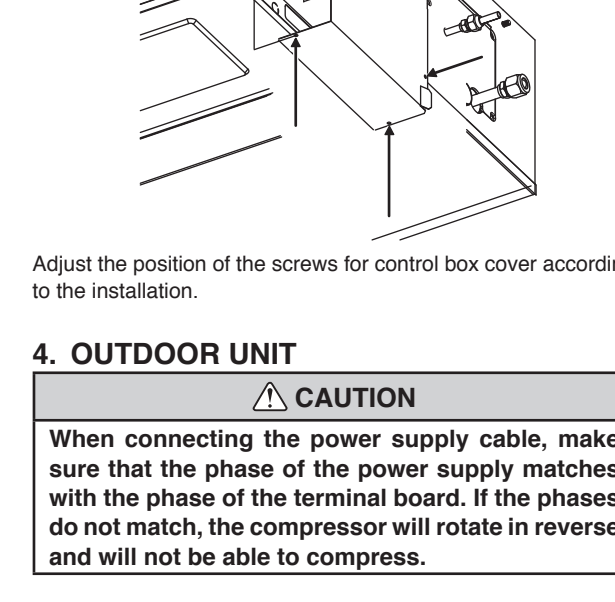

8 SPECIAL INSTALLATION METHODS

- CAUTION**
- When setting the rotary switch and DIP switches, do not touch any other parts on the circuit board directly with your bare hands.
 - Be sure to turn off the main power.

1. GROUP CONTROL SYSTEM

A number of indoor units can be operated at the same time using a single remote controller.

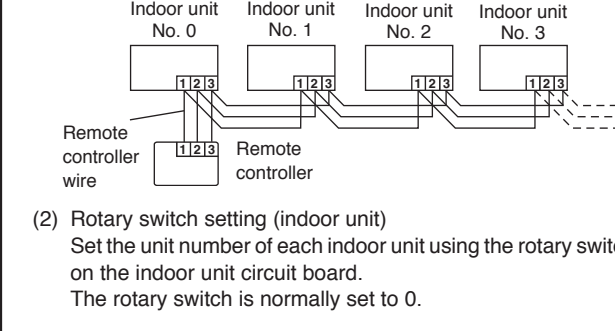

2. DUAL REMOTE CONTROLLERS (OPTIONAL)

Two separate remote controllers can be used to operate the indoor units.

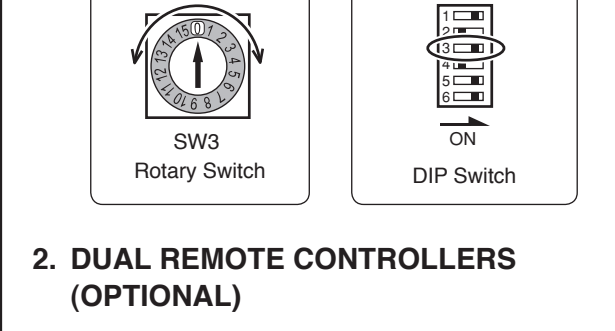

[DIP-SWITCH SETTING]

NO.	SW state		Detail
	OFF	ON	
1	*	*	Remote sensor setting
2	Edge *	Pulse	Control input setting
3	Validity *	Invalidity	Auto restart setting

1. SERVICE COVER REMOVAL

- Service cover removal
 - Remove the two mounting screws.
 - Remove the service cover by pushing downwards.

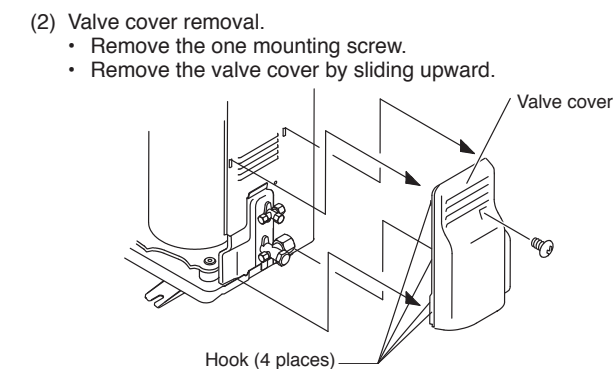

2. VALVE COVER REMOVAL

- Valve cover removal
 - Remove the one mounting screw.
 - Remove the valve cover by sliding upward.

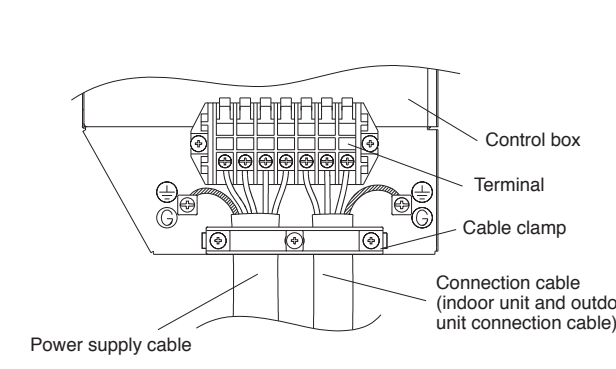

3. CANCELING AUTO RESTART

The auto restart function can be canceled.

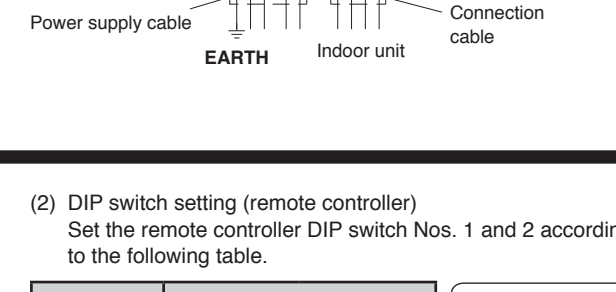

4. REMOTE CONTROLLER

Number of remote controllers	Master unit		Remote controller
	DIP-SW No. 1	DIP-SW No. 2	
1 (Normal)	ON	OFF	
2 (Dual)	OFF	OFF	

5. INDOOR UNIT

Number of remote controllers	Slave unit	
	DIP-SW No. 1	DIP-SW No. 2
1 (Normal)	-	-
2 (Dual)	ON	ON

6. REMOTE CONTROLLER

NO.	SW state		Detail
	OFF	ON	
1	*	*	Dual remote controller setting
2	Edge *	Pulse	Group control setting
3	Validity *	Invalidity	Auto restart setting

7. REMOTE CONTROLLER

NO.	SW state		Detail
	OFF	ON	
1	*	*	Dual remote controller setting
2	Edge *	Pulse	Group control setting
3	Validity *	Invalidity	Auto restart setting