

SPLIT TYPE
ROOM AIR CONDITIONER
WALL MOUNTED TYPE

SERVICE MANUAL



Indoor unit	Outdoor unit
ASYG07LUCA	AOYG07LUCA
ASYG09LUCA	AOYG09LUCB

CONTENTS

SPECIFICATIONS.....	1
DIMENSIONS.....	2
REFRIGERANT SYSTEM DIAGRAM... .	3
CIRCUIT DIAGRAM.....	4
INDOOR PCB CIRCUIT DIAGRAM.....	5
OUTDOOR PCB CIRCUIT DIAGRAM... .	9
ERROR DETECTION.....	11
PARTS (INDOOR UNIT).....	13
PARTS (OUTDOOR UNIT).....	18
ACCESSORIES.....	22

SPECIFICATIONS

ELECTRICAL DATA

TYPE		Cool & heat inverter	
INDOOR UNIT		ASYG07LUCA	ASYG09LUCA
OUTDOOR UNIT		AOYG07LUCA	AOYG09LUCB
COOLING CAPACITY		2.00 kW	2.50 kW
HEATING CAPACITY		3.00 kW	3.20 kW
POWER SOURCE		230 V	230 V
FREQUENCY		50 Hz	50 Hz
RUNNING CURRENT	Cooling	2.6 A	3.1 A
	Heating	3.4 A	3.4 A
INPUT WATTS	Cooling	0.46 kW	0.555 kW
	Heating	0.74 kW	0.68 kW
E.E.R.	Cooling	4.35 kW/kW	4.50 kW/kW
COP	Heating	4.05 kW/kW	4.71 kW/kW
MOISTURE REMOVAL		1.0 L/h	1.3 L/h
AIR CIRCULATION HIGH	Cooling	680 m ³ /h	800 m ³ /h
	Heating	710 m ³ /h	800 m ³ /h
MAXIMUM CURRENT	Cooling	6.0 A	
	Heating	7.5 A	

FAN MOTOR

POWER SOURCE		230 V	
INDOOR UNIT Cooling	High	1,140 r.p.m.	1,300 r.p.m.
	Medium	1,050 r.p.m.	1,080 r.p.m.
	Low	930 r.p.m.	960 r.p.m.
	Quiet	650 r.p.m.	650 r.p.m.
INDOOR UNIT Heating	High	1,180 r.p.m.	1,300 r.p.m.
	Medium	1,050 r.p.m.	1,120 r.p.m.
	Low	930 r.p.m.	960 r.p.m.
	Quiet	650 r.p.m.	650 r.p.m.
OUTDOOR UNIT Cooling		730 r.p.m.	780 r.p.m.
OUTDOOR UNIT Heating		650 r.p.m.	720 r.p.m.

SOUND PRESSURE LEVEL

INDOOR UNIT Cooling	High	38 dB	42 dB
	Medium	35 dB	36 dB
	Low	31 dB	32 dB
	Quiet	21 dB	21 dB
INDOOR UNIT Heating	High	38 dB	42 dB
	Medium	35 dB	37 dB
	Low	31 dB	32 dB
	Quiet	21 dB	21 dB
OUTDOOR UNIT Cooling		46 dB	48 dB
OUTDOOR UNIT Heating		46 dB	48 dB

COMPRESSOR AND REFRIGERANT

COMPRESSOR TYPE		Hermetic type, 4 pole, Brushless motor, Rotary	
DISCRIMINATION		5SS072XHA01	
WEIGHT (with oil)		6.0 kg	
PRECHARGED REFRIGERANT		700 g	850 g
REFRIGERANT TYPE		R410A	R410A
FULL CHARGE	Pipe length 15 m	700 g	850 g
	20 m	800 g	950 g
ADDITIONAL REFRIGERANT		20 g/m	
MAXIMUM PIPING HEIGHT		15m	

DIMENSIONS

INDOOR UNIT	H x W x D	282 x 870 x 185 mm
OUTDOOR UNIT	H x W x D	540 x 660 x 290 mm

WEIGHT

INDOOR UNIT	Shipping / Net	12 kg / 9.5 kg
OUTDOOR UNIT	Shipping / Net	27 kg / 23 kg / 28 kg / 25 kg

DIMENSIONS

INDOOR UNIT

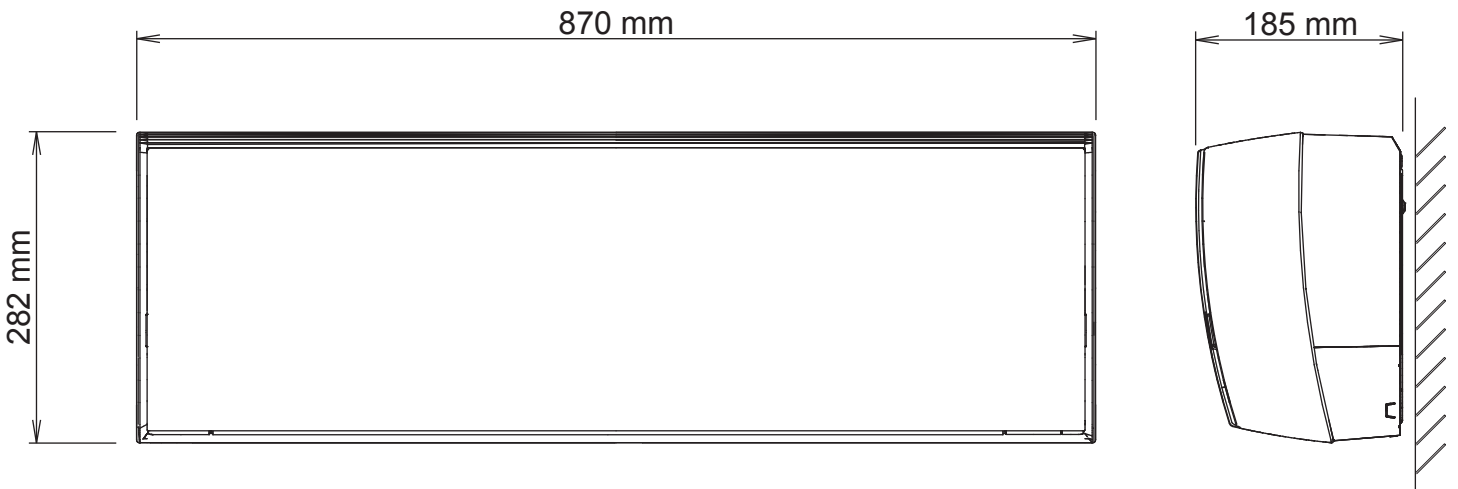

Drain hose

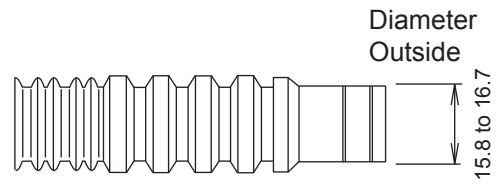
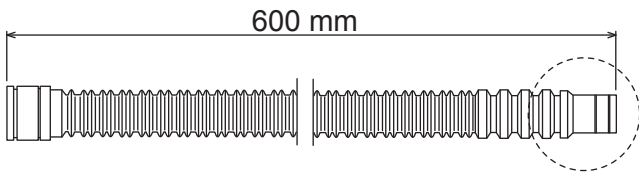

Inside : 13.8 mm

OUTDOOR UNIT

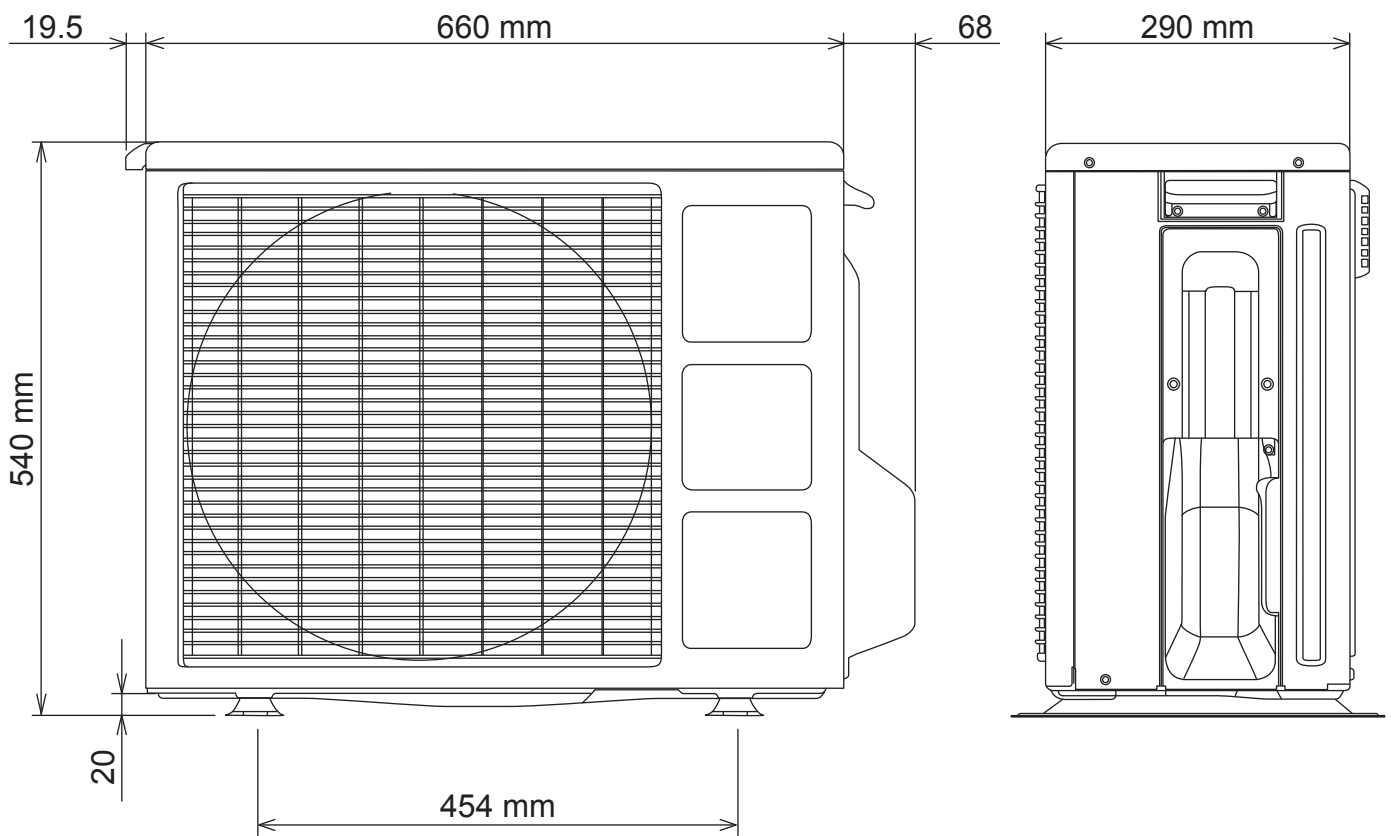

REFRIGERANT SYSTEM DIAGRAM

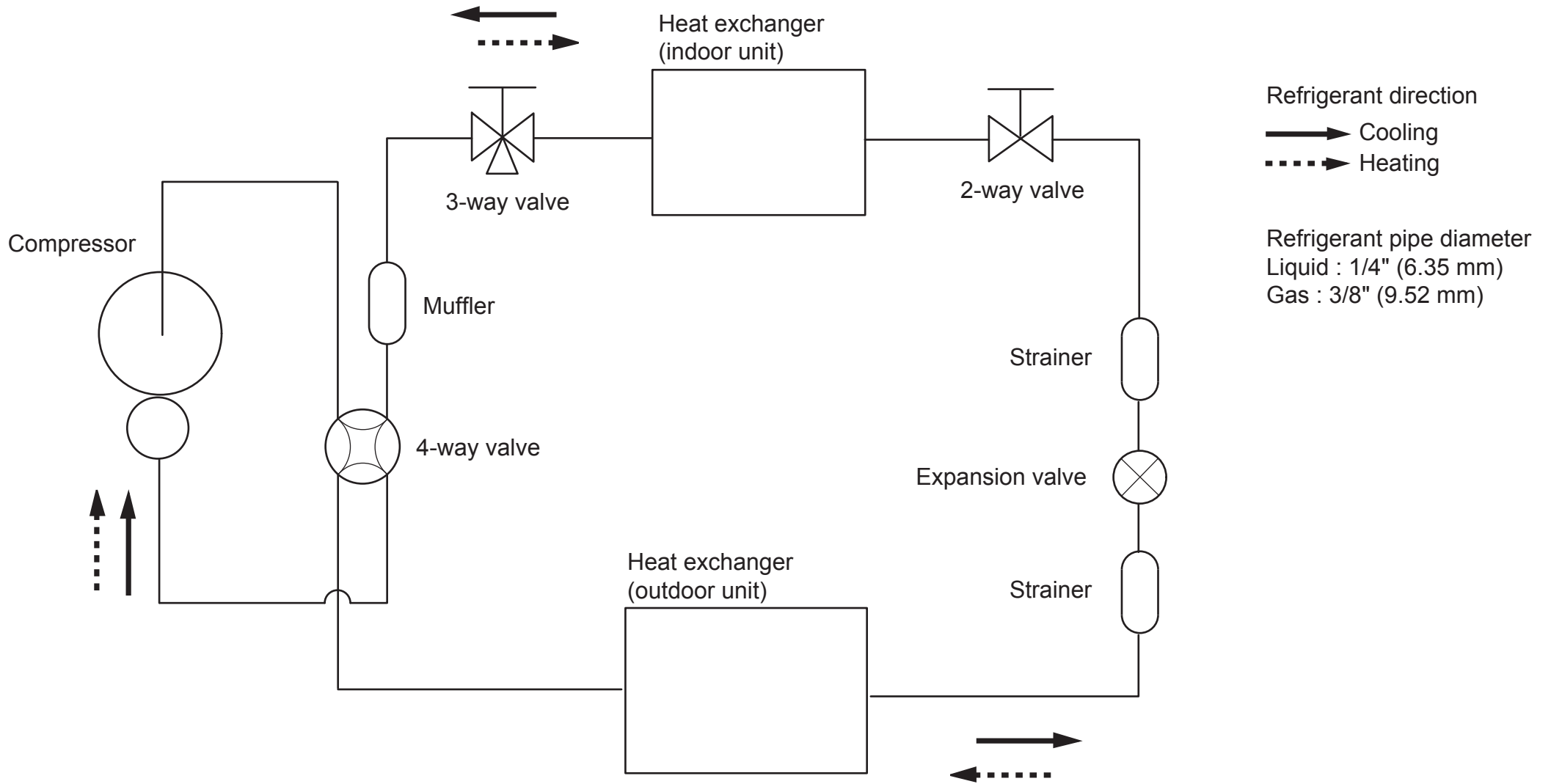

CIRCUIT DIAGRAM

INDOOR UNIT

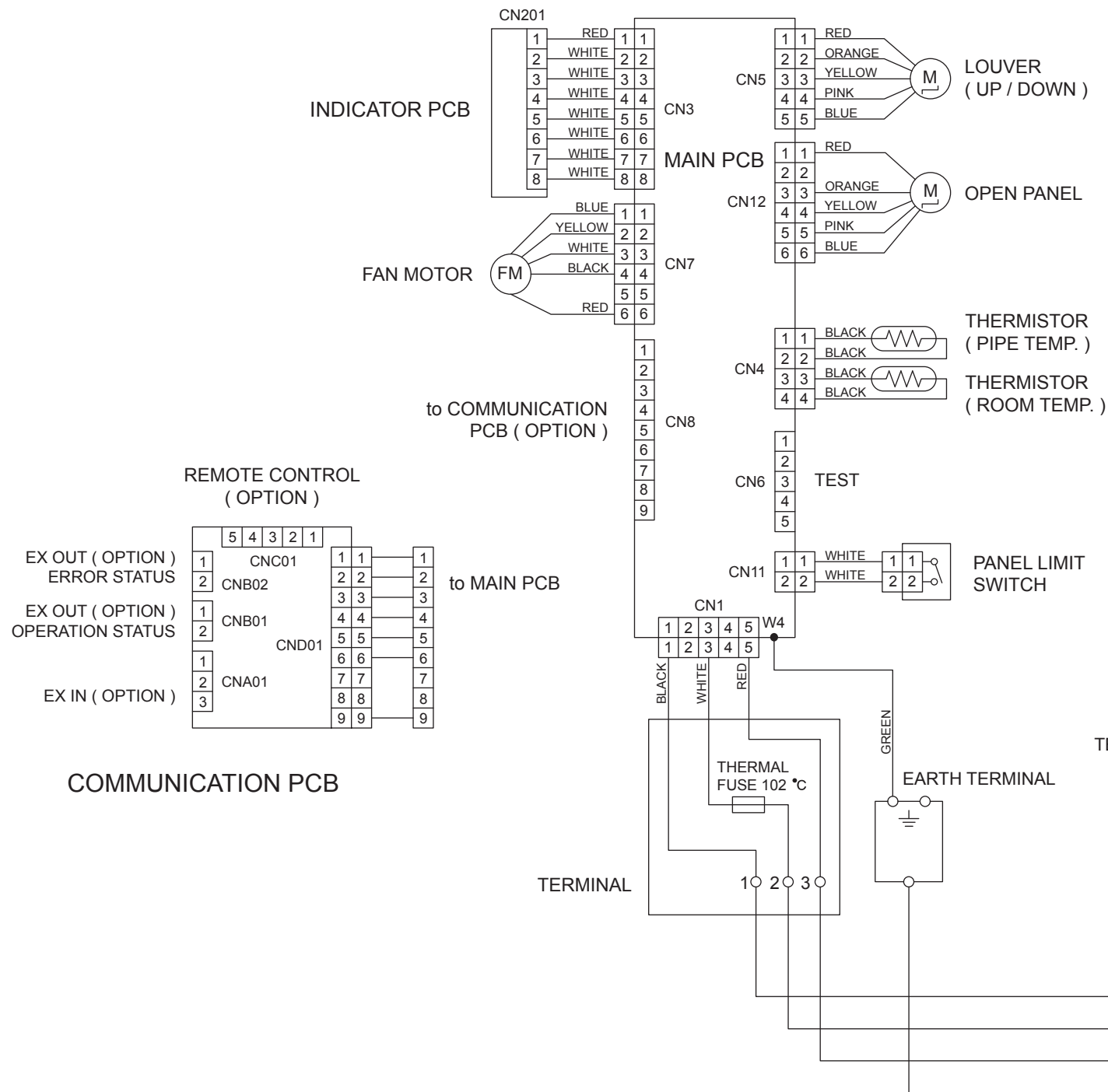

OUTDOOR UNIT

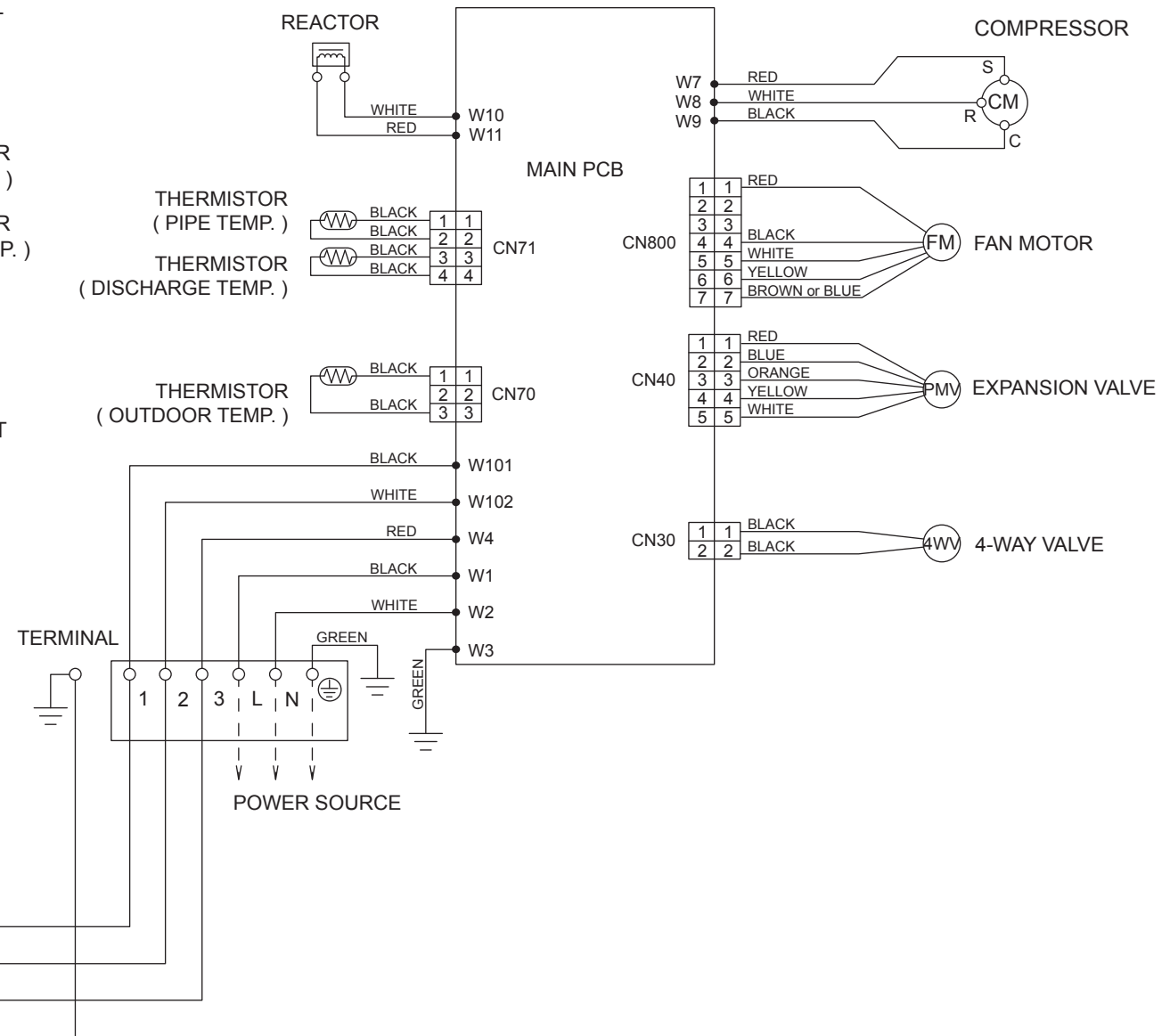

INDOOR PCB CIRCUIT DIAGRAM

CONTROL UNIT
 ASYG07LUCA : EZ-0121CHSE
 ASYG09LUCA : EZ-0121DHSE

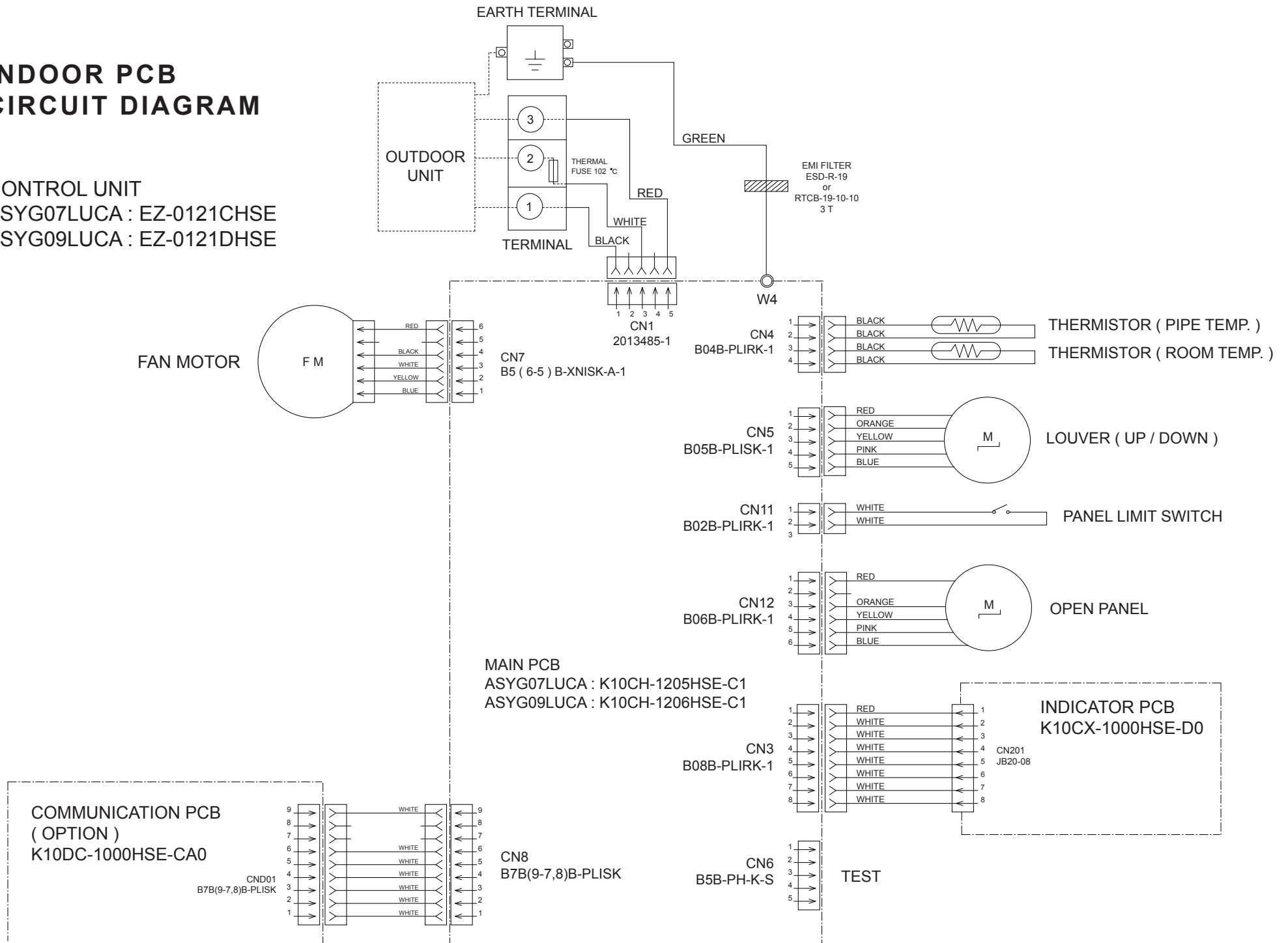

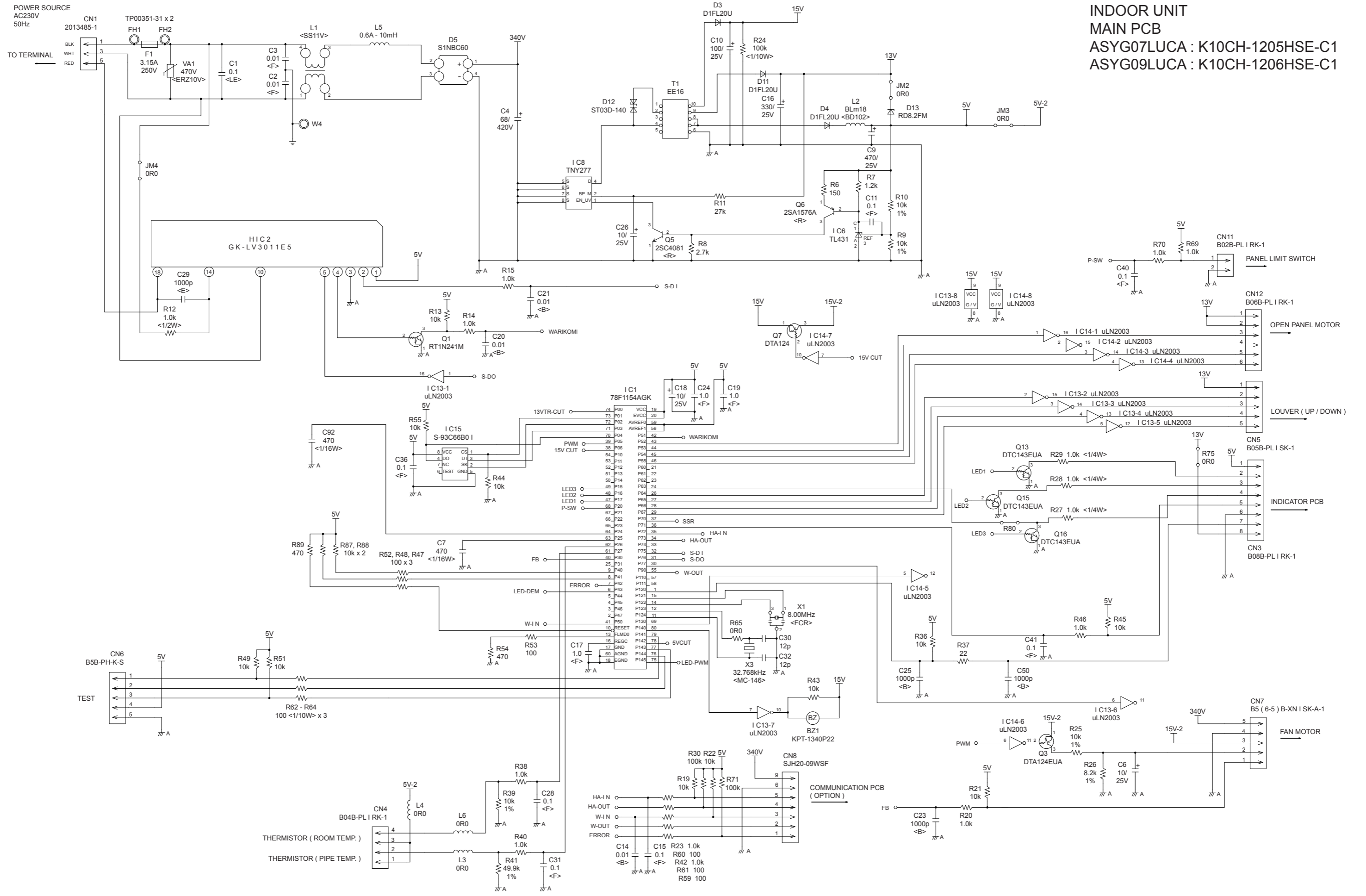

INDOOR UNIT
 MAIN PCB
 ASYG07LUCA : K10CH-1205HSE-C1
 ASYG09LUCA : K10CH-1206HSE-C1

INDOOR UNIT
 INDICATOR PCB
 K10CX-1000HSE-D0

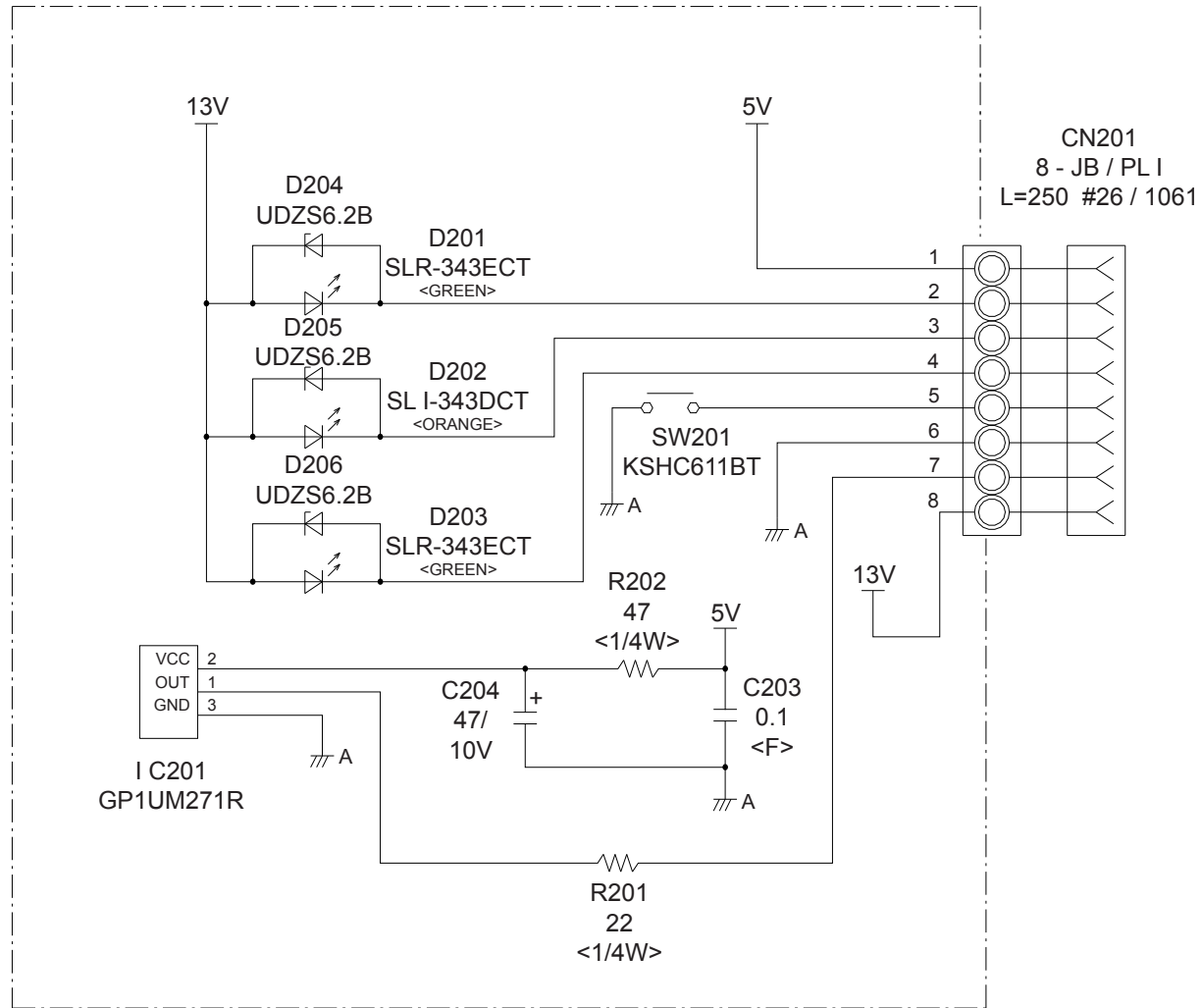

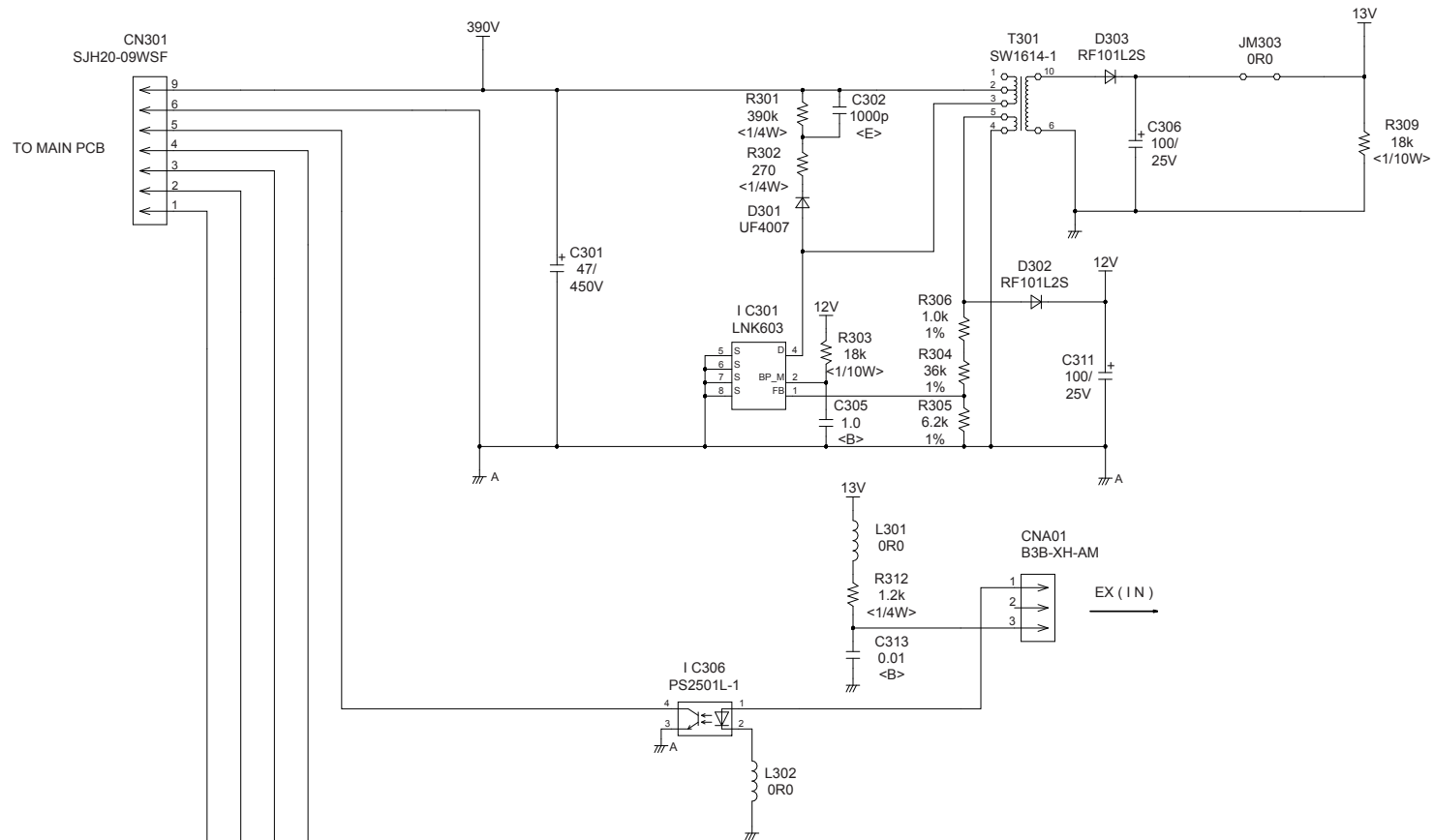

(OPTION)
 UTY-TWBXF
 COMMUNICATION PCB
 K10DC-1000HSE-CA0

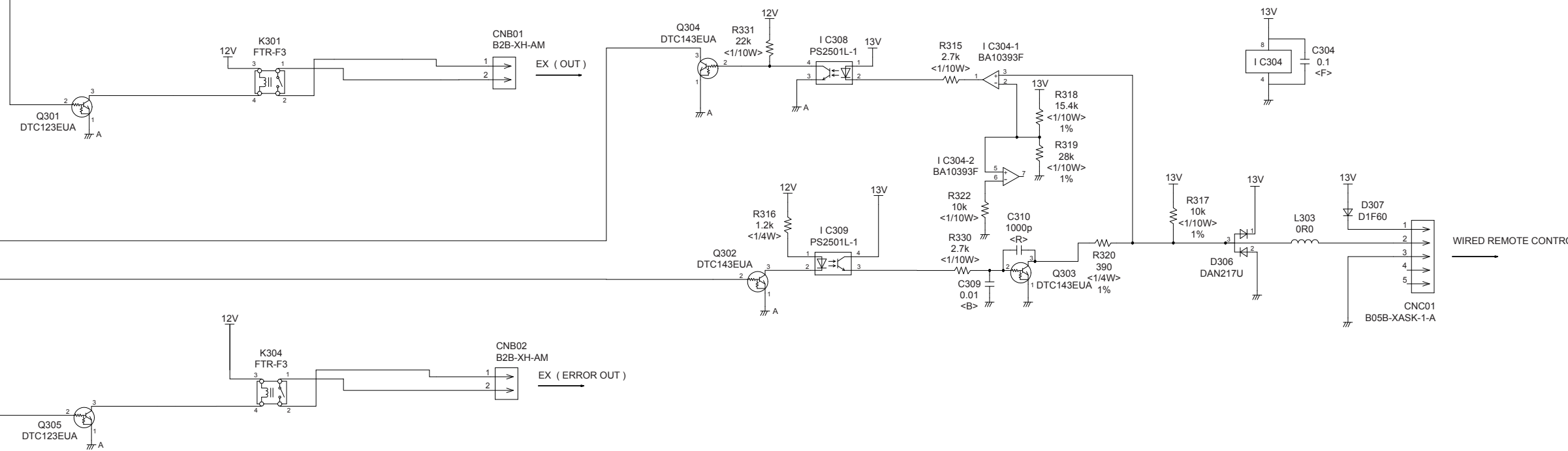

OUTDOOR PCB CIRCUIT DIAGRAM

INVERTER ASSEMBLY
 AOYG07LUCA : EZ-01211HUE
 AOYG09LUCB : EZ-01212HUE

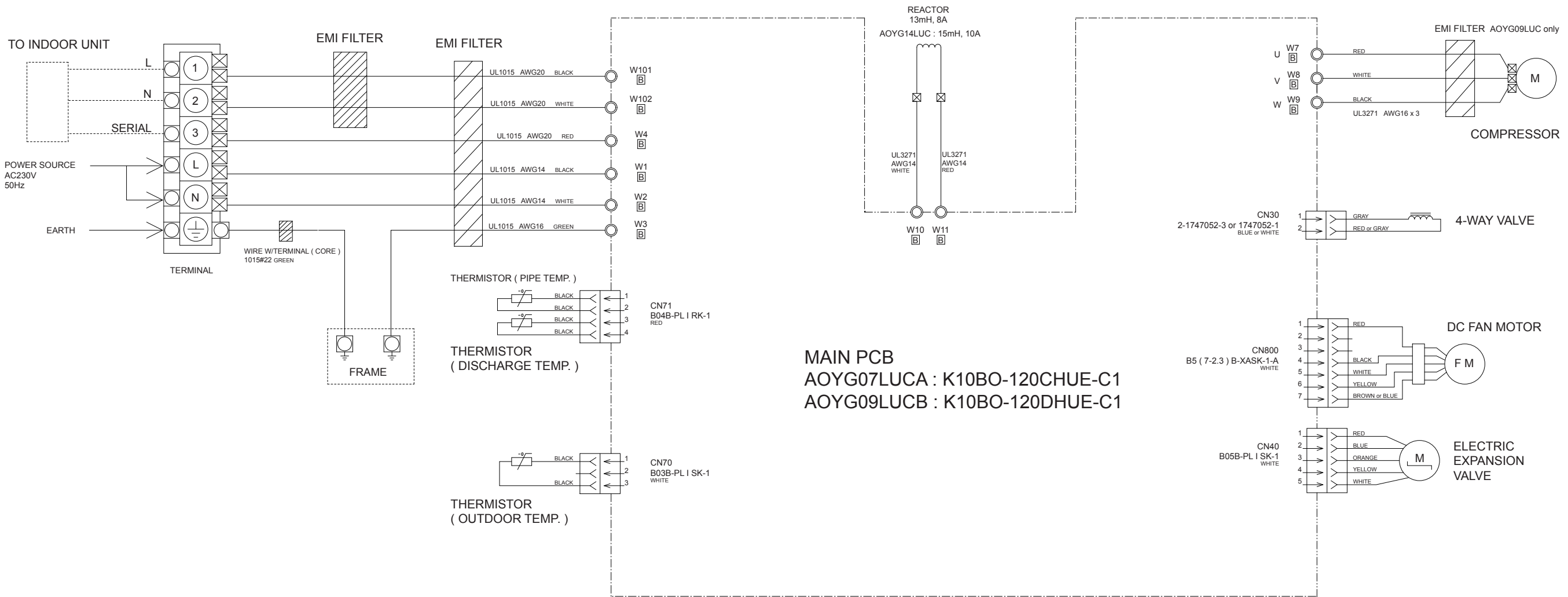

OUTDOOR UNIT
MAIN PCB
AOYG07LUCA : K10BO-120CHUE-C1
AOYG09LUCB : K10BO-120DHUE-C1

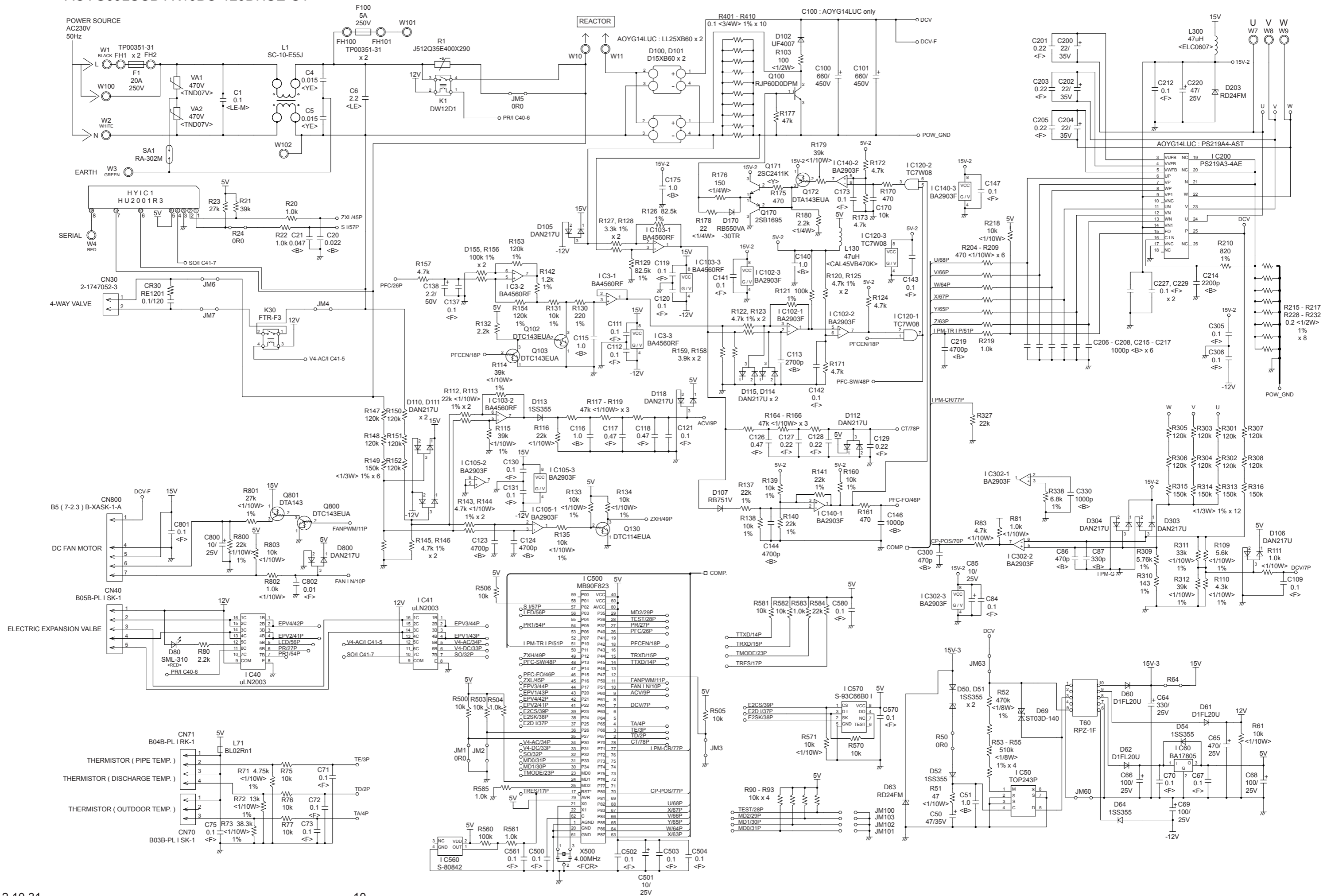

Indoor unit display

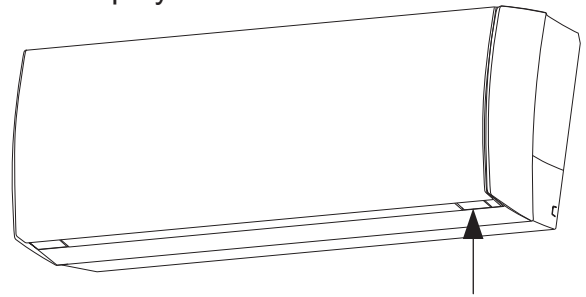

OPERATION indicator lamp (green)
 TIMER indicator lamp (orange)
 ECONOMY indicator lamp (green)

ERROR DETECTION

INDOOR UNIT REMOTE CONTROL

If you use a wireless remote control, the lamp on the photo detector unit will output error codes by way of blinking patterns.

If you use a wired remote control, error codes will appear on the remote control display.

See the lamp blinking patterns and error codes in the table.

An error display is displayed only during operation.

Wired remote control display (Option)

If an error occurs, the following display will be shown. ("Er" will appear in the set room temperature display.)

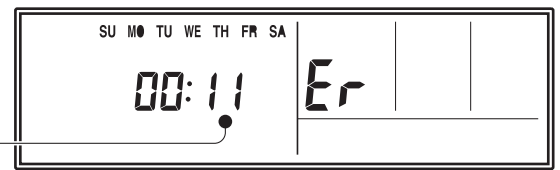

Error code

● : 0.5s ON / 0.5s OFF

() : Number of flashing

◇ : 0.1s ON
/ 0.1s OFF

Indoor unit lamp			Wired remote control	Description
OPERATION (green)	TIMER (orange)	ECONOMY (green)		
● (1)	● (1)	◇	11	Serial communication error
● (1)	● (2)	◇	12	Wired remote control communication error
● (1)	● (5)	◇	15	Check run unfinished
● (2)	● (2)	◇	22	Indoor unit capacity error
● (2)	● (3)	◇	23	Combination error
● (3)	● (2)	◇	32	Indoor unit PCB model information error
● (3)	● (5)	◇	35	Manual auto switch error
● (4)	● (1)	◇	41	Room temp. sensor error
● (4)	● (2)	◇	42	Indoor unit Heat Ex. Middle temp. sensor error
● (5)	● (1)	◇	51	Indoor unit fan motor error
● (5)	● (8)	◇	58	Intake grille error
● (5)	● (15)	◇	5U	Indoor unit error
● (6)	● (2)	◇	62	Outdoor unit main PCB model information error or communication error
● (6)	● (3)	◇	63	Inverter error
● (6)	● (4)	◇	64	Active filter error, PFC circuit error
● (6)	● (5)	◇	65	Trip terminal L error
● (6)	● (10)	◇	6A	Display PCB microcomputers communication error
● (7)	● (1)	◇	71	Discharge temp. sensor error

Indoor unit lamp			Wired remote control	Description
OPERATION (green)	TIMER (orange)	ECONOMY (green)		
● (7)	● (2)	◇	72	Compressor temp. sensor error
● (7)	● (3)	◇	73	Outdoor unit Heat Ex. liquid temp. sensor error
● (7)	● (4)	◇	74	Outdoor temp. sensor error
● (7)	● (5)	◇	75	Suction Gas temp. sensor error
● (7)	● (6)	◇	76	• 2-way valve temp. sensor error • 3-way valve temp. sensor error
● (7)	● (7)	◇	77	Heat sink temp. sensor error
● (8)	● (2)	◇	82	• Sub-cool Heat Ex. gas inlet temp. sensor error • Sub-cool Heat Ex. gas outlet temp. sensor error
● (8)	● (3)	◇	83	Liquid pipe temp. sensor error
● (8)	● (4)	◇	84	Current sensor error
● (8)	● (6)	◇	86	• Discharge pressure sensor error • Suction pressure sensor error • High pressure switch error
● (9)	● (4)	◇	94	Trip detection
● (9)	● (5)	◇	95	Compressor rotor position detection error (permanent stop)
● (9)	● (7)	◇	97	Outdoor unit fan motor error
● (9)	● (9)	◇	99	4-way valve error
● (10)	● (1)	◇	A1	Discharge temp. error
● (10)	● (3)	◇	A3	Compressor temp. error
● (10)	● (4)	◇	A4	High pressure error
● (10)	● (5)	◇	A5	Low pressure error

OUTDOOR UNIT

LED	ERROR
on	Discharge temperature abnormal
0.5 second on / 0.5 second off	IPM overcurrent protection
0.1 second on / 0.1 second off	Thermistor abnormal
2.0 second on / 2.0 second off	CT abnormal
0.1 second on / 2.0 second off	Compressor location abnormal
5.0 second on / 5.0 second off	Fan abnormal

PARTS

INDOOR UNIT
ASYG07LUCA
ASYG09LUCA

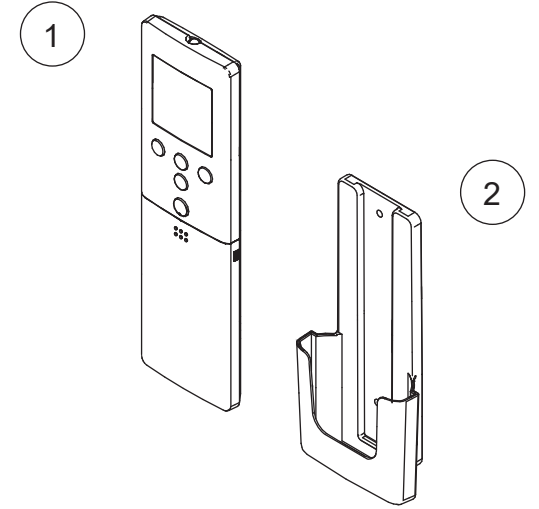
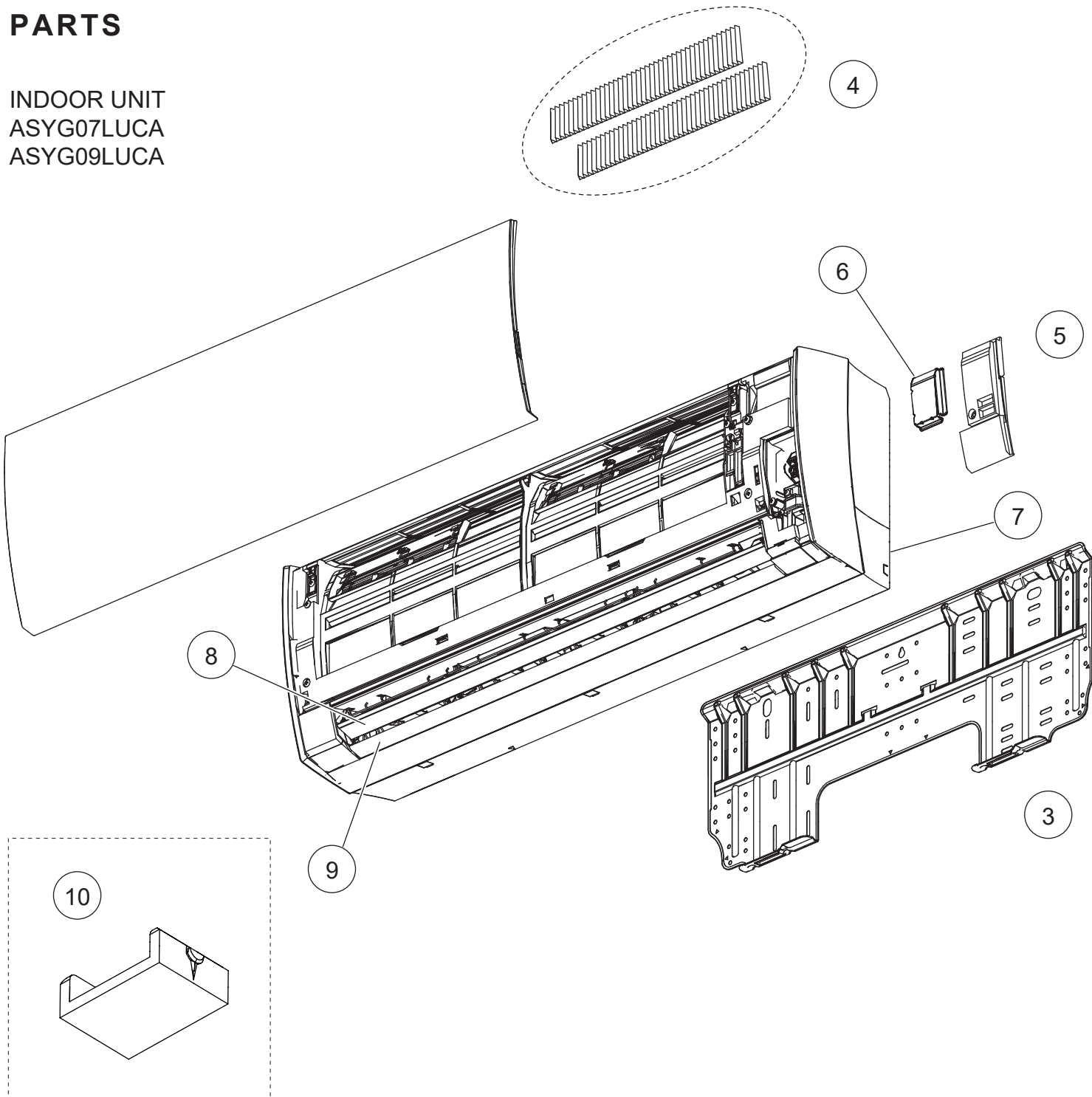

Ref.	Description	Part number
1	Remote Control	9319207018
2	Remote Control Holder	9318912005
3	Bracket Panel	9318913002
4	Air Clean Filter Assy	9317250009
5	Wire Cover	9318911015
6	Wire Shield	9318919004
7	Under Cover	9318879018
8	Louver U (Upper)	9318880007
9	Louver Z (Lower)	9318881004
10	Screw cap	9309002067

INDOOR UNIT
Front panel

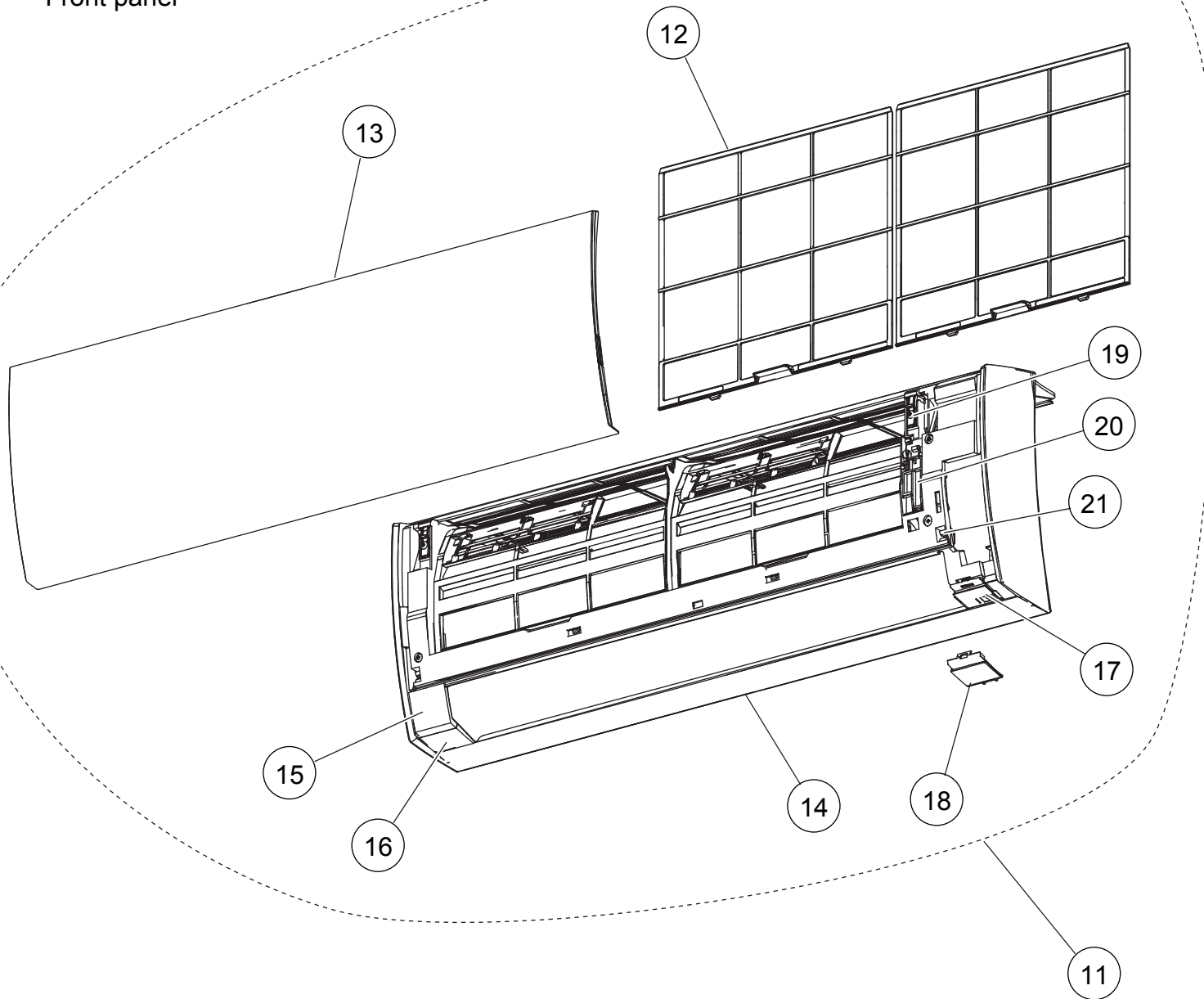

Ref.	Description	Part number
11	Front Panel Total Assy	9319348001
12	Air Filter	9318883008
13	Intake Grille Assy	9319351155
14	Front Panel	9318876000
15	Front Panel Cover U	9318910001
16	Display Plate Holder L	9318894004
17	Display Plate Holder R	9318895001
18	Display Plate R	9318893007
19	Arm Cover	9318900002
20	Grille Stay	9318899016
21	Grille Clamper B	9316951006

Intake grill assy

Ref.	Description	Part number	
a	Grille gear	9319292014	

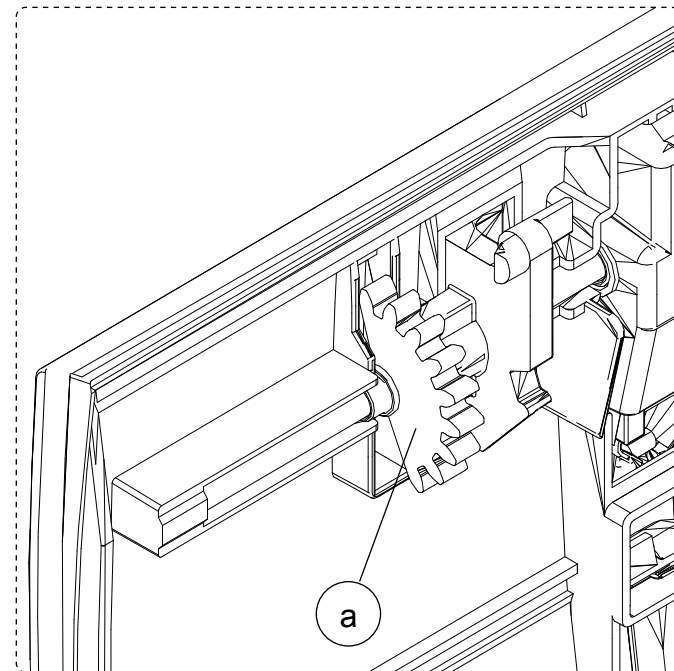
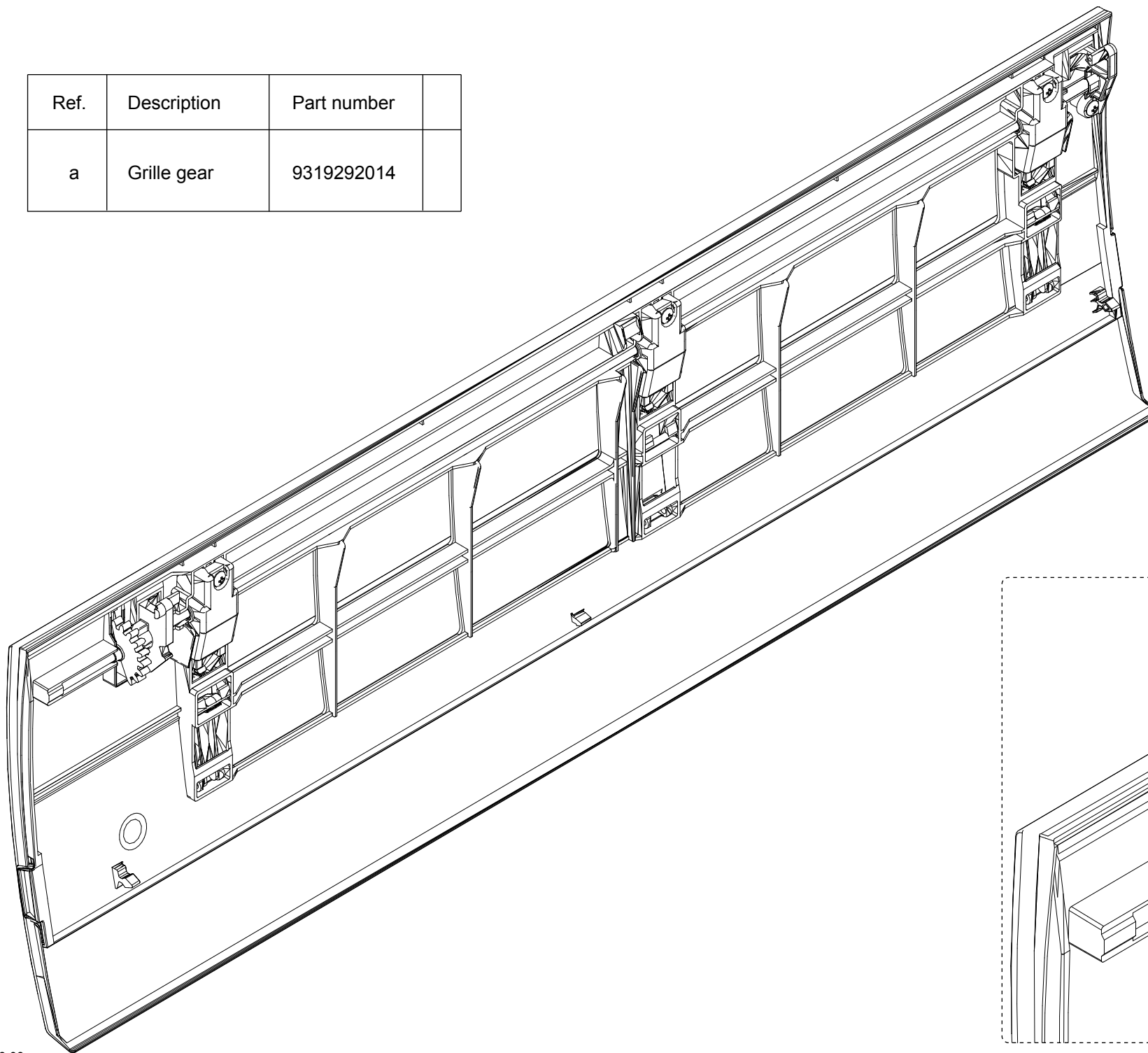

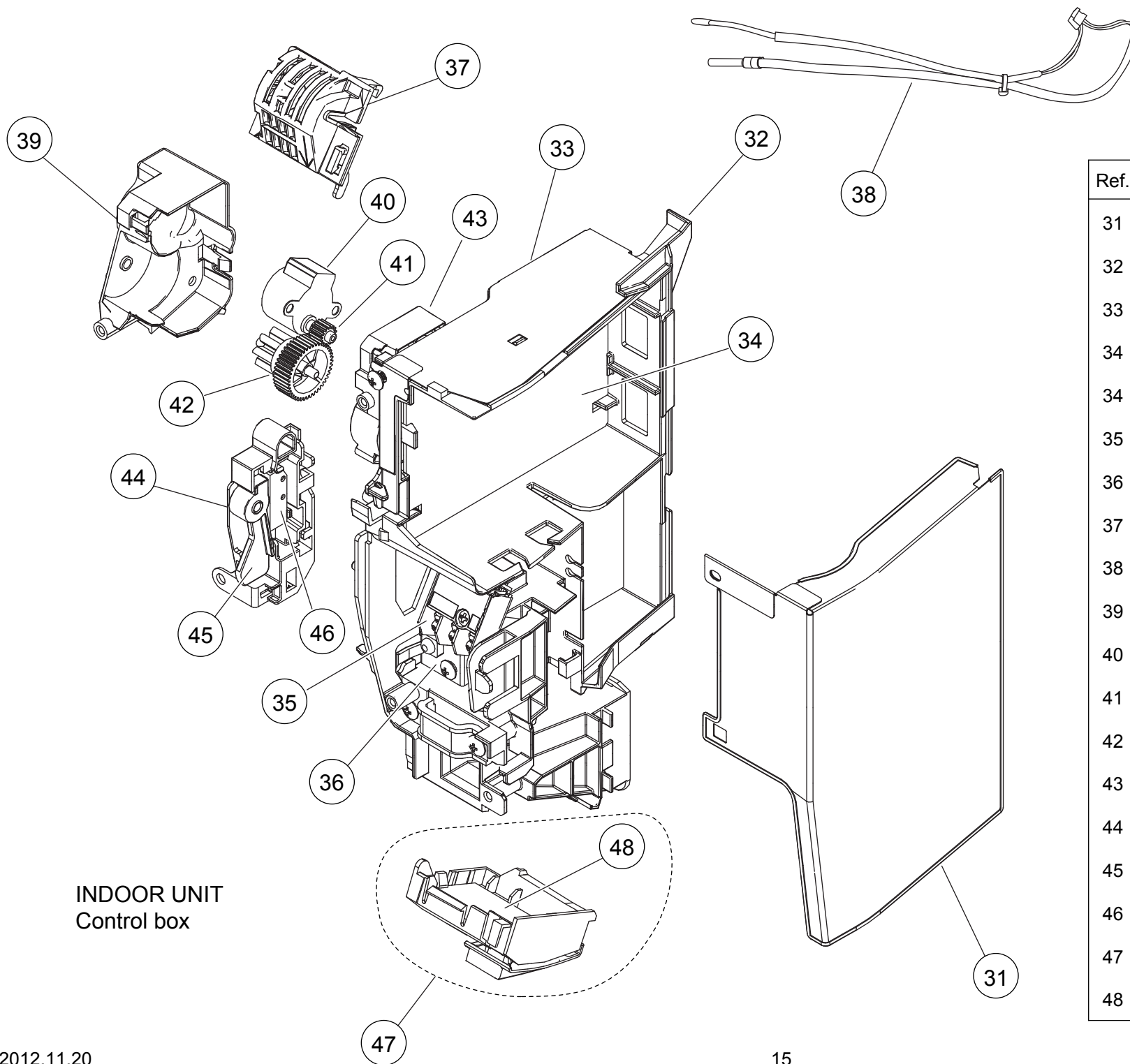

Ref.	Description	Part number
31	Cover Shield A	9318916003
32	Control Box	9318882049
33	Box Shield Assy	9319344010
34	Main PCB (07)	9708713281
34	Main PCB (09)	9708713298
35	Terminal	9900638009
36	Earth Terminal	9318918007
37	Room Thermistor Holder	9319068008
38	Thermistor Assy	9900627003
39	Gear Cover	9318902006
40	Step Motor	9900384166
41	Gear B	9319294001
42	Panel Gear	9319293004
43	Gear Case	9318903003
44	Switch Case	9319332000
45	Grille Key Top	9319334004
46	Micro Switch	9900625009
47	Display Assy	9708823010
48	Display PCB	9708824017

INDOOR UNIT
Casing assy

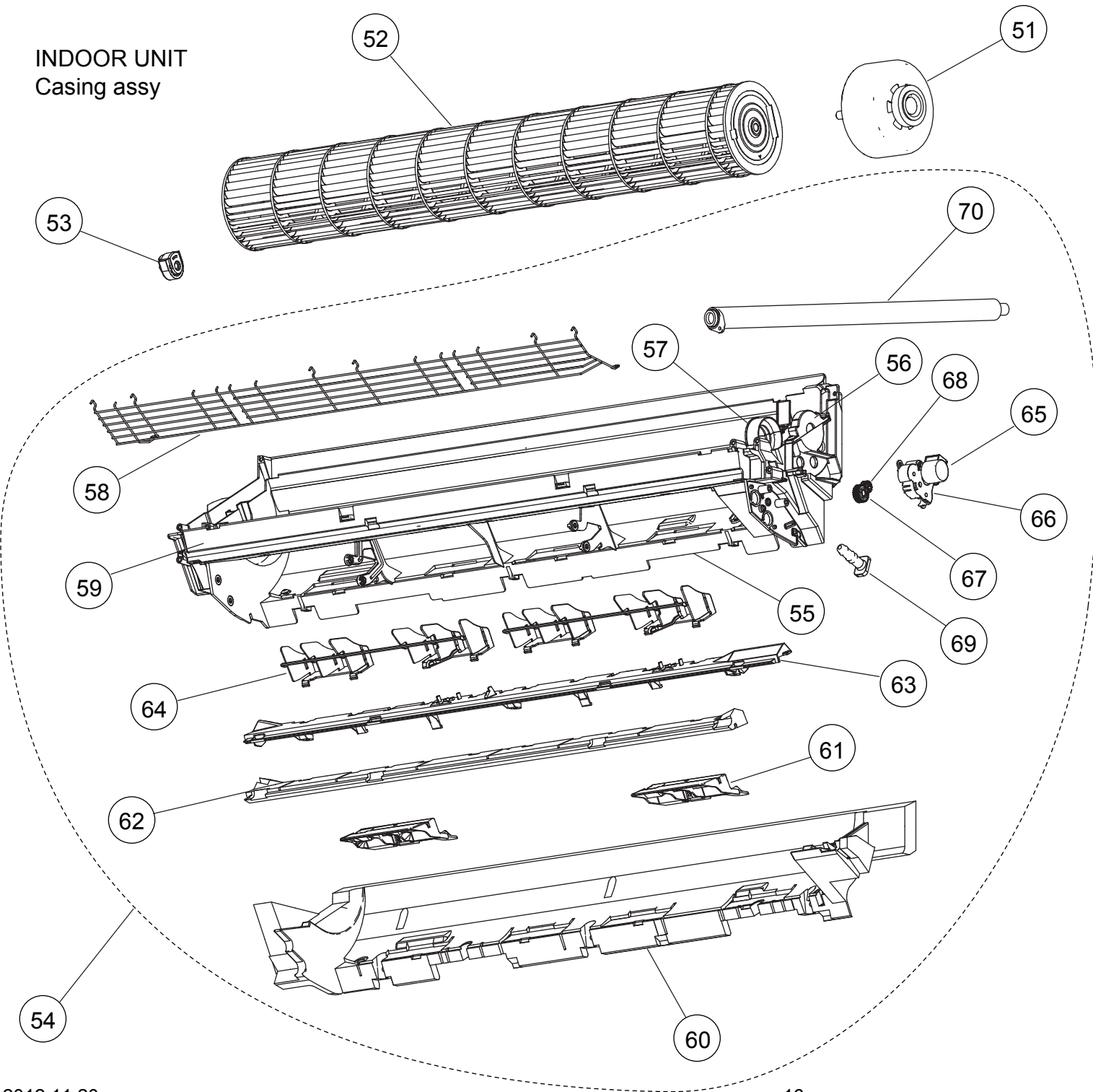

Ref.	Description	Part number
51	Fan Motor	9602947003
52	Crossflow Fan Assy	9319361000
53	Bearing C Assy	9306628017
54	Casing Assy	9319342009
55	Casing	9318873009
56	Motor Cover	9316601000
57	Motor Cover	9318888003
58	Fan Guard	9318924008
59	Casing Cover F	9318923001
60	Casing Cover B	9318920017
61	Pipe Bracket	9318889000
62	Panel Cover	9319296012
63	Louver Holder	9318886009
64	R and L Louver	9318885002
65	Motor Step	9900384128
66	Louver Gear Holder	9318905007
67	Louver Gear	9318904000
68	Gear A	9309994003
69	Drain Cap	9316177017
70	Drain Hose Assy	9316904002

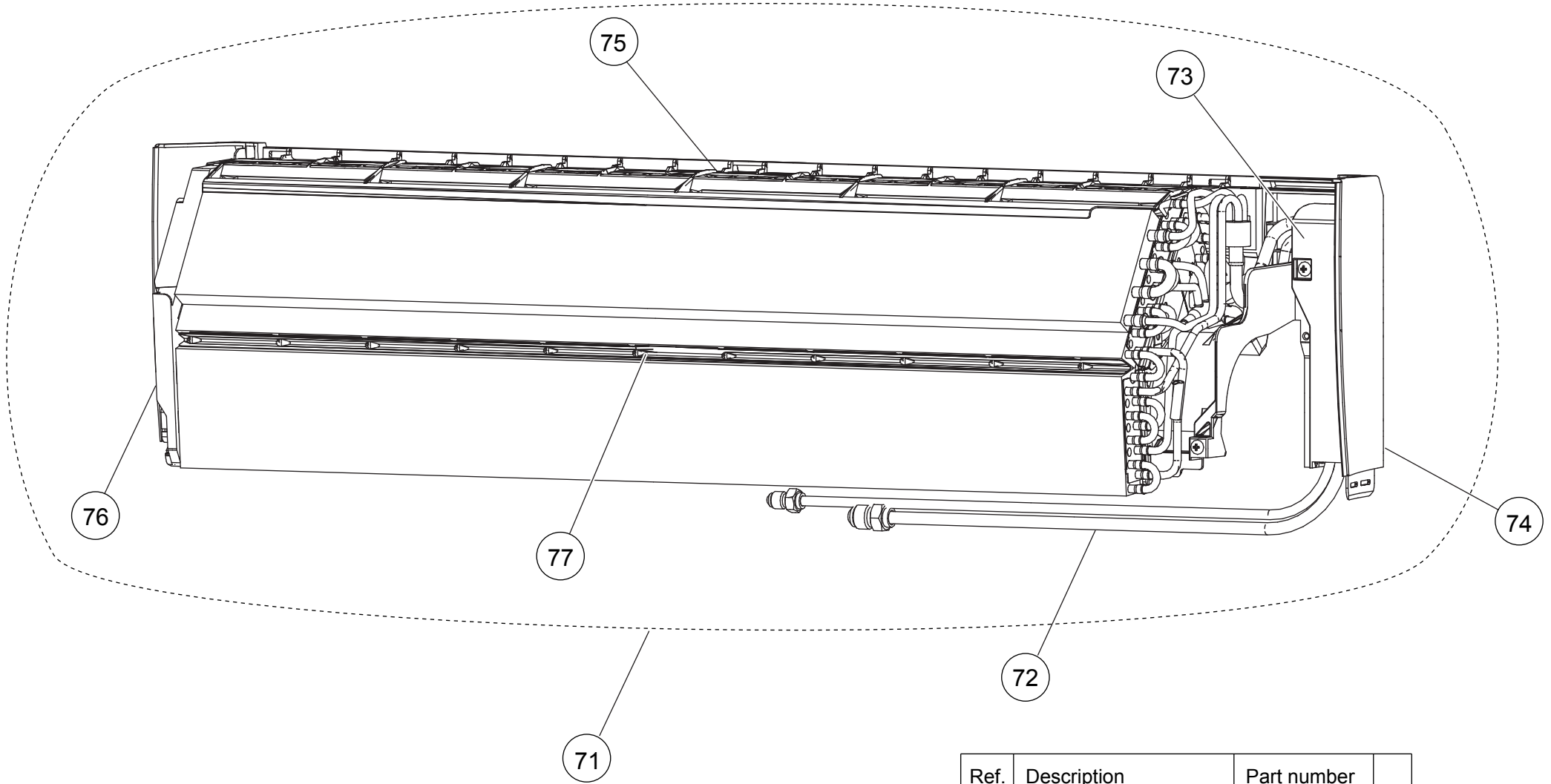

INDOOR UNIT
Evaporator

Ref.	Description	Part number
71	Evaporator Total Assy	9319327006
72	Joint Pipe Assy	9319322001
73	Joint Pipe Holder	9318901009
74	Base	9318874006
75	Filter Guide	9318887006
76	Evaporator Holder L	9318875003
77	Air Seal	9319295008

PARTS

OUTDOOR UNIT

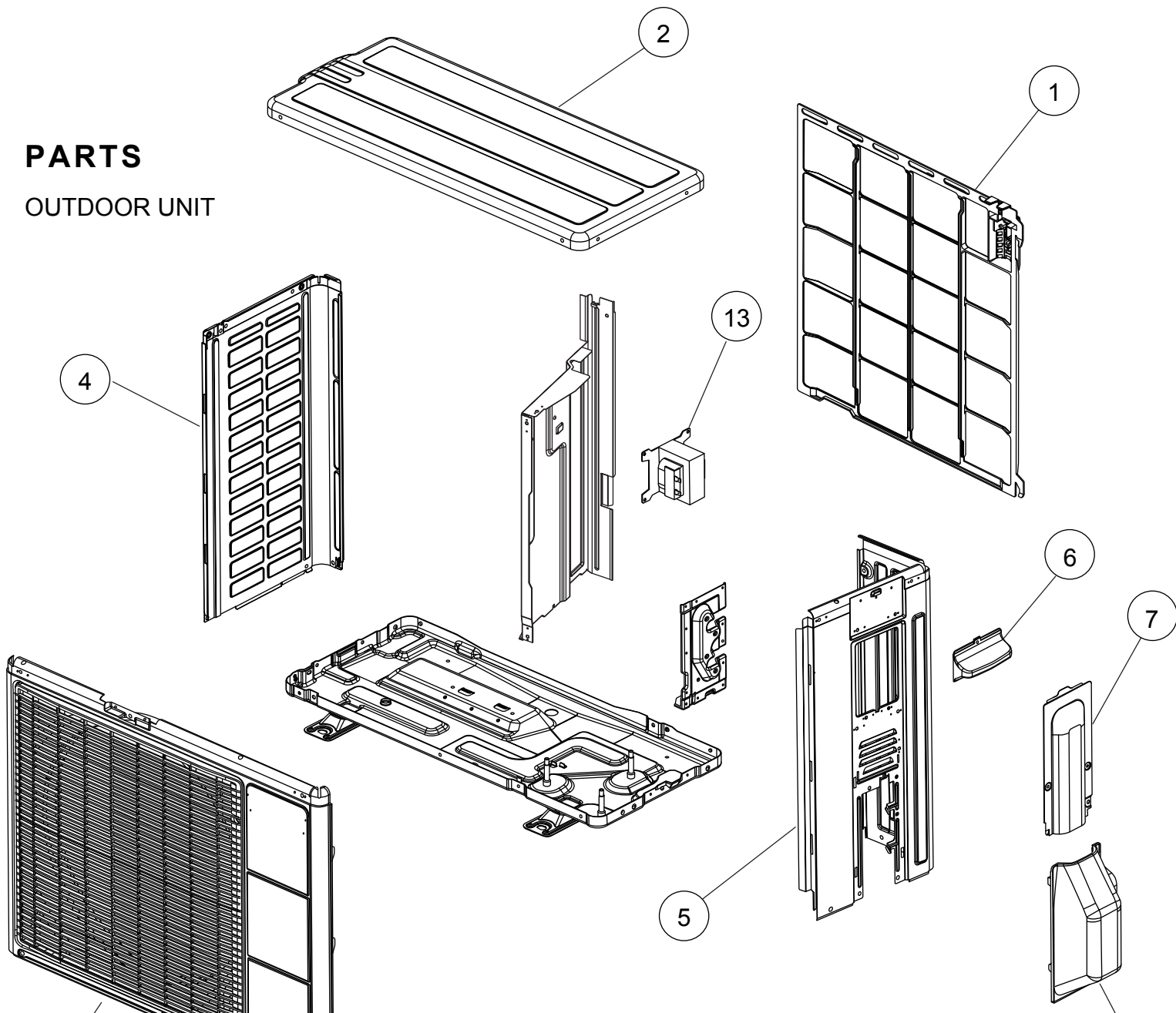

Ref.	Description	Part number
1	Protective Net	9331262033
2	Top Panel Assy	9317939027
3	Front Panel Assy	9317789028
4	Cabinet Left Assy	9317813006
5	Cabinet Right Assy	9317788021
6	Grip	9317588003
7	Switch Cover A Assy	9317795005
8	Switch Cover B	9317582001
11	Fan Motor	9603074036
12	Propeller Fan	9309909014
13	Reactor Assy	9900583002
--	Emblem	9319151007
--	Drain Assy	9303029022

OUTDOOR UNIT

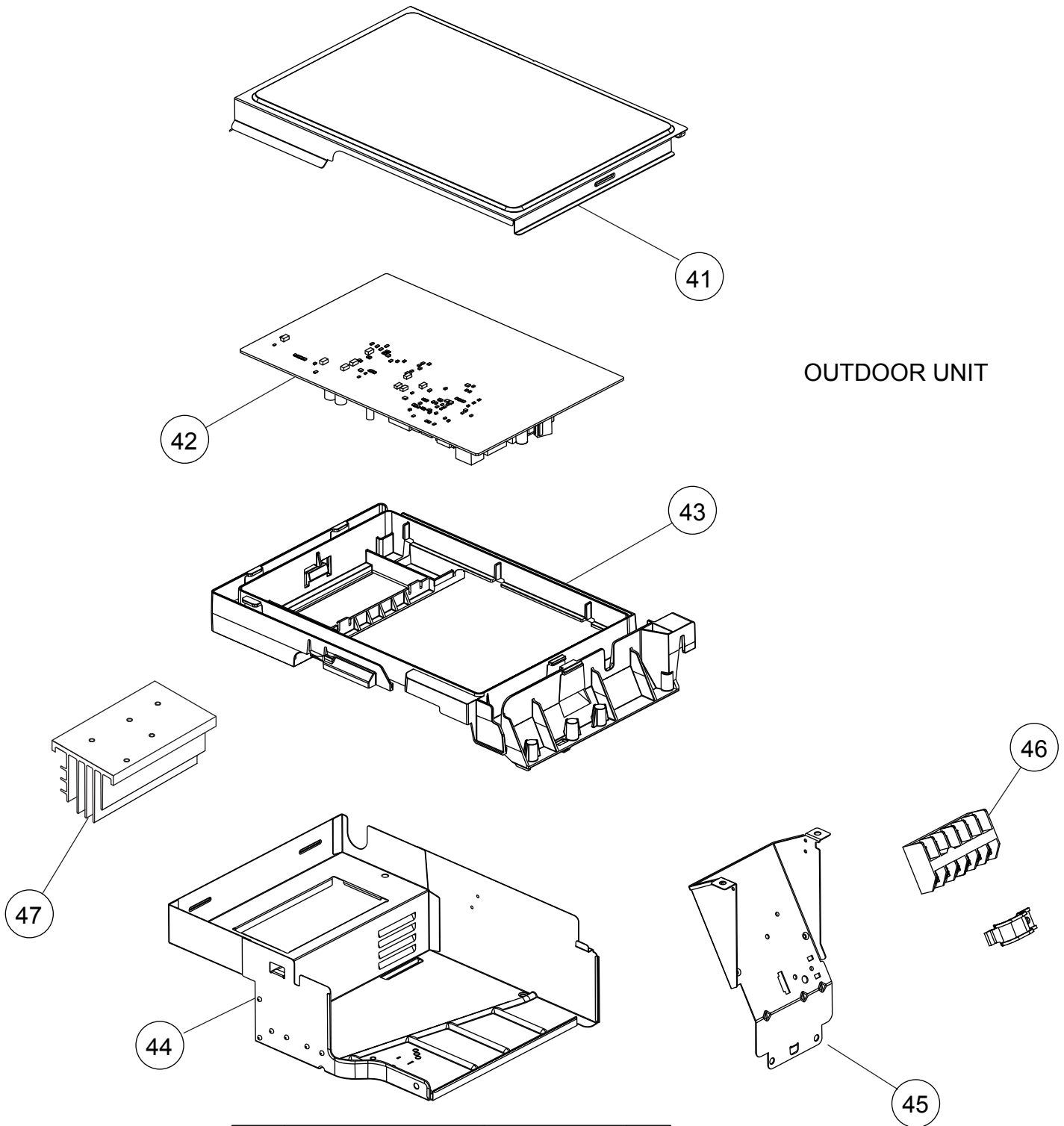

Ref.	Description	Part number	
41	Sealed Panel	9318181012	
42	Main PCB (07)	9708683409	
42	Main PCB (09)	9708683416	
43	PCB Holder	9318182019	
44	Inverter Case Assy	9332247015	
45	Terminal Bracket	9317816052	
46	Terminal	9900435028	
47	Heat Sink	9319070001	
--	Outdoor Thermistor	9900565008	
--	Thermistor Assy	9900628000	

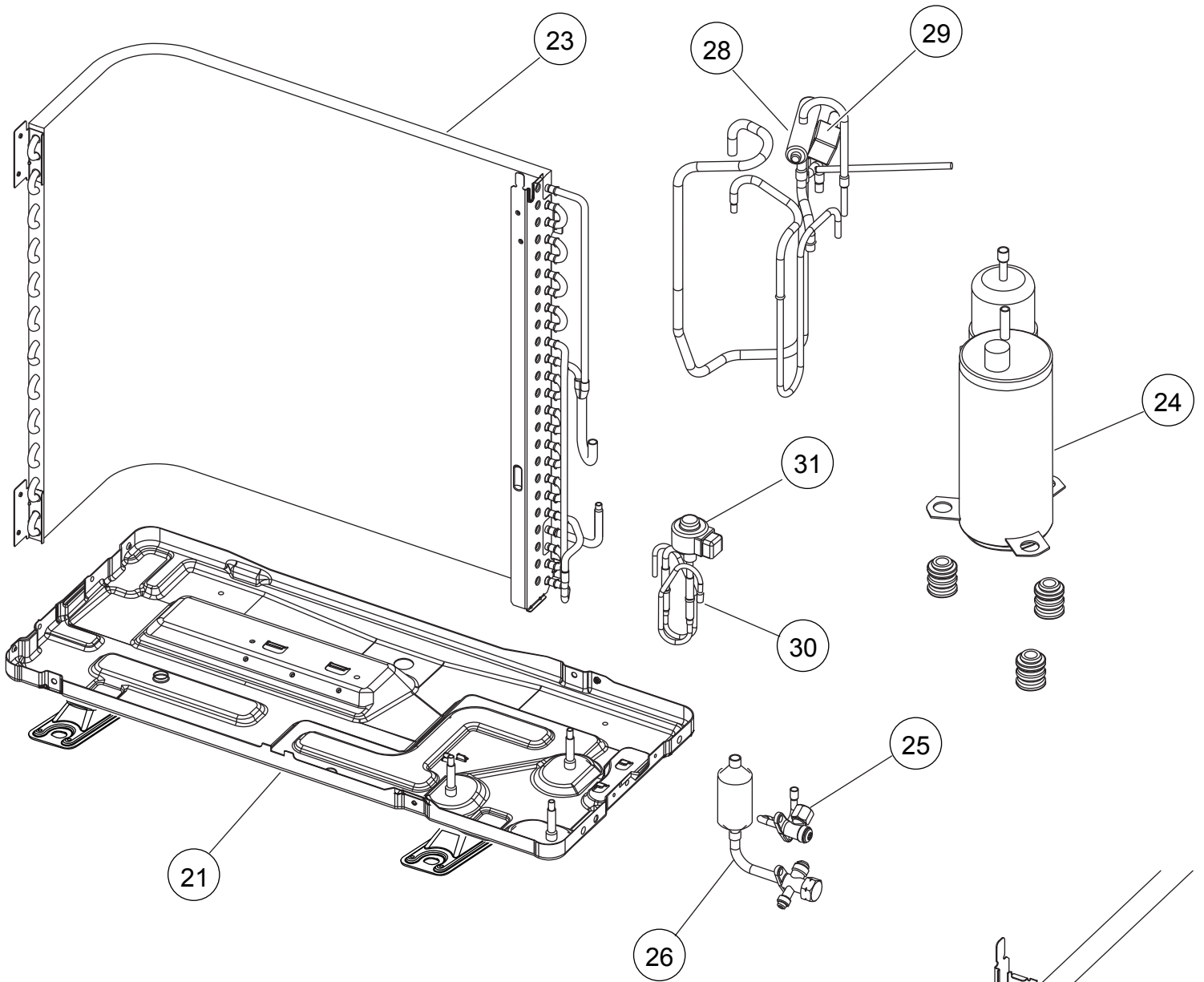

**OUTDOOR UNIT
AOYG07LUCA**

Ref.	Description	Part number
21	Base Assy	9316916029
23	Condenser Total Assy	9317287012
24	Compressor Assy	9317083034
25	2-way Valve Sub Assy	9317345033
26	3-way Valve Sub Assy	9317366038
28	4-way Valve Assy	9317890021
29	Solenoid	9970079023
30	Pulse Motor Valve Assy	9317216036
31	Expansion Valve Coil	9970103025

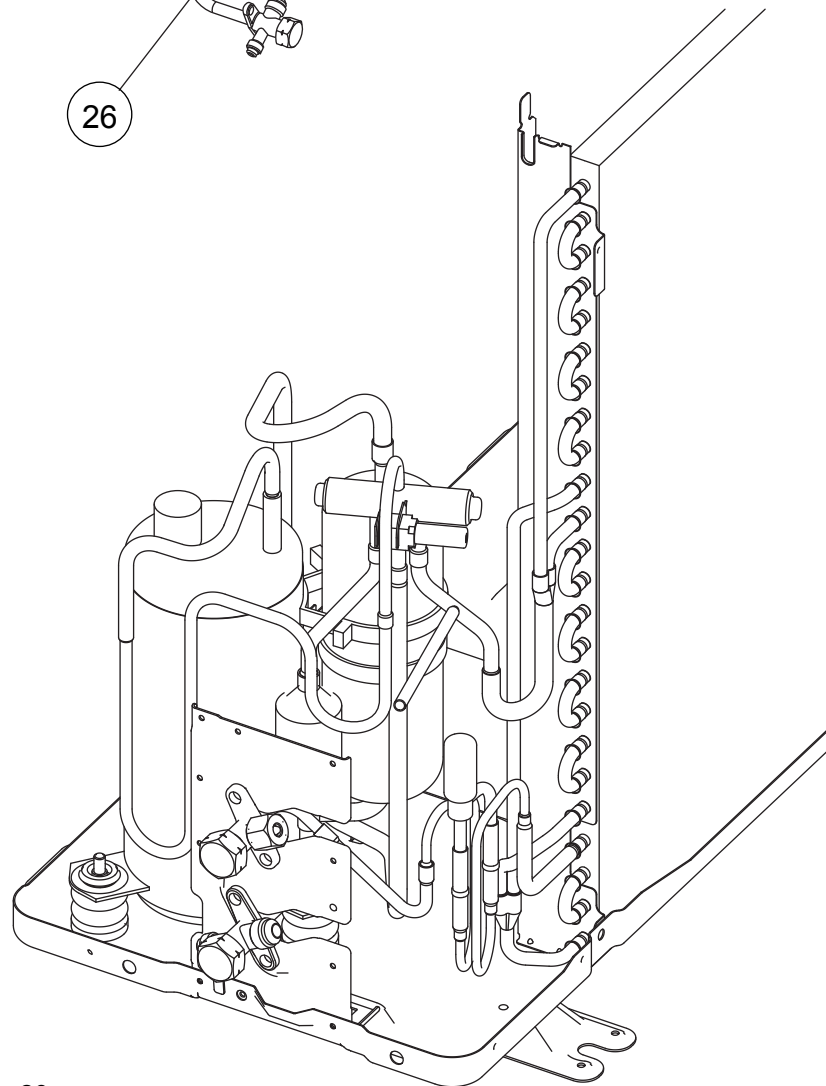

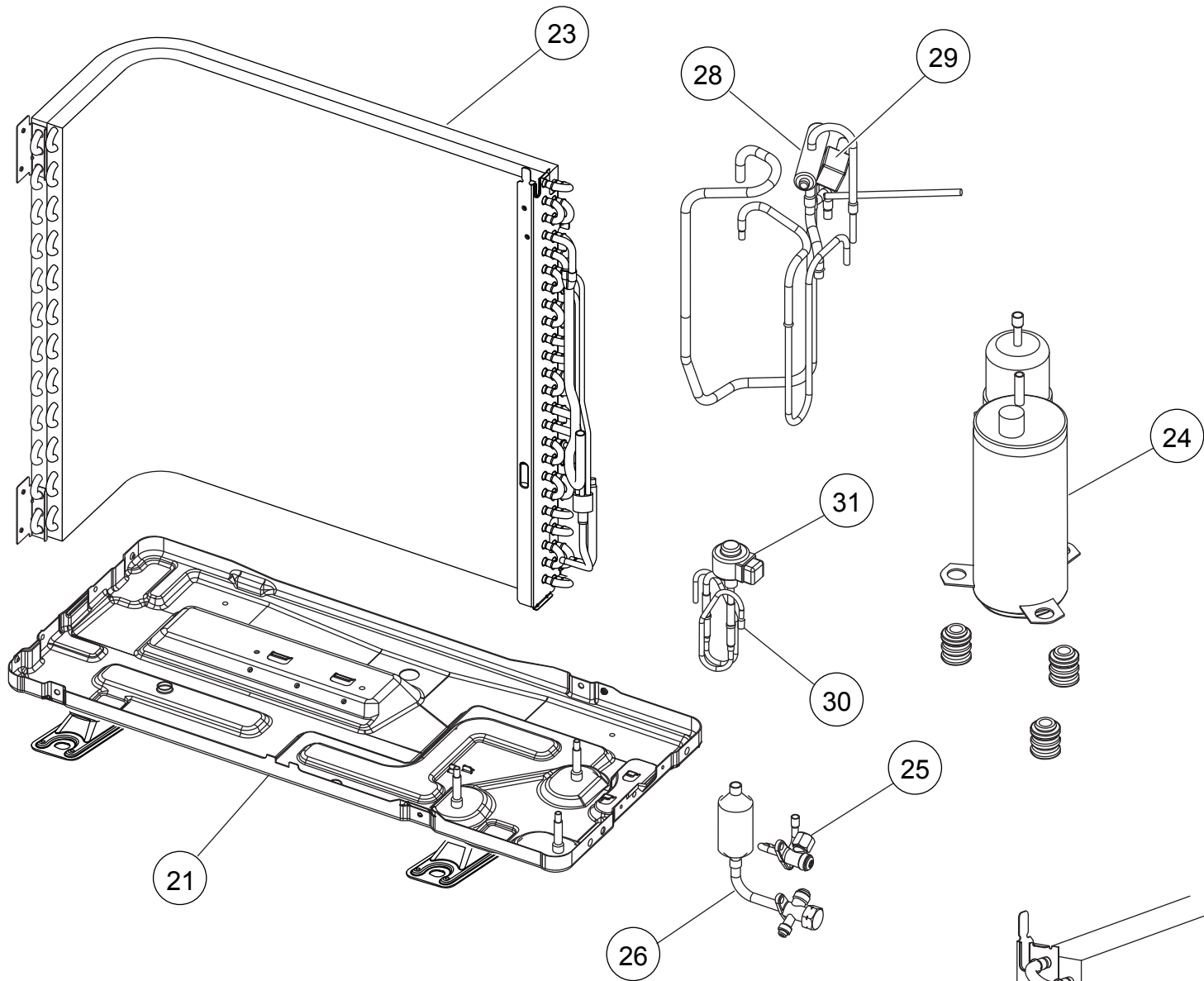

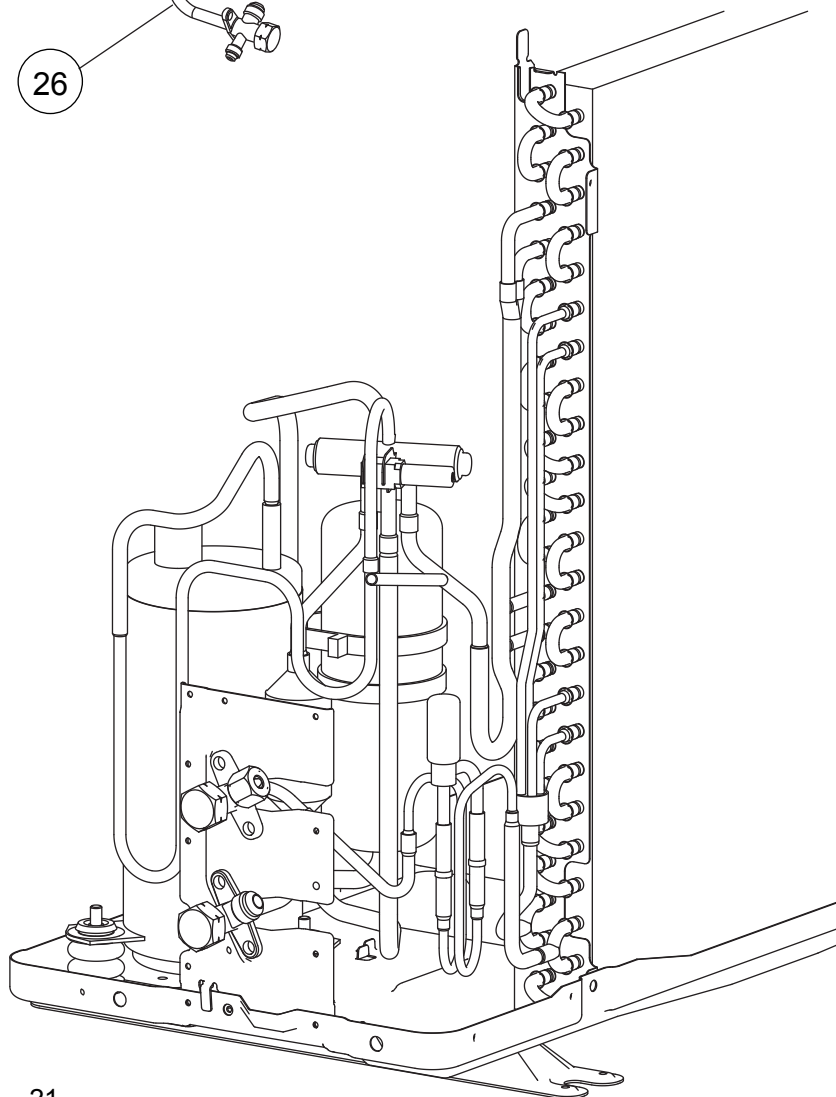

**OUTDOOR UNIT
AOYG09LUCB**

Ref.	Description	Part number
21	Base Assy	9316916029
23	Condenser Total Assy	9317367103
24	Compressor Assy	9317083034
25	2-way Valve Sub Assy	9317345033
26	3-way Valve Sub Assy	9317366038
28	4-way Valve Assy	9317890021
29	Solenoid	9970079023
30	Pulse Motor Valve Assy	9317216036
31	Expansion Valve Coil	9970103025

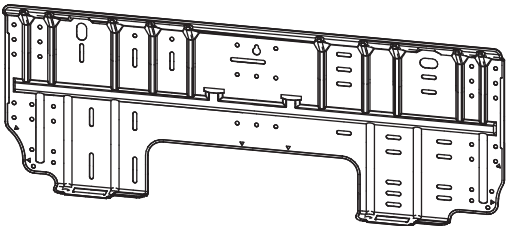
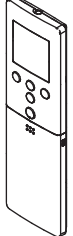
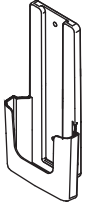

ACCESSORIES

INDOOR UNIT

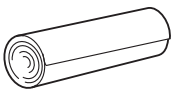
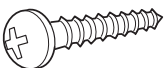
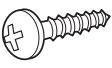
Name and Shape	Part number
Bracket panel 	9318913002
Remote control 	9319207018
Remote control holder 	9318912005
Battery (penlight) 	0600185077
Cloth tape 	9308117007
Tapping screw (big) (φ 4 x 25) 	0700076046
Tapping screw (small) (φ 3 x 12) 	0700019036

OPTION

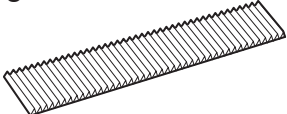
Name and Shape	Part number
Air cleaning filter 	UTR-FA16 UTR-FA16-2

1211G4124