

SPLIT TYPE
AIR CONDITIONER
DUCT TYPE (50Hz)

SERVICE MANUAL

Indoor unit	Outdoor unit
ARYG45LHTA	AOYG45LATT
ARYG54LHTA	AOYG54LATT



CONTENTS

SPECIFICATIONS	1
DIMENSIONS	2
REFRIGERANT SYSTEM DIAGRAM . . .	4
CIRCUIT DIAGRAM	5
INDOOR PCB CIRCUIT DIAGRAM	6
OUTDOOR PCB CIRCUIT DIAGRAM . . .	7
ERROR DETECTION	14
PARTS (INDOOR UNIT)	18
PARTS (OUTDOOR UNIT)	20
ACCESSORIES	23

SPECIFICATIONS

ELECTRICAL DATA

TYPE		Cooling & Heating	
INDOOR UNIT		ARYG45LHTA	ARYG54LHTA
OUTDOOR UNIT		AOYG45LATT	AOYG54LATT
COOLING CAPACITY		12.5 kW	14.0 kW
HEATING CAPACITY		14.0 kW	16.0 kW
POWER SOURCE		400 V, 50 Hz, 3 phase, 4 W	
RUNNING CURRENT	Cooling	6.1 A	6.9 A
	Heating	5.5 A	6.5 A
INPUT WATTS	Cooling	4.06 kW	4.65 kW
	Heating	3.67 kW	4.37 kW
E.E.R.	Cooling	3.08 kW/kW	3.01 kW/kW
C.O.P.	Heating	3.81 kW/kW	3.66 kW/kW
MOISTURE REMOVAL		1.5 L/hr	2.5 L/hr
AIRCIRCULATION INDOOR		3,350 m3/h	3,350 m3/h
AIRCIRCULATION OUTDOOR	Cooling	6,750 m3/h	6,900 m3/h
	Heating	6,200 m3/h	6,900 m3/h
MAXIMUM CURRENT		11.0 A	12.0 A

FAN MOTOR

INDOOR UNIT, Discrimination		MFA-60TTFS	
INDOOR UNIT	High	1,300 r.p.m.	
	Medium	1,150 r.p.m.	
	Low	1,000 r.p.m.	
OUTDOOR UNIT, Discrimination		MFE-54VVT	
OUTDOOR UNIT Cooling	Upper fan	850 r.p.m.	900 r.p.m.
	Lower fan	800 r.p.m.	800 r.p.m.
OUTDOOR UNIT Heating	Upper fan	780 r.p.m.	870 r.p.m.
	Lower fan	750 r.p.m.	840 r.p.m.

NOISE LEVEL

INDOOR UNIT	High	47 dB	
	Medium	43 dB	
	Low	40 dB	
OUTDOOR UNIT	Cooling	54 dB	55 dB
	Heating	54 dB	56 dB

COMPRESSOR AND REFRIGERANT

TYPE		Hermetic type, Inverter, 4 poles, 3 phase, DC motor, Twin Rotary	
DISCRIMINATION		DA422A3F-29ZAD	
WEIGHT (with oil)		23.0 kg	
REFRIGERANT TYPE		R410A	
PRECHARGED REFRIGERANT		3,450 g	
MAX PIPE HEIGHT		30 m	
FULL CHARGE	Pipe length	30 m	3,450 g
		45 m	4,200 g
		60 m	4,950 g
		75 m	5,700 g
ADDITIONAL CHARGE		50 g/m	

DIMENSIONS

INDOOR UNIT	H x W x D	400 x 1,050 x 500 mm
OUTDOOR UNIT	H x W x D	1,290 x 900 x 330 mm

WEIGHT

INDOOR UNIT	Shipping / Net	51 kg / 46 kg
OUTDOOR UNIT	Shipping / Net	113 kg / 104 kg

DIMENSIONS

INDOOR UNIT
(Unit : mm)

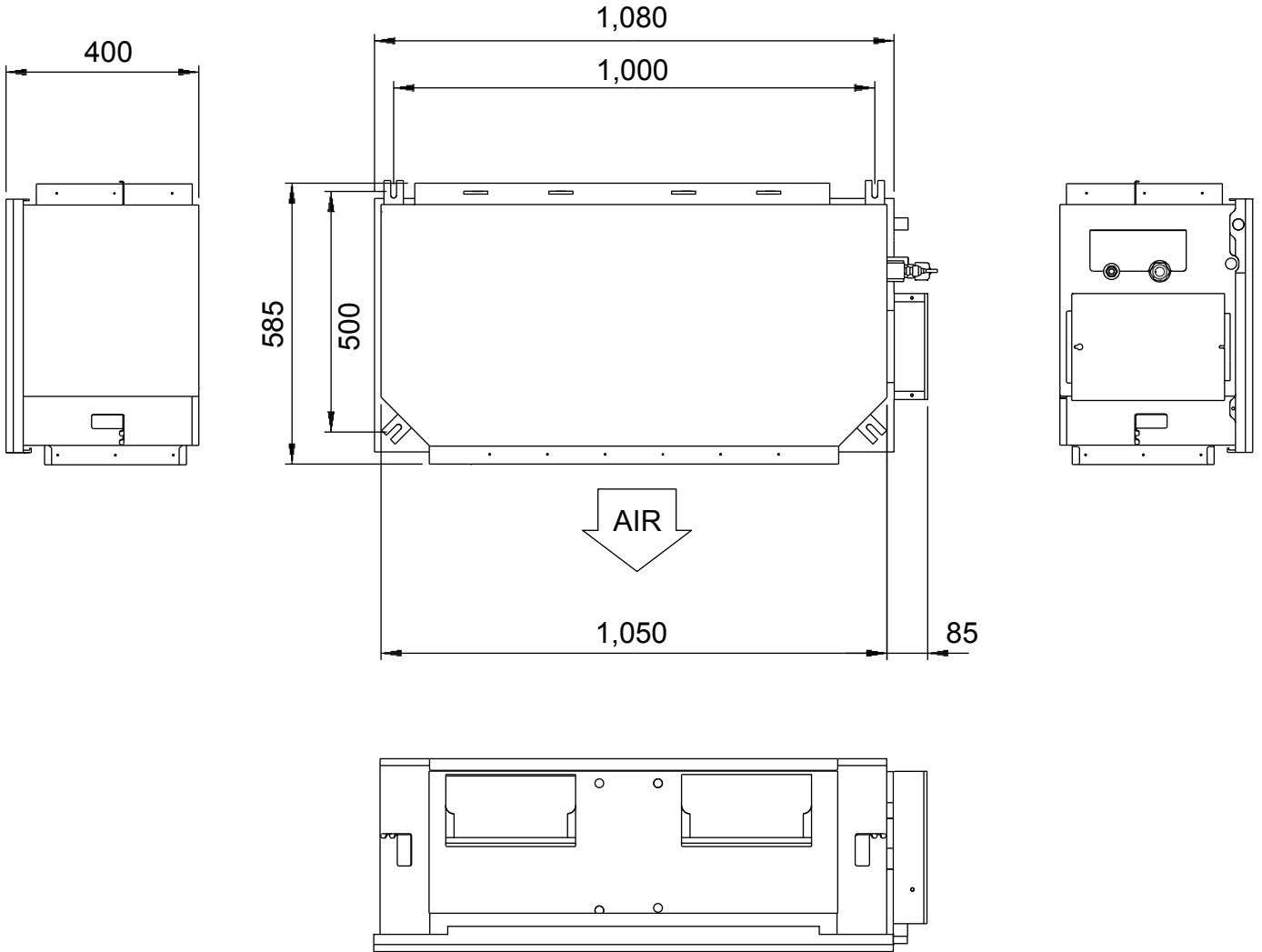
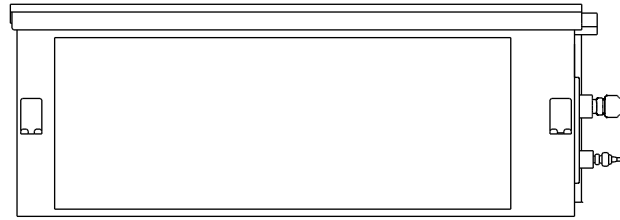

OUTDOOR UNIT
(unit : mm)

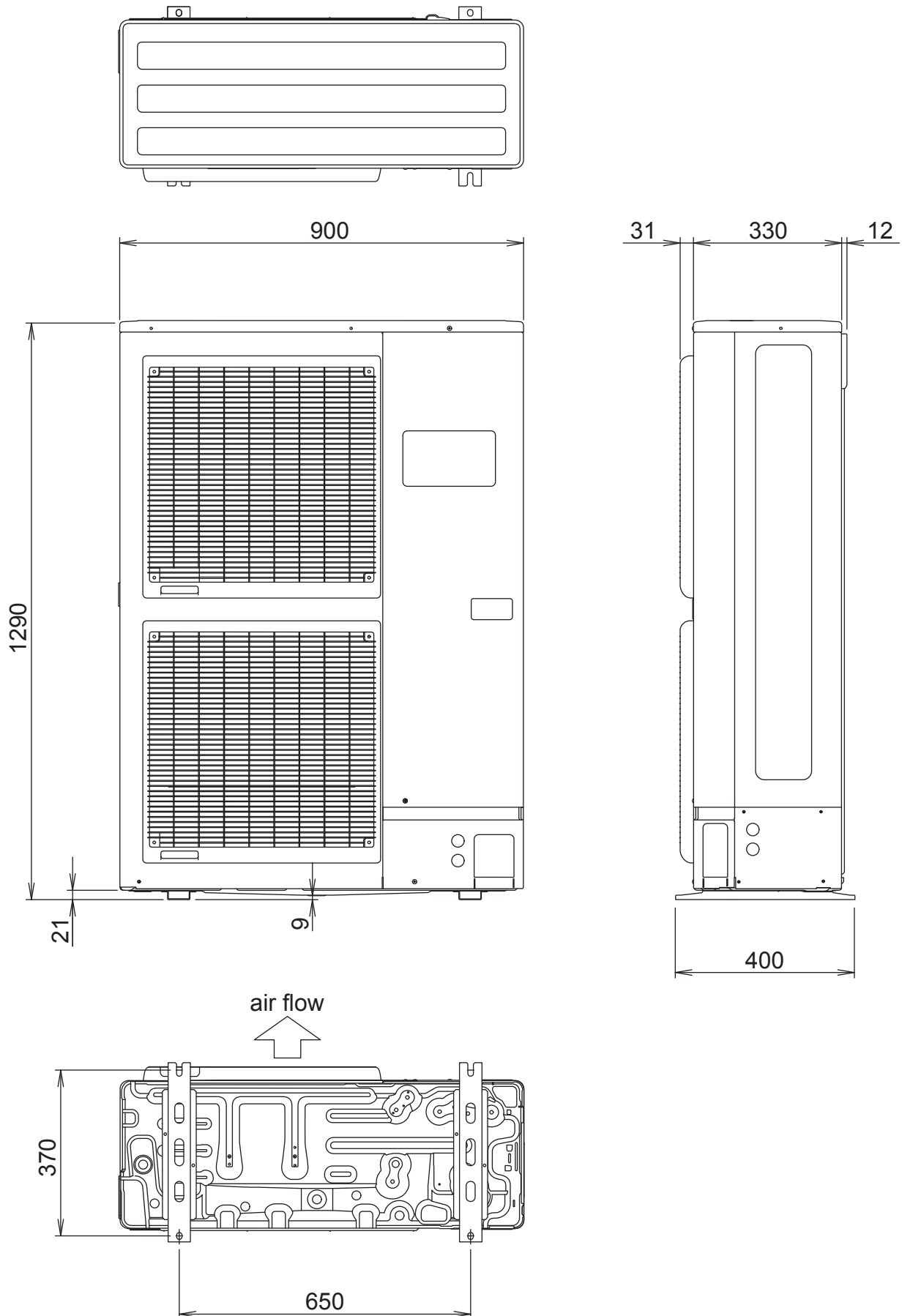

CIRCUIT DIAGRAM

INDOOR UNIT

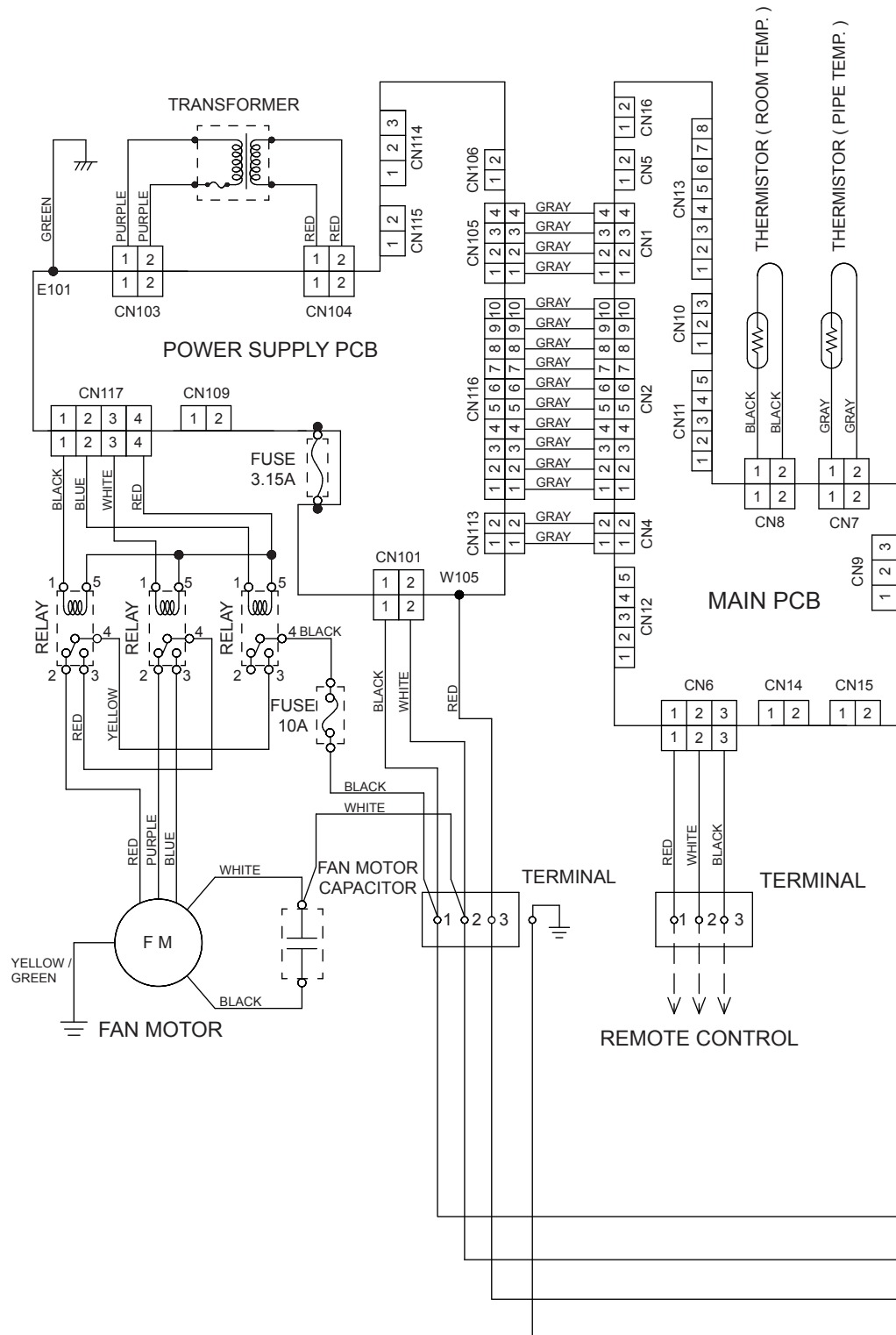

OUTDOOR UNIT

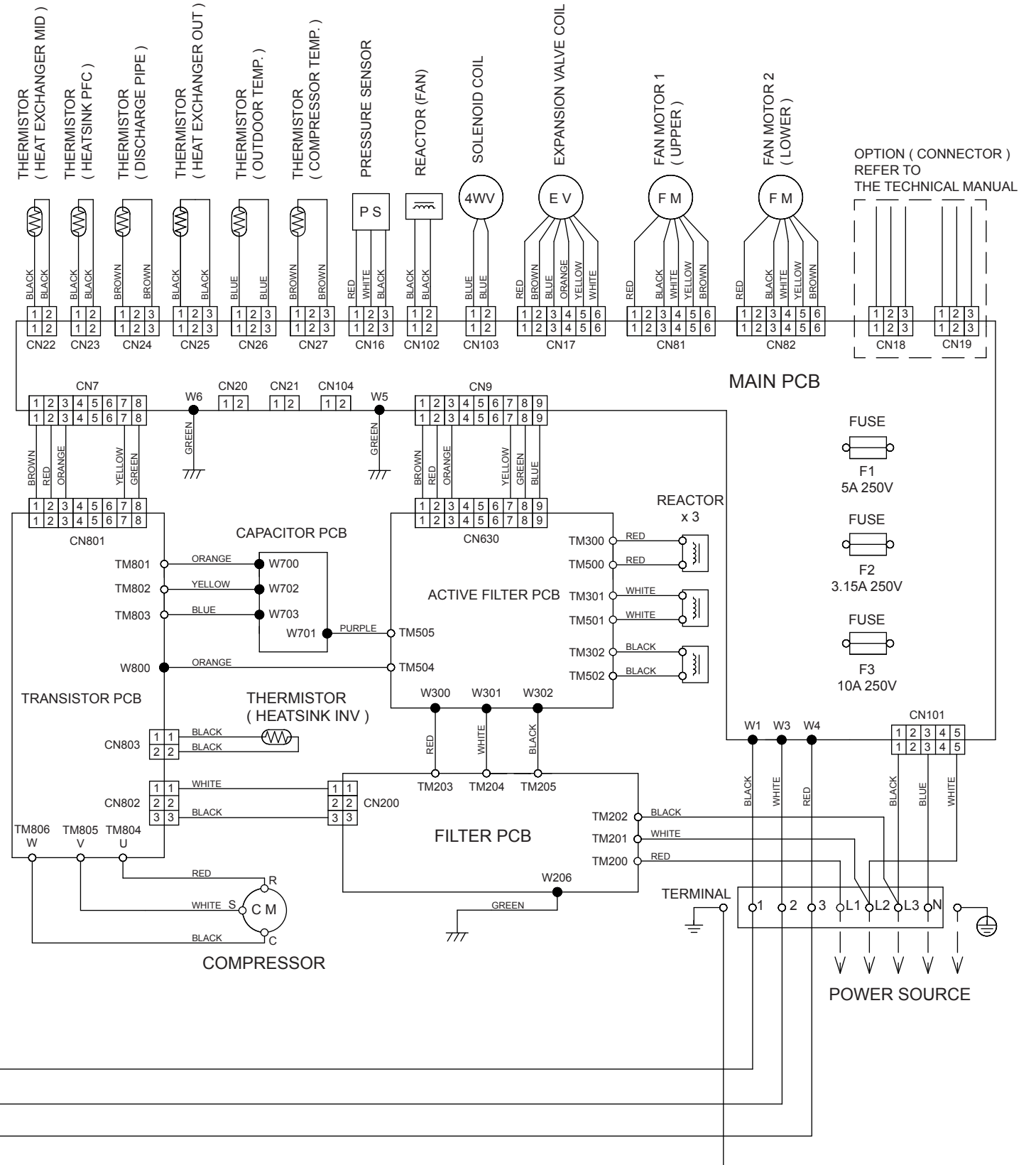

**POWER SUPPLY PCB
K04CW-1100HSE-P0**

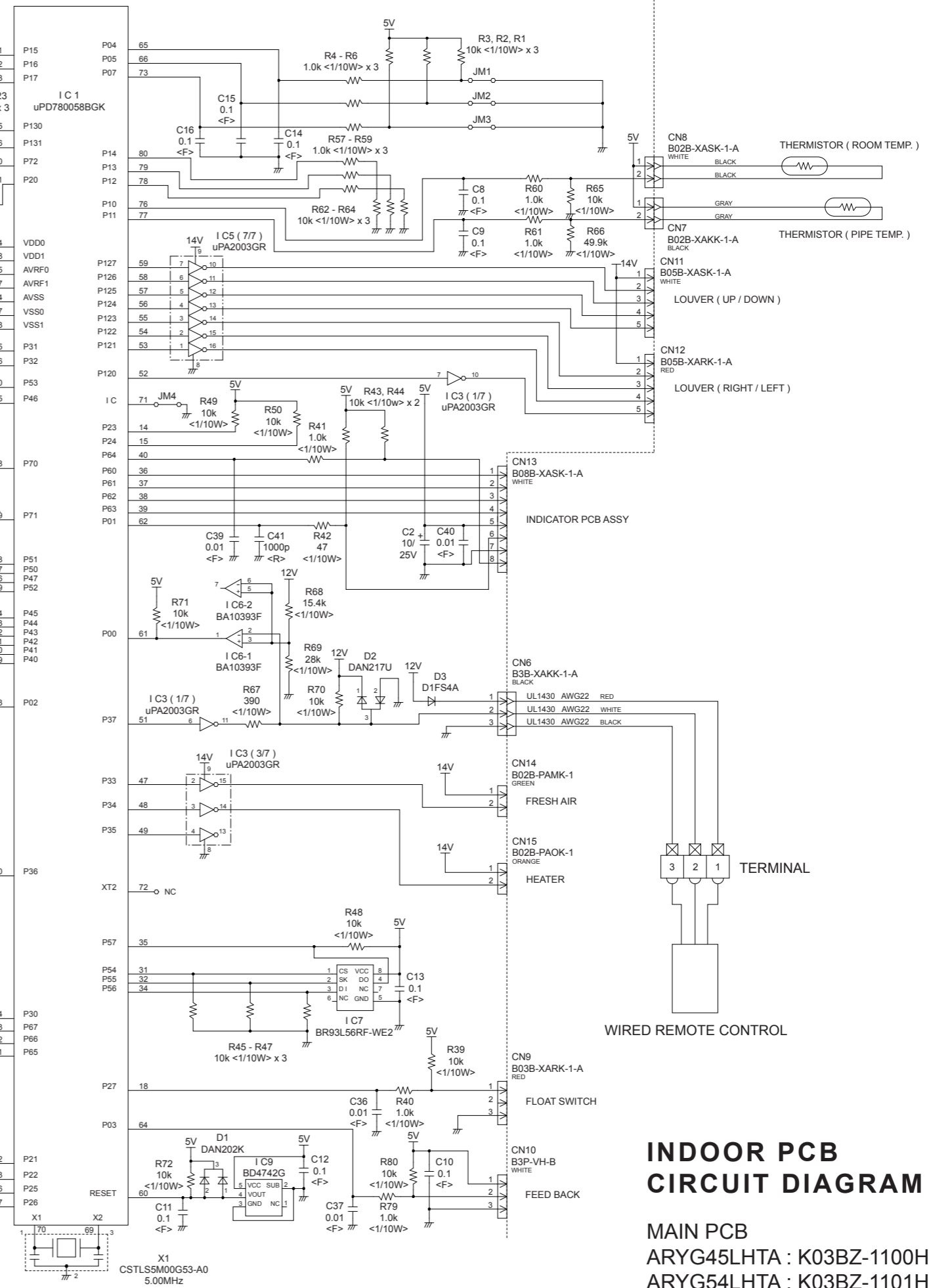
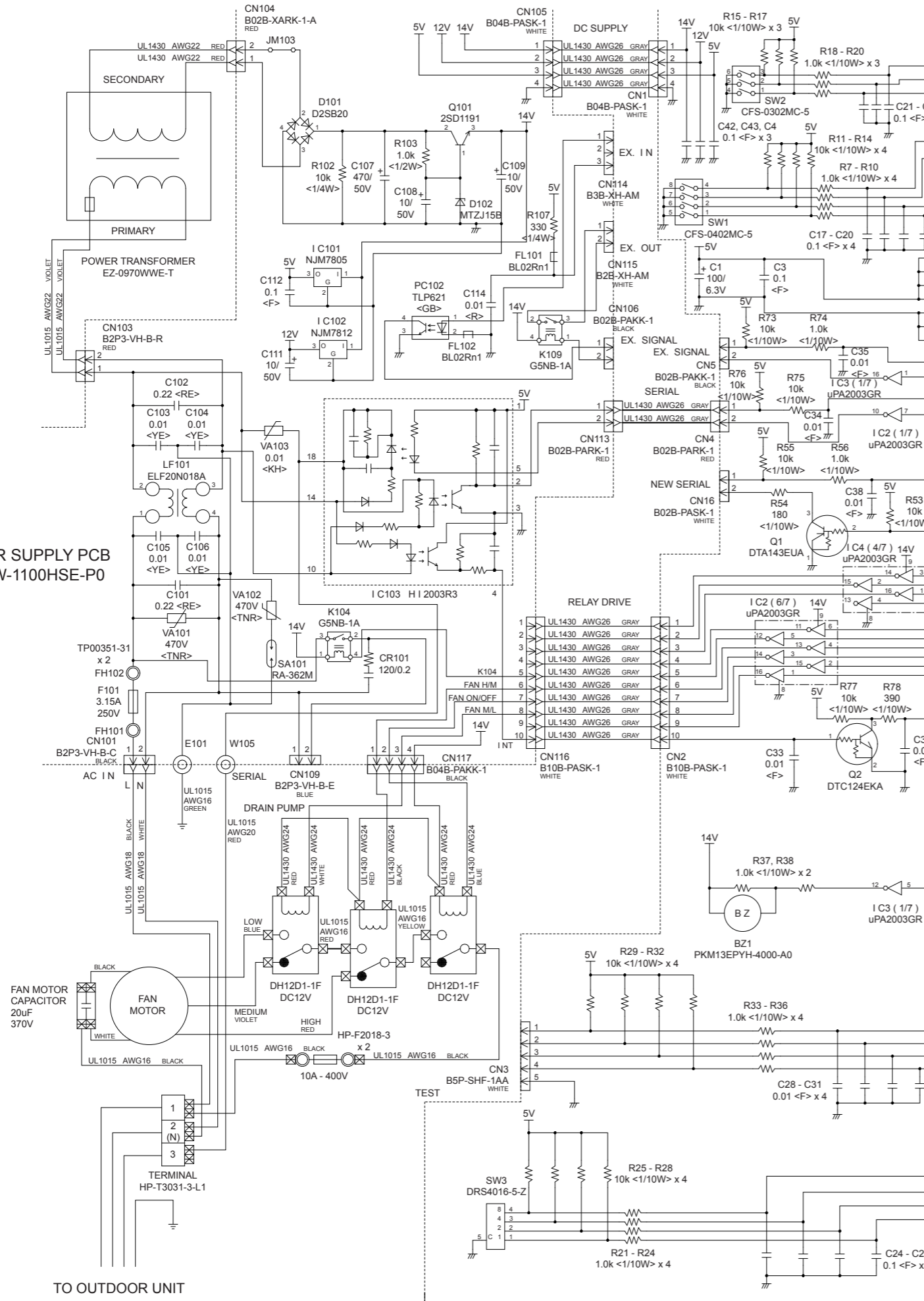

**INDOOR PCB
CIRCUIT DIAGRAM**

MAIN PCB
 ARYG45LHTA : K03BZ-1100HSE-C1
 ARYG54LHTA : K03BZ-1101HSE-C1

OUTDOOR PCB CIRCUIT DIAGRAM

INVERTER ASSEMBLY
AOYG45LATT : EZ-0111WHUE
AOYG54LATT : EZ-0111YHUE

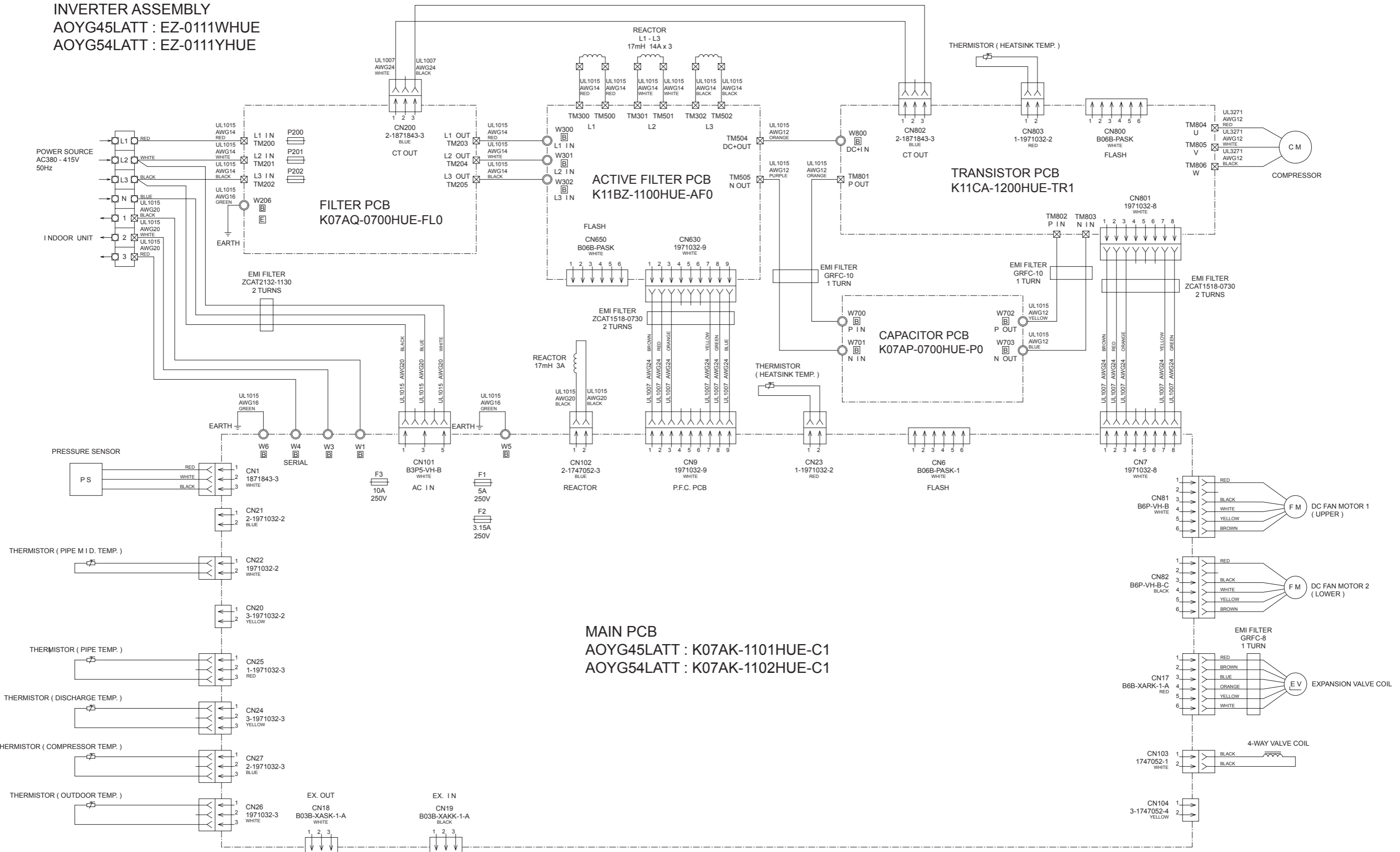

**OUTDOOR UNIT
MAIN PCB**
 AOYG45LATT : K07AK-1101HUE-C1
 AOYG54LATT : K07AK-1102HUE-C1

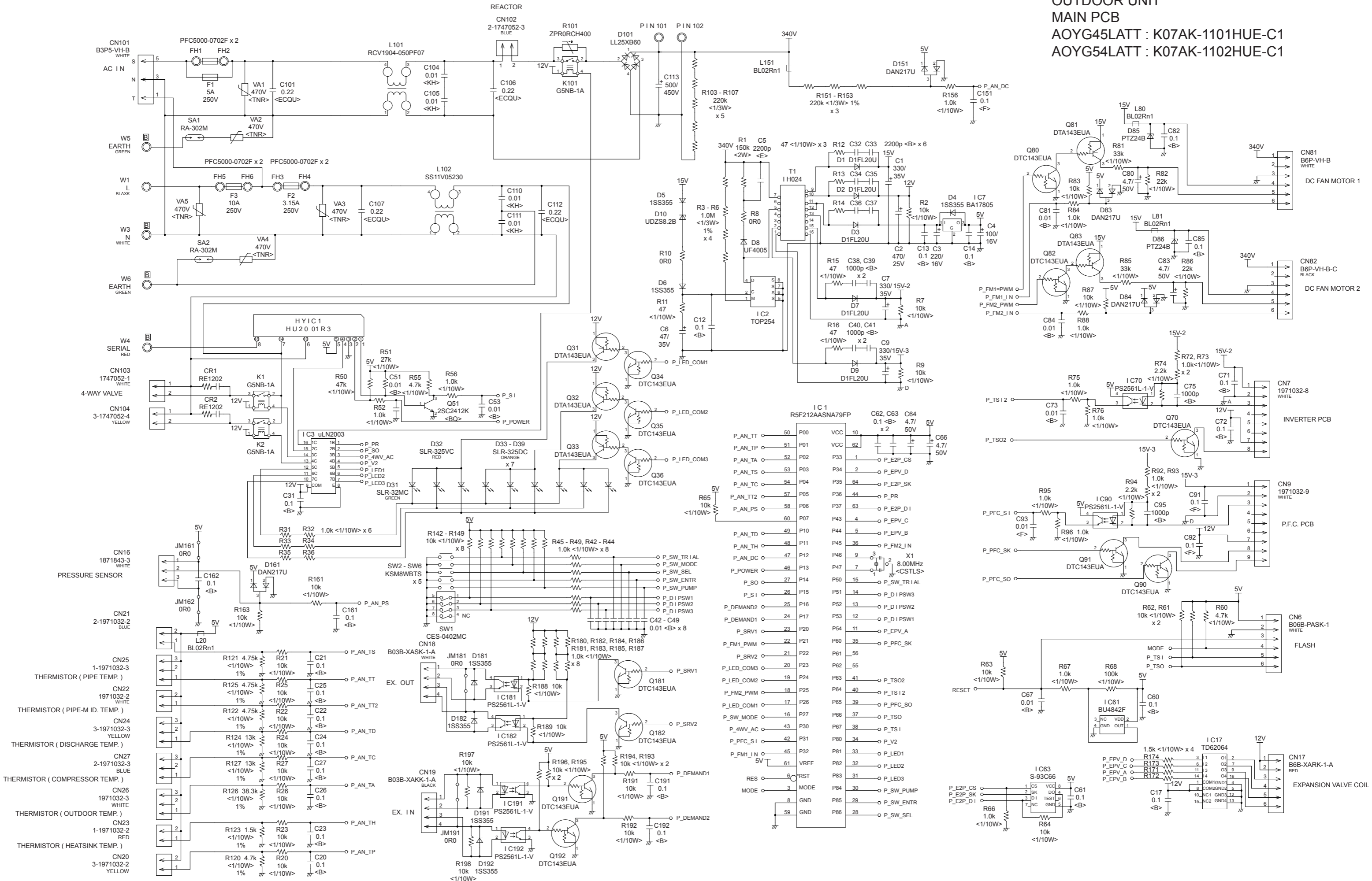

OUTDOOR UNIT
TRANSISTOR PCB
K11CA-1200HUE-TR1

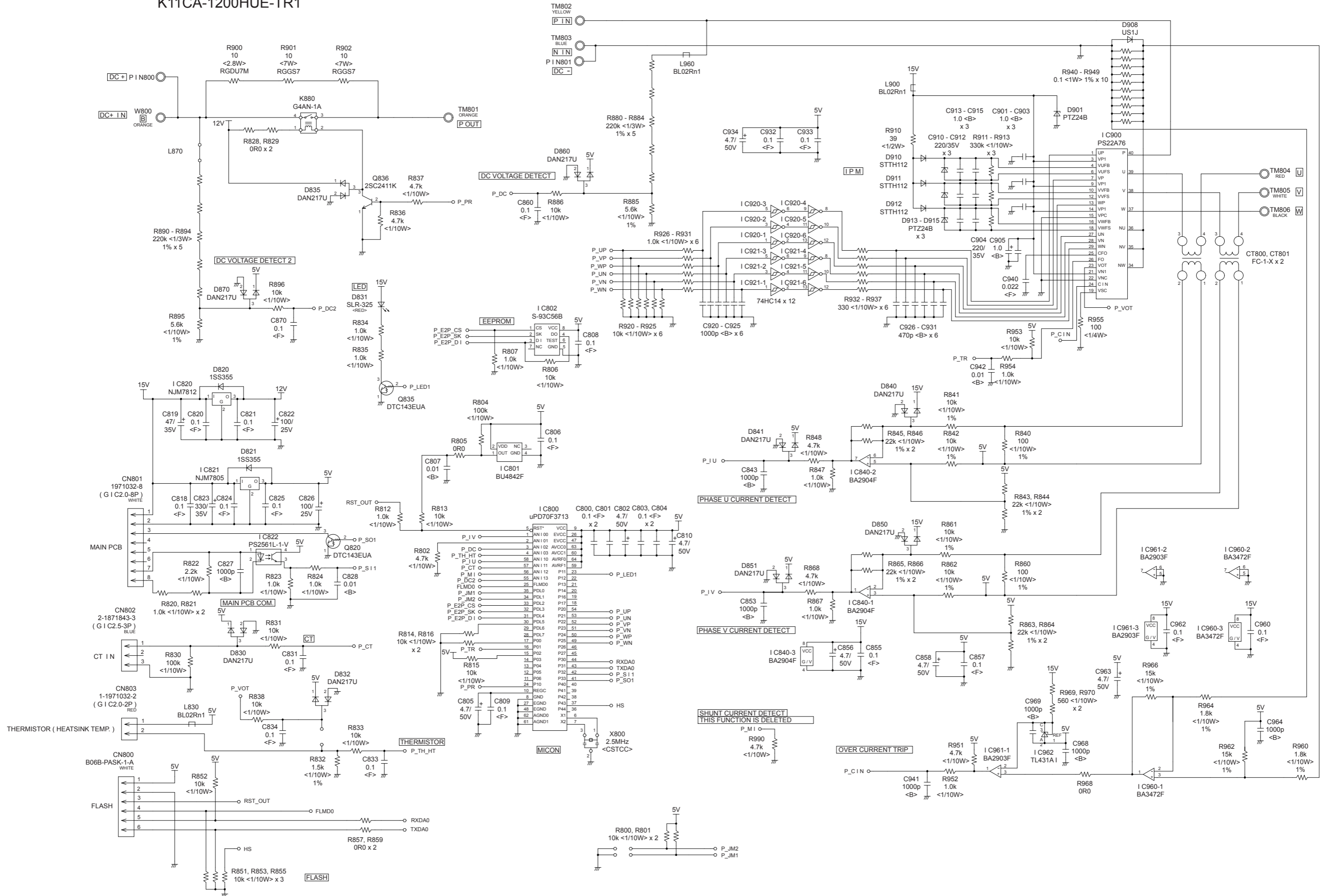

OUTDOOR UNIT FILTER PCB K07AQ-0700HUE-FL0

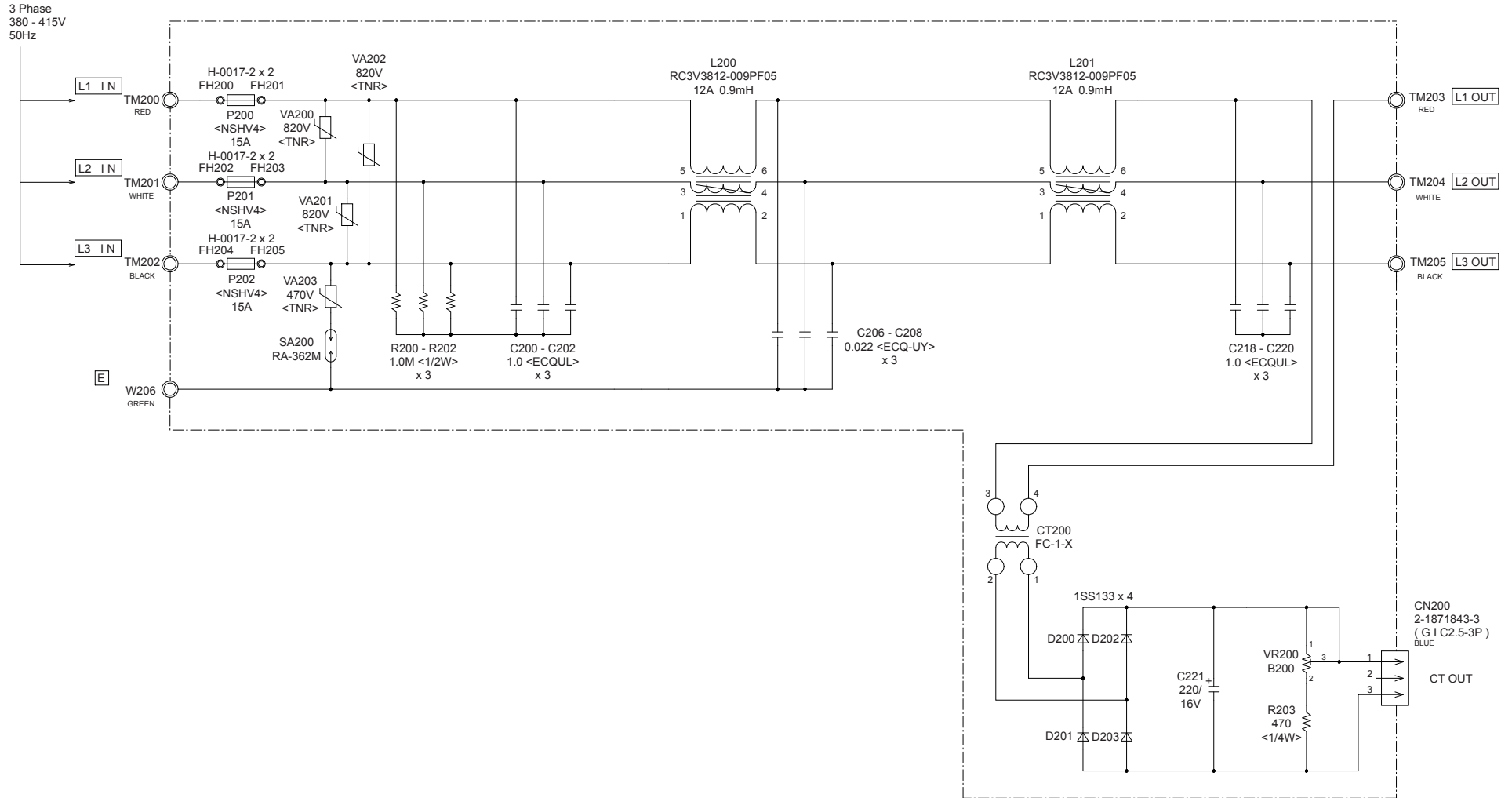

OUTDOOR UNIT
CAPACITOR PCB
K07AP-0700HUE-P0

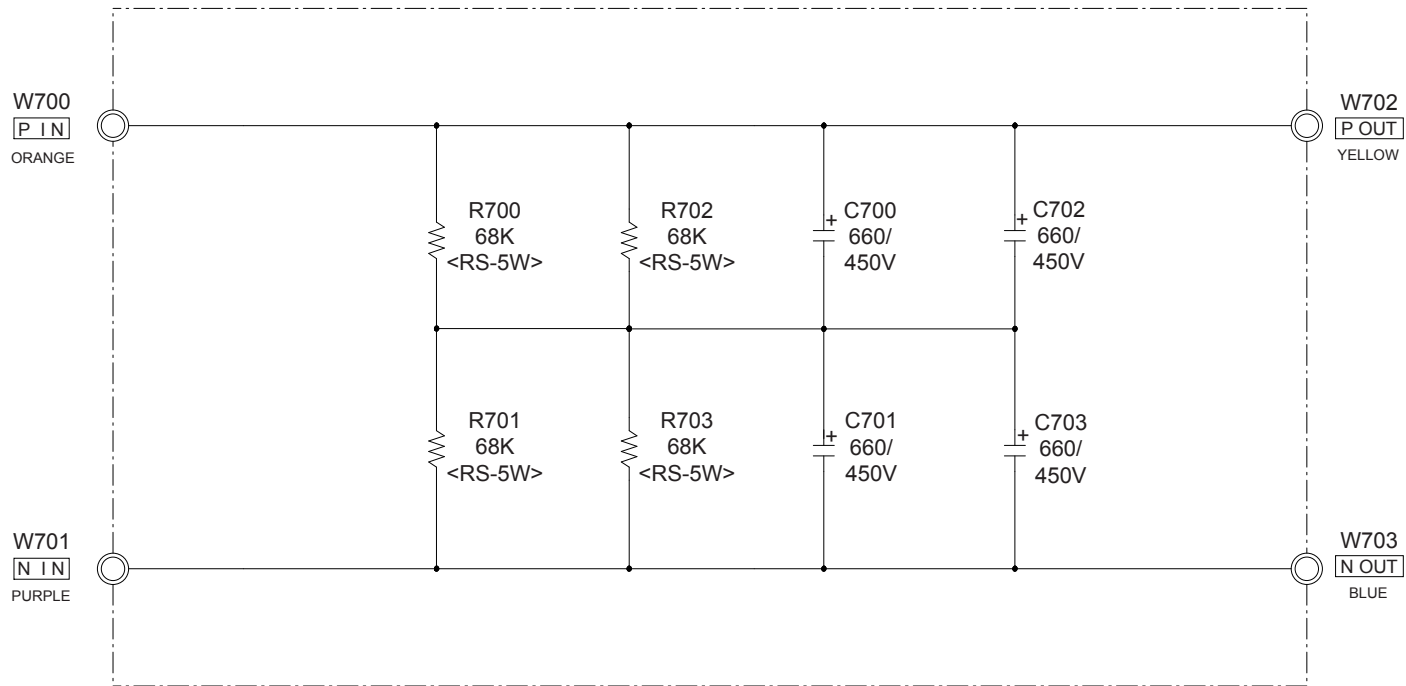

ERROR DETECTION

WIRED REMOTE CONTROL

This is possible only on a wired remote control.

If an error occurs, the following display will be shown.

("Er" will appear in the set room temperature display.)

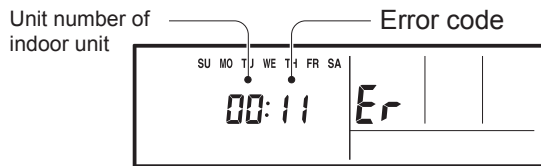

EX. Self-diagnosis

● : 0.5s on / 0.5s off

◇ : 0.1s on / 0.1s off

() : Number of flashing

Code	Description
11	Serial communication error
12	Wired remote control communication error
15	Check run unfinished
21	Unit number or Refrigerant circuit address setting error [Simultaneous Multi]
22	Indoor unit capacity error
23	Combination error
24	<ul style="list-style-type: none"> • Connection unit number error (indoor slave unit) [Simultaneous Multi] • Connection unit number error (indoor unit or branch unit) [Flexible Multi]
27	Master unit, slave unit set-up error [Simultaneous Multi]
31	Power supply interruption error
32	Indoor unit PCB model information error
35	Manual auto switch error
41	Room temp. sensor error
42	Indoor unit Heat Ex. Middle temp. sensor error
51	Indoor unit fan motor error
53	Drain pump error
57	Damper error
5U	Indoor unit error
62	Outdoor unit main PCB model information error or communication error
63	Inverter error
64	Active filter error, PFC circuit error
65	Trip terminal L error
6A	Display PCB microcomputers communication error

Code	Description
71	Discharge temp. sensor error
72	Compressor temp. sensor error
73	Outdoor unit Heat Ex. liquid temp. sensor error
74	Outdoor temp. sensor error
75	Suction gas temp. sensor error
76	<ul style="list-style-type: none"> • 2-way valve temp. sensor error • 3-way valve temp. sensor error
77	Heat sink temp. sensor error
82	<ul style="list-style-type: none"> • Sub-cool Heat Ex. gas inlet temp. sensor error • Sub-cool Heat Ex. gas outlet temp. sensor error
83	Liquid pipe temp. sensor error
84	Current sensor error
86	<ul style="list-style-type: none"> • Discharge pressure sensor error • Suction pressure sensor error • High pressure switch error
94	Trip detection
95	Compressor rotor position detection error (permanent stop)
97	Outdoor unit fan motor 1 error
98	Outdoor unit fan motor 2 error
99	4-way valve error
9A	Coil (expansion valve) error
A1	Discharge temp. error
A3	Compressor temp. error
A4	High pressure error
A5	Low pressure error
J2	Branch boxes error [Flexible Multi]

OUTDOOR UNIT

TEST RUN

⚠ CAUTION

Always turn on the power 6 hours prior to the start of the operation in order to protect the compressor.

1. Check items before performing the test run

Make sure to perform the test run.

Before performing the test run, be sure to check the following points.

- (1) Is gas leaking?
Check connection of each pipe (flare connection part, brazing part).
- (2) Is a breaker installed to the power cable of the outdoor unit ?
- (3) Has each cable been securely connected to the terminal according to the specifications ?
- (4) Are the 3-way valves (gas pipes and liquid pipes) of the outdoor units open?
- (5) Has the power been supplied to the unit for at least 6 hours ?
- (6) Has the necessary local setting been done ?
- (7) Check insulation resistance of 1 MΩ or more using a 500V mega tester.

If no problems are found with the above items, perform the test run according to "Test run method".

If any problems are found, immediately resolve the problem and re-check the items.

2. Test run method

⚠ CAUTION

If the test run is performed for 1 outdoor unit in a group control system installation, the test run will also be performed for the other units. Therefore, make sure that all of the units have been installed before starting a test run.
(Group control system installation described in "SPECIAL INSTALLATION METHODS" in the installation manual of the indoor unit.)

Operate [ENTER] (TEST RUN) switch on the display board by the following procedure.

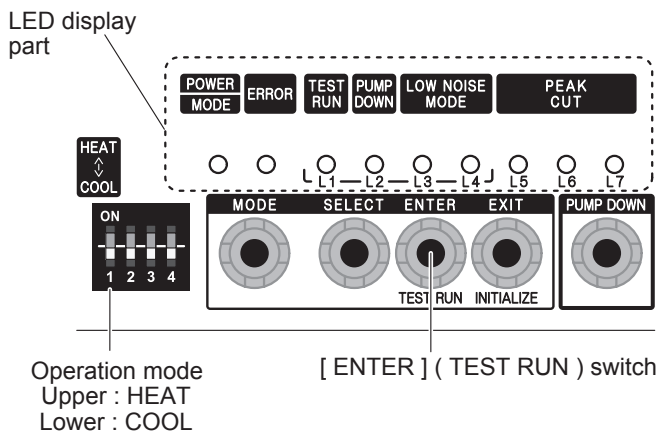

2.1. Operating procedures for the test run

- (1) Check the 3-way valves (both at the liquid side and gas side) are opened.
- (2) Set the operation mode to "COOL" or "HEAT".

POWER MODE	ERROR	TEST RUN (L1)	PUMP DOWN (L2)	LOW NOISE (L3) (L4)		PEAK CUT (L5) (L6) (L7)		
●	○	○	○	○	○	○	○	○

In the first test run, be sure to set the operation mode to "COOL".

The operation mode cannot be switched between "COOL" and "HEAT" during the test run. To switch the operation mode between "COOL" and "HEAT", stop the test run, switch the operation mode, and then start the test run again.

- (3) Press [ENTER] (TEST RUN) switch for more than 3 seconds.

POWER MODE	ERROR	TEST RUN (L1)	PUMP DOWN (L2)	LOW NOISE (L3) (L4)		PEAK CUT (L5) (L6) (L7)		
●	○	●	○	○	○	○	○	○

"TEST RUN" LED will light on.

If the compressor is operating at starting the test run, the compressor will stop and, after a while, the test run will start.

Either of the above "LOW NOISE" or "PEAK CUT" will light on during the test run if local setting function is selected.

- (4) Confirm operating status.
- (5) Press [ENTER] (TEST RUN) switch again.

POWER MODE	ERROR	TEST RUN (L1)	PUMP DOWN (L2)	LOW NOISE (L3) (L4)		PEAK CUT (L5) (L6) (L7)		
●	○	○	○	○	○	○	○	○

"TEST RUN" LED lights off, and TEST RUN stops.

Test run will finish after about 60 minutes automatically. At the same time, "TEST RUN" LED will light off.

Test run may be stopped before operating for 60 minutes if an error occurs after a starting test run.

OUTDOOR UNIT ERROR CODE DISPLAY

Display when an error occurs

POWER MODE	ERROR	TEST RUN (L1)	PUMP DOWN (L2)	LOW NOISE (L3) (L4)		PEAK CUT (L5) (L6) (L7)		
●	Blinks (Hi-speed)	○	○	○	○	○	○	○

Check that the ERROR LED blinks,
and then short-press the [ENTER] switch once.
The number of blinks of the LED indicates the type of error.

Display mode ● : ON
○ : OFF
◆ : Blink (0.5s ON / 0.5s OFF)
() : Number of flashing

Error code check table

POWER MODE	ERROR	TEST RUN (L1)	PUMP DOWN (L2)	LOW NOISE (L3) (L4)		PEAK CUT (L5) (L6) (L7)			Description
◆(2)	●	◆(1)	◆(1)	○	○	○	●	●	Serial forward transmission error immediately after operation
◆(2)	●	◆(1)	◆(1)	○	○	●	○	○	Serial forward transmission error during operation
◆(2)	●	◆(2)	◆(2)	○	○	○	○	●	Indoor unit capacity error
◆(2)	●	◆(5)	◆(15)	○	○	○	○	●	Indoor unit error
◆(2)	●	◆(6)	◆(1)	○	○	○	○	●	Over voltage
◆(2)	●	◆(6)	◆(1)	○	○	○	●	●	Power supply frequency error
◆(2)	●	◆(6)	◆(2)	○	○	○	○	●	Outdoor unit PCB model information error
◆(2)	●	◆(6)	◆(2)	○	○	●	●	○	Inverter communication error
◆(2)	●	◆(6)	◆(2)	○	○	●	●	●	PFC communication error
◆(2)	●	◆(6)	◆(3)	○	○	○	○	●	Inverter error
◆(2)	●	◆(6)	◆(4)	○	○	●	●	●	PFC AD detection error
◆(2)	●	◆(6)	◆(4)	○	●	○	○	○	PFC hardware error
◆(2)	●	◆(6)	◆(5)	○	○	○	●	●	IPM error (Trip terminal L error)
◆(2)	●	◆(6)	◆(8)	○	○	○	●	○	Rush current limiting resistor temp rise protection
◆(2)	●	◆(7)	◆(1)	○	○	○	○	●	Discharge temp. sensor error
◆(2)	●	◆(7)	◆(2)	○	○	○	○	●	Compressor temp. sensor error
◆(2)	●	◆(7)	◆(3)	○	○	○	●	○	Heat Ex. middle temp. sensor error
◆(2)	●	◆(7)	◆(3)	○	○	○	●	●	Outdoor unit Heat Ex. liquid temp. sensor error
◆(2)	●	◆(7)	◆(4)	○	○	○	○	●	Outdoor temp. sensor error
◆(2)	●	◆(7)	◆(7)	○	○	○	○	●	Heat sink temp. sensor error
◆(2)	●	◆(7)	◆(7)	○	○	○	●	○	PFC heat sink temp. sensor error
◆(2)	●	◆(8)	◆(4)	○	○	○	○	●	Current sensor 1 error (stoppage permanently)
◆(2)	●	◆(8)	◆(6)	○	○	●	○	○	High pressure switch 1 error
◆(2)	●	◆(8)	◆(6)	○	○	●	●	○	Pressure sensor error
◆(2)	●	◆(9)	◆(4)	○	○	○	○	●	Trip detection (stoppage permanently)
◆(2)	●	◆(9)	◆(5)	○	○	○	○	●	Compressor motor control error (stoppage permanently)
◆(2)	●	◆(9)	◆(5)	○	○	●	○	●	Compressor motor loss of synchronization (stoppage permanently)
◆(2)	●	◆(9)	◆(7)	○	○	○	●	●	Outdoor unit fan motor 1 error (Duty error)
◆(2)	●	◆(9)	◆(8)	○	○	○	●	●	Outdoor unit fan motor 2 error (Duty error)
◆(2)	●	◆(9)	◆(9)	○	○	○	○	●	4-way valve error
◆(2)	●	◆(10)	◆(1)	○	○	○	○	●	Discharge temp. 1 error (stoppage permanently)
◆(2)	●	◆(10)	◆(3)	○	○	○	○	●	Compressor 1 temp. error (stoppage permanently)
◆(2)	●	◆(10)	◆(5)	○	○	○	○	●	Low pressure error

OUTDOOR UNIT

PUMP DOWN (Refrigerant collecting operation)

Perform the following procedures to collect the refrigerant when moving the indoor unit or outdoor unit

WARNING
Never touch electrical components such as the terminal blocks or reactor except the switch on the display board. It may cause a serious accident such as electric shock.

CAUTION
Perform the pump down operation before disconnecting any refrigerant pipe or electric cable.

Collect refrigerant from the service port or the 3-way valve if pump down cannot be performed.

In case of a group control system installation, do not turn the power off pump down is completed in all outdoor units.
(Group control system installation described in "SPECIAL INSTALLATION METHODS" in the installation manual of the indoor unit.)

Operate [PUMP DOWN] switch on the display board in the manner described below.

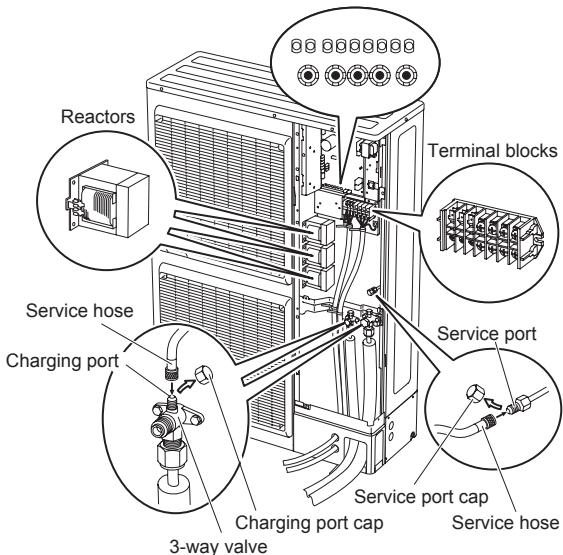
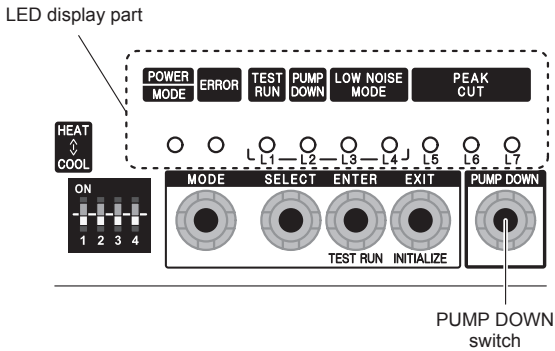

1. Preparation for pump down

Confirm that the power is off, and then open the service panel.

2. Pump down procedure

- (1) Check the 3-way valves (both at the liquid side and gas side) are opened.
- (2) Turn the power on.

POWER	ERROR	TEST RUN (L1)	PUMP DOWN (L2)	LOW NOISE (L3)	(L4)	PEAK CUT (L5) (L6) (L7)		
MODE								
●	○	○	○	○	○	○	○	○

- (3) Press [PUMP DOWN] switch for 3 seconds or more after 3 minutes after power on.

POWER	ERROR	TEST RUN (L1)	PUMP DOWN (L2)	LOW NOISE (L3)	(L4)	PEAK CUT (L5) (L6) (L7)		
MODE								
●	○	○	●	○	○	●	●	●

LED display lights on as shown in the above figure, and the fans and the compressor start operating.

If the [PUMP DOWN] switch is pressed while the compressor is operating, the compressor will stop, then start again in about 3 minutes.

- (4) LED display will change as shown below about 3 minutes after the compressor starts. Fully close the 3-way valve on the liquid pipe side at this stage.

POWER	ERROR	TEST RUN (L1)	PUMP DOWN (L2)	LOW NOISE (L3)	(L4)	PEAK CUT (L5) (L6) (L7)		
MODE								
●	○	○	●	○	○	○	●	●

If the valve on the liquid pipe side is not closed, the pump down cannot be performed.

- (5) When LED display changes as shown in the below figure, close the 3-way valve on the gas pipe side tightly.

POWER	ERROR	TEST RUN (L1)	PUMP DOWN (L2)	LOW NOISE (L3)	(L4)	PEAK CUT (L5) (L6) (L7)		
MODE								
●	○	○	●	○	○	○	○	●

If the valve on the gas pipe side is not closed, refrigerant may flow into the piping after the compressor stops

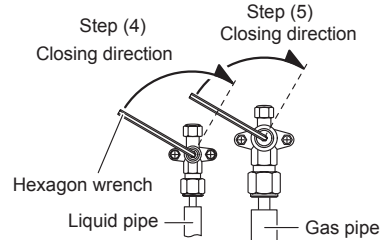

- (6) LED display changes after 1 minute as shown in the figure below

POWER	ERROR	TEST RUN (L1)	PUMP DOWN (L2)	LOW NOISE (L3)	(L4)	PEAK CUT (L5) (L6) (L7)		
MODE								
●	○	○	●	○	○	○	○	○

Fans and compressor stop automatically.

If the pump down is successfully completed (the above LED display is shown), the outdoor unit remains stopped until the power is turned off.

- (7) Turn the power off.

POWER	ERROR	TEST RUN (L1)	PUMP DOWN (L2)	LOW NOISE (L3)	(L4)	PEAK CUT (L5) (L6) (L7)		
MODE								
○	○	○	○	○	○	○	○	○

PUMP DOWN is completed.

(Note)

To stop pump down, press the [PUMP DOWN] switch again.

To start the pump down again after the compressor is automatically stopped due to an error, turn the power off and open the 3-way valves. Wait 3 minutes, turn the power on and start the pump down again.

When starting the operation after completion of the pump down, turn the power off, and then open the 3-way valves. Wait 3 minutes, turn the power on and perform a test run in the "COOL" operation mode.

PARTS

INDOOR UNIT

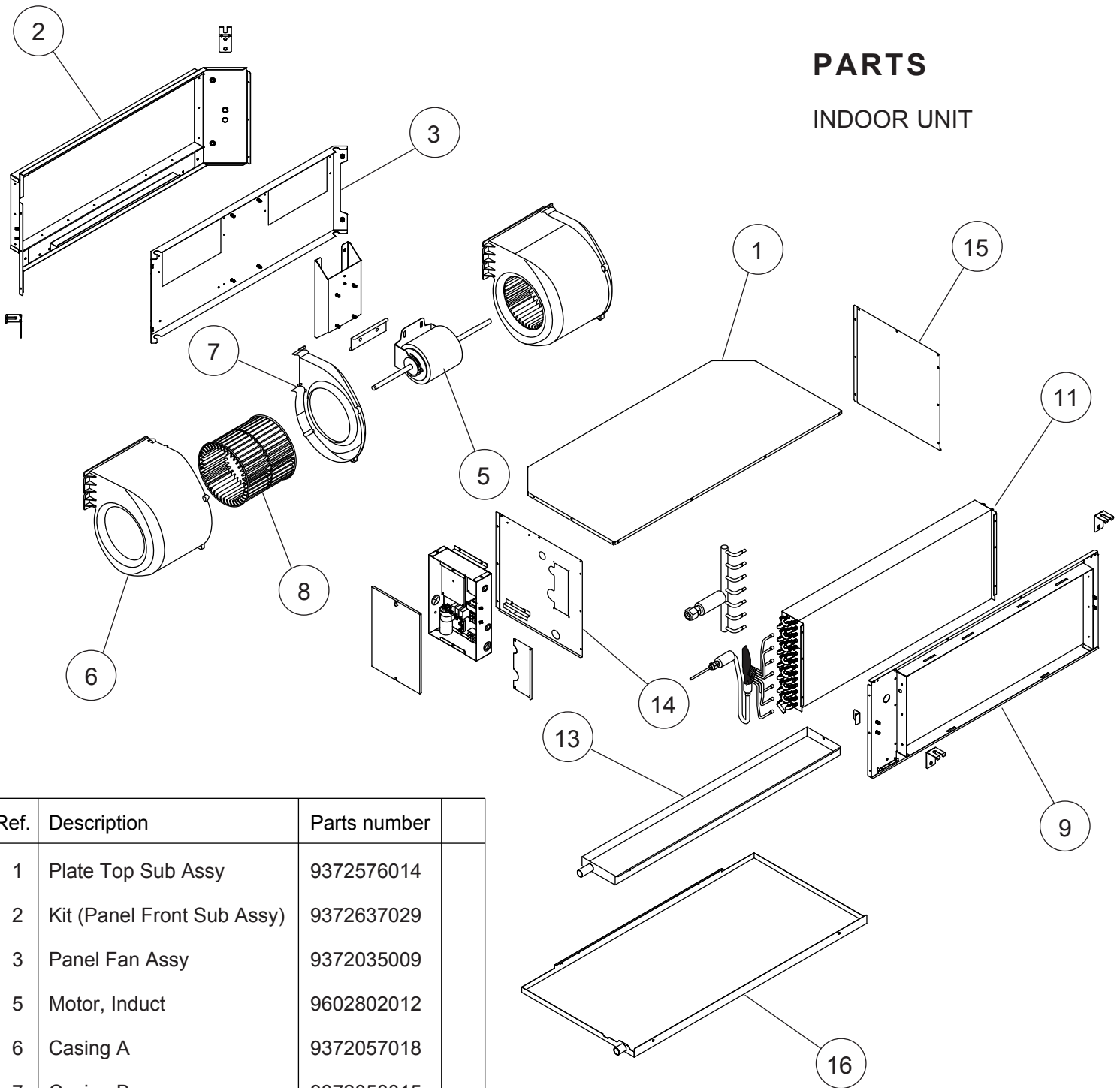

Ref.	Description	Parts number
1	Plate Top Sub Assy	9372576014
2	Kit (Panel Front Sub Assy)	9372637029
3	Panel Fan Assy	9372035009
5	Motor, Induct	9602802012
6	Casing A	9372057018
7	Casing B	9372058015
8	Sirocco Fan	9372059029
9	Kit (Panel Rear Sub Assy)	9372636022
10	Room Thermistor	9703299216
11	Evaporator Sub Assy	9372584057
12	Pipe Thermistor	9703297113
13	Drain Pan Assy	9372579015
14	Kit (Panel Right Sub Assy)	9372916025
15	Kit (Panel Left Sub Assy)	9372581018
16	Drain Pan S Sub Assy	9372582015

(Connector : white) (Connector : black)

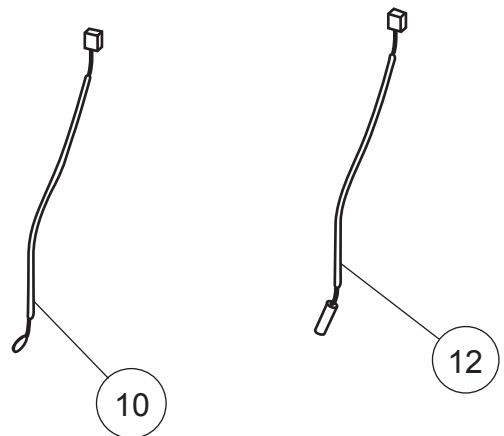

INDOOR UNIT

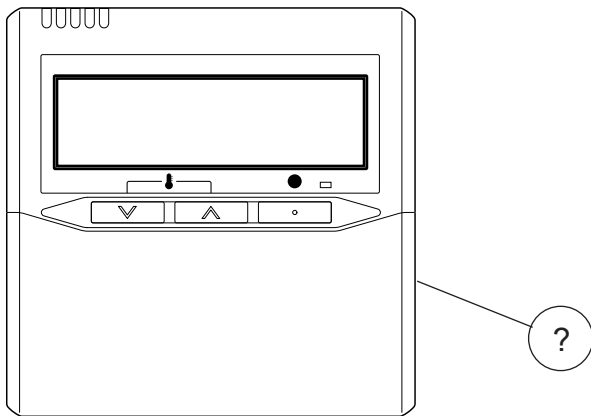
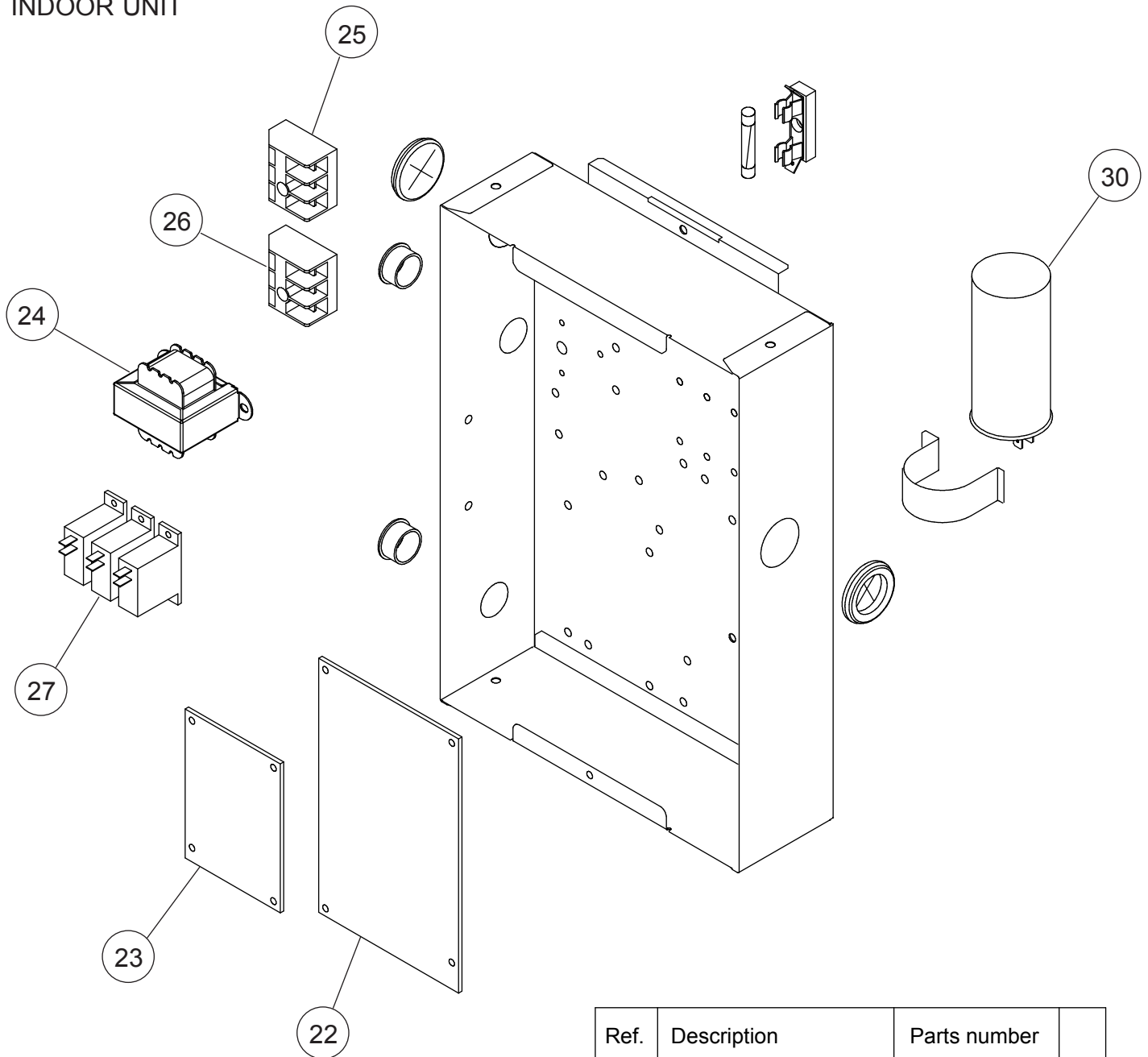

Ref.	Description	Parts number
22	Power Supply PCB	9705668119
23	Main PCB (45)	9705246287
23	Main PCB (54)	9705246294
24	Transformer (Power)	9704129017
25	Terminal 3P	9703345012
26	Terminal 3P	9306489045
27	Relay	9900294014
30	Capacitor, Plastic	9900269111
?	Remote Control	9318593013

PARTS

OUTDOOR UNIT

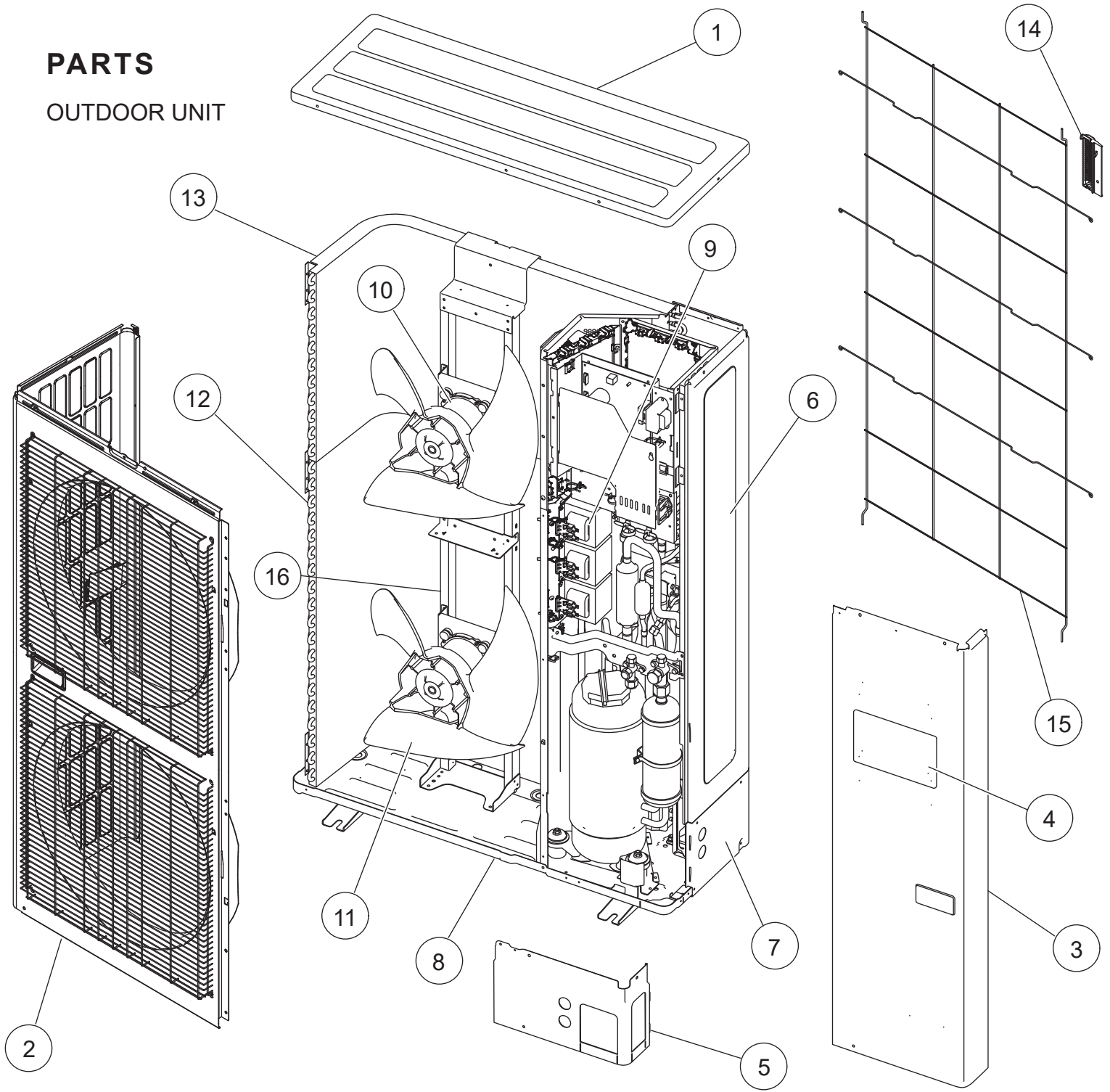

Ref.	Description	Parts number
1	Top Panel Sub Assy	9374417032
2	Front Panel Sub Assy	9374414130
3	Sevice Panel Sub Assy	9374415076
4	Emblem Rear	9351355005
5	Pipe Cover Front	9378861015
6	Right Panel	9378863019
7	Pipe Cover Rear	9378862012
8	Base Assy	9374166220

Ref.	Description	Parts number
9	Reactor Assy	9900641016
10	Motor, DC Brushless	9602843046
11	Propeller Fan Assy	9366378020
12	Condenser A Sub Assy	9374420261
13	Condenser B Sub Assy	9374422081
14	Thermo Holder	9375211011
15	Protective Net	9375381042
16	Motor Bracket Sub Assy	9374418145

OUTDOOR UNIT

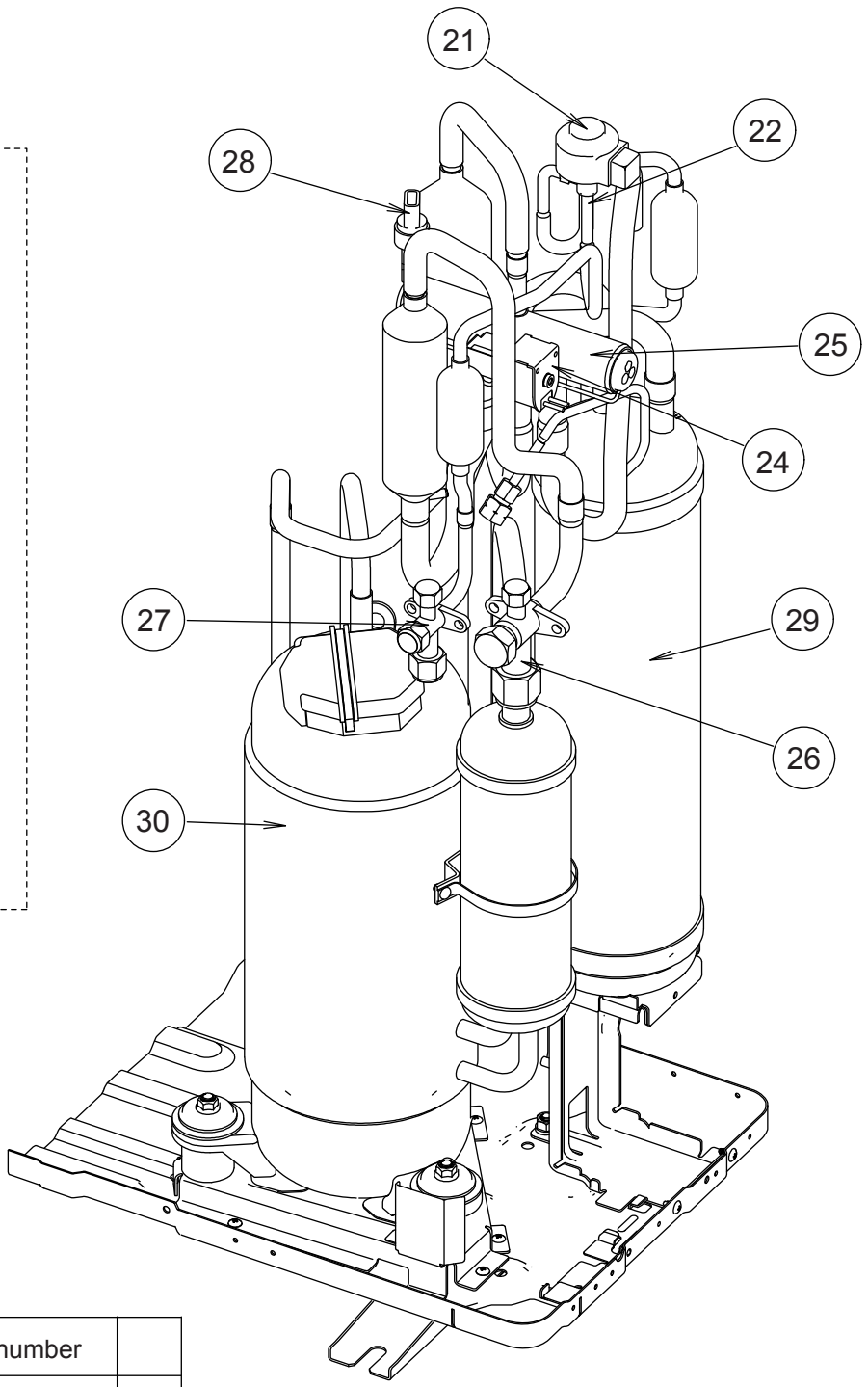
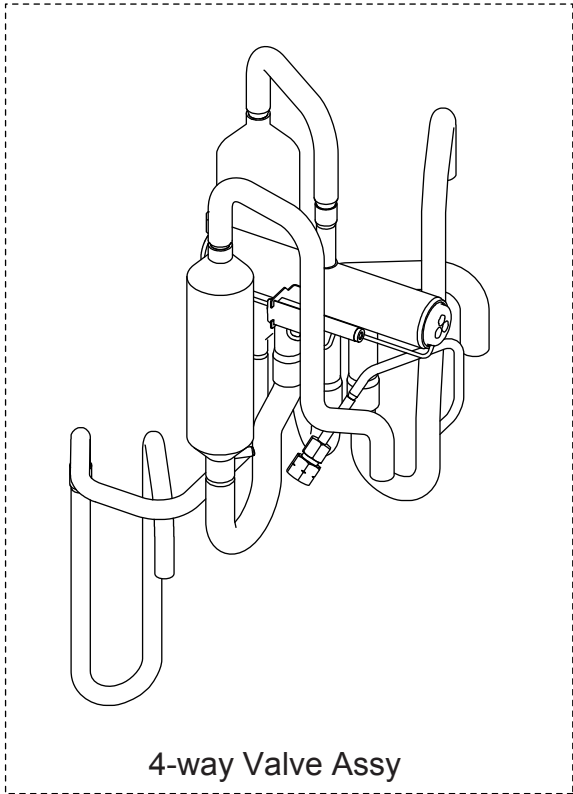

Ref.	Description	Parts number	
21	Expansion Valve Coil	9900190057	
22	Expansion Valve Assy	9370947182	
23	Strainer Assy	9372524039	
24	Solenoid	9970113024	
25	4-way Valve Assy	9374425273	
26	3-way Valve Assy	9379079006	
27	3-way Valve Assy	9379077002	
28	Sensor	9900505011	
29	Accumulator Assy	9375250096	
30	Compressor Assy	9383162008	

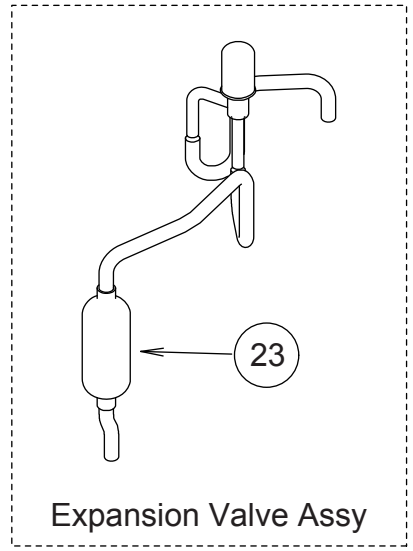



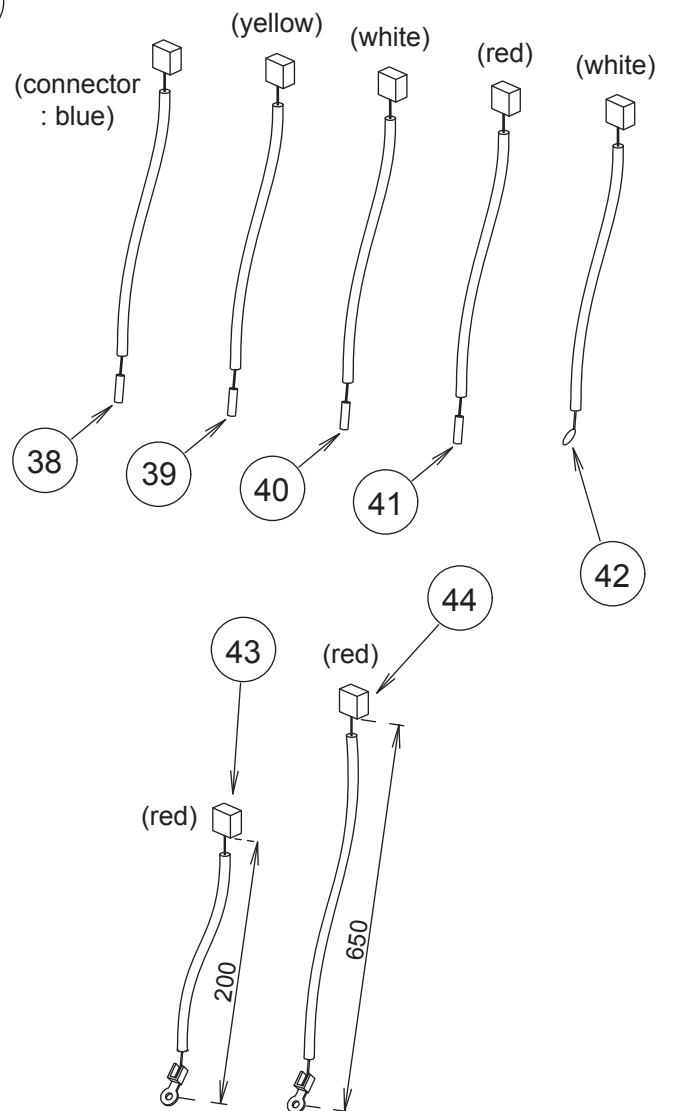
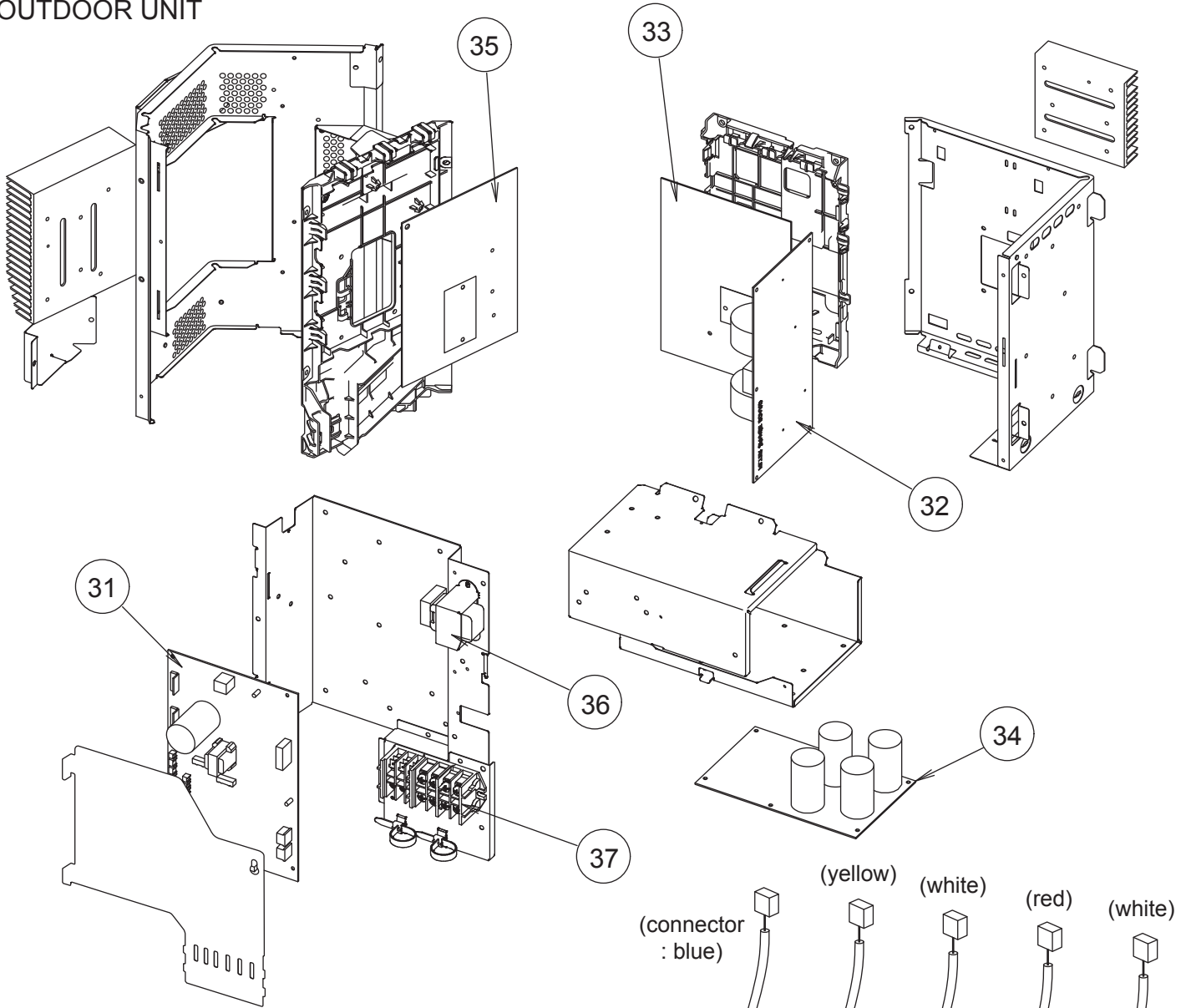



OUTDOOR UNIT



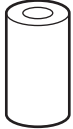
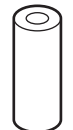

Ref.	Description	Parts number
31	Main PCB (45)	9707627077
31	Main PCB (54)	9707627084
32	Filter PCB	9707609011
33	Active Filter PCB with grease	9709680438
34	Capacitor PCB	9707608014
35	Transistor PCB with grease	9709680445
36	Reactor Assy	9900481018
37	Terminal	9900428082
38	Compressor Thermistor	9900516000
39	Discharge Thermistor	9900515003
40	Thermistor (Heat Exchanger Mid)	9900513009
41	Thermistor (Heat Exchanger Out)	9900514006
42	Outdoor Thermistor	9900517007
43	Heatsink Thermistor (Inverter)	9900518011
44	Heatsink Thermistor (PFC)	9900518028

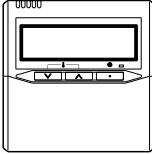
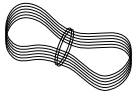
ACCESSORIES

INDOOR UNIT

Name and Shape	Q'ty	Application	Part number
Special nut A (large flange) 	4	For suspending the indoor unit from ceiling	313005446653
Special nut B (small flange) 	4		313005446759
Coupler heat insulation (large) 	1	For indoor side pipe joint (large pipe)	9378173569
Coupler heat insulation (small) 	1	For indoor side pipe joint (small pipe)	9378173521
Cable tie 	1	Fixing the remote cord	313361275805
Remote control 	1	For air conditioner operation	9318593013
Remote control cord 	1	For connecting the remote control	9372714010
Tapping screw (ø4 × 16) 	2	For installing the remote control	0700181108

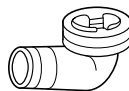
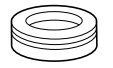
OUTDOOR UNIT

Name and Shape	Q'ty	Application	Part number
Drain pipe 	1	For drain piping work	9303029015
Drain cap 	2		313166024302
One-touch bush 	2	For power supply cable and connection cable installation	9378779013

OPTIONAL PARTS

Parts name	Model No.	Application
Simple remote control	UTY-RSNYM	For air conditioner operation
Wired remote control	UTY-RNNYM	For air conditioner operation
Remote sensor unit	UTY-XSZX	Room temperature sensor
External connect kit	UTD-ECS5A	For control input/output port
Long life filter	UTD-LF60KA	

1204G4043