

SPLIT TYPE
ROOM AIR CONDITIONER
WALL MOUNTED TYPE

SERVICE MANUAL

Indoor unit Outdoor unit
ASYG24LFCC AOYG24LFCC



CONTENTS

SPECIFICATIONS.....	1
DIMENSIONS.....	2
REFRIGERANT SYSTEM DIAGRAM.....	3
CIRCUIT DIAGRAM.....	4
INDOOR PCB CIRCUIT DIAGRAM.....	5
OUTDOOR PCB CIRCUIT DIAGRAM.....	8
ERROR DETECTION.....	10
PARTS (INDOOR UNIT).....	11
PARTS (OUTDOOR UNIT).....	15
ACCESSORIES.....	18

SPECIFICATIONS

ELECTRICAL DATA

TYPE		Cool & heat inverter
INDOOR UNIT		ASYG24LFCC
OUTDOOR UNIT		AOYG24LFCC
COOLING CAPACITY		7.10 kW
HEATING CAPACITY		8.00 kW
POWER SOURCE		230 V
FREQUENCY		50 Hz
RUNNING CURRENT	COOLING	9.7 A
	HEATING	9.7 A
INPUT WATTS	COOLING	2.20 kW
	HEATING	2.21 kW
E.E.R.	COOLING	3.23 kW/kW
COP	HEATING	3.61 kW/kW
MOISTURE REMOVAL		2.7 L/hr
AIR CIRCULATION HIGH		1,120 m ³ /hr
MAXIMUM CURRENT	COOLING	13.5 A
	HEATING	18.5 A

FAN MOTOR

POWER SOURCE		230 V
INDOOR UNIT (Cool)	High	1,480 r.p.m.
	Medium	1,220 r.p.m.
	Low	1,020 r.p.m.
	Quiet	860 r.p.m.
INDOOR UNIT (Heat)	High	1,480 r.p.m.
	Medium	1,220 r.p.m.
	Low	1,020 r.p.m.
	Quiet	860 r.p.m.
OUTDOOR UNIT (Cool)		1,100 r.p.m.
OUTDOOR UNIT (Heat)		1,050 r.p.m.

NOISE LEVEL

INDOOR UNIT (Cool)	High	49 dB
	Medium	42 dB
	Low	37 dB
	Quiet	32 dB
INDOOR UNIT (Heat)	High	48 dB
	Medium	42 dB
	Low	37 dB
	Quiet	32 dB
OUTDOOR UNIT (Cool)		55 dB
OUTDOOR UNIT (Heat)		56 dB

COMPRESSOR AND REFRIGERANT

TYPE		Hermetic type, 6 pole, Rotary
DISCRIMINATION		N-SF17ND1A
WEIGHT WITH OIL		10.6 kg
PRECHARGED REFRIGERANT		1,800 g
REFRIGERANT TYPE		R410A
FULL CHARGE	Pipe length 15 m	1,800 g
	30 m	2,100 g
ADDITIONAL CHARGE		20 g/m
MAXIMUM HEIGHT DIFFERENCE		20 m

DIMENSIONS

INDOOR UNIT	H x W x D	320 x 998 x 238 mm
OUTDOOR UNIT	H x W x D	620 x 790 x 290 mm

WEIGHT

INDOOR UNIT	Shipping / Net	18 kg / 14 kg
OUTDOOR UNIT	Shipping / Net	45 kg / 41 kg

DIMENSIONS

Unit : mm

INDOOR UNIT

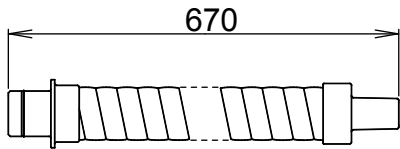
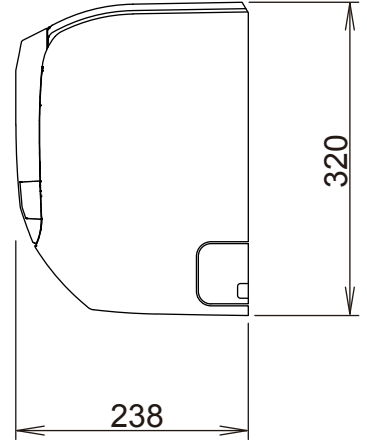
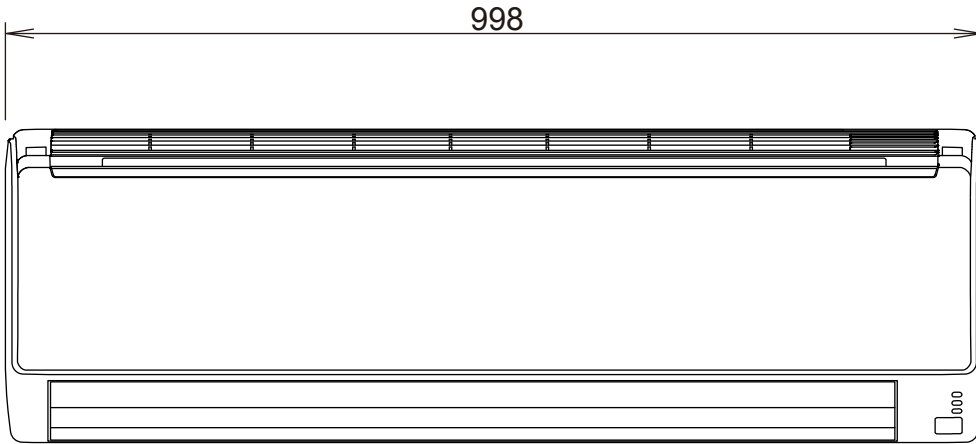

Drain hose length : 670 mm
Drain hose diameter
Inside : 12 mm
Outside : 16 mm

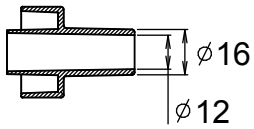

OUTDOOR UNIT

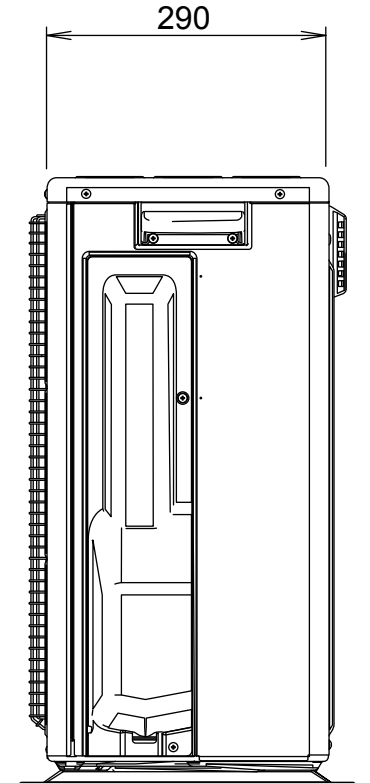
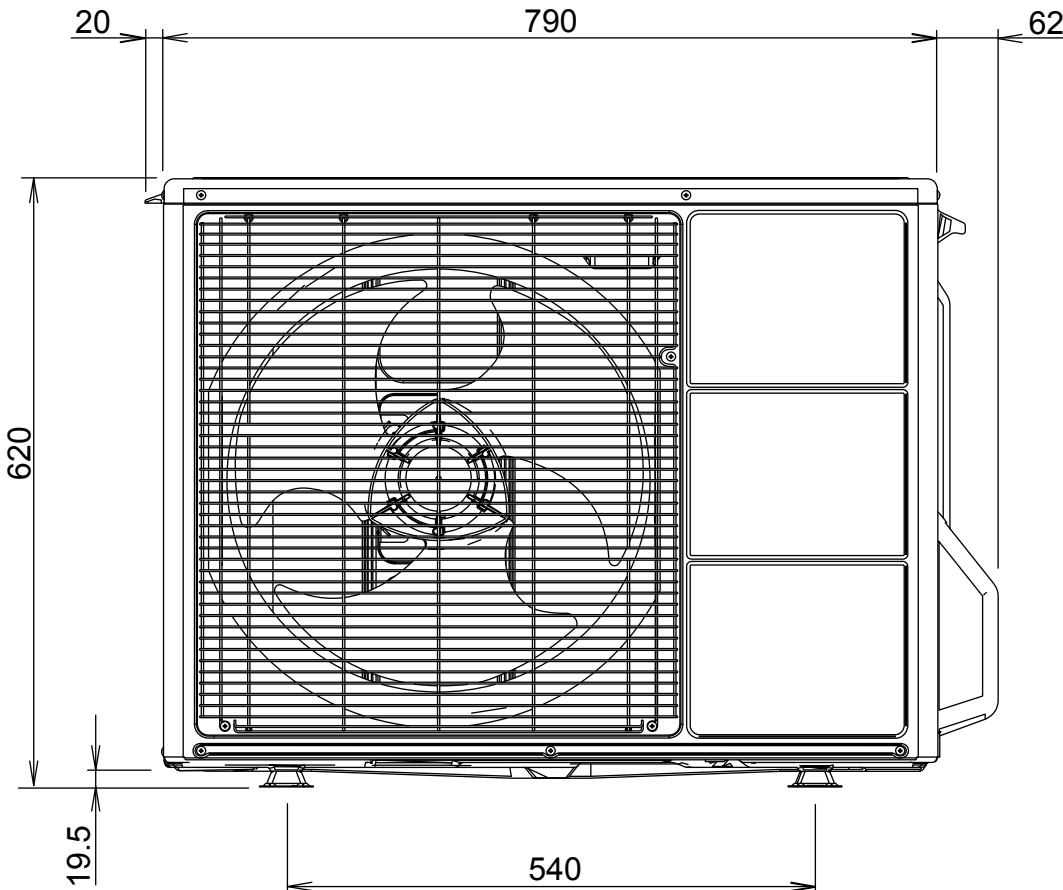

REFRIGERANT SYSTEM DIAGRAM

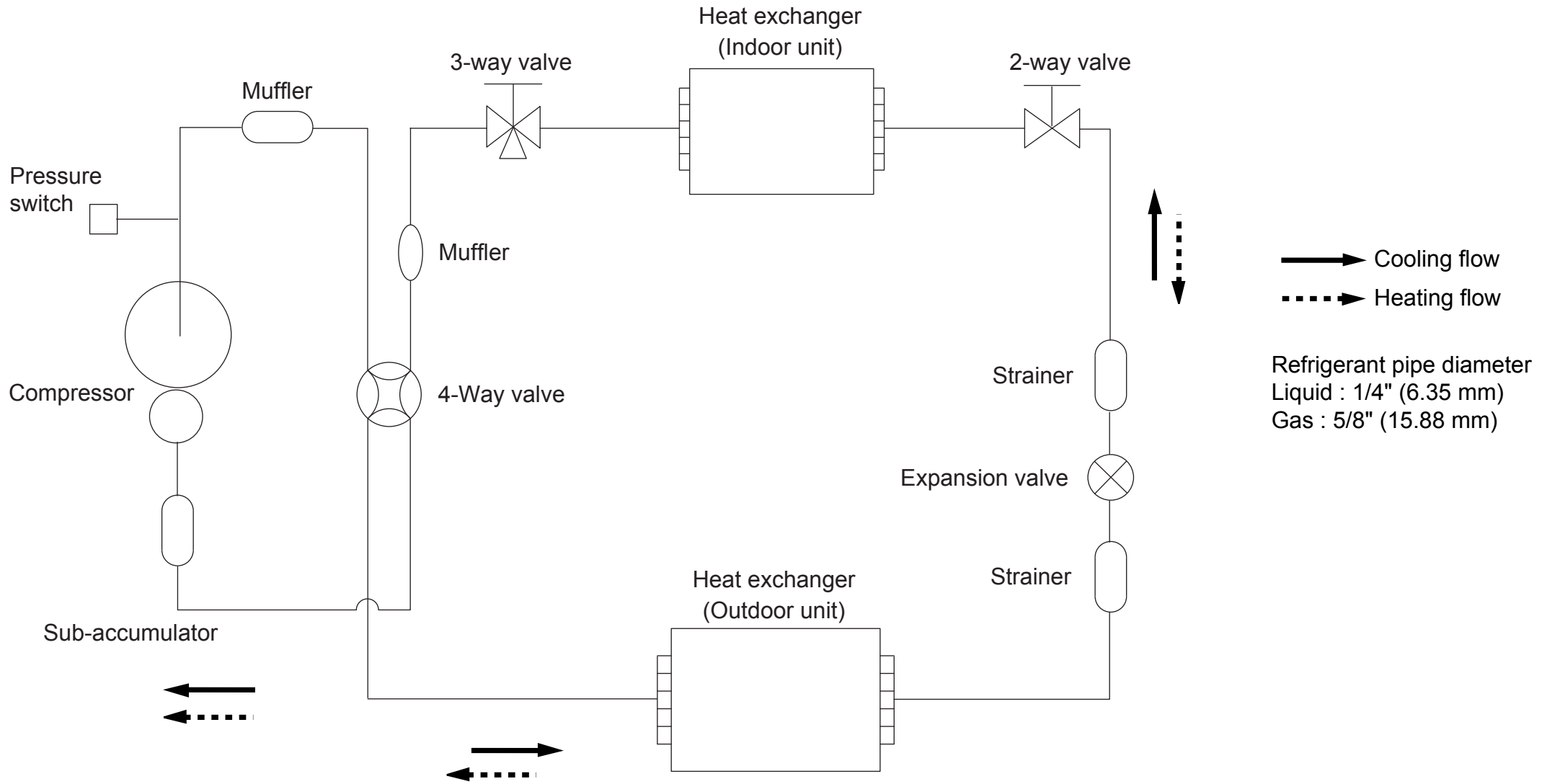

CIRCUIT DIAGRAM

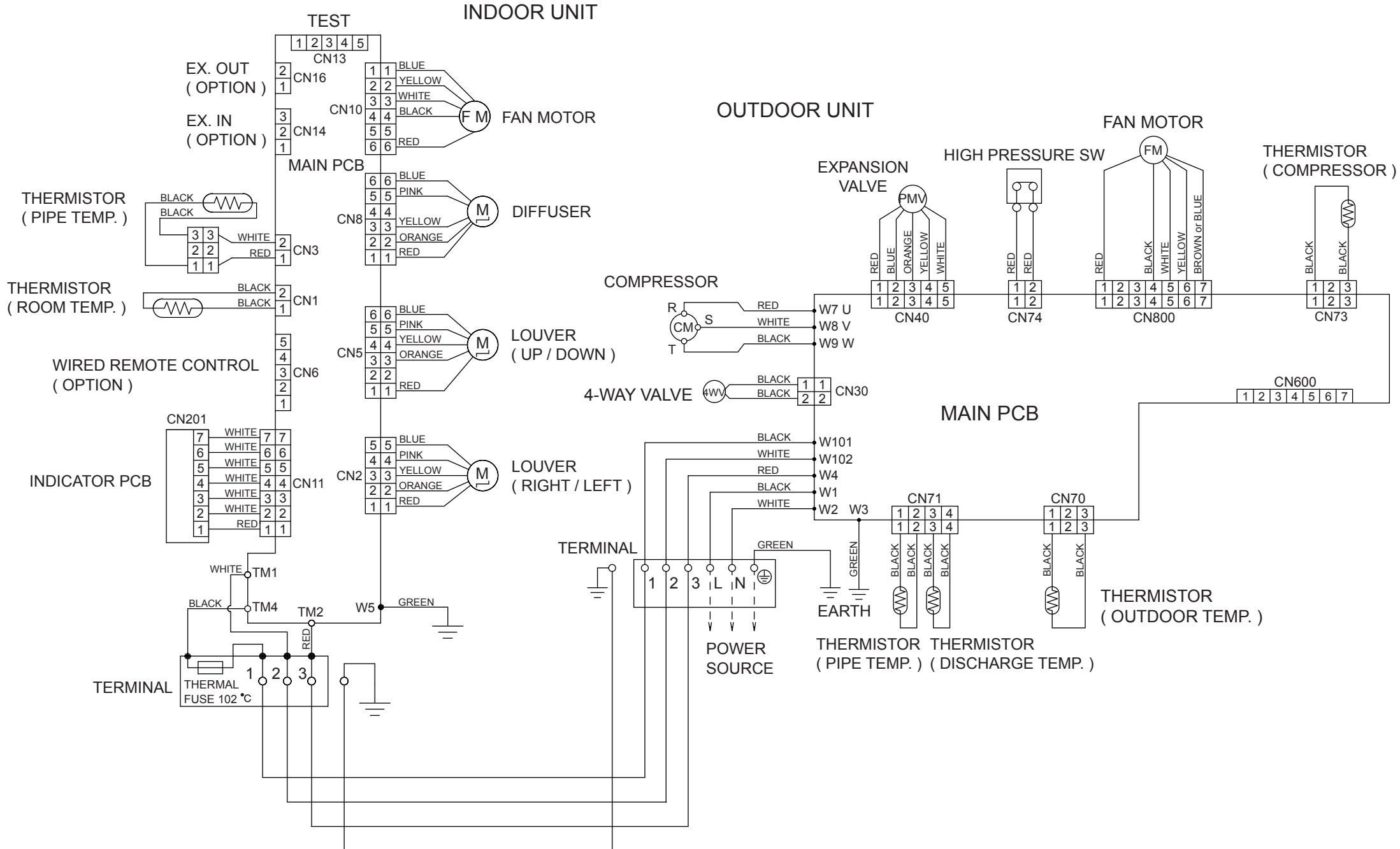

INDOOR PCB CIRCUIT DIAGRAM

CONTROL UNIT
EZ-01211HSE

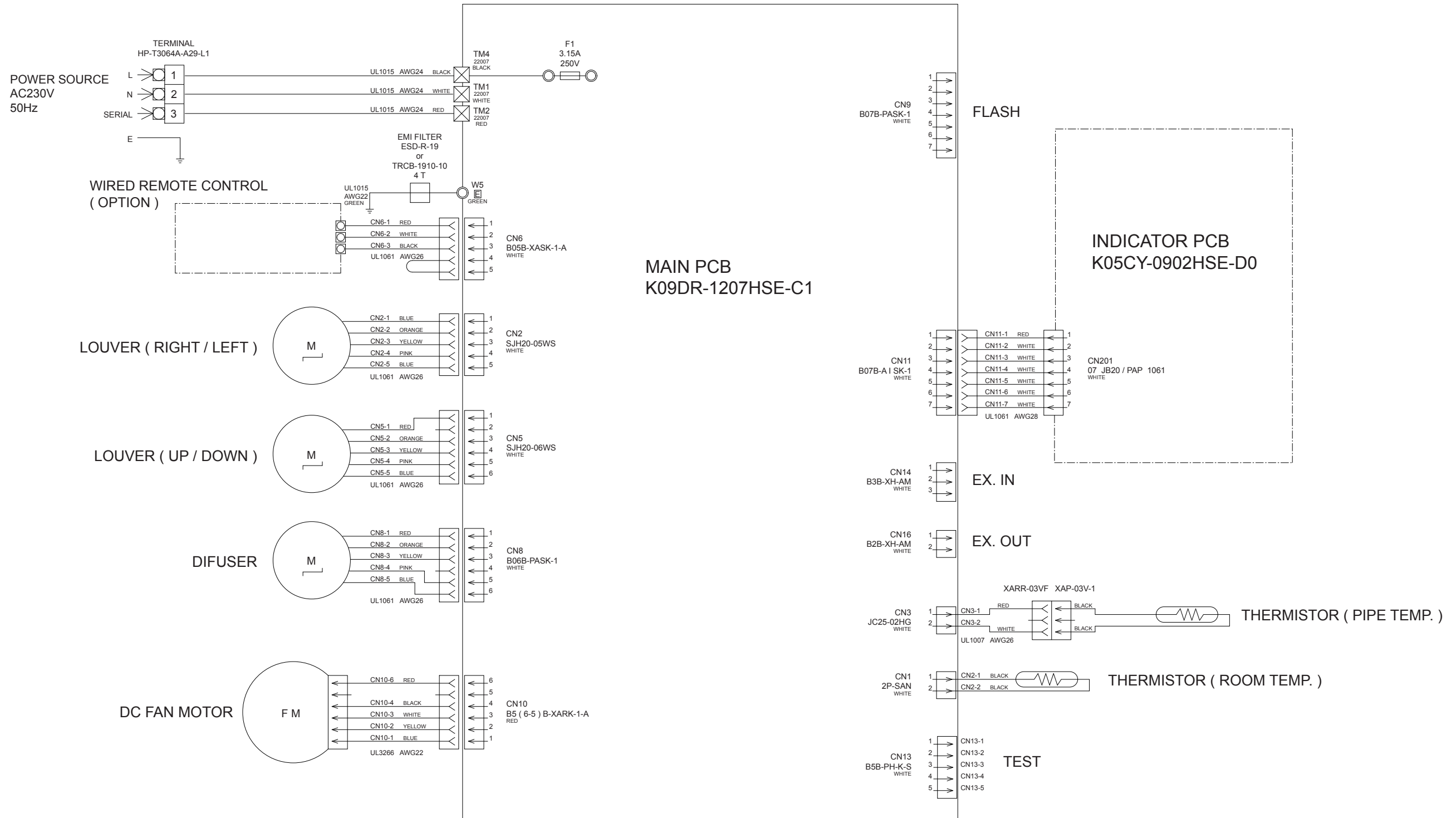

INDOOR UNIT
MAIN PCB
K09DR-1207HSE-C1

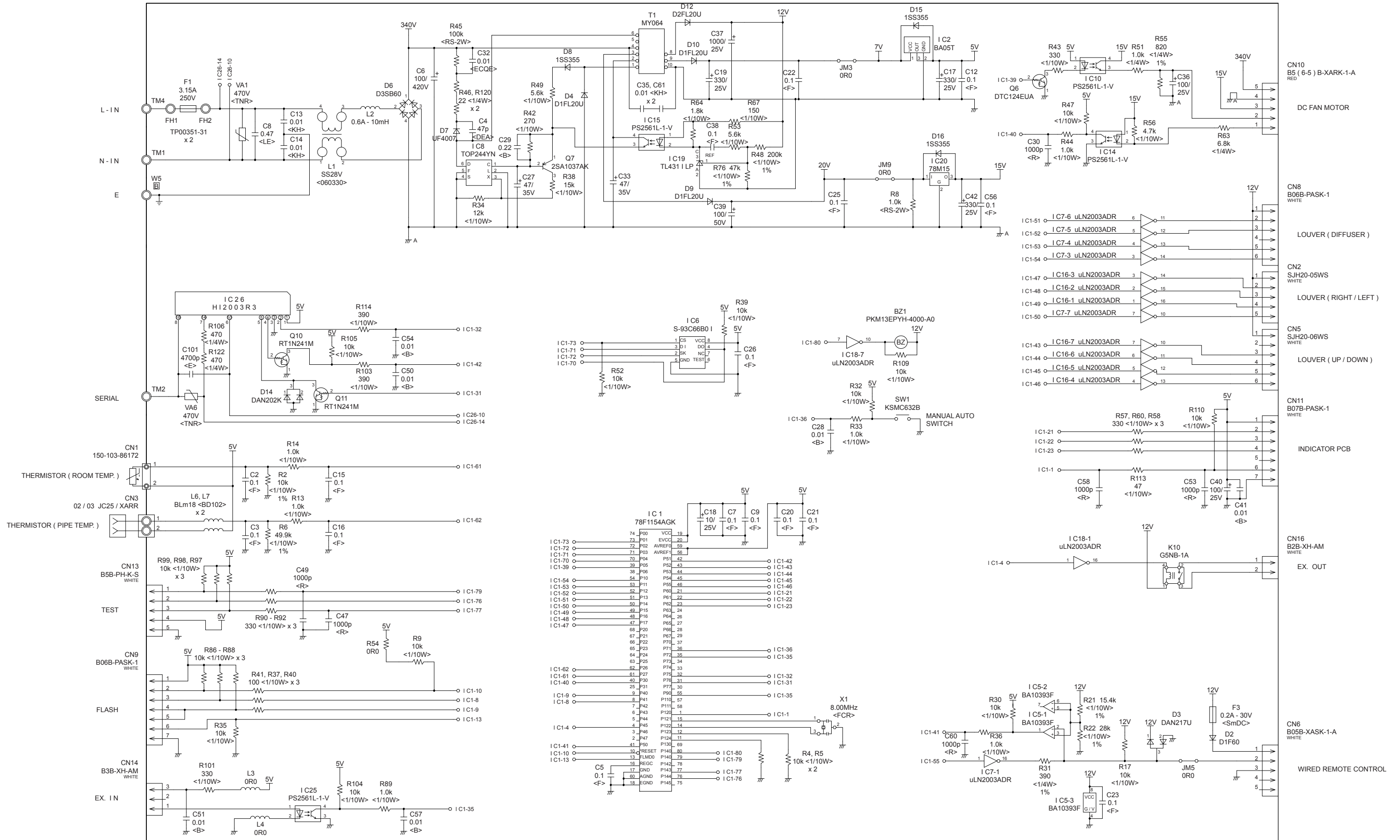

INDOOR UNIT
 INDICATOR PCB
 K05CY-0902HSE-D0

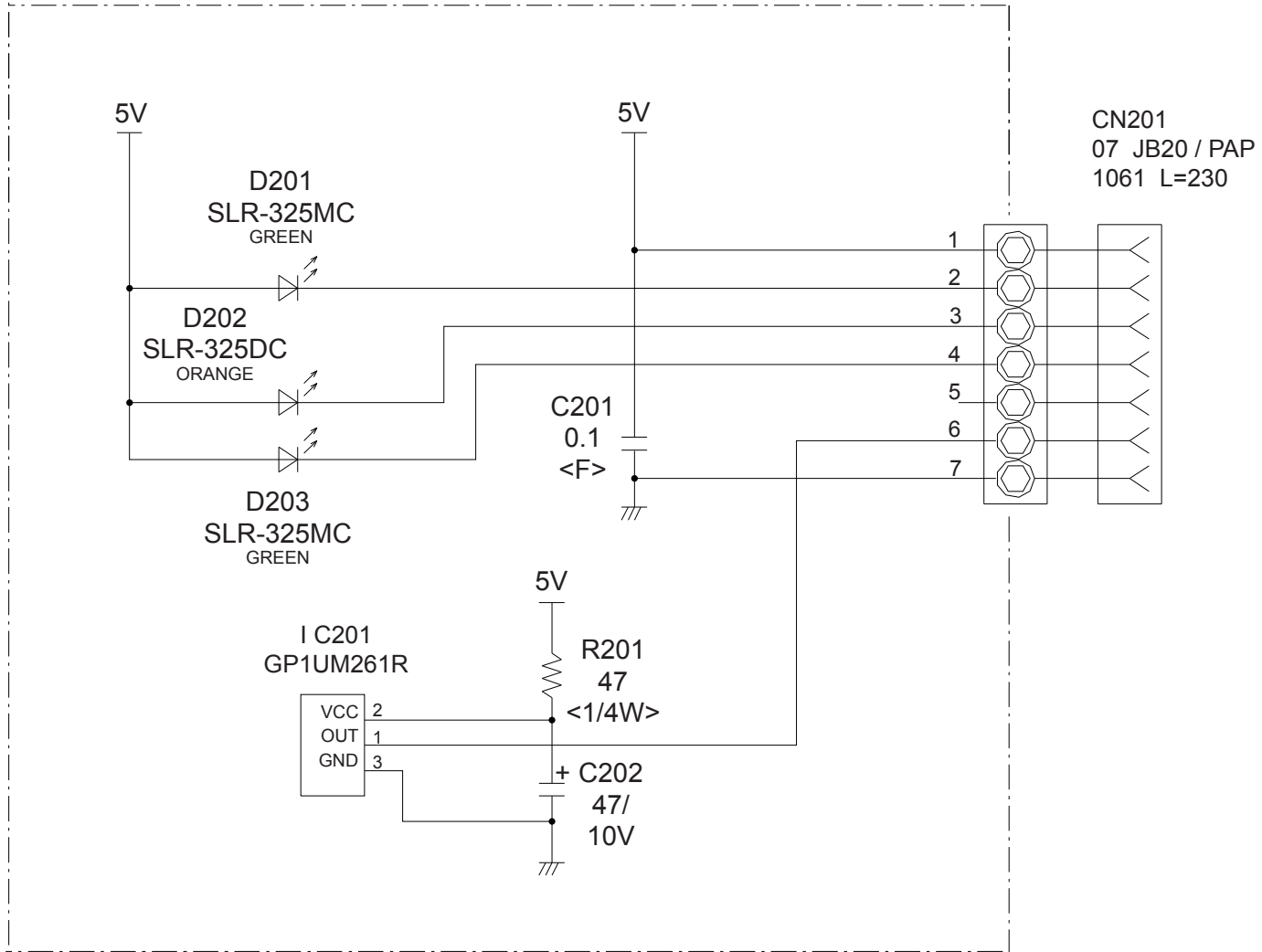

OUTDOOR PCB CIRCUIT DIAGRAM

INVERTER ASSEMBLY EZ-012YHUE

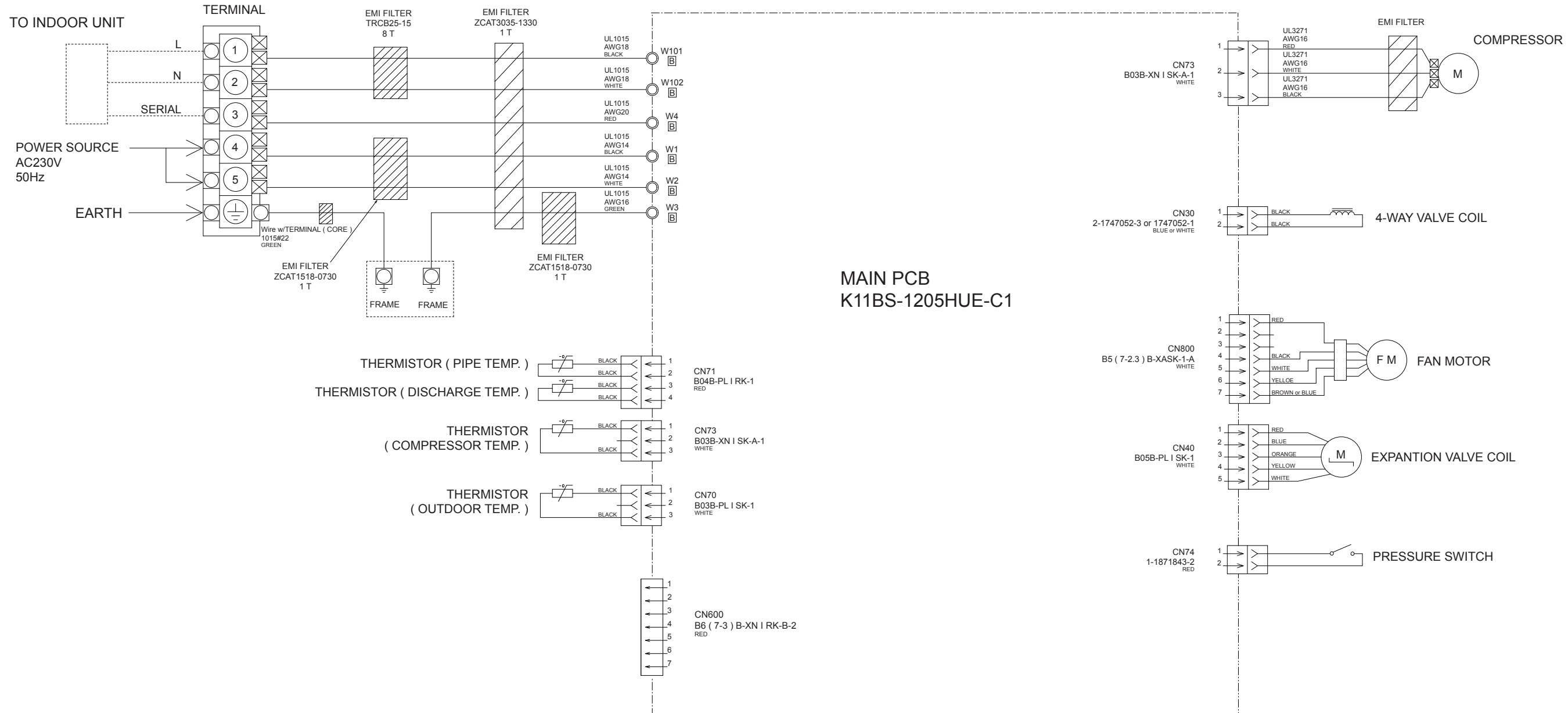

OUTDOOR UNIT
MAIN PCB
K11BS-1205HUE-C1

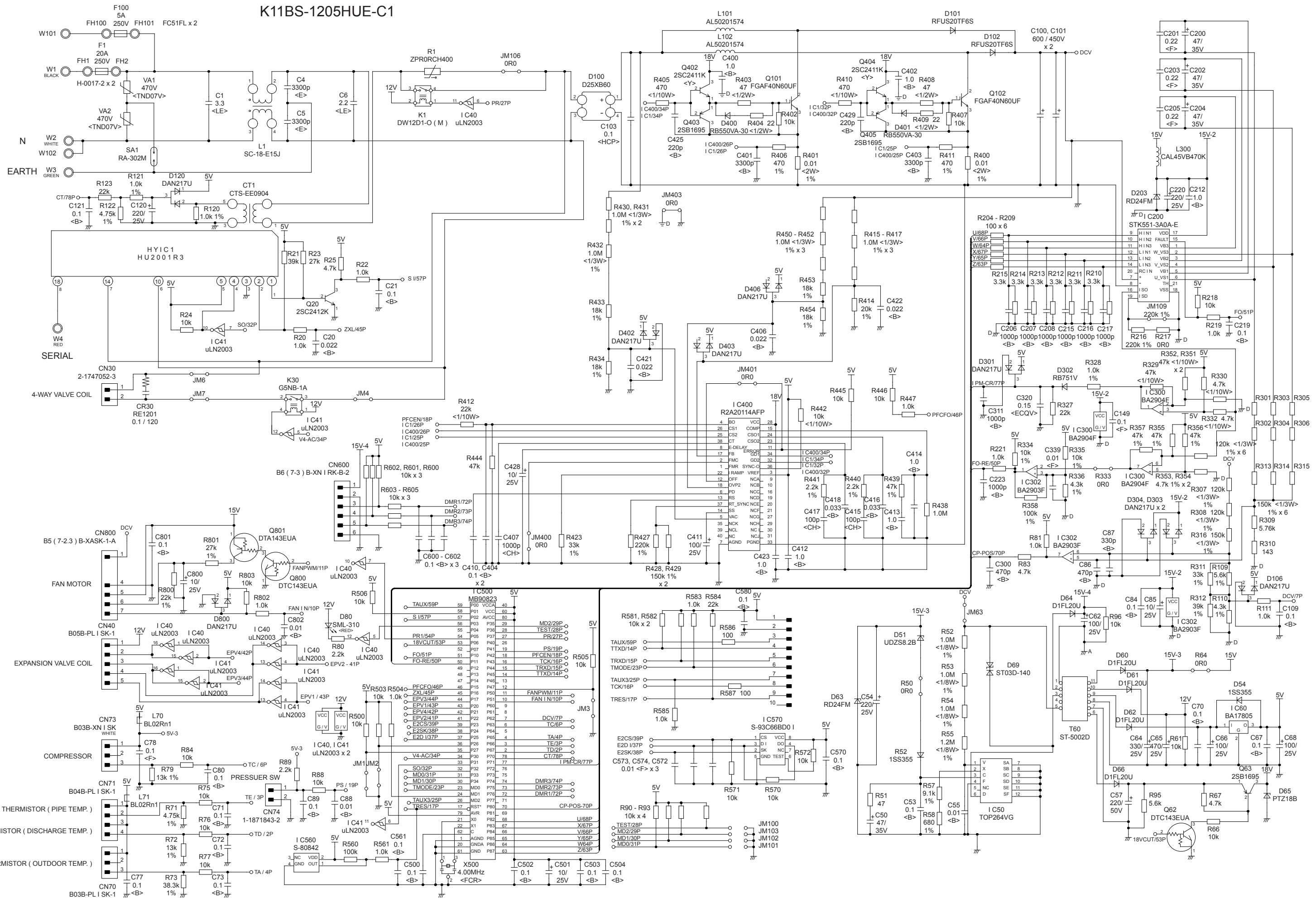

ERROR DETECTION

INDOOR UNIT and WIRED REMOTE CONTROL

If you use a wireless remote control, the lamp on the photo detector unit will output error codes by way of blinking patterns.

If you use a wired remote control, error codes will appear on the remote control display. See the lamp blinking patterns and error codes in the table. An error display is displayed only during operation.

Troubleshooting with the wired remote control.

If an error occurs, the following display will be shown. ("Er" will appear in the set room temperature display.)

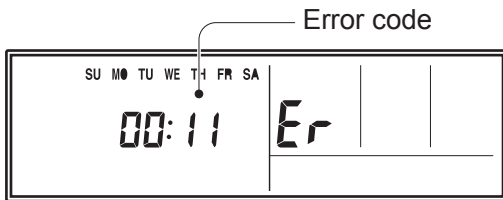

EX. Self-diagnosis

● : 0.5s on / 0.5s off

◇ : 0.1s on / 0.1s off

() : Number of flashing

Indoor unit lamps			Wired remote control	Description
OPERATION (green)	TIMER (orange)	ECONOMY (green)		
●(1)	●(1)	◇	11	Serial communication error
●(1)	●(2)	◇	12	Wired remote control communication error
●(1)	●(5)	◇	15	Check run unfinished
●(2)	●(1)	◇	21	Unit number or Refrigerant circuit address setting error [Simultaneous Multi]
●(2)	●(2)	◇	22	Indoor unit capacity error
●(2)	●(3)	◇	23	Combination error
●(2)	●(4)	◇	24	• Connection unit number error (indoor slave unit) [Simultaneous Multi] • Connection unit number error (indoor unit or branch unit) [Flexible Multi]
●(2)	●(7)	◇	27	Primary unit, secondary unit set-up error [Simultaneous Multi]
●(3)	●(2)	◇	32	Indoor unit PCB model information error
●(3)	●(5)	◇	35	Manual auto switch error
●(4)	●(1)	◇	41	Inlet air temp. sensor error
●(4)	●(2)	◇	42	Indoor unit Heat Ex. Middle temp. sensor error
●(5)	●(1)	◇	51	Indoor unit fan motor error
●(5)	●(3)	◇	53	Drain pump error
●(5)	●(7)	◇	57	Damper error
●(5)	●(15)	◇	5U	Indoor unit error
●(6)	●(2)	◇	62	Outdoor unit main PCB model information error or communication error
●(6)	●(3)	◇	63	Inverter error
●(6)	●(4)	◇	64	Active filter error, PFC circuit error
●(6)	●(5)	◇	65	Trip terminal L error

Indoor unit lamps			Wired remote control	Description
OPERATION (green)	TIMER (orange)	ECONOMY (green)		
●(6)	●(10)	◇	6A	Display PCB microcomputers communication error
●(7)	●(1)	◇	71	Discharge temp. sensor error
●(7)	●(2)	◇	72	Compressor temp. sensor error
●(7)	●(3)	◇	73	Outdoor unit Heat Ex. liquid temp. sensor error
●(7)	●(4)	◇	74	Outdoor temp. sensor error
●(7)	●(5)	◇	75	Suction Gas temp. sensor error
●(7)	●(6)	◇	76	• 2-way valve temp. sensor error • 3-way valve temp. sensor error
●(7)	●(7)	◇	77	Heat sink temp. sensor error
●(8)	●(2)	◇	82	• Sub-cool Heat Ex. gas inlet temp. sensor error • Sub-cool Heat Ex. gas outlet temp. sensor error
●(8)	●(3)	◇	83	Liquid pipe temp. sensor error
●(8)	●(4)	◇	84	Current sensor error
●(8)	●(6)	◇	86	• Discharge pressure sensor error • Suction pressure sensor error • High pressure switch error
●(9)	●(4)	◇	94	Trip detection
●(9)	●(5)	◇	95	Compressor rotor position detection error (permanent stop)
●(9)	●(7)	◇	97	Outdoor unit fan motor error
●(9)	●(9)	◇	99	4-way valve error
●(10)	●(1)	◇	A1	Discharge temp. error
●(10)	●(3)	◇	A3	Compressor temp. error
●(10)	●(4)	◇	A4	High pressure error
●(10)	●(5)	◇	A5	Low pressure error
●(13)	●(2)	◇	J2	Branch boxes error [Flexible Multi]

PARTS

INDOOR UNIT

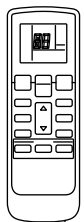
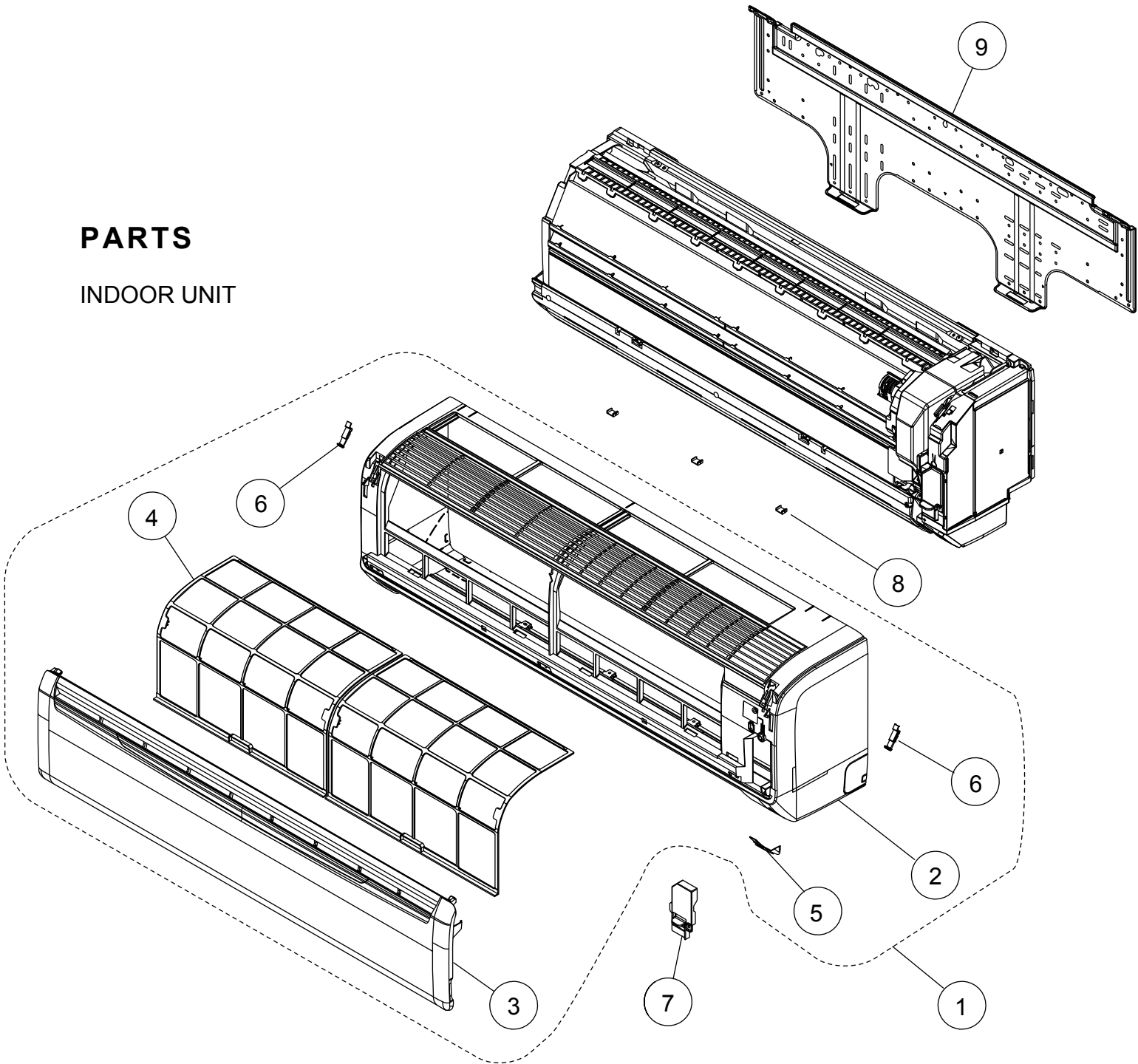

10

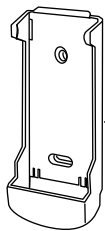

11

Ref	Description	Parts number
1	Front Panel Total Assy	9318738001
2	Front Panel	9314991080
3	Intake Grille Assy	9385985049
4	Air Filter	9315014016
5	Receiver Window	9315010018
6	Clamber Grille	9306755010
7	Wire Clamber	9315015013
8	Cap (Screw)	9309002074
9	Bracket Panel	9315023018
10	Remote Control	9379219037
11	Remote Control Holder	9305642045
--	Air Clean Filter Assy	9315212016

INDOOR UNIT

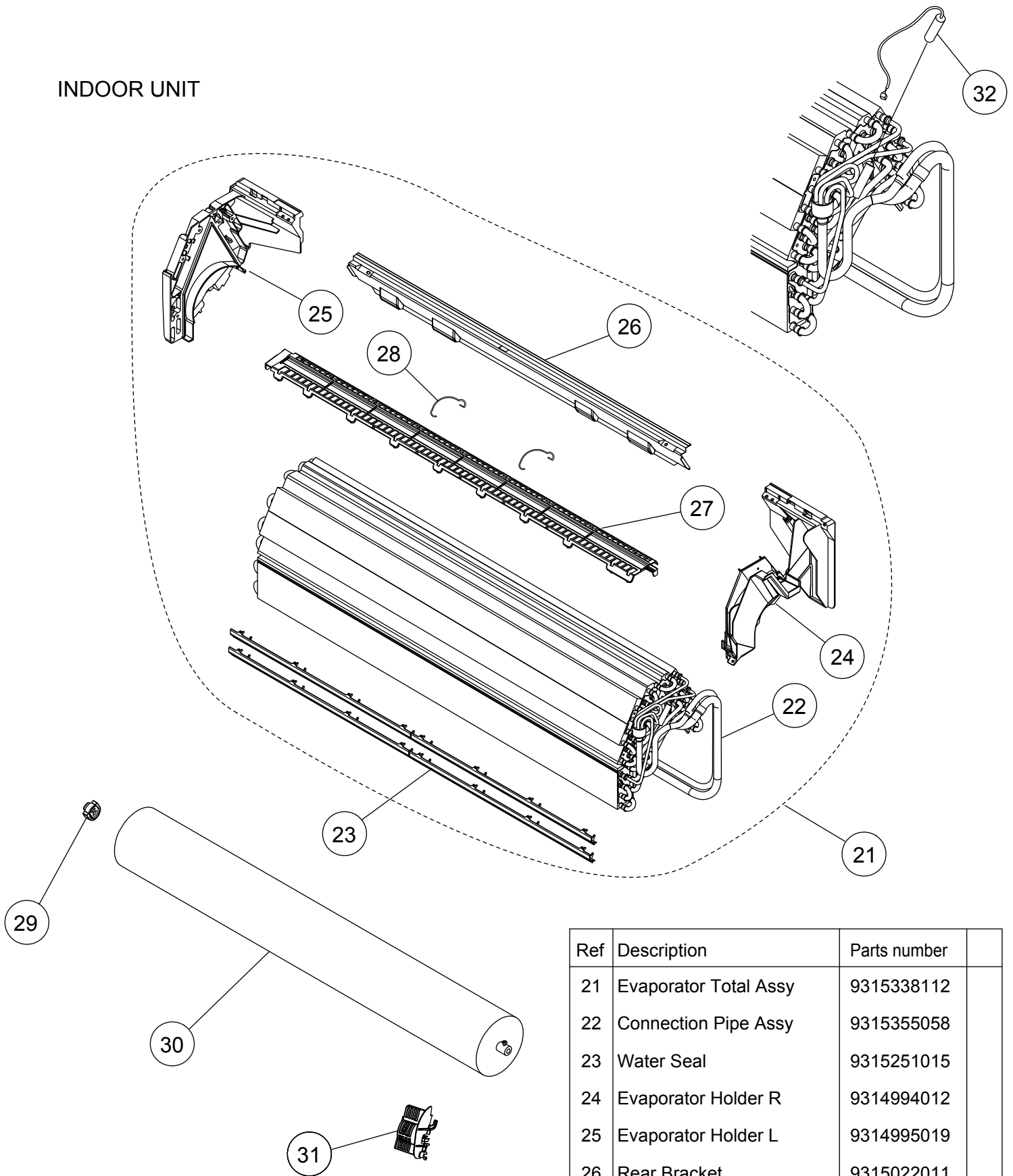

Ref	Description	Parts number
21	Evaporator Total Assy	9315338112
22	Connection Pipe Assy	9315355058
23	Water Seal	9315251015
24	Evaporator Holder R	9314994012
25	Evaporator Holder L	9314995019
26	Rear Bracket	9315022011
27	Filter Guide	9315013019
28	Filter Guard	9315411013
29	Bearing C Assy	9306628017
30	Crossflow Fan Assy	9315024015
31	Holder (Room Thermistor)	9315252012
32	Pipe Thermistor	9900551018

INDOOR UNIT

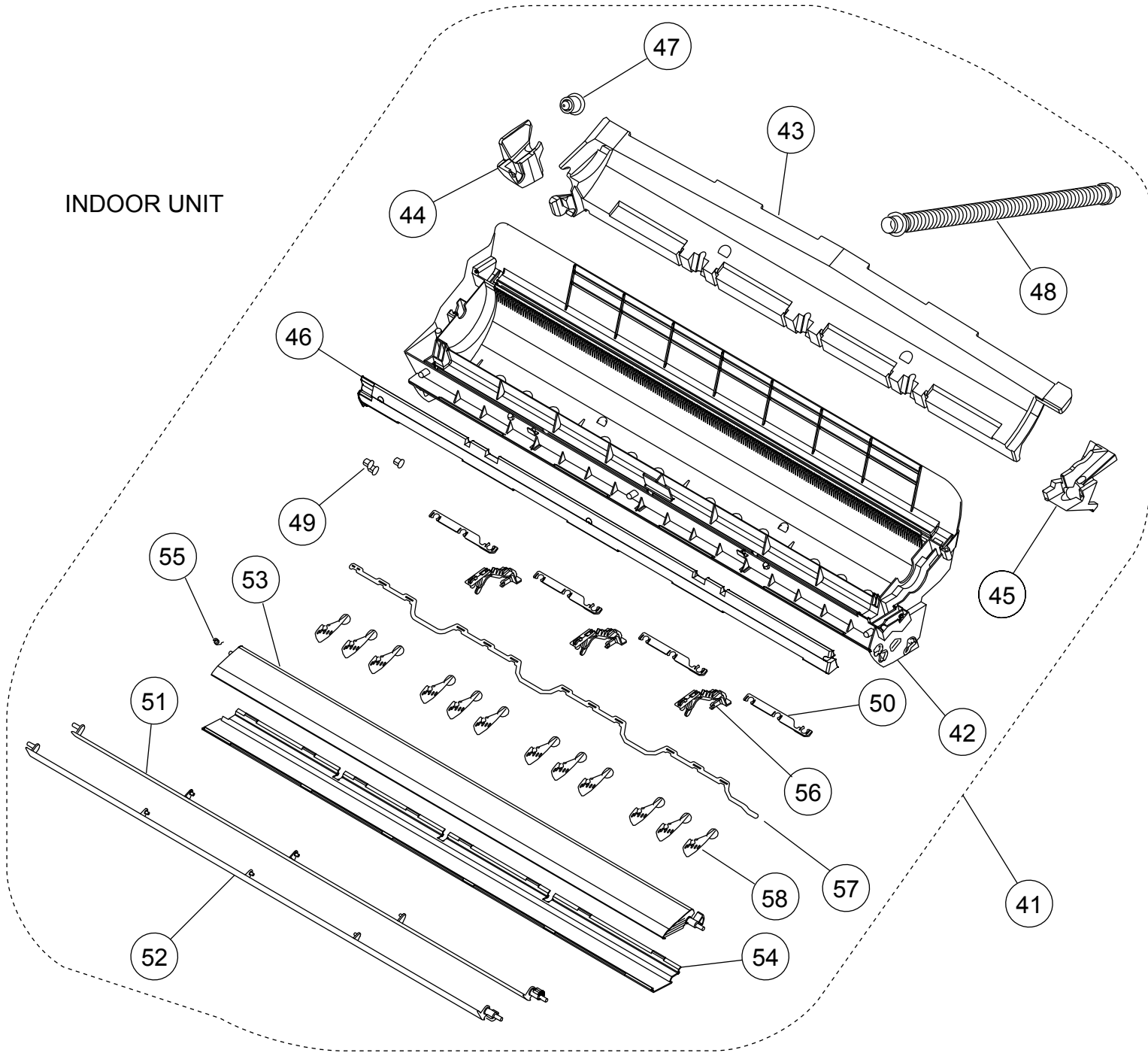

Ref	Description	Parts number
41	Casing Assy	9315331045
42	Casing	9314993015
43	Casing Cover B	9315016010
44	Casing Cover L	9315017017
45	Casing Cover R	9315018014
46	Casing Cover F	9315019011
47	Drain Cap	9367677009
48	Drain Hose Assy	9315769015
49	Bush B	9312156016
50	Spacer D	9315282019

Ref	Description	Parts number
51	Louver U	9315000026
52	Louver Z	9315001023
53	Diffuser U	9315002020
54	Diffuser Z	9315003027
55	Spring C	9314142017
56	Pillar A	9315009012
57	Joint B	9315006011
58	R and L Louver	9311997016
-	Fan Guard	9305751051
-	Fan Guard Holder Right	9315814012
-	Fan Guard Holder Left	9315815019

INDOOR UNIT

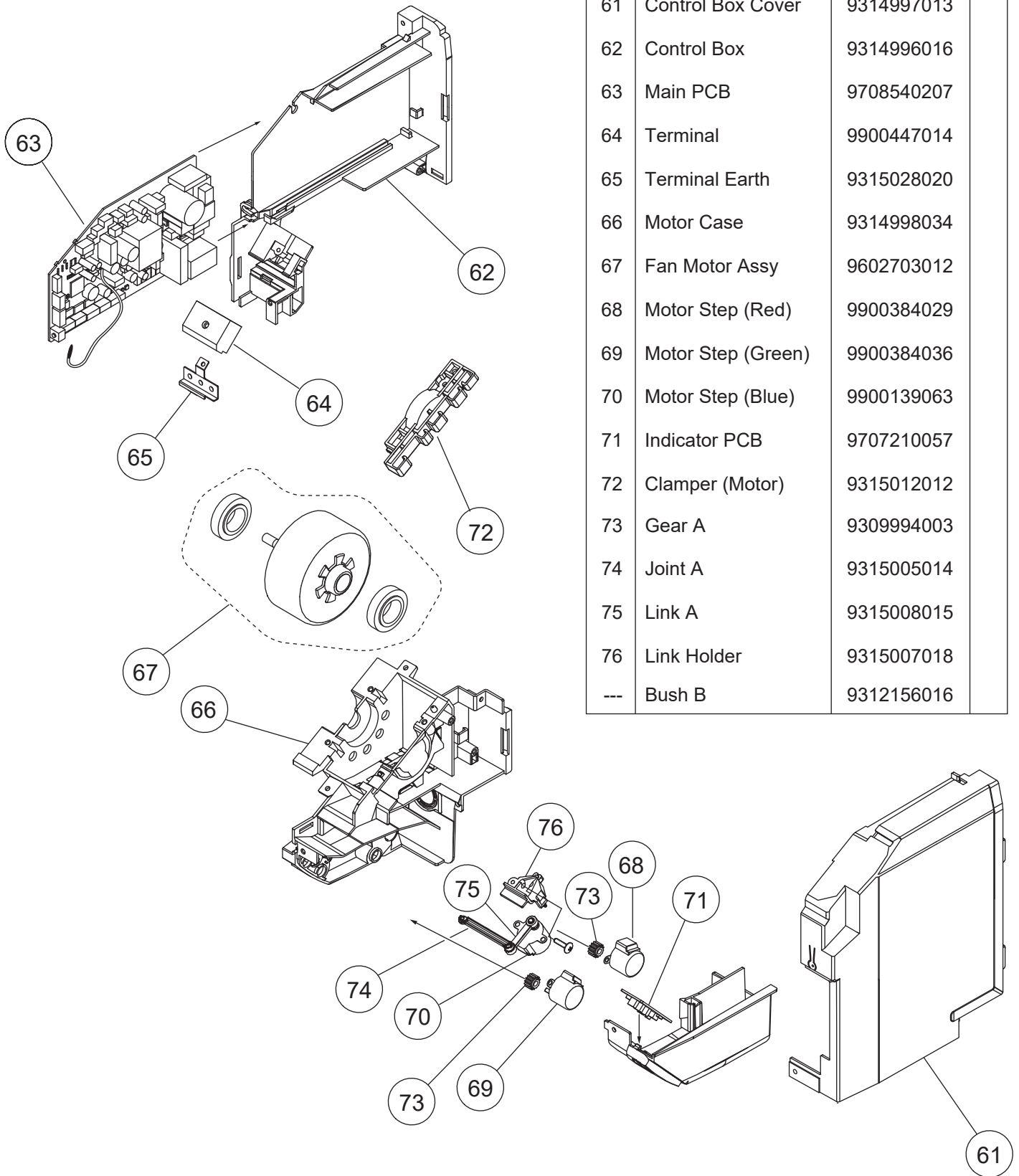

PARTS

OUTDOOR UNIT

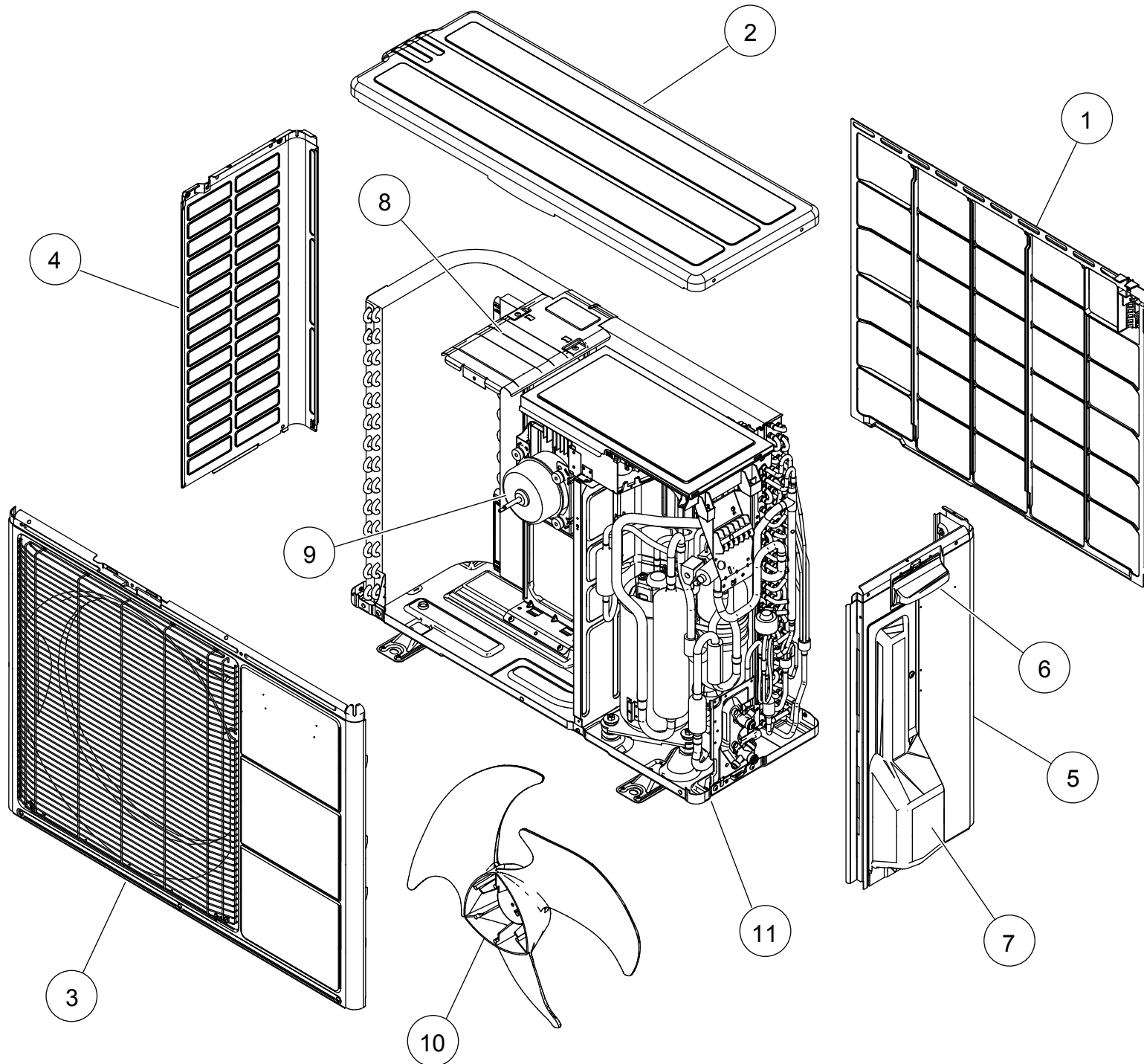

Ref.	Description	Part number
1	Protective Net	9331640015
2	Top Panel Assy	9318464139
3	Front Panel Assy	9318463040
4	Cabinet Left Assy	9318461015
5	Cabinet Right Assy	9318462012
6	Grip	9317588003
7	Switch Cover Assy	9318499001
8	Motor Bracket Assy	9319124001
9	Fan Motor	9602724017
10	Propeller Fan	9313808013
11	Base Assy	9316885066
--	Emblem	9319151007
--	Drain Assy	9303029022

OUTDOOR UNIT

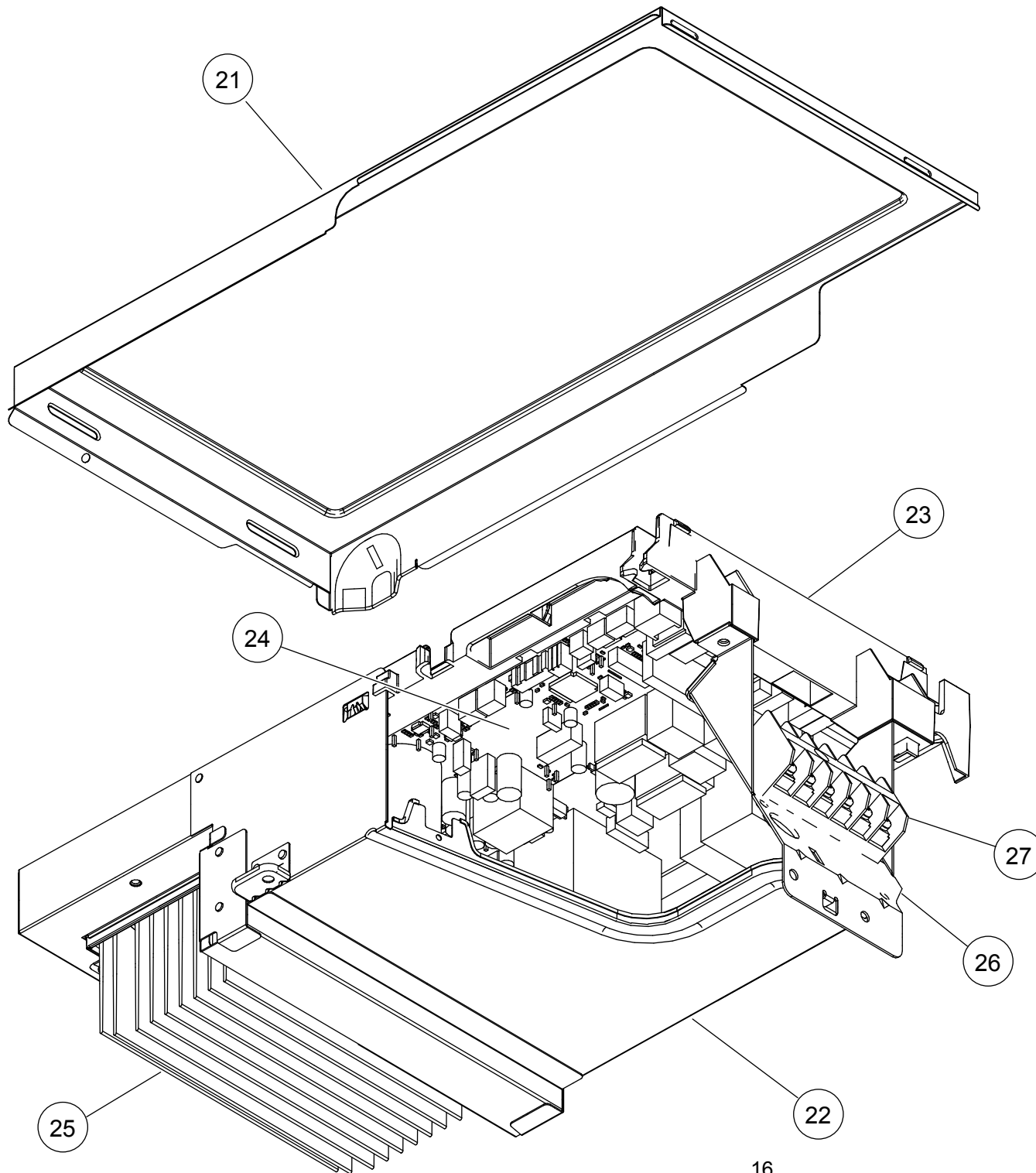

Ref.	Description	Part number
21	Shield Panel	9319542003
22	Inverter Case Assy	9319548012
23	PCB Holder	9319547015
24	Main PCB	9708996165
25	Heat Sink	9319540009
26	Terminal Bracket	9319543017
27	Terminal 6P	9900435028
--	Outdoor Thermistor	9900565008
--	Thermistor Assy	9900727017
--	Compressor Thermistor	9900777012

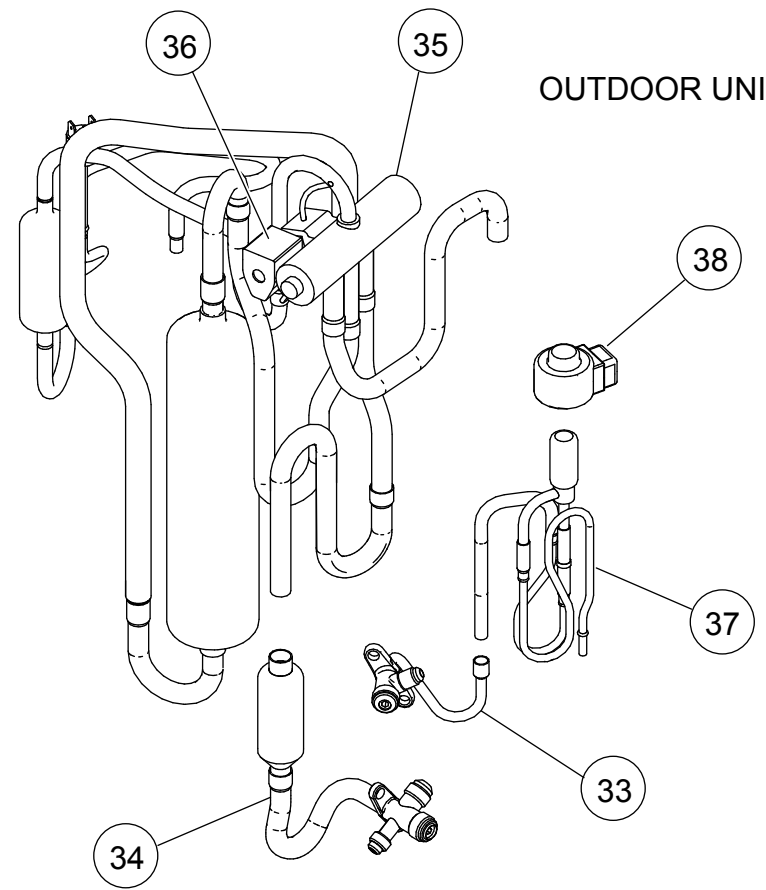
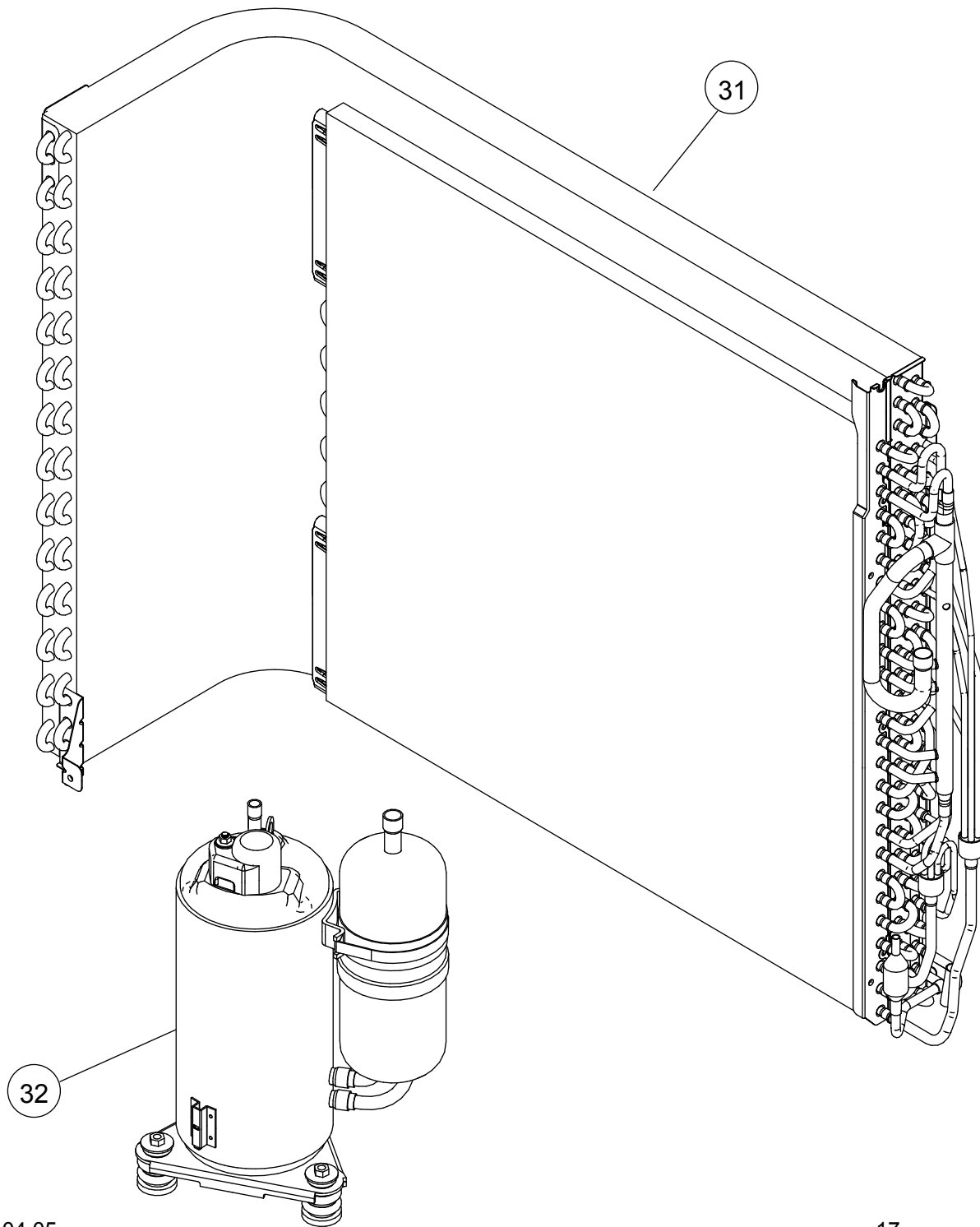



OUTDOOR UNIT

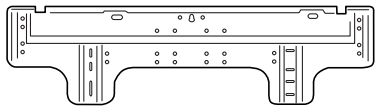
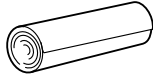
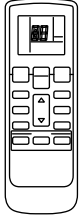
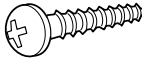
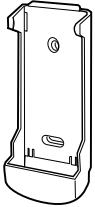

Ref.	Description	Part number
31	Condenser Total Assy	9317089166
32	Compressor	9810244000
33	2-way Valve Assy	9314554018
34	3-way Valve Sub Assy	9319098005
35	4-way Valve Assy	9319874012
36	Solenoid	9970110023
37	Pulse Motor Valve Assy	9314557019
38	Expansion Valve Coil	9970095030

ACCESSORIES

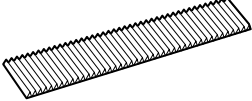
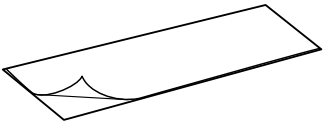
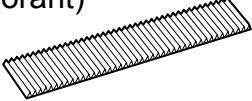
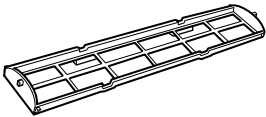
INDOOR UNIT

Name and Shape	Part number	Name and Shape	Part number
Wall hook bracket 	9315023018	Cloth tape 	9310519004
Remote control 	9379219037	Tapping screw (big) 	0700076046
Remote control holder 	9305642045	Tapping screw (small) 	0700019036
Battery (penlight) 	0600185541	Air cleaning filter (Apple katekin) 	UTR-FA13-1
Drain hose insulation 	9361756007	Air cleaning filter (Ion deodorant) 	UTR-FA13-2
		Filter holder 	9368568009

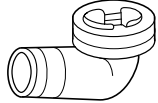
OUTDOOR UNIT

Name and Shape	Part number
Drain assy 	9303029022
Drain cap 	313166024302

1211G4132