

Small VRF system

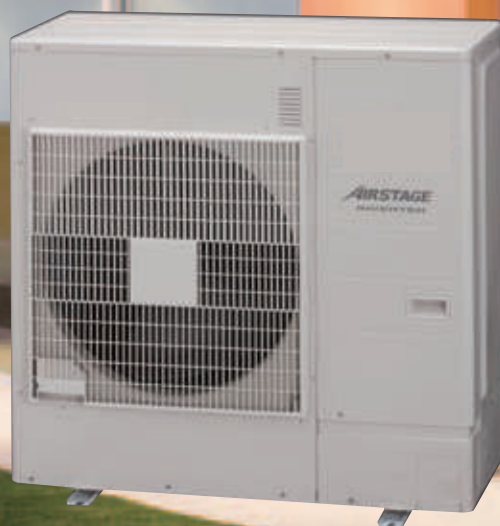

AIRSTAGE™ J-IIS

SERVICE MANUAL



FUJITSU GENERAL LIMITED

CONTENTS

1. TEST RUN

1-1 EXECUTION PROCEDURE AND EXECUTION PRECAUTIONS	01-01
1-2 TEST RUN METHOD	01-03
1-2-1 Check Items Before Power ON.....	01-03
1-2-2 Check Items After Power ON.....	01-04
1-2-3 Automatic address setting procedure for Signal amplifiers.....	01-06
1-2-4 Automatic address setting procedure for indoor units.....	01-07
1-2-5 Indoor unit connection check.....	01-08
1-2-6 Test run from the outdoor unit Main PCB.....	01-09
1-2-7 Test run from Remote controller	01-10
1-3 TEST RUN CONTROL	01-15
1-4 Field Setting And Monitor Mode List for Outdoor unit	01-16
1-5 Field Setting / Function Setting for Indoor unit	01-19
1-6 Field Setting / Function Setting for Outdoor air unit	01-20

2. OUTDOOR UNIT OPERATION CONTROL

2-1 INPUT / OUTPUT LIST	02-01
2-2 COMPRESSOR OPERATION	02-02
2-2-1 Operation / Stop Condition.....	02-02
2-2-2 Capacity Control.....	02-02
2-2-3 Speed Range of Start,Stop,and Operation.....	02-03
2-3 FAN CONTROL	02-05
2-3-1 Cooling Operation.....	02-05
2-3-2 Heating Operation.....	02-06
2-3-3 Low noise mode.....	02-07
2-3-4 Other Control.....	02-07
2-4 EXPANSION VALVE CONTROL	02-07
2-5 SPECIAL OPERATION	02-08
2-5-1 Oil Recovery Operation.....	02-08
2-5-2 Pre-Heat Operation.....	02-09
2-5-3 Defrost Operation Control.....	02-09
2-6 PROTECTIVE FUNCTION	02-10
2-6-1 Protective Function List.....	02-10

CONTENTS

3. INDOOR UNIT OPERATION

3-1 FAN CONTROL	03-01
3-1-1 Fan Speed Setting.....	03-01
3-1-2 "AUTO" Position.....	03-01
3-2 MASTER CONTROL	03-02
3-2-1 Operation Mode Control.....	03-02
3-2-2 Auto Changeover.....	03-04
3-2-3 "COOL" Position.....	03-05
3-2-4 "HEAT" Position.....	03-05
3-3 LOUVER CONTROL	03-06
3-4 ELECTRONIC EXPANSION VALVE CONTROL	03-09
3-5 DRAIN PUMP OPERATION	03-09
3-6 FUNCTION	03-10
3-6-1 Auto Restart.....	03-10
3-6-2 Icing Protection Control.....	03-10
3-6-3 Oil Recovery Operation.....	03-10
3-6-4 Outdoor temperature protected operation for Outdoor air unit.....	03-11
3-7 DX-KIT	03-12
3-7-1 System configuration	03-12
3-7-2,3 Fundamental functions	03-13
3-7-4 Electrical expansion valve control for DX-KIT.....	03-15
3-7-5 Drain pump operation for DX-KIT	03-14
3-7-6 Function	03-16

4. TROUBLE SHOOTING

4-1 NORMAL OPERATION	04-01
4-1-1 Indoor Unit Display.....	04-01
4-1-2 Outdoor Unit Display.....	04-02
4-2 ABNORMAL OPERATION	04-03
4-2-1 Indoor Unit Display.....	04-03
4-2-2 Outdoor Unit Display.....	04-04
4-2-3 Error Code List for Outdoor Unit.....	04-05
4-2-4 Remote Controller Display.....	04-06
4-2-5 Error Code List for Simple and Wired Remote Controller.....	04-07
4-2-6 Trouble Level of System.....	04-08
4-2-7 Error History Mode.....	04-10
4-3 TROUBLE SHOOTING	04-11
4-3-1 Trouble Shooting With Error Code (INDOOR UNIT).....	04-11
4-3-2 Trouble Shooting With Error Code (OUTDOOR UNIT).....	04-26
4-3-3 Trouble Shooting With No Error Code.....	04-56
4-3-4 Trouble Shooting for Optional Parts.....	04-61
4-4 SERVICE PARTS INFORMATION	04-82

CONTENTS

5. APPENDING DATA

5-1 REFRIGERANT CIRCUIT	05-01
5-2 WIRING DIAGRAM	05-02
5-2-1 Indoor Unit.....	05-02
5-2-2 Outdoor Unit.....	05-14
5-2-3 Outdoor Air Unit.....	05-14 ⁺¹
5-2-4 DX-Kit	05-14 ⁺³
5-3 CHARACTERISTICS OF SENSORS	05-15
5-3-1 Pressure sensor.....	05-15
5-3-2 Thermistor resistance.....	05-16
5-3-3 Saturation temperature and saturation pressure tables (R410A).....	05-17
5-3-4 Temperature and pressure of refrigerant (Graph).....	05-18

6. DISASSEMBLY PROCESS



AIRSTAGE™ J-IIS

Variable Refrigerant Flow System

1. TEST RUN

1. TEST RUN

1-1 EXECUTION PROCEDURE AND EXECUTION PRECAUTIONS

Before execution

Execution procedure and precautions	Reason
Do not install the units in the place not recommended in the installation manual.	• The performance may drop significantly due to the protection controlling
Check the characteristics of the refrigerant used and grasp the special features of the refrigerant. If refrigerant must be charged, always charge the refrigerant specified for the product. *Confirm the product design pressure. < R410A 4.12MPa >	• Use of a refrigerant other than the specified refrigerant will invite equipment trouble
Prepare the design for the system	
① Use new refrigerant piping of the thickness specified by the D&T manual. ② Since R410A dedicated tools are necessary, prepare them in advance. ③ Absolutely avoid use of existing piping. If use of existing piping is unavoidable, the piping must be cleaned.	• Secure the necessary pressure resistance.

Execution 1/2

Sleeve and insert work	Always use a level and keep the indoor unit level. If the equipment is tilted toward the drain port, install it so that the tilt is within 10mm. Excessive tilt will cause water leakage.	• Prevention of water leakage
Indoor unit installation	When performing piping work, observe the following items so that the inside of the piping is clean and air tight. ① Use pipe that is not dirty inside. ② Confirm the design for the piping (Diameter, Thickness) ③ When the pipe is left standing, protect it. ④ Confirm the angle of separation tube and header correctly. ⑤ Finish flaring exactly. ⑥ Confirm the width across flats dimension and shape of flare nuts. ⑦ Always blow nitrogen while brazing. ⑧ Perform flushing before connecting the equipment.	• Foreign matter, water, etc. in the piping will cause faulty cooling and compressor trouble. • Incorrect pipe diameter will cause faulty cooling • Incorrect angle of separation tube or header will be cause poor cooling or refrigerant noise problem • Refrigerant leakage will cause low performance and abnormal stopping
Refrigerant piping work		
Drain piping work	① Always make the downward slope of the drain pipe 1/100 or greater and make the horizontal length within 20m. ② Use hard polyvinylchloride pipe as the drain pipe. ③ Support the drain pipe between 1.5 to 2.0m. ④ Use pipe of 1 rank up (VP30 or greater) as central piping.	• Prevention of water leakage
Duct work		
Heat insulation work	Select the size of the heat insulating material according to the ambient temperature and relative humidity of the refrigerant. Use a heat insulating material having a heat conductivity of 0.043W/(m·k) or less.	• Prevention of water leakage
Electrical work		
Outdoor unit foundation work		
Outdoor unit installation	When making flare connections always use a torque wrench and tighten the flare nut positively to the specified torque.	• Refrigerant leakage will cause low performance and abnormal stopping.
Refrigerant piping connection work	Pressurize the product with nitrogen gas up to the design pressure and conduct a 24Hr air tightness test.	• Refrigerant leakage will cause low performance and abnormal stopping.
Air tightness test	① Install a vacuum pump with reverse flow check mechanism or a reverse flow check adaptor to a conventional vacuum pump and use. ② Pump down sufficiently. Approximately 1 hour or longer after -0.10MPa reached. Allow to stand for approximately 1 hour after stopping the vacuum pump and confirm that the needle does not return. ③ Air purging using refrigerant is strictly prohibited.	• Mixing in of vacuum pump oil by reverse flow will cause equipment trouble. • recommend the vacuuming mode
Vacuum drying		

* Vacuuming mode

This function is used for vacuuming the indoor unit and the connection piping.

Note: For starting Vacuuming mode, the refrigerant address setting has to be finished.(Refer to 01- 06~07)
And the indoor unit connection check has to be finished.(Refer to 01- 08)

When the [vacuuming mode] is set, <Push switch setting, F3:21> EEV of connected all indoor units opens.
So, the vacuuming indoor unit and piping becomes easier.

When the vacuuming ends, please turn off the power supply for all of the indoor units and the outdoor unit, [vacuuming mode] is released.

Execution 2/2

	Execution procedure and precautions	Reason
Addition refrigerant charging	<ol style="list-style-type: none"> ① Confirm the additional refrigerant amount with the installation manual, etc. ② Always take the R410A refrigerant from the cylinder liquid phase and charge it using the gas phase. (Do not lay a cylinder with siphon pipe on its side.) ③ Use an R410A dedicated gauge manifold and charging hose. ④ Charge refrigerant using the liquid pipe. ⑤ When the defined amount of refrigerant cannot charge using the liquid pipe, charge refrigerant using the gas pipe while opening the cooling test run. Charge refrigerant bit by bit with cautious operation of valve for the liquid refrigerant back prevention. 	<ul style="list-style-type: none"> • If taken from the air phase, since the composition of the refrigerant which is charged will change, low performance and abnormal stop will occur easily. • Prevent erroneous sealing in of refrigerant.
Gas leak test	Use an R410A dedicated leak tester to check for gas leaks.	<ul style="list-style-type: none"> • A leak tester for other than R410A cannot detect leaks.
Initial setting	<ol style="list-style-type: none"> ① Set the refrigerant circuit address. ROTARY SW: REF ADX10, X1 ② Confirm the DIP SW setting SET 1: Factory setting, SET 2 : All OFF, SET 3 : All OFF, SET 4: Factory setting ③ Confirm the Terminal resister setting SET 5-4 OFF: Disable, ON: Enable <p>[Note] Perform in the power OFF state.</p>	<ul style="list-style-type: none"> • Dual address setting No. is not allowed in one network. • If the DIP SW setting is wrong, the system may not work correctly • If the Terminal resister setting is wrong, the system may detect transmission error
Address setting for Signal Amp - When using signal Amps -	<p>When setting the address of Signal amplifier, please refer to the installation manual of the signal amplifier. The address setting can be set by automatically from 1 outdoor unit on the network. < Refer to the Page 01-06 Setting mode F3-10 ></p> <p>[Note] Manual setting: Set the rotary SW on the PCB in the power OFF state. Automatic address setting: Perform setting by push button SW on the outdoor unit Main PCB in the power ON state after all indoor units have stopped operation.</p>	<ul style="list-style-type: none"> • Dual address setting No. is not allowed in one network.
Address setting for Indoor unit	<p>Set the refrigerant circuit address and indoor unit address. Can be set by rotary SW on the indoor unit PCB (Main PCB or Switch PCB) or from a remote controller or from a push button SW on the outdoor unit Main PCB < Automatic address setting, Refer to the Page 01-07 Setting mode F3-11></p> <p>[Note] Manual setting: Set the rotary SW on the PCB in the power OFF state. Automatic address setting: Perform setting by push button SW on the outdoor unit Main PCB in the power ON state after all indoor units have stopped operation.</p>	<ul style="list-style-type: none"> • Dual address setting No. is not allowed in one network.
Indoor unit connection check	<p>Before starting the system, check on the number of indoor units and the total capacity. < Refer to the Page 01-08 Setting mode F3-12 ></p> <p>[Note] Perform setting by push button SW on the outdoor unit Main PCB in the power ON state after all indoor units have stopped operation.</p>	<ul style="list-style-type: none"> • Normal operation will not be possible without performing the indoor unit connection check.
Test run & adjustment		
Turnover & explanation of operation		

1-2 TEST RUN METHOD

1-2-1 Check Items Before Power ON

Procedure	Check contents	Judgement standard	Check
Power source	Circuit breaker capacity	Outdoor unit: 32A (AJ*040, 045, 054LCLAH)	
		Indoor unit: 20A	
		Leakage current: 30mA 0.1sec or less	
		Install a breaker (Included with Earth Leakage Circuit Breaker) in accordance with the related laws and regulations.	
	Type of power source wiring	Outdoor unit: 6mm ² 2 wires + Ground 4mm ²	
		Indoor unit: 2.5mm ² 2 wires + Ground	
	Supply power source	Outdoor unit side: AC 230V (220-240V)	
Indoor unit side: AC 230V (220-240V)			
Wiring on terminal blocks	Use crimp-type terminals with insulating sleeves for stranded conductor cable		

Outdoor unit	Appearance	Shall be no scratches, deformation, etc. (Be careful of deformation of the front panel)	
	Serial No.	Shall be checked and entered in the check sheet.	
	Outside air temperature	Shall be checked and entered in the check sheet.	
	Power source wiring connection	Connection points check & loose terminal block screws check	
	Type of communication line	0.33mm ² , shielded wire used (22AWG)	
	Communication line connection	Connection points check & loose terminal panel screws check	
	Connection piping	Check whether or not the heat insulation material is installed without a gap.	
	DIP-SW setting	DIP SW SET1, SET4 : Factory setting, SET2,SET3, SET5-1,2,3: ALL OFF	
		Terminal resistor setting SET5 - 4 OFF: Disable, ON: Enable Check the resistance value for each network segment Refer to the installation manual 7.7	
	Rotary SW setting	Refrigerant circuit address setting (SET : REF AD x10 and REF AD x1)	
	Additional refrigerant amount	Comparison of calculated value and value written on electrics box. Entered in check sheet. Refer to the installation manual 8.3.2	
	3-way valve	Gas pipe: fully open	
Liquid pipe: fully open			

[Note] If operated with the 3-way valve closed, the oil discharged from the compressor will not be returned and will lead to trouble.

Indoor unit	Appearance	There shall be no scratches, deformation, tilting, etc.		
	Serial No.	Shall be checked and entered in the check sheet.		
	Drain cap installation	Shall be installed positively.		
	Power source wiring connection	Connection points check & loose terminal panel screws check		
	Type of communication line	0.33mm ² , shielded wire used (22AWG)		
	Communication line connection	Connection points check & loose terminal panel screws check		
	Type of remote controller wiring	0.33mm ²		
	Remote controller wiring connection	Connection points check & loose terminal panel screws check		
	Connection piping	Check whether or not the heat insulation material is installed without a gap.		
		Rotary SW setting	Refrigerant circuit address (REF AD)	
		Indoor unit address (IU AD)		
		At automatic address setting, IU AD/REF AD shall be [0].		
	DIP-SW setting	Remote controller address (RC AD)		
Function setting (Remote controller custom code/ external input switching/ auxiliary heater ON-OFF)				

1-2-2 Check Items After Power ON

[Note]

Cooling test run for each refrigerant circuit.

If multiple refrigerant circuits are test run at the same time, refrigerant circuit address setting errors cannot be detected.

Procedure	Check contents	Judgement standard	Check
Power ON	Outdoor unit circuit breaker ON	Check lighting of Main PCB LED101 and 7-segment display.	
	Indoor unit circuit breaker ON	Check whether or not indoor unit OPERATION and TIMER lamps flash alternately.	

[Note] Turn on all indoor units power in the same refrigerant circuit address.

When the system operates with the indoor units remaining no power, it is cause of malfunction.

Outdoor unit Main PCB push button SW setting/check	Function setting	Are the necessary functions set ? < For the setting, Refer to the page 01-15~18 >	
--	------------------	--	--

Address setting/ check	Automatic address setting	Addresses shall be assigned to all indoor units / Signal amps. Check for unset or duplicated addresses. < For the setting, Refer to the page 01-06, 07 >	
	Address read	All the indoor units and outdoor units of the same refrigerant circuit can be checked on the service tool.	
	Address record	Enter the set addresses in the check sheet.	
	Address hold check	Check whether or not the address setting is held by the service tool after indoor/outdoor circuit breakers were turned OFF to ON.	
Indoor unit connection check	Indoor unit connection check	Are the number of connecting indoor units correct ? Is the total capacity of indoor units correct ? < For the checking, Refer to the page 01-08 >	

[Note] Before connecting service tool, the address setting has to be completed.

Cooling test run	Outdoor unit push button SW operation	All the indoor units in the same refrigerant circuit shall enter the coolingtest run state. The outdoor units corresponding to the operation capacity of the indoor units shall operate. < Test operation procedure, Refer to the page 01-09,10 >	
All of the indoor units operation (after 30 mins)	<On service tool>		
	High pressure	HPS: 3.2 MPa	*
	Low pressure	LPS: 0.8 MPa	*
	Discharge pipe temperature (outdoor unit)	TH1: 92°C	*
	Suction pipe temperature (outdoor unit)	TH4: 15°C	*
	Inlet air temperature (indoor unit)	TH21: 27°C	*
	Heat exchange inlet temperature (indoor unit)	TH22: 11°C	*
	Heat exchange outlet temperature (indoor unit)	TH24: 13°C	*
	Compressor operation	Shall operate corresponding to the operation capacity of the indoor units.	
	Data output	Service tool used, output (CSV ⇒ Excel)	
	<Outdoor unit>		
	Outdoor Main PCB 7-seg. display	There shall be no Error information on the 7-segment display on the Main PCB.	
	Operation voltage	Between L - N AC230V (220-240V)	
	Abnormal sound/ abnormal vibration	These shall be no abnormal sound or abnormal vibration.	
		The outdoor fan shall not make a moaning sound.	
		There shall be no discharge air leaking from the outdoor duct.	
		There shall be no pipe chattering sound or flute sound generated.	
<Indoor unit service tool + actual measurement>			
Outlet air temperature	Inlet air temperature and outlet air temperature difference shall be 10°C or greater.		
Abnormal sound/abnormal vibration	There shall be no abnormal sound or abnormal vibration.		
Water leakage check	There shall be no water leakage. There shall be no condensation on the drain, cabinet, piping, and discharge port.		
Remote controller operation	Shall operate according to the settings. (ON-OFF, set temperature change)		

Procedure	Check contents	Judgement standard	Check
Indoor unit individual operation	<Indoor unit service tool + actual measurement>		
	Fan operation	Shall be switched to all fan speeds in the cooling mode.	
	Louver operation (except duct)	Louver shall be switched to all positions. Shall also swing.	
	Outlet air temperature	Inlet air temperature and outlet air temperature difference shall be 10°C or greater.	
	Abnormal sound/abnormal vibration	There shall be no abnormal sound or abnormal vibration.	
	Water leakage check	There shall be no water leakage. There shall be no condensation on the drain, cabinet, piping, and discharge port.	
	Remote controller operation	Shall operate according to the settings. (ON-OFF, set temperature change)	

*
 These are representative figures of AJ*054LCLAH at the standard condition. (Indoor : 27°C, Outdoor : 35°C)
 If conditions are different from those above mentioned, the figures will be changed slightly.
 It depends on following conditions.

- Outdoor unit capacity
- Indoor and outdoor temperature
- Indoor unit capacity
- Pipe length
- etc

Trouble shooting on Test run operation

1. Error occurred

- Check on the Error code on the Remote controller or Indoor unit or Outdoor unit or Service tool and check the description of the Error code.
 < Refer to the Trouble shooting in the Service manual.>
 < Refer to the Execution of precautions 1-1 and Check item Before power ON 1-2-1>

2. No good performance without error code

- Check if the protection controlling is operating or not
 Evaporator Icing up protection, High discharge temperature protection, etc.
 < Refer to the part of protection controlling in the Service manual >
- Check on the refrigerant circuit
 Refrigerant amount, Pipe blockage, Wrong position of separation pipes etc.
 < Refer to the Execution of precautions 1-1 and Check item Before power ON 1-2-1>
 < Refer to the regulation of installation in the Installation manual>

1-2-3 Automatic address setting for signal amplifiers

When using signal amplifiers

● SWITCH POSITION

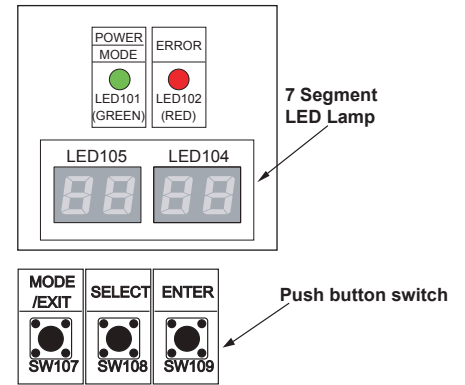
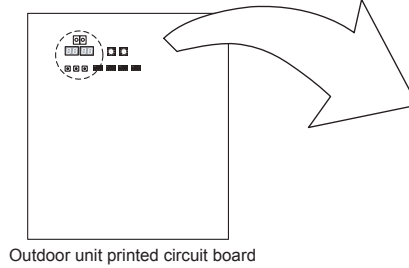

When setting the address of the signal amplifier, please use the factory setting. (See the installation manual of the signal amplifier)

When the system is normal, nothing will be displayed on the 7 segment display.

When ERROR is displayed, inspect the units.

Use the "MODE/EXIT", "SELECT", and "ENTER" buttons on the outdoor unit Main PCB to configure settings according to the procedures below.

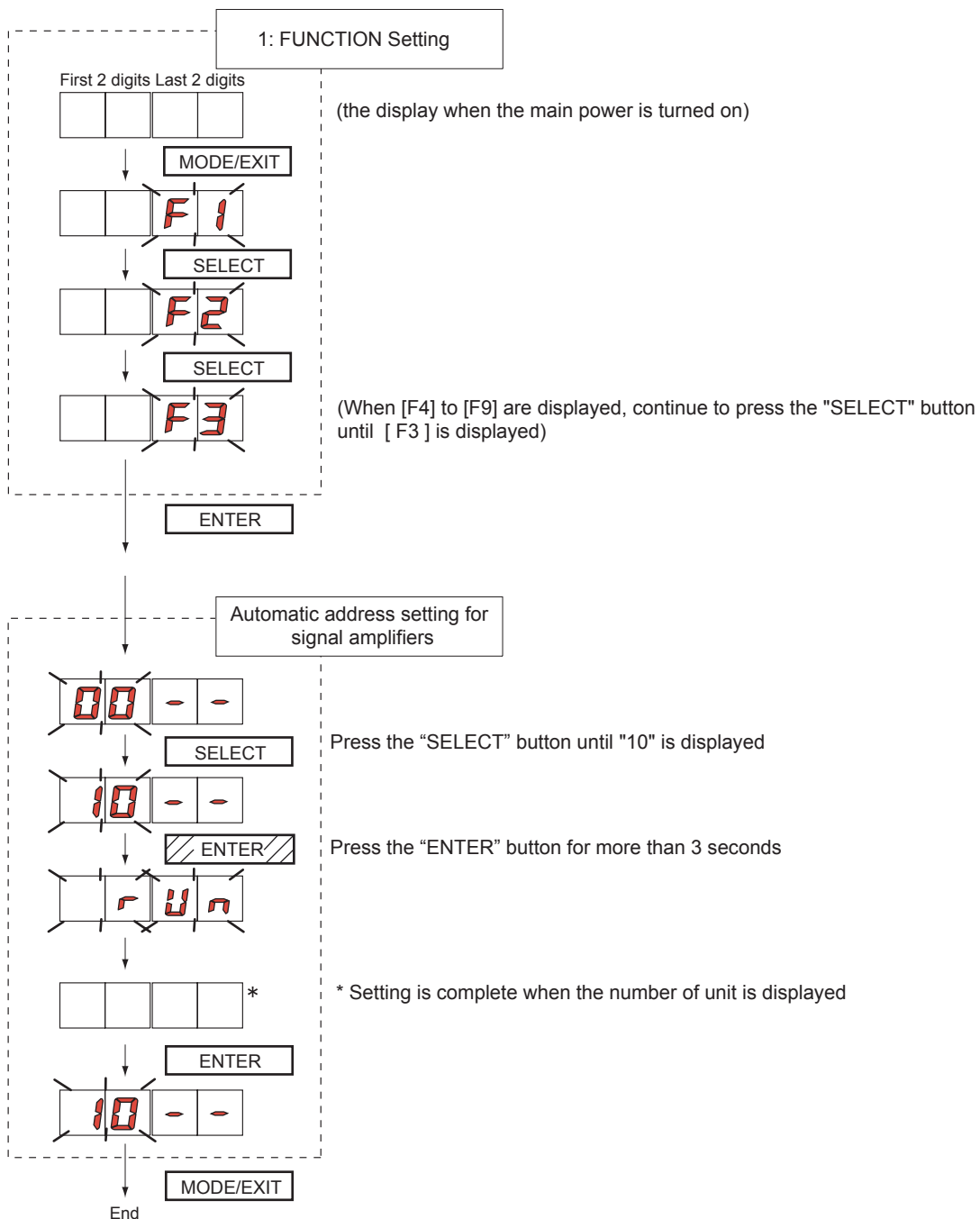

1-2-4 Automatic address setting for Indoor units

● SWITCH POSITION

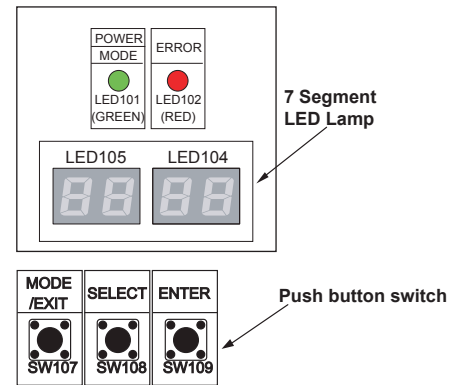
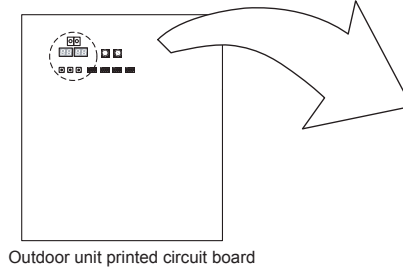

Check that the rotary switch IU AD on the indoor unit Main PCB is set to "00". If it is not set to "00", it means the address of that device is not set. (Factory default is "00").

Turn on the power of the indoor and outdoor units.

When the system is normal, nothing will be displayed on the 7 segment display.

When ERROR is displayed, inspect the units.

Use the "MODE/EXIT", "SELECT", and "ENTER" buttons on the outdoor unit Main PCB to configure settings according to the procedures below.

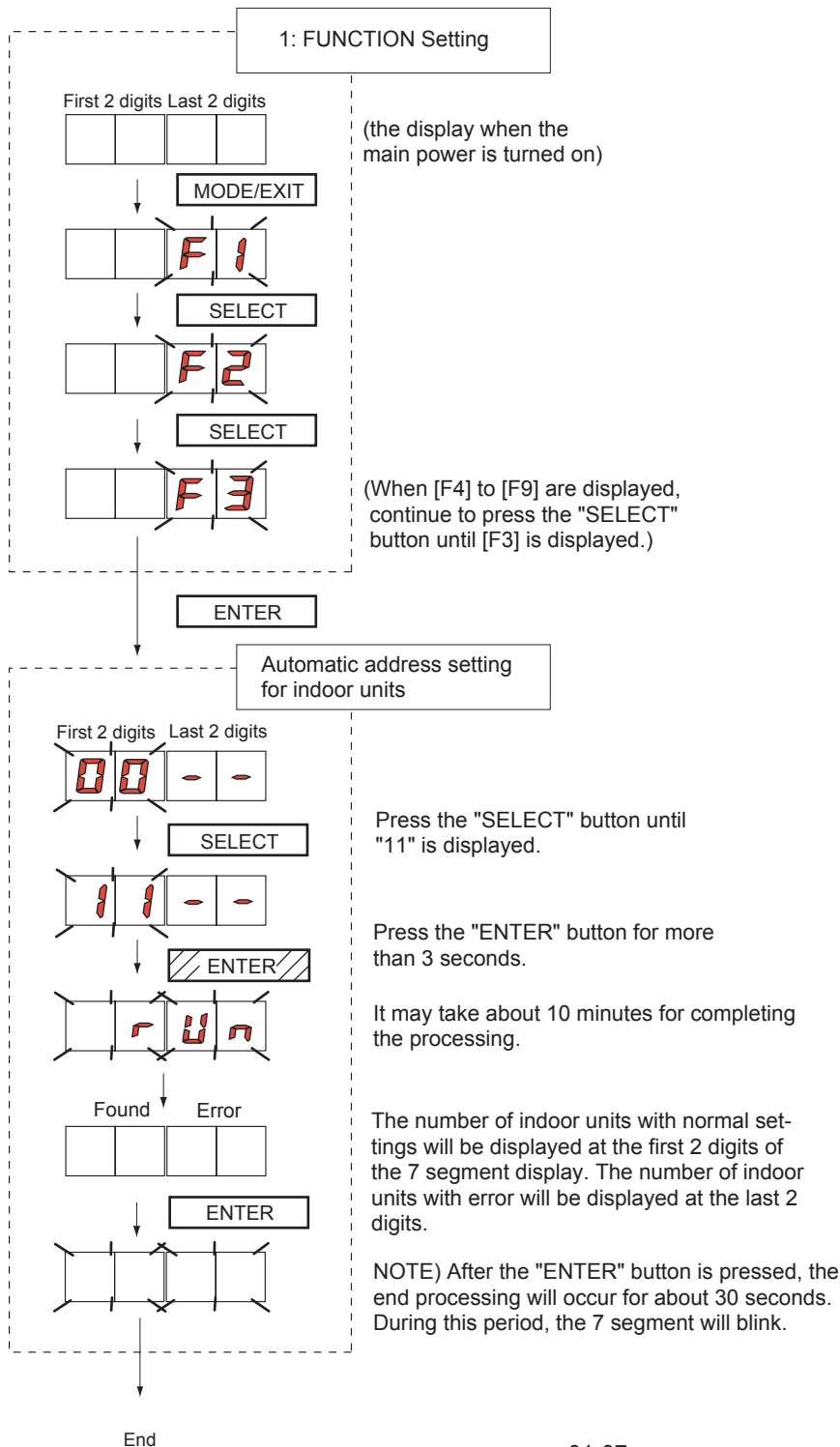

1-2-5 Indoor unit connection check

● SWITCH POSITION

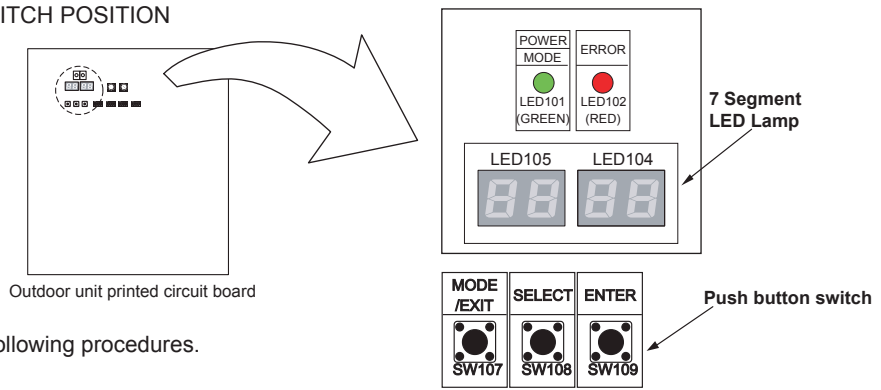

Please perform the indoor unit connection check according to following procedures.

- Turn on the power of indoor unit and outdoor unit.

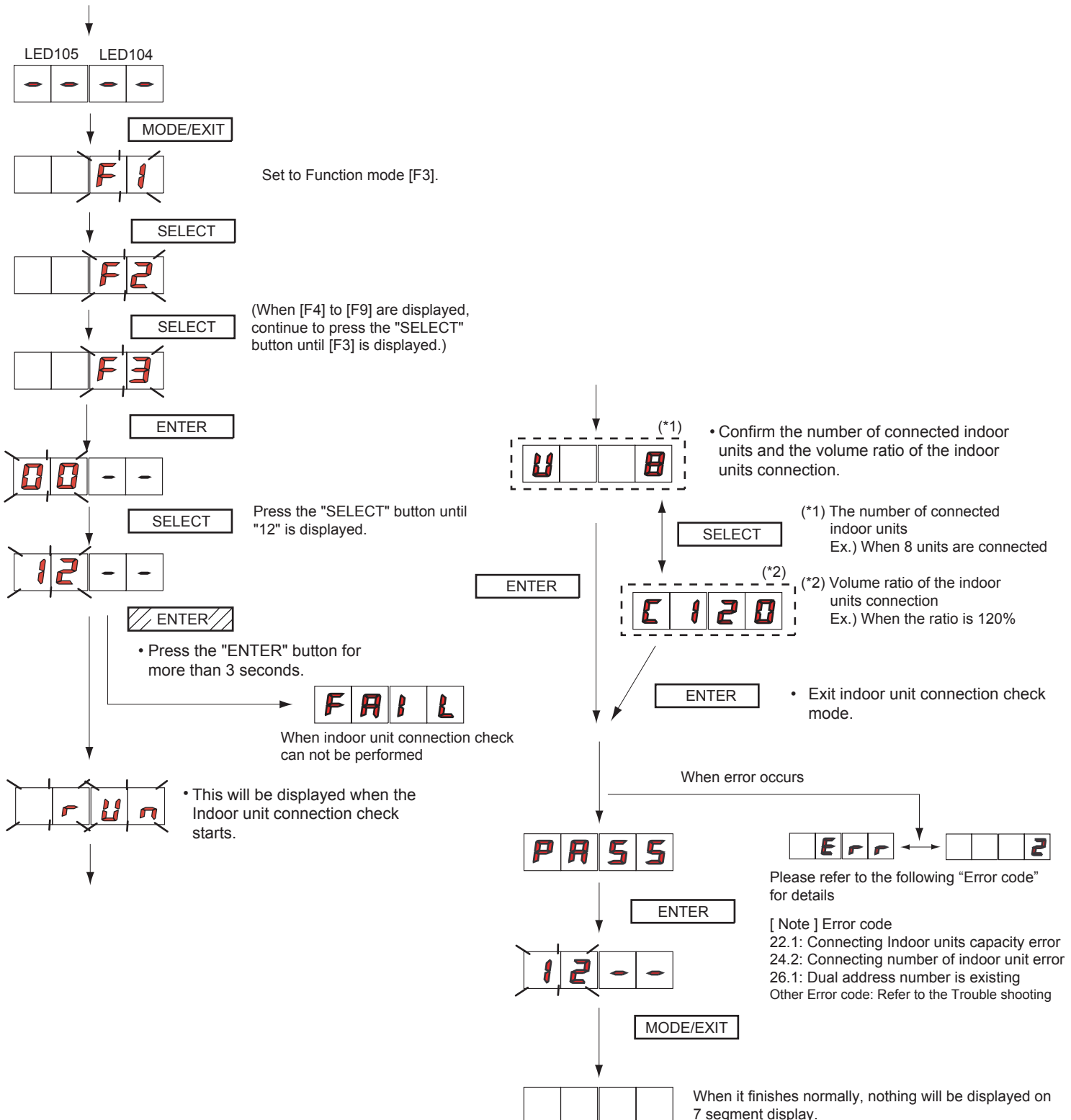

1-2-6 Test Run From Outdoor Main PCB

All the indoor units connected to the outdoor unit can be test-operated by push button setting.

● SWITCH POSITION

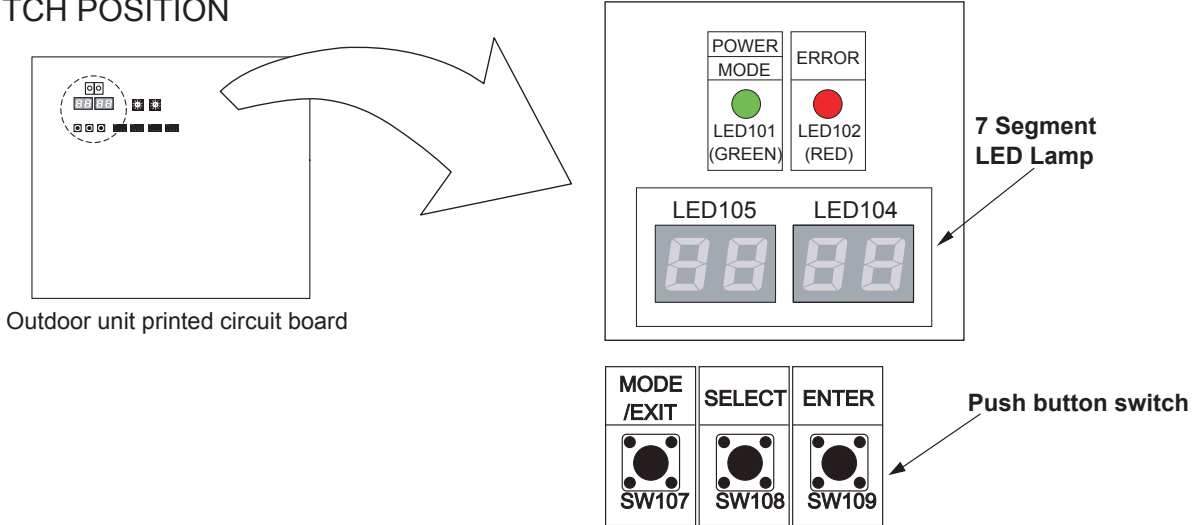

● TEST RUN SETTING

For a detailed description of push button operation, refer to the [D&T manual Chapter 6. SYSTEM DESIGN]

< Monitoring condition >

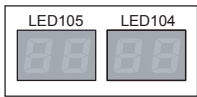

< Mode select condition >

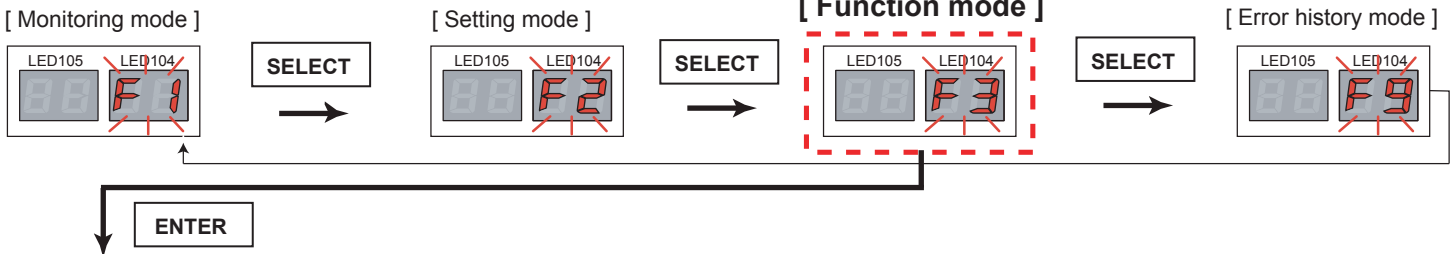

< Function select condition >

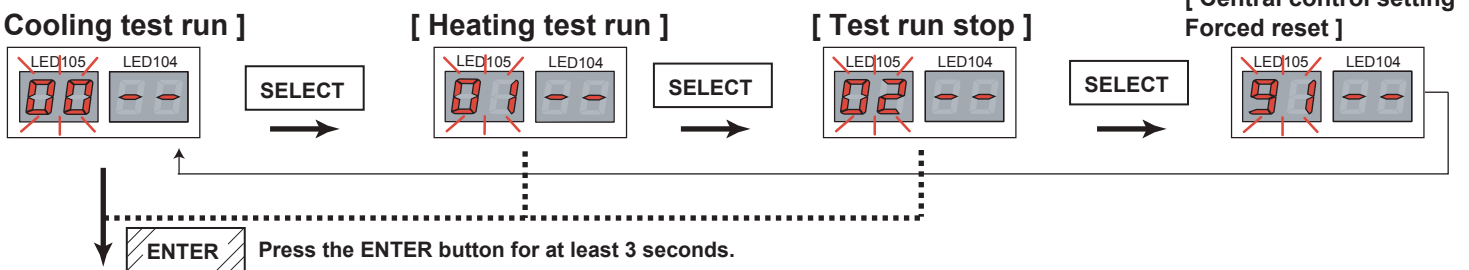

< Pursuance completion >

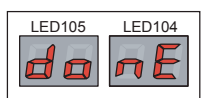

< Return to mode select condition >



< Return to monitoring condition >

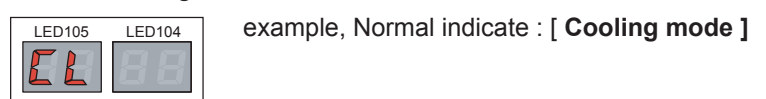

Note

There are the following 2 methods of resetting test operation.
 (1) Automatic reset when 60 minutes has elapsed.
 (2) Reset when operation stop was performed.

1-2-7 Test Run From Remote Controller

1. Wired remote controller (2 wire type) : UTY - RNR *

[Maintenance]

Carry out the following setting and confirmation, as required.

1. Touch the [Menu] on the "Monitor mode screen". The "Main Menu" screen is displayed.
2. The "Main Menu" screen has two pages. Touch [Next Page] or [Previous Page] to switch between screens. Then touch the [Maintenance].

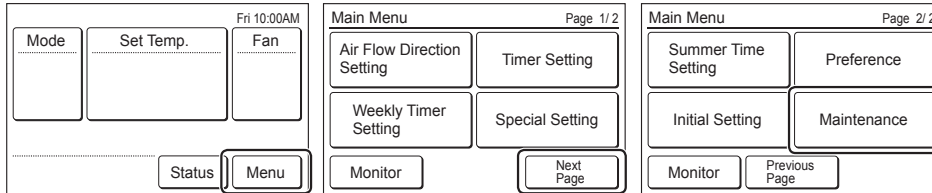

3. The "Maintenance" screen is displayed. Touch [Next Page] to switch the page 2. And touch the [Test Run].

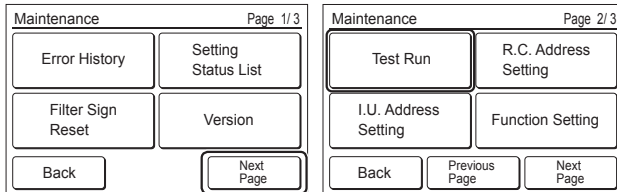

[Test Run]

Carry out a test run after completing configuration.

4. Touch the [Test Run] on the "Maintenance" screen. The "Test Run" screen is displayed. Touch [OK] to return to the Maintenance screen, and start a test run. The test run will automatically end in approximately 60min.

If you wish to cancel the test run before it is complete, return to the "Monitor Mode screen", and touch the On/Off button.

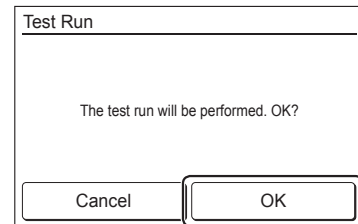

2. Wired remote controller (2 wire type) : UTY -RLR *

[Menu 2 setting]

1. With "Monitor Mode Screen" displayed, press and hold the [MENU] button, [<] button and [ENTER] button simultaneously for at least 2 seconds. Setting item selection screen is displayed.
2. Select the number of the item to be set with the [<] or [>] button; press the [ENTER] button to switch to the Setting Screen. Please refer to the table below for the settings of each part number. For details concerning settings, see the description of the setting concerned.

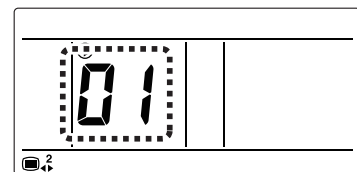
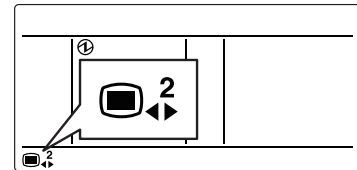

[Test Run]



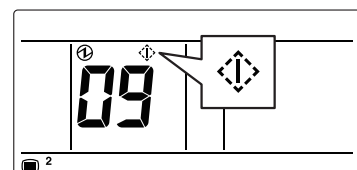
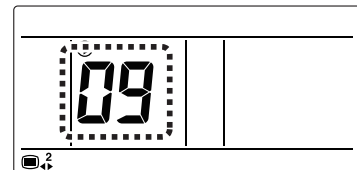

3. Select the "09" in Menu 2 Settings. Then press the [ENTER] button.
4. The test operation screen is displayed. Press the [ENTER] button to return to the Menu 2 item selection screen, and test operation begins.



Test operation is completed after about an hour.

To quit test operation before it is complete, return to the "Monitor Mode Screen" and press the On/Off button.

3. Standard wired remote controller

Stop the indoor unit. Push the  button and  button simultaneously for more than two seconds. The air conditioner will start to conduct a test run and "0 !" will display on the remote controller display. However, the ,  setting button does not have function, but all other buttons, displays, and protection functions will operate.

- Perform the test operation for 60 minutes.
- To stop test run, push the START / STOP button of the standard wired remote controller.
- For the operation method, refer to the operating manual and perform operation check.
- Check that there are no abnormal sounds or vibration sounds during test run operation.

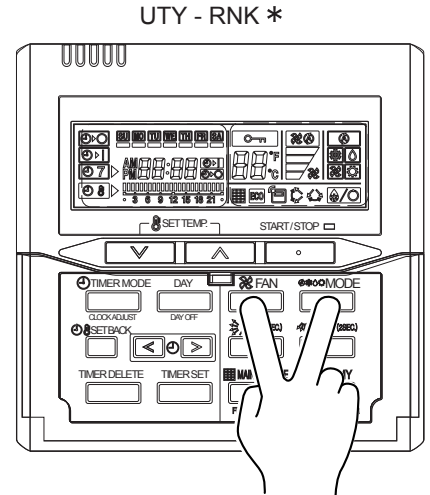



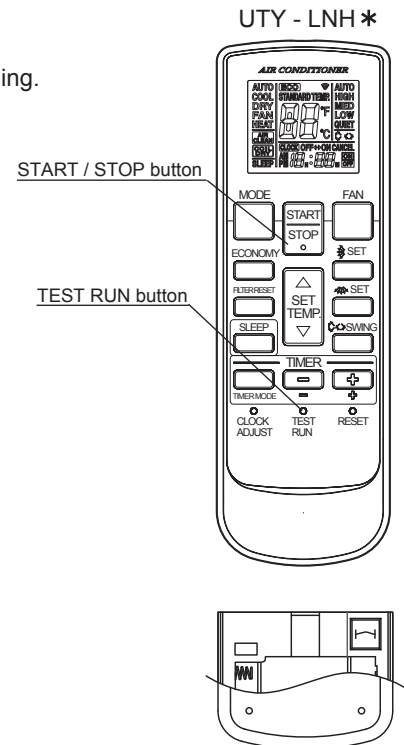

4. Standard wireless remote controller

- Press the TEST RUN button on the remote controller, while the air conditioner is running.
- To end test run operation, press the remote controller START / STOP button.

When the air conditioner is being test run, the OPERATION and TIMER lamps of indoor unit flash slowly at the same time.



5. Simple remote controller

Stop the indoor and outdoor units. Push the remote controller  button and  button simultaneously for more than three seconds. The air conditioner will start to conduct a test run and "0 !" will display on the temperature display. However the ,  setting button does not have function but all other buttons, displays and protection functions will operate.

- To stop test running press the  button of the simple remote controller.
- For the operation method refer to the operating manual and perform operation check.
- Check that there are no abnormal sounds or vibration sounds during test run operation.

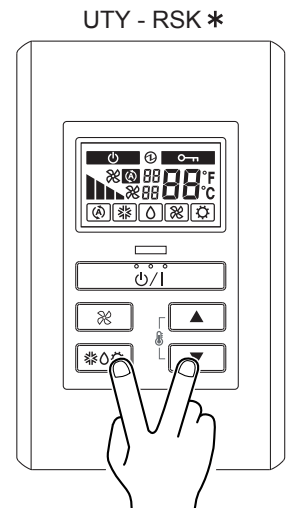

6. Central remote controller

Test run operating procedure

<Monitor screen: 9 units display>

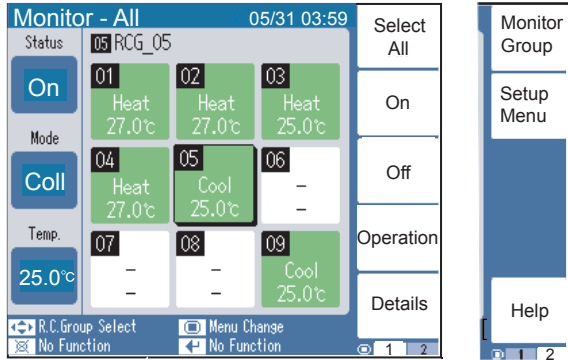

- 1) Press  Button
- 2) Press the [Setup Menu (F2)] button.



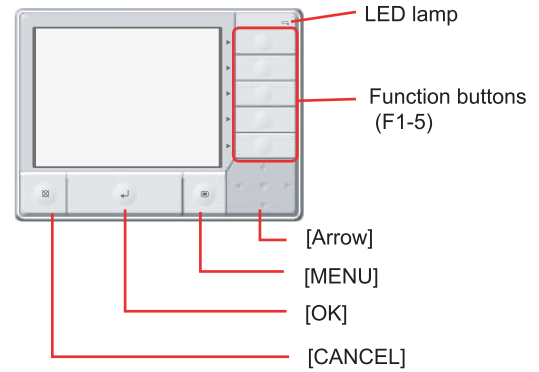

UTY-DCG *

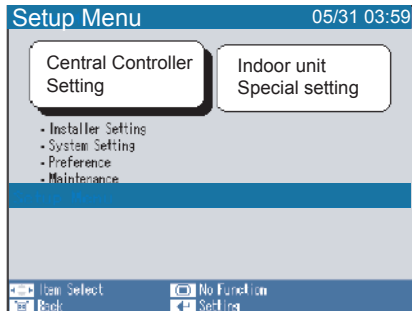

< Password verification >

- 3) Shift the Indoor unit special setting by pressing the [] button and [] button



- 4) Shift the Test Operation by pressing the [] button and [] button

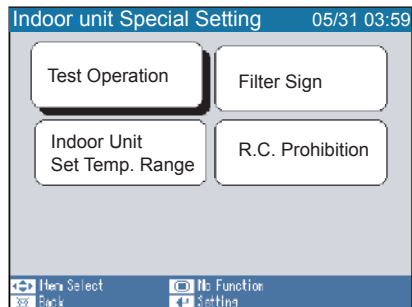

- 5) Press the [Select All (F2)] button or [Identify Unit (F3)] button

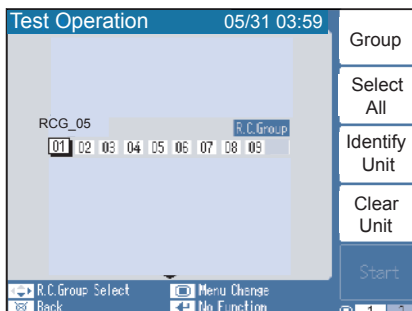

[Select All (F2)]: All of R.C.Group (Indoor units)
 [Identify Unit (F3)] : Specific R.C.Group (Indoor unit)

- 6) Press the [Start (F5)] button.

7. Touch panel controller

UTY - DTG*

Test run operating procedure

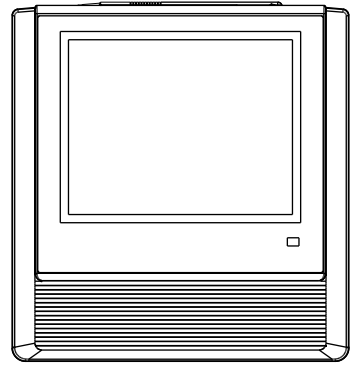

<Monitor screen (icon)>

Monitor Mode 10/11.2008.Mar. 02:20 PM Status: On

All Lange Group

Office A On Cool 21.5°C	Office B On Heat 21.0°C	PC Room On Cool 26.0°C
Room 101 Off	Restrant On Auto 24.0°C	Entrance On Auto 24.0°C
Meeting 1 On Heat 21.5°C	Meeting 2 Off	Meeting 3 On Heat 21.0°C
Conference A On Heat 21.5°C	Conference B On Auto 22.0°C	Parking lot Off

Setting
Schedule
Select All (1)
Clear All
Operation (2)
On
Off (*)

<Monitor screen (list)>

Monitor Mode 10/11.2008.Mar. 02:20 PM Status: On

All Lange Group

Name	Expand	Status	Mode	Set Temp	Fan	R/C Prohibit
Office A		On	Heat	21.5°C	High	All
Office B		Mixed	Mixed	Mixed	Mixed	Mixed
PC Room		On	Auto	24.0°C	Low	All
Room 101		Off				All
Restrant		On	Cool	26.0°C	Auto	
Entrance		Off				
Meeting 1		Off				

Setting
Schedule
Select All (1)
Clear All
Operation (2)
On
Off (*)

(1) Select the objective you want to test run.

Select the objective icon or list at the monitor screen. (Multiple selections is possible)

Select all the devices registered as objectives by pressing "Select All" on the monitor screen.

(2) After objective selection at (1), switch to the <Setting screen> by pressing "Operation".

<Setting screen>



(3) Switch to the <Details setting screen> by pressing "Optional Setting" on the setting screen.

<Details setting screen>

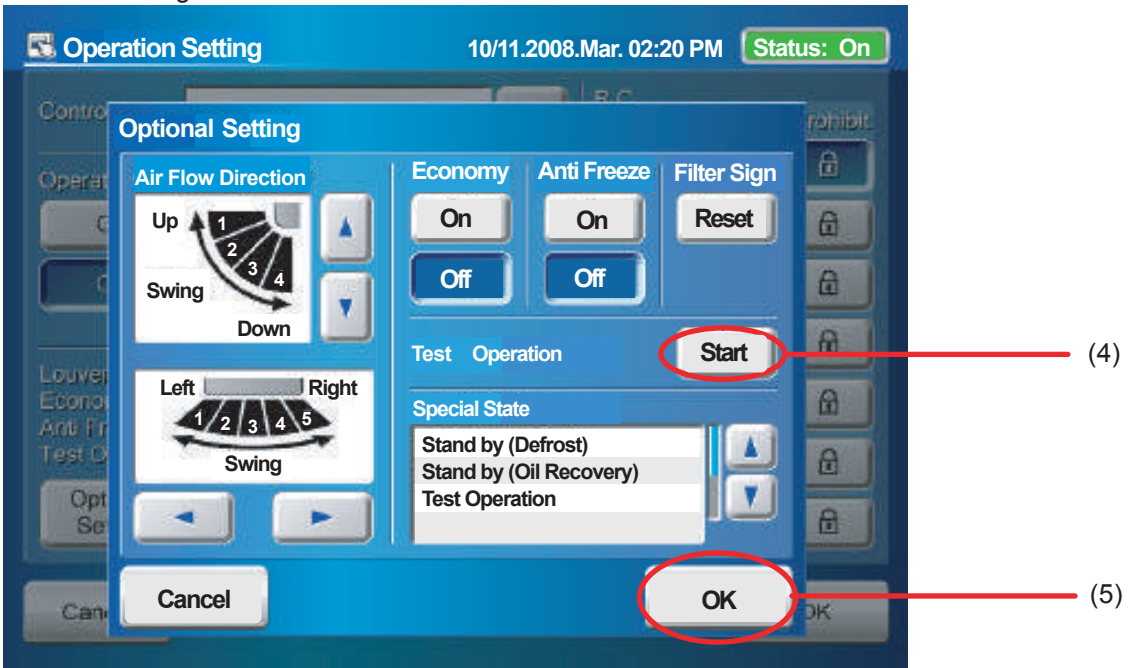

(4) Send (start) test run by pressing "Start" and then pressing "OK" on the details setting screen. Test run continues for 60 minutes. During sending, the slave screen shown below is displayed. When sending is completed, the sending slave screen and details setting screen are closed.

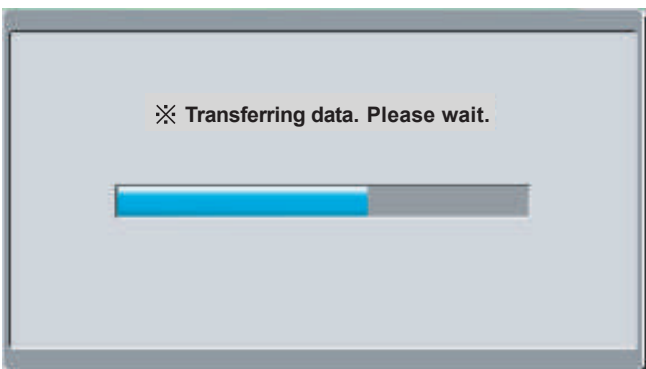

To interrupt test run, select the device being test run and execute an operation stop command.

- (*) At the monitor screen, test run is reset by stopping operation of the objective devices by pressing "OFF".
- (*) Or test operation is reset by stopping operation of the objective devices by pressing "Off" of Operation and then pressing "OK" on the setting screen.

1-3 TEST RUN CONTROL

1. When the test run signal is transmitted from standard wired, wireless remote controller, simple remote controller, transmitted network, and outdoor unit.

- (1) The test run operation starts and the electric expansion valve is controlled to a maximum flow, regardless of the temperature condition.
- (2) Frost prevention operation has priority over item(1).
- (3) Whether state of the indoor unit operates or stops, All units in the same refrigerant circuit will start to conduct a test run in accordance with the operation mode set by push switch of outdoor unit (see 1 - 2 - 3).
- (4) After 60 minutes passes, the test run stops.
- (5) Test running initialization is shown below.

Operating Mode	EXCEPT FOR THE DUCT MODEL		DUCT TYPE	
	Cooling	Heating	Cooling	Heating
Fan speed	Hi	Hi	Hi	Hi
Room Temperature Indication	18	30	18	30
Vertical Air Direction Panel	Position ①	Position ④	_____	_____
Swing	OFF	OFF	_____	_____

*Example



■ COMPACT CASSETTE TYPE

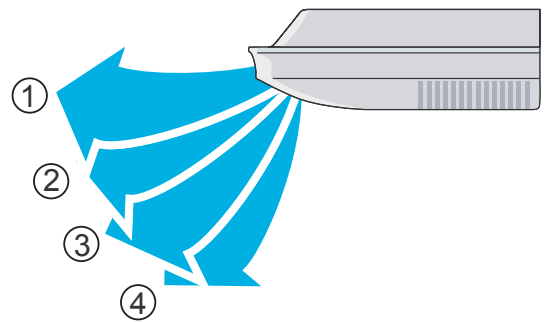

■ CEILING TYPE

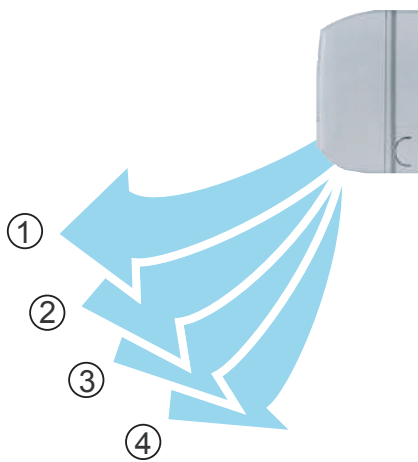

■ COMPACT WALL MOUNTED TYPE

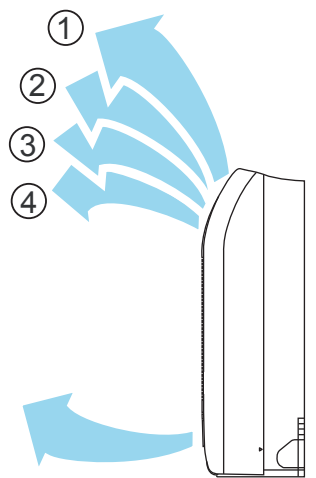
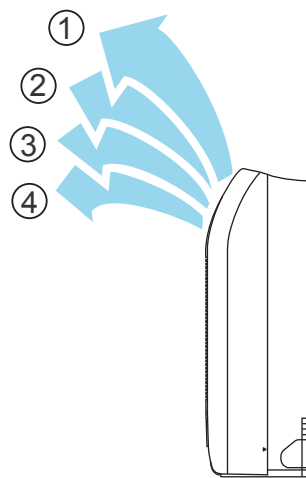

Set the air outlet selection switch to

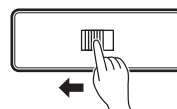

Set the air outlet selection switch to

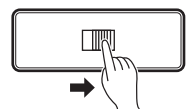

■ COMPACT FLOOR

1-4 Field Setting And Monitor Mode List for Outdoor unit

	Classification	ITEM CODE No.	Setting Mode	Information contents
Push switch on outdoor unit PCB Monitor mode [F1]	Device and system	00	Connected number of indoor unit	The number of the communicating unit is displayed
		01	Software version of outdoor unit	
		02	Software version of INV PCB	Software version : E●●●V○○☆■□L△△-◎
		03	Software version of communication PCB	[E●●●][V○○][☆■□][L△△][-◎] displays by five items It skips when there is no suffix「-◎」
	Operation of each part	10	Rotational speed of outdoor unit fan motor	The rotational speed of the outdoor unit fan motor is displayed [rpm]
		11	Rotational speed of INV compressor	The rotational speed of the compressor is displayed [rps]
		12	Current value of INV compressor	Current value of INV compressor is displayed [A]
		14	Pulse of EEV1	Pulse of EEV1 is displayed [pls]
	Time guard	20	Accumulated current time	Accumulated current time is displayed [×10 hour]
		21	INV compressor accumulated time [Cooling]	Accumulated time is displayed in the cooling operation of the INV compressor [×10 hour]
		22	INV compressor accumulated time [Heating]	Accumulated time is displayed in the heating operation of the INV compressor [×10 hour]
	Refrigerant cycle data 1	30	Information on Thermistor 1 (INV compressor discharge temperature)	The value of the Thermistor 1 is displayed [°C] or [°F]
		32	Information on Thermistor 3 (Outdoor temperature)	The value of the Thermistor 3 is displayed [°C] or [°F]
		33	Information on Thermistor 4 (Suction temperature)	The value of the Thermistor 4 is displayed [°C] or [°F]
		34	Information on Thermistor 5 (Heat-exchanger temperature)	The value of the Thermistor 5 is displayed [°C] or [°F]
		39	Information on Thermistor 10 (INV compressor temperature)	The value of the Thermistor 10 is displayed [°C] or [°F]
	Refrigerant cycle data 2	50	Information on pressure sensor 1 (High pressure sensor)	The value of the pressure sensor 1 is displayed [MPa] or [psi]
		51	Information on pressure sensor 2 (Low pressure sensor)	The value of the pressure sensor 2 is displayed [MPa] or [psi]

	Classification	ITEM CODE No.	Setting Mode	ITEM CODE No.	Setting Function	Default	
Push switch on outdoor unit PCB Setting mode [F2]	Install	00	Pipe length setting ⚠Setting is forbidden	00	Standard	○	
				01			
				02			
		Correction	10	Sequential start shift ⚠Setting is forbidden	00	Standard	○
					01		
					02		
			11	Cooling capacity shift	00	Normal mode	○
					01	Save energy mode 1 (+2°C)	
					02	High power mode 1 (-2°C)	
					03	High power mode 2 (-4°C)	
	04				High power mode 3 (-5°C)		
	12		Heating capacity shift	00	Normal mode	○	
				01	Save energy mode (-2°C)		
		02		High power mode 1 (+2°C)			
		03		High power mode 2 (+4°C)			
	13	Defrost setting shift	00	End temperature:Normal	○		
			01	End temperature:Higher			
	14	Pressure equalization time shift before defrosting start	00	No time shift	○		
			01	Shift 1 (30 sec.) ⚠Only for solution			
			02	Shift 2 (60 sec.)			
			03	Shift 3 (90 sec.)			
			04	Shift 3 (120 sec.)			
	16	Compressor lowest operation time setting	00	Standard	○		
			01	6 min. ⚠Only for solution			
			02	5 min.			
			03	4 min.			
			04	3 min.			
	Change of function 1	20	Switching between forced stop or emergency stop	00	Forced stop	○	
				01	Emergency stop		
		21	Operation mode selecting method	00	Priority given to the first command	○	
				01	Priority given to the external input of outdoor unit		
				02	Priority given to the master indoor unit		
		22	Snow falling protection fan mode ⚠Setting is forbidden	00	Normal operation	○	
				01			
		23	Interval setting for snow falling protection fan mode ⚠Setting is forbidden	00	Standard	○	
				01			
				02			
				03			
		24	High static pressure mode ⚠Setting is forbidden	00	Standard	○	
				01			
	02						
	25	Oil recovery ⚠Setting is forbidden	00	Standard	○		
			01				
			02				
			03				
	26	Oil recovery Abnormal low pressure protection control ⚠Setting is forbidden	00	Standard	○		
			01				
	27	Error code Notification	00	Enable	○		
			01	Disable			
	28	Change of unit (Temperature)	00	Celsius(°C)			
			01	Fahrenheit (°F)			
	29	Change of unit (Pressure)	00	MPa	○		
			01	psi			
	Change of function 2	30	Energy saving level setting	00	Level 1 (stop)	○	
				01	Level 2 (operated at 40% capacity)		
				02	Level 3 (operated at 60% capacity)		
				03	Level 4 (operated at 80% capacity)		
				04	Level 5 (operated at 100% capacity)		
	31	Heating Starting process ⚠Setting is forbidden	00	Standard	○		
			01				
	Low noise setting 1	40	Capacity priority setting (in low noise mode)	00	Off (quiet priority)	○	
				01	On (capacity priority)		
				02			
	41	Low noise mode setting	00	Off (Normal)	○		
			01	On (Low noise mode operation is always done)			
	Change of function 3	42	Low noise mode operation level ⚠Setting is forbidden	00	Standard	○	
				01	Lower		
	Change of function 4	60	Back up operation ⚠Setting is forbidden	00	Standard	○	
				01			
		61	⚠Setting is forbidden	00	On	○	
				01	Off		
		70	Electricity meter No. setting 1 (Set the ones digit and tens digit of the No of the electricity meter connected to CN135.) *3	00~99	Setting number x00~x99 (Refer to Design & Technical Manual for details.)	00	
	71	Electricity meter No. setting 2 (Set the hundreds digit of the No. of the electricity meter connected to CN135.) *3	00~02	Setting number 0xx~2xx (Refer to Design & Technical Manual for details.)	00		
	72	Electricity meter pulse setting 1 (Set the ones digit and tens digit of the No. of the electricity meter pulse setting connected to CN135.) *4	00~99	Setting number xx00~xx99 (Refer to Design & Technical Manual for details.)	00		
	73	Electricity meter pulse setting 2 (Set the hundreds digit and thousands digit of the electricity meter pulse setting connected to CN135.) *4	00~99	Setting number 00xx~99xx (Refer to Design & Technical Manual for details.)	00		

*3 : When electricity meter No. is set to "000" and "201 to 299", the pulses input to CN135 become ineffective. Available setting number is "001" to "200"

*4 : When the electricity meter pulse setting is set to "0000", the pulses input to CN135 become ineffective. Available setting number is "0001" to "9999"

⚠ Setting is forbidden: Any of problems caused by changing these setting is not covered by the warranty.

⚠ Only for solution : Only when the refrigerant noise during Defrosting was pointed out. It is the case that the compressor operating time in heating will be shorter.

		ITEM CODE No.	Setting Mode	Setting Function	
Push switch on outdoor unit PCB Function mode [F3]	Forced operation	00	Cooling test run	Forced thermostat-ON in Cooling.	
		01	Heating test run	Forced thermostat-ON in Heating.	
		02	Test run stop	Test run is stopped.	
	Install and maintenance 1	10	Signal amplifier automatic address	Automatic address setting operates for signal amplifier.	
		11	Indoor unit automatic address	Automatic address setting operates for indoor unit of same refrigerant circuit.	
		12	Indoor unit connection check	The number of indoor units and the total capacity of indoor units of same refrigerant circuit.	
	Install and maintenance 2	21	Vacuuming mode	Vacuuming mode operatesRefer to page 01-01 for the function.	
	Clear	30	Error history clear	All the abnormal code histories are cleared.	
		32	Current time clear	Accumulated current time becomes [0]	
		33	INV compressor accumulated time clear	Accumulated time of the INV compressor becomes [0]	
		34	Constant Speed compressor accumulated time clear	Not in Use on J-Series	
		35	Field setting all clear	Return to default the all set items.	
		36	Clear memorized information of "F3 - 12 " (Indoor unit connection check)	The information of the number of indoor units and the total capacity of indoor units are cleared.	
	Reset	40	Abnormal reset *	It was displayed when abnormality occurs, and abnormal code is reset. This is a function that uses to clear abnormal display after the repair is completed. Please operate the switch after power off or power on the outdoor unit.	
		41	Maximum memorized indoor unit number reset	Maximum memorized indoor unit number is reset. "E14.5:Indoor unit number shortage" error is cleared.	
		90	Foreced Normal operation release	Normal operation foreced release	
	Specialtyfunction	91	Foreced Central control function release	When the centralized control device failure, and the centralized control setting cannot be released, this function is used. All the limitations set with the centralized control device are released.	
			ITEM CODE No.	Meaning of Error History Number	Information contents
	Push switch on outdoor unit PCB Error History Mode [F9]	Error history	00	1 time ago (Newest)	When the error occurred, the error code is memorized up to 10 on Main PCB.
			01	2 times ago	
02			3 times ago	If the memorized error code becomes over 10, the oldest one will be erased.	
03			4 times ago		
04			5 times ago		
05			6 times ago		
06			7 times ago		
07			8 times ago		
08			9 times ago		
09			10 times ago (Oldest)		
				Refer to Chapter 4.TROUBLE SHOOTING 4-2-3 Error Code List of Outdoor unit	

*< Reset Error Item List By Abnormal Reset Setting >

- Compressor Motor Loss of Synchronization
- Compressor 1 Temperature Abnormal
- Inverter Compressor Start Up Error
- Discharge Temperature 1 Abnormal
- Low Pressure Abnormal
- Current Sensor 1 Error
- Trip Detection
- Rush Current Limiting Resistor Temp Rise Protection
- Outdoor Unit FAN motor Lock Error

1-5 Field Setting / Function Setting for Indoor unit

	Classification	ITEM CODE No.	Setting Mode	ITEM CODE No.	Setting Function	Default
Indoor unit field setting setting by remote controller	Address	01	Indoor unit address	00~63	00~63	00
		02	Refrigerant circuit address	00~99	00~99	00
	Filter	11	Filter indicator Interval	00	Default	○
				01	Longer	
				02	Shorter	
		13	Filter sign display	00	Enable	○
				01	Disable	
	02			Display only on central remote control		
	Airflow	20	Ceiling airflow (Cassette type only)	00	Default	○
				01	High ceiling	
		23	Vertical airflow direction	00	Default	○
				01	Raise	
		24	Horizontal swing airflow direction	00	Default	○
				01	Left half	
				02	Right half	
		26	Static Pressure setting - Slim Duct Only - The Range of static pressure is different from one model to other.	00	0 Pa	
				01	10 Pa	
				02	20 Pa	
				03	30 Pa	
				04	40 Pa	
				05	50 Pa	
	06			60 Pa		
	07			70 Pa		
	08			80 Pa		
	09			90 Pa		
	31			25 Pa	○	
	Correction	30	Cool air temperature trigger	00	Default (0°C)	○
				01	Temperature overshoot setting (+2°C)	
				02	Temperature undershoot setting (-2°C)	
		31	Heat air temperature trigger	00	Default (0°C)	○
				01	Temperature undershoot setting (-6°C)	
				02	Temperature slightly undershoot setting (-4°C)	
	32	Temperature correction in Auto	00	Disable	○	
			01	Enable (Nonfunctional on J2 Series)		
	Change of Function 1	40	Auto restart	00	Enable	
				01	Disable	○
		43	Cool air prevention	00	Enable	○
				01	Disable (Ventilation mode)	
		46	External control	00	Start / Stop	○
				01	Emergency stop	
		47	Error report target	00	All	○
				01	Display only for central remote control	
		49	FAN Setting when cooling thermostat OFF *1	00	Follow the setting on the remote controller	○
				01	Foreced stop	
	90	Auto Louver Grille setting - Slim Duct Only -	00	Without Auto Louver Grille	○	
			01	With Auto Louver Grille		

*1: Fan Setting when cooling thermostat OFF, Connection of the wired remote controller (2-wire type or 3-wire type) and switching its thermistor are necessary.

1-6 Field Setting / Function Setting for Outdoor air unit

	Classification	ITEM CODE No.	Setting Mode	ITEM CODE No.	Setting Function	Default			
Indoor unit field setting setting by remote controller	Address	01	Indoor unit address	00~63	00~63	00			
		02	Refrigerant circuit address	00~99	00~99	00			
	Filter	11	Filter indicator Interval	00	Default	○			
				01	Longer				
				02	Shorter				
		13	Filter sign display	00	Enable				
				01	Disable	○			
	02	Display only on central remote control							
	Airflow	26	Static Pressure setting - Outdoor air unit Only - The Range of static pressure is different from one model to other.	05	SP mode 05				
				06	SP mode 06				
				07	SP mode 07				
				08	SP mode 08				
				09	SP mode 09				
				10	SP mode 10				
				11	SP mode 11				
				12	SP mode 12	Model name	Range of static pressure	Normal static pressure	
				13	SP mode 13				ARXH054GTAH ARQH140GTAH
				14	SP mode 14	ARXH072GTAH ARQH224GTAH	SP mode 05 to 20 (50 to 200 Pa)	200 Pa	
				15	SP mode 15				
				16	SP mode 16	ARXH096GTAH ARQH280GTAH	SP mode 05 to 22 (50 to 220 Pa)	200 Pa	
				17	SP mode 17				
				18	SP mode 18				
				19	SP mode 19				
				20	SP mode 20				
				21	SP mode 21				
				22	SP mode 22				
				31	Normal SP			○	
				Change of Function 1	40	Auto restart *1	00	Enable	
							01	Disable	○
					43	Cool air prevention	00	Super low	
	01	Follow the setting on the remote controller	○						
	02	Foreced stop (Start/Stop by RC is restricted)							
	46	External control	00		Start / Stop	○			
			01		Emergency stop				
	47	Error report target	00		All	○			
01			Display only for central remote control						
63	Humidifier control *2	00	mode 00		○				
		01	mode 01						
		02	mode 02						

*1: Auto restart is an emergency function such as for power failure etc.

Do not start and stop the indoor unit by this function in normal operation.

Be sure to operate by the control unit, converter or external input device.

*2: Select control conditions of external output.

"Mode 00" is output when heating thermostat is ON, "Mode 01" is output in heating operation, "Mode 02" is output in heating operation and in fan operation.



AIRSTAGE™ J-IIS

Variable Refrigerant Flow System

2. OUTDOOR UNIT OPERATION CONTROL

2. OUTDOOR UNIT

2-1 INPUT / OUTPUT LIST

		Input / output or kind of detail	Control range
I N P U T	Discharge pressure sensor <HIGH> Suction pressure sensor <LOW> Discharge temperature sensor <TH1> Outdoor temperature sensor <TH3> Suction temperature sensor <TH4> Heat exchanger temperature sensor <TH5> Compressor temperature sensor <TH10> Operation current sensor	Pressure sensor Pressure sensor Themistor <Blue> Themistor <- -> Themistor <Red> Themistor <Pink> Themistor <- -> Current transformer	Measure range 0.0 to 5.0MPa Measure range 0.0 to 1.7MPa Measure range 10 to 130°C Measure range -25 to 58°C Measure range -35 to 70°C Measure range -35 to 70°C Measure range 10 to 130°C
	Rotary SW & DIP-SW & Push SW	Address and function setting	
O U T P U T	Compressor Electronic expansion valve Fan motor 4-way valve Solenoid valve Crank case heater Base heater	Magnetic relay EEV coil DC Brushless motor 4-way valve coil Comp pressure equalizing valve For Inverter Compressor Field supply	Operation coil AC220-240V, 50Hz Operating voltage DC12V AC220-240V, 50/ 60Hz 4.5 /3.5 W AC220-240V, 50/ 60Hz, 5/ 4.5W AC240V, 21W AC220-240V, 35W
Communication Input / Output	LON WORKS Inverter communication	Indoor unit ↔ Outdoor unit	
External Input / Output	External input 1 (CN131) (Low noise mode operation) External input 2 (CN132) (Cooling / Heating priority) External input 3 (CN133) (Outdoor unit operation peak control) External input 4 (CN134) (Emergency stop operation)	Dry contact input	
	External output 1 (CN136) (Error display) External output 2 (CN137) (Operation display)	ON (Error) / OFF (Normal) ON (Operation) / OFF (Stop)	Control output: DC 0/12-24V, Max.30mA Control output: DC 0/12-24V, Max.30mA
LED display	Single LED 101 Single LED 102 7 Segment LED	Display the information on operation, error and setting with single LED and 7 segment LED.	

2-2 COMPRESSOR OPERATION

2-2-1 Operation / Stop Condition

When cooling requirement capacity or heating requirement capacity from either of the indoor units in the same refrigerant circuit is input, the compressor operates.

When all the indoor units in no "cooling requirement capacity" or "heating requirement capacity", the compressor is stopped.

But in the following case, the compressor operates in accordance with operation of each mode.

- During 3 minute restart prevention operation
- Icing protection
- Failure (Refer to chapter 4, TROUBLE SHOOTING)
- Oil recovery
- Under expansion valve initialization
- At protective operation
- Emergency stop
- Defrost operation
- Peak cut stop operation

2-2-2 Capacity Control

(1) Capacity of compressor operation

By the operation of DC inverter rotary compressor, the amount of required refrigerant circulation according to cooling and heating load can be supplied from compressor efficiently.

DC inverter rotary compressor is able to control the amount of required refrigerant circulation in details.

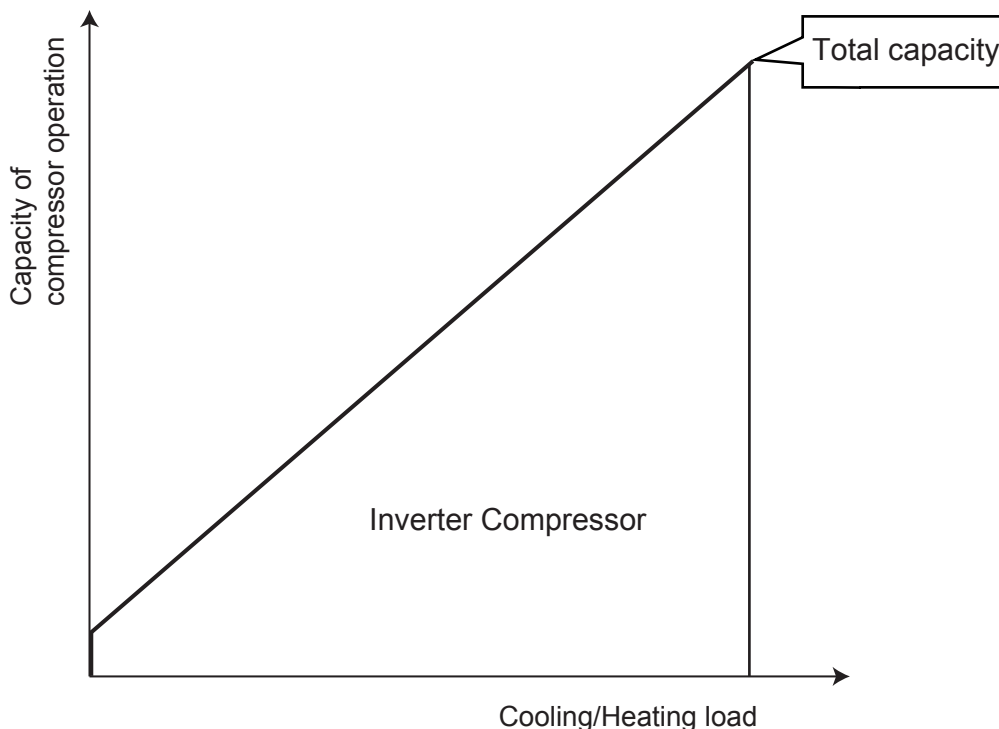

(2) Target low-pressure and high-pressure control

<Cooling>

In order to make the evaporation pressure of the indoor unit at the proper pressure on a variety of operations, capacity of the compressor will be controlled by low-pressure sensor of the outdoor unit.

<Heating>

In order to make the condensation pressure of the indoor unit at the proper pressure on a variety of operations, capacity of the compressor will be controlled by high-pressure sensor of the outdoor unit.

Target low-pressure and high pressure temperature depends on system capacity, capacity of compressor operation, pipe length, and capacity shift switch settings.

2-2-3 Speed Range of Start, Stop, And Operation

- On stop mode : 0 rps
- On operating mode : 20 - 110 rps

(1) Cooling starting process

- For cooling operation only, the upper limit speed at starting is made 60rps and is raised in +10rps increments every 60 seconds.
- The compressor operates at the upper limit speed if the target speed is higher than the upper limit speed.
- The compressor operates at the target speed if the target speed is lower than the upper limit speed.

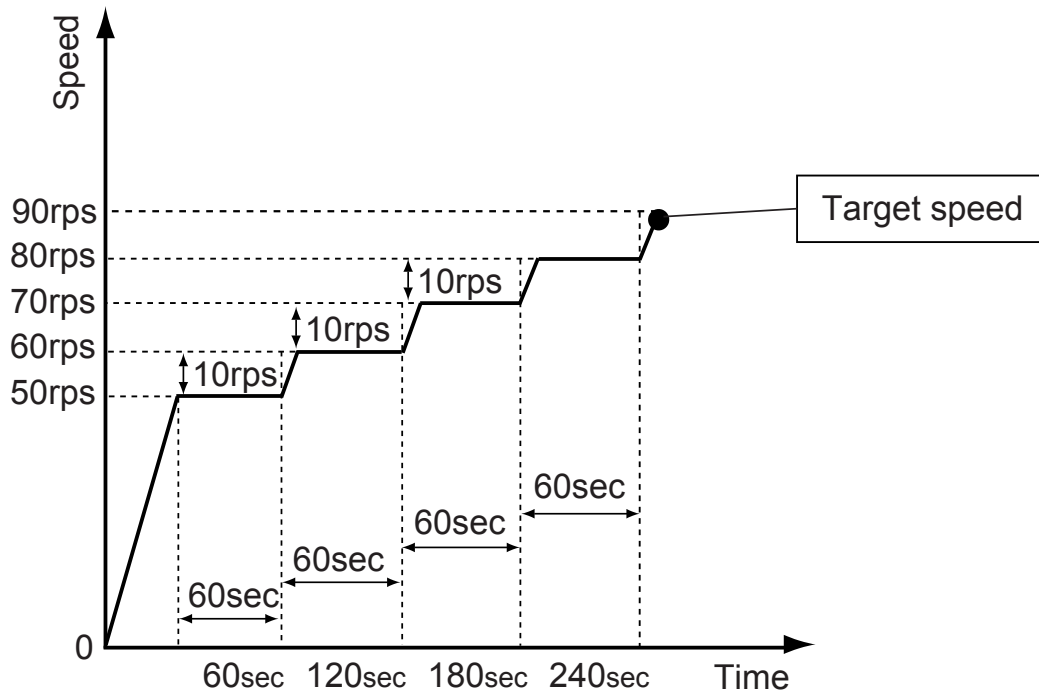

(2) Heating starting process

At the start of heating, the compressor is started by the following process. Compressor start-up to change the 4 way valve. Capacity control returns to normal control after the end of the starting process. (target high-pressure control)

< Starting process >

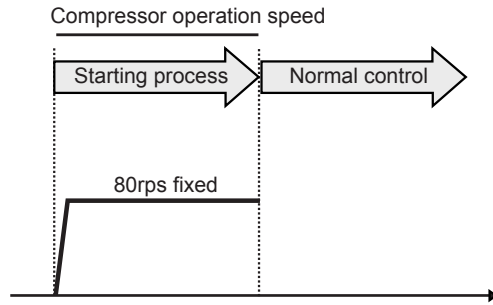

	Cancel conditions
Starting process	3 minutes have passed. and Discharge SH $\geq 8^{\circ}\text{C}$ or Compression ratio ≥ 9 or High-pressure $\geq 3.0\text{MPa}$ or 20 minutes have passed.

*However, when the following condition (A) or (B) are satisfied, starting process is not performed.

< Conditions under which starting process is not performed >

- (A) The compressor temperature $\geq 32^{\circ}\text{C}$, when the room temperature reached to the setting temperature (Thermostat - OFF controlling)
- (B) The compressor temperature $\geq 32^{\circ}\text{C}$, when the system keeps heating mode with stop condition

< Operation >

Compressor operates based on the required capacity at the start up, after that the target high-pressure control begins.

(3) Limits the upper limit speed of the INV compressor according to the present high-pressure value.

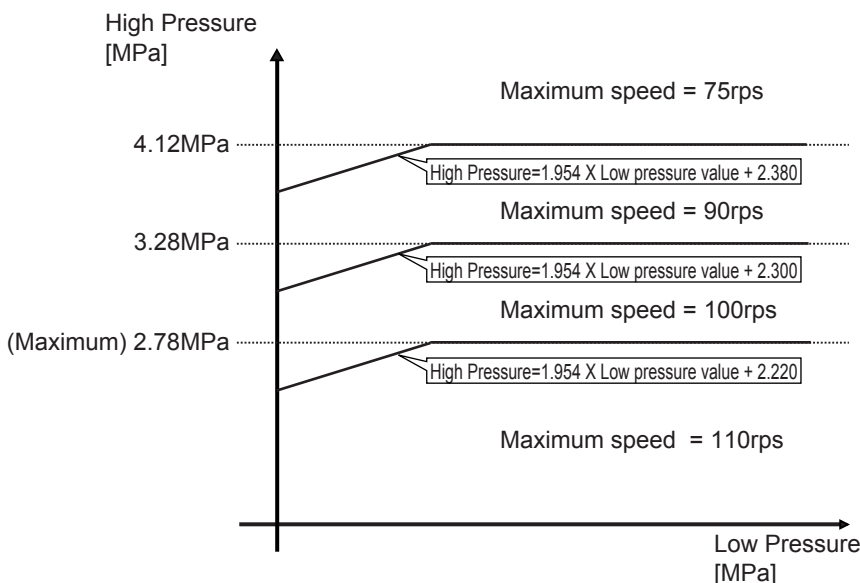

2-3 FAN CONTROL

2-3-1 Cooling Operation

Fan step	Fan speed (rpm)		
	AJ*040LCLAH	AJ*045LCLAH	AJ*054LCLAH
11	890	890	890
10	800	830	830
9	710	710	710
8	640	640	640
7	580	580	580
6	520	520	520
5	460	460	460
4	390	390	390
3	340	340	340
2	290	290	290
1	*intermittent	*intermittent	*intermittent
0	0	0	0

* intermittent operation : Repeat the cycle of 0 rpm (14sec.) and 290 rpm (7sec.)

Limit of Maximum Fan step

The maximum fan step is limited in the range shown in Figure based on the outside air temperature (TAOUT).

	TAOUT < 40°C	40°C ≤ TAOUT
Maximum Fan step	10	11

- The initial speed of the outdoor unit is detected by out door temperature sensor.

Outside air temperature sensor detected value	Fan step
TAOUT > 30°C	7
30°C ≥ TAOUT > 20°C	5
20°C ≥ TAOUT > 10°C	2
10°C ≥ TAOUT	0

Thereafter, the high-pressure is monitoring at a set time interval and the fan speed is changed by the following conditions.

(Conditions which lower the fan speed)
High-pressure saturation < low limit of target high-pressure saturation range and heat sink temperature ≤ 75°C

(Conditions which raise the fan speed)
High-pressure saturation > upper limit of target high-pressure saturation or heat sink temperature ≥ 80°C

The fan is controlled to keep high pressure saturation temperature within the target range as follows

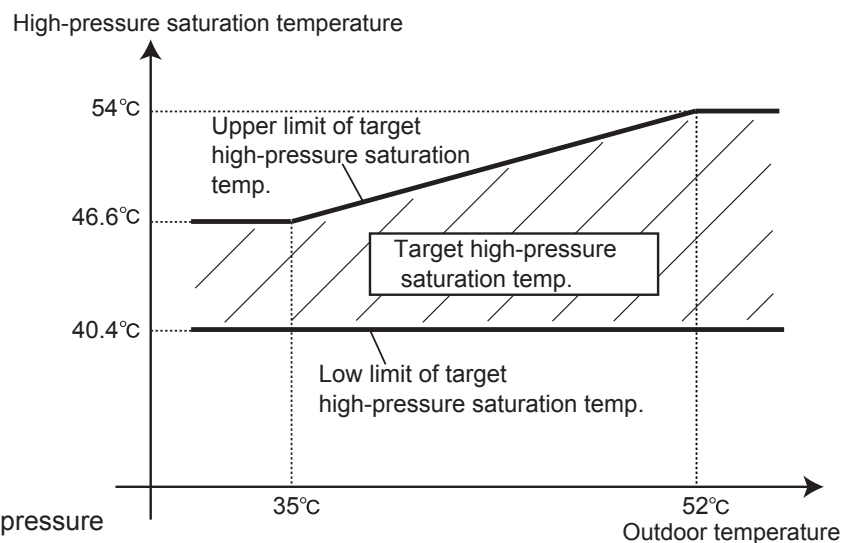

2-3-2 Heating Operation

Fan step	Fan speed (rpm)		
	AJ*040LCLAH	AJ*045LCLAH	AJ*054LCLAH
11	910	910	910
10	800	830	830
9	710	710	710
8	640	640	640
7	580	580	580
6	520	520	520
5	460	460	460
4	390	390	390
3	340	340	340
2	290	290	290
1	*intermittent	*intermittent	*intermittent
0	0	0	0

* intermittent operation : Repeat the cycle of 0 rpm (14sec.) and 290 rpm (7sec.)

Limit of Maximum Fan step

The maximum fan step is limited in the range shown in Figure based on the outside air temperature (TAOUT).

	TAOUT \leq 4°C	4°C < TAOUT
Maximum Fan step	11	10

● Switching conditions of step

The initial speed of the first boot outdoor unit is detected by outdoor air temperature sensor value (TAOUT).

Outside air temperature sensor detected value	Fan step
TAOUT < 10°C	Maximum Fan step
10°C \leq TAOUT < 15°C	8
15°C \leq TAOUT < 20°C	5
20°C \leq TAOUT	2

On heating mode, the fan operation is controlled as following based on the detection value of the Low-pressure sensor.

Low-pressure	
0.85MPa	Fan step : Down
0.75MPa	Fan step : Hold
	Fan step : Up

2-3-3 Low noise mode

When the low noise mode setting ON from PUSH SW or EXTERNAL INPUT, the outdoor unit operates in the low noise mode as follows.

«Settings and corresponding operations»

Capacity priority setting (PUSH SW)	Low noise level setting (PUSH SW)	Operation mode
OFF	ON	LOW NOISE MODE
ON	ON	* Automatic switching

«Low noise mode and operation contents»

		Level 1			Level 2		
		AJ*040L	AJ*045L	AJ*054L	AJ*040L	AJ*045L	AJ*054L
COOL	Max FAN Step	9	9	9	7	7	7
	FAN	710	710	710	580	580	580
	Max Compressor Speed	54	73	80	48	65	71
HEAT	Max FAN Step	9	9	9	7	7	7
	FAN	710	710	710	580	580	580
	Max Compressor Speed	59	78	80	54	71	73

The operating noise is reduced by limiting the rotational speed of the compressor and fan motor

LOW NOISE MODE . . . The operating sound lowers from about 3 to 5 dB more than the rated value

* Automatic switching

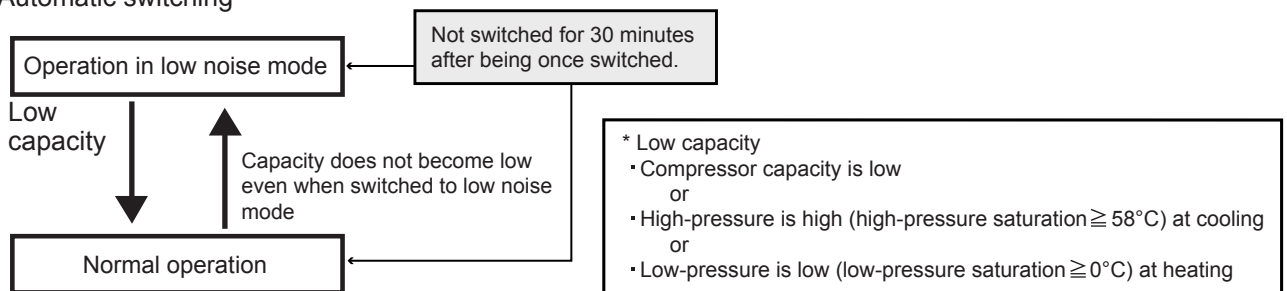

2-3-4 Other Control

To accurately detect the outside air temperature, the fan is operated while the outdoor unit is stopped.

2-4 EXPANSION VALVE CONTROL

	Initialization conditions	Operation mode	Control range	
			operation	stop
EEV	① When power turned on ② When operation stopped	Cooling	500 pulses	0 pulses
		Heating	12 - 500 pulses	

< Cooling mode >
500 pulses basically.

< Heating mode >
EEV is controlled so that the system reaches closer to the target discharge temperature that is calculated from high and low pressure.

2-5 SPECIAL OPERATION

2-5-1 Oil Recovery Operation

Purpose of the operation

The amount of refrigerant lubricant oil which has been transported to the indoor units and the connection pipe with the refrigerant will become large as the operation time of compressor increases. It is necessary to recover the oil back into the outdoor unit for a certain time interval in order to prevent compressors from damaging due to lack of lubrication oil.

1. Oil Recovery in Cooling operation

< Start condition >

Compressor accumulated operation time since last cooling oil recovery operation exceeds 3 hours.
(first time : 1hour)

< End condition >

30 seconds have elapsed since the start and
"suction temperature - low pressure saturation temperature $\leq 5\text{deg}$ " or 6 minutes have elapsed since the start.

< Operation >

COMPRESSOR : The rotation speed varies depending on the operation state.
EEV Opening (Indoor/Outdoor unit) : Controlled pulse (as normal operation mode).
FAN speed (Indoor/Outdoor unit) : Controlled fan speed (as normal operation mode).

2. Oil Recovery in Heating operation

< Start condition >

Compressor accumulated operation time since the last heating oil recovery exceeds 8 hours.
(first time : 1hour)

< End condition >

After 4 minutes have elapsed

< Operation >

COMPRESSOR : The rotation speed varies depending on the operation state.
EEV Opening (Indoor/Outdoor unit) : Controlled pulse (as normal operation mode)
FAN speed (Indoor/Outdoor unit) : Controlled fan speed (as normal operation mode)

Others

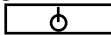
During the oil recovery operation,  appears on the display of wired and central remote controller, and  appears on the simple remote controller.
The operation indicators (LED) of the indoor units flash slowly.

2-5-2 Pre-heat Operation

This pre-heat operation protects the start up failure by preventing the refrigerant from soaking into the oil in compressor.
Crankcase heater ON: 30 minutes elapsed since installed compressors stopped (However, ON when power turned on)
OFF: Compressor starts

*It doesn't control according to the temperature.

2-5-3 Defrost Operation Control

Defrost Operation Start Condition 1

Outdoor temperature $< 2^{\circ}\text{C}$ and Compressor stop count exceed 20 times at less than 10 minutes of accumulated heating operation time

Defrost Operation Start Condition 2

Accumulated heating operation time is 40 minutes or longer

[Accumulated heating operation time is reset at the end of cooling operation or defrosting operation.]
and

an outdoor unit satisfies condition ① or ② below

Condition ①: "Heat exchange temperature $\leq -2^{\circ}\text{C}$ " accumulated operating time is *T1 minutes or longer

* Connection capacity $\leq 8.4\text{kW}$ -----> T1= 90 min.

Connection capacity $> 8.4\text{kW}$ -----> T1=180 min.

Condition ②: After the following all condition satisfied, "heat exchange temperature \leq defrosting start judgment temperature and during heat exchange liquid temperature drop" accumulated time:10minutes

(a) accumulated heating operation time ≥ 30 minutes

(b) 10 minutes have elapsed after outdoor unit starting

(c) 5 minutes have elapsed since oil recovery

⇒ * Defrosting start and end judgment temperature are determined by the outdoor temperature.

Defrosting start judgment temperature = $0.8 \times \text{outdoor temperature} - 11.6$ (However, -24°C to -6°C)

If the calculated result is lower than -24°C , the judgment temperature is defined as -24°C

If the calculated result is higher than -6°C , the judgment temperature is defined as -6°C

Defrost Operation End Condition

① At all outdoor units, heat exchange liquid temperature \geq end judgment temperature
or

② when 15 minutes have elapsed from the start

⇒ **Defrosting end judgment temperature = $0.39 \times \text{outdoor temperature} + 12.7$ (However, 5 to 12°C range)**

If the calculated result is lower than 5°C , the judgment temperature is defined as 5°C

If the calculated result is higher than 12°C , the judgment temperature is defined as 12°C

2-6 PROTECTIVE FUNCTION

2-6-1 Protective Function List

Protective Function	Detect Parts	COOL	HEAT	DISPLAY	Operating Condition	Operation
Discharge Temp Protection 1	Discharge Temp Thermistor	○		—	<p><Starting conditions> 3 minutes have elapsed since the start of operation and (discharge temperature $\geq 100^{\circ}\text{C}$ or suction SH $\geq 10^{\circ}\text{C}$ accumulated time 30 minutes)</p> <p><Reset conditions> Discharge temperature $\leq 95^{\circ}\text{C}$ and suctionSH $\leq 7^{\circ}\text{C}$</p>	EEV of operating indoor unit gradually opened
Discharge Temp Protection 4	Discharge Temp Thermistor	○	○	—	<p><Starting condition> Discharge temperature $\geq 105^{\circ}\text{C}$</p> <p><Reset condition> Discharge temperature $\leq 100^{\circ}\text{C}$</p>	Compressor speed -6rps every 30 secs Speed rise prohibited, when discharge temperature becomes lower than 105°C , prohibit the rotational speed rise of the compressor.
Discharge Temp Protection 5	Discharge Temp Thermistor		○	—	<p><Starting conditions> Discharge temperature $\geq 95^{\circ}\text{C}$ and EEV1=500pls</p> <p><Reset conditions> 2 minutes have elapsed and (discharge temperature $\leq 90^{\circ}\text{C}$ or EEV1 ≤ 400pls)</p>	Expansion valve of stopped indoor unit gradually opened (upper limit 200pls)
Discharge Temp Protection Stop	Discharge Temp Thermistor	○	○	P1	<p><Pattern ① starting condition> Discharge temperature \geq fixed value (115°C)</p> <p><Pattern ① reset condition> 3 minutes have elapsed and discharge temperature $\leq 80^{\circ}\text{C}$</p>	Compressor stopped
				EA11	<p><Pattern ② starting condition> Pattern ① generated 2 times within 40 minutes</p> <p><Pattern ② reset condition> Error reset (push button SW) executed after power turned on again</p>	Compressor stopped (permanent stop) Error display
High Pressure Protection 1	High Pressure Sensor	○		—	<p><Starting conditions> COMP < 25 rps ---- HP ≥ 3.46 MPa 25 rps \leq COMP ---- HP ≥ 3.80 MPa</p> <p><Reset conditions> Fixed time has elapsed and Fixed time when SV2: ON 30 secs COMP < 25 rps ---- HP ≤ 3.30 MPa 25 rps \leq COMP ---- HP ≤ 3.60 MPa</p>	SV2 ON
High Pressure Protection 2	High Pressure Sensor		○	—	<p><Starting conditions> COMP ≥ 25 rps ---- HP ≥ 3.80 MPa COMP < 25 rps ---- HP ≥ 3.46 MPa</p> <p><Reset conditions> 3 minutes have elapsed and high-pressure ≤ 2.80MPa</p>	SV2 ON
High Pressure Protection 3	High Pressure Sensor	○		—	<p><Starting conditions> Fixed time has elapsed and high-pressure ≥ 3.50MPa (* Fixed time at start of operation: 10 secs, after operation execution: 20 secs)</p> <p><Reset conditions> Operation (fan speed 1 step increase) complete</p>	Fan speed 1 step increase
High Pressure Protection 4	High Pressure Sensor		○	—	<p><Starting condition> High-pressure ≥ 3.50MPa</p> <p><Reset condition> High-pressure < 3.5MPa</p>	Fan lowest speed : 290 rpm
High Pressure Protection 5	High Pressure Sensor		○	—	<p><Starting conditions> High-pressure ≥ 3.20MPa</p> <p><Reset conditions> High-pressure < 3.20MPa</p>	Compressor capacity lowered/every 15 secs
Abnormal High Pressure Protection Control	High Pressure Sensor	○		—	<p><Pattern ① starting condition> COMP < 25 rps ---- HP ≥ 3.38 MPa COMP ≥ 25 rps ---- HP ≥ 3.68 MPa</p> <p><Pattern ① reset condition> After 25 seconds have elapsed and, COMP < 25 rps ---- HP < 3.3 MPa COMP ≥ 25 rps ---- HP < 3.6 MPa</p>	Compressor capacity rise prohibited
				—	<p><Pattern ② starting condition> COMP < 25 rps ---- HP ≥ 3.42 MPa COMP ≥ 25 rps ---- HP ≥ 3.76 MPa</p> <p><Pattern ② reset condition> After 25 seconds have elapsed and, COMP < 25 rps ---- HP < 3.38 MPa COMP ≥ 25 rps ---- HP < 3.68 MPa</p>	Compressor capacity lowered every 30 secs

Protective Function	Detect Parts	COOL	HEAT	DISPLAY	Operating Condition	Operation
High Pressure Protection Stop 1	High Pressure Sensor	○	○	P2	<Pattern ① starting condition> High-pressure $\geq 4.00\text{MPa}$ <Pattern ① reset condition> 5 minutes have elapsed and high-pressure $\leq 3.50\text{MPa}$	Compressor stopped
				EA41	<Pattern ② starting condition> Pattern ① generated 3 times within 60 minutes. <Pattern ② reset condition> 10 minutes have elapsed and high-pressure $\leq 3.50\text{MPa}$	Compressor stopped
Low Pressure Protection 1	Low Pressure Sensor	○		—	<Starting conditions> Low-pressure $\leq 0.20\text{MPa}$ <Reset conditions> 5 minutes have elapsed and low-pressure $\geq 0.30\text{MPa}$	SV2 ON
Low Pressure Protection 2	Low Pressure Sensor		○	—	<Starting conditions> Low-pressure $\leq 0.10\text{MPa}$ <Reset conditions> 3 minutes have elapsed and low-pressure $\geq 0.17\text{MPa}$	SV2 ON
Low Pressure Protection 4	Low Pressure Sensor		○	—	<Starting conditions> 3 minutes have elapsed and low-pressure $\leq 0.18\text{MPa}$ <Reset conditions> 3 minutes have elapsed and low-pressure $\geq 0.22\text{MPa}$	EEV of stopped indoor unit opened quickly (450pls)
Abnormal Low Pressure Protection Control	Low Pressure Sensor		○	—	<Starting condition> Low-pressure $\leq 0.16\text{MPa}$ <Reset condition> 3 minutes have elapsed and low-pressure $\geq 0.18\text{MPa}$	Compressor capacity lowered every 180 secs, when the Low-pressure becomes more than 0.17MPa, prohibit compressor capacity rise.
Low Pressure Protection Stop	Low Pressure Sensor	○	○	P3	<Pattern ① starting condition> Low-pressure $\leq 0.05\text{MPa}$ or low-pressure $\leq 0.10\text{MPa}$ continues for 10 mins <Pattern ① reset condition> 3 minutes have elapsed and low-pressure $\geq 0.17\text{MPa}$	Compressor stopped
				EA51	<Pattern ② starting condition> Pattern ① generated 5 times within 180 minutes. <Pattern ② reset condition> Error reset (push button SW) executed after power turned on again.	Compressor stopped (permanent stop) Error display
Compressor Temp Protection Stop	Compressor Temp Thermistor	○	○	P4	<Pattern ① starting condition> Compressor temperature \geq fixed value (110°C) <Pattern ① reset condition> 3 minutes have elapsed and discharge temperature $\leq 80^\circ\text{C}$	Compressor stopped
				EA31	<Pattern ② starting condition> Pattern ① generated 2 times within 40 minutes <Pattern ② reset condition> Error reset (push button SW) executed after power turned on again	Compressor stopped (permanent stop) Error display

Protective Function	Detect Parts	COOL	HEAT	DISPLAY	Operating Condition	Operation
Overcurrent Break Stop (Compressor)	Overcurrent Protection Circuit	○	○	E941 (permanent stop)	Compressor is stopped when the over current protection circuit in the inverter PCB detects an abnormal current during the operation. If it repeated 5 times, the compressor becomes permanent stop.	Compressor stopped
				E931 (permanent stop)	Compressor is stopped when the over current protection circuit in the inverter PC Board detects an abnormal current at the time of start up. Compressor becomes permanent stop if it repeated over the number of set time.	
				—	<Reset condition> Error reset (push button SW) executed after power turned on again.	
Heatsink Temp Protection Stop	Heatsink Temp Thermistor	○	○	—	<Pattern ① starting condition> Heat sink temperature $\geq 100^{\circ}\text{C}$ <Pattern ① reset condition> 3 minutes have elapsed and heat sink temperature $\leq 85^{\circ}\text{C}$	Compressor stopped
				EAC4	<Pattern ② starting condition> Pattern ① generated 3 times within 60 minutes. <Pattern ② reset condition> 10 minutes have elapsed and heat sink temperature $\leq 85^{\circ}\text{C}$	Compressor stopped Error display
Frequency Maximum Setting Protection (Compressor)	Current Detector Circuit	○	○	—	[AJQ112/ 140] <Pattern ① starting condition> Current value \geq Cooling: 23.5A / Heating: 23.5A <Pattern ① reset condition> Current value $<$ Cooling: 23.5A / Heating: 23.5A [AJQ155] <Pattern ① starting condition> Current value \geq Cooling: 25.5A / Heating: 25.5A <Pattern ① reset condition> Current value $<$ Cooling: 25.5A / Heating: 25.5A	Compressor speed rise prohibited
				—	[AJQ112/ 140] <Pattern ② starting condition> Current value \geq Cooling: 24.0A / Heating: 24.0A <Pattern ② reset condition> Current value $<$ Cooling: 24.0A / Heating: 24.0A [AJQ155] <Pattern ② starting condition> Current value \geq Cooling: 26.0A / Heating: 26.0A <Pattern ② reset condition> Current value $<$ Cooling: 26.0A / Heating: 26.0A • Pattern ① and ② start current value changed by outside temperature	Compressor speed lowered



AIRSTAGE™ J-IIS

Variable Refrigerant Flow System

3. INDOOR UNIT OPERATION

3. INDOOR UNIT OPERATION

3-1 FAN CONTROL

3-1-1 Fan Speed Setting

Fan speed setting



Press the FAN CONTROL button to set the fan speed.



3-1-2 "AUTO" Position

1. COOLING OPERATION

The fan speed is determined automatically in accordance with the condition " T_R (corrected room temperature) - T_s (corrected set temperature)" as shown on the right. However, the fan speed zone is determined in the manner as the room temperature increases for the following cases.

- (1) When the T_s is changed.
- (2) When the operation mode is changed from other mode to "COOL".
- (3) When the fan control is changed from other position to "AUTO".

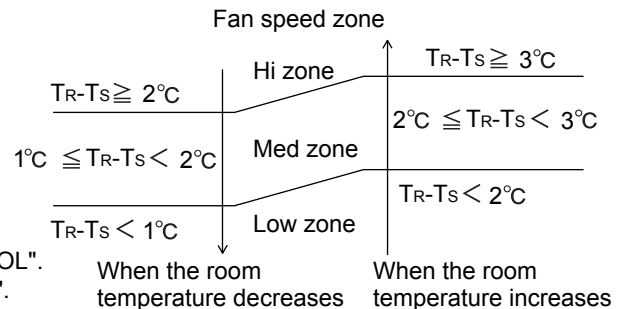

2. HEAT OPERATION

Same as Cooling operation, fan speed is decided by the difference between the room temperature and the set temperature.

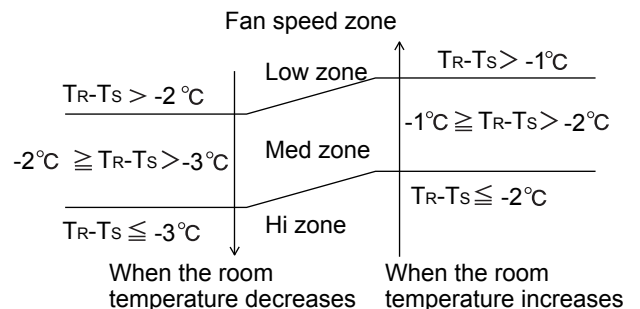

3. DRY OPERATION

The indoor fan always rotates at "Lo" speed.

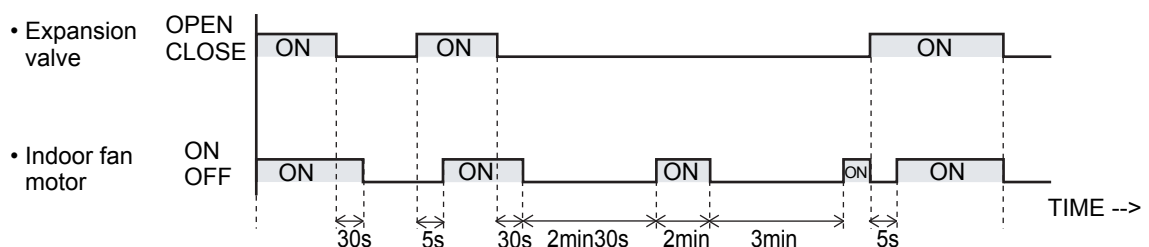

- (1) The indoor fan starts operation 5 seconds after the electric expansion valve opens. However, when the indoor unit just starts its operation or the operation mode is changed from other to "DRY" and the refrigerant circulation is not stopped, the fan will rotate immediately without a delay time of 5 seconds.
- (2) The indoor fan will stop in 30 seconds when the refrigerant circulation stops.
- (3) The indoor fan will stop immediately when the indoor unit is stopped by pushing the stop button or by a setting of ON timer.
- (4) When the refrigerant circulation is stopped due to a lower room temperature for more than 3 minutes, the fan will rotate 2 minutes at intervals of 3 minutes.
- (5) When the indoor unit just starts its operation or the operation mode is changed from other to "DRY" and the refrigerant circulation is stopped, the fan will rotate for 1 minute and then it will operate according to the statement (4).

3-2 MASTER CONTROL

3-2-1 Operation Mode Control

Each operation mode is controlled as below.

(1) Stop mode

- Indoor fan motor : OFF
- Electric expansion valve : Stop pulse
- Drain pump : Turns ON-OFF by the drain pump control function

(2) Cool, Dry and Heat Mode

	Cool	Dry	Heat
Indoor fan motor	Operates according to the AIR FLOW-MODE setting.	See the fan control page.	Operates according to the AIR FLOW-MODE setting, and besides cold air prevention operation
Drain pump	Turns ON-OFF by the drain pump control function		
Electrical expansion valve	Pulse controlled by the temperature difference calculation and frost prevent function	Pulse controlled by the temperature difference calculation and frost prevent function	Pulse controlled by the temperature difference.

(3) Priority mode

The purpose of the priority mode is to restrict operation commands (heating, cooling, dry) from the connected indoor units. There are 3 priority modes of Neutral, Cooling Priority, and Heating Priority. The operation modes restricted by each of these modes are as follows:

Priority mode	Restricted operation mode
Neutral	No restrictions
Cooling priority	Heating
Heating priority	Cooling, dry

1. Priority mode decision methods

Method 1. (Default value)

The initial priority mode is made Neutral and is shifted to Cooling Priority when cooling and to Heating Priority when heating depending on which operation mode (cooling, heating) was input first. After shifting to Cooling Priority or Heating Priority, the priority mode shifts to Neutral only when there was a Stop input from all the indoor units.

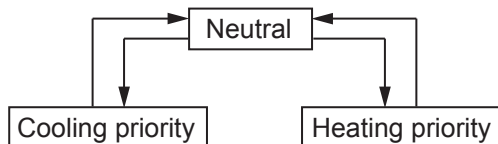

Method 2. (Management by outdoor unit)

Operation mode management is made "Management by outdoor unit" by outdoor unit PUSH-SW (field setting).

The priority mode shifts to Cooling Priority or Heating Priority in accordance with input from the outdoor unit regardless of the current mode.

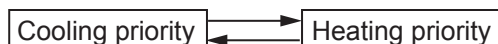

Method 3. (Management by indoor unit)

Operation mode management is made "Management by indoor unit" by outdoor unit PUSH-SW (field setting).

Then the master indoor unit is set by wired remote controller.

Thereupon the priority mode shifts to Cooling Priority or Heating Priority in accordance with input from the master indoor unit regardless of the current priority mode.

The priority mode is fixed at either cooling or heating even if the master indoor unit stops

Cooling/heating switching can be performed by the master indoor unit only.

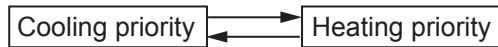

(4) Opposite operation mode

When the operation mode commanded from an indoor unit (remote controller) and the operation mode allowed by the system (cooling and dry operation for cooling only type and operation mode allowed by priority mode for heat pump type) do not match, it is indicated by blinking of an LED.

Timer lamp: 3 secs ON/1 sec OFF repeated

3-2-1 Operation Mode Control for Outdoor air unit

Each operation mode is controlled as below.

(1) Stop mode

- Outdoor air unit fan motor : OFF
- Electric expansion valve : Stop pulse
- Drain pump : Turns ON-OFF by the drain pump control function
- Solenoid valve : Closed

(2) Cool and Heat Mode

Each operation mode is controlled as below.

	Cool	Heat	Fan
Outdoor air unit fan motor	Operates according to the HIGH MODE setting.	Operates according to the HIGH MODE setting.	Operates according to the HIGH MODE setting.
Drain pump	Turns ON-OFF by the drain pump control function		
Electrical expansion valve	Pulse controlled by the temperature difference calculation and freeze prevention control	Pulse controlled by the temperature difference.	Stop pulse
Solenoid valve	Closed at all times	Opened at thermostat off and compressor on. Closed at other operation.	Closed at all times

(3) Priority mode

The purpose of the priority mode is to restrict operation commands (heating, cooling) from the connected outdoor air units. There are 3 priority modes of Neutral, Cooling Priority, and Heating Priority. The operation modes restricted by each of these modes are as follows:

Priority mode	Restricted operation mode
Neutral	No restrictions
Cooling priority	Heating
Heating priority	Cooling

1. Priority mode decision methods

Method 1. (Default value)

The initial priority mode is made Neutral and is shifted to Cooling Priority when cooling and to Heating Priority when heating depending on which operation mode (cooling, heating) was input first. After shifting to Cooling Priority or Heating Priority, the priority mode shifts to Neutral only when there was a Stop input from all the indoor units.

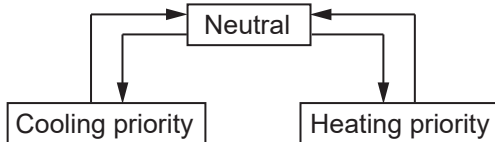

Method 2. (Management by Outdoor unit)

Operation mode management is made "Management by Outdoor unit" by Outdoor unit PUSH-SW (field setting).

The priority mode shifts to Cooling Priority or Heating Priority in accordance with input from the Outdoor unit regardless of the current mode.

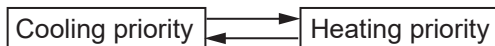

Method 3. (Management by indoor unit)

Operation mode management is made "Management by indoor unit" by Outdoor unit PUSH-SW (field setting).

Then the master indoor unit is set by wired remote controller.

Thereupon the priority mode shifts to Cooling Priority or Heating Priority in accordance with input from the master indoor unit regardless of the current priority mode.

The priority mode is fixed at either cooling or heating even if the master indoor unit stops. Cooling/Heating switching can be performed by the master indoor unit only.

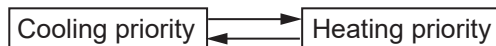

(4) Opposite operation mode

When the operation mode commanded from an indoor unit (remote controller) and the operation mode allowed by the system (cooling and dry operation for cooling only type and operation mode allowed by priority mode for heat pump type) do not match, it is indicated by blinking of an LED.

Timer lamp: 3 secs ON/1 sec OFF repeated

3-2-2 Auto Changeover

[Method]

1. Switch operation mode management to "Management by indoor unit" by outdoor unit DIP-SW.
2. Set the master indoor unit by wired remote controller.
3. Judge cooling/heating by the difference between the master indoor unit's setting temperature and the room temperature.

■ AUTO CHANGEOVER operation

Operation flow chart

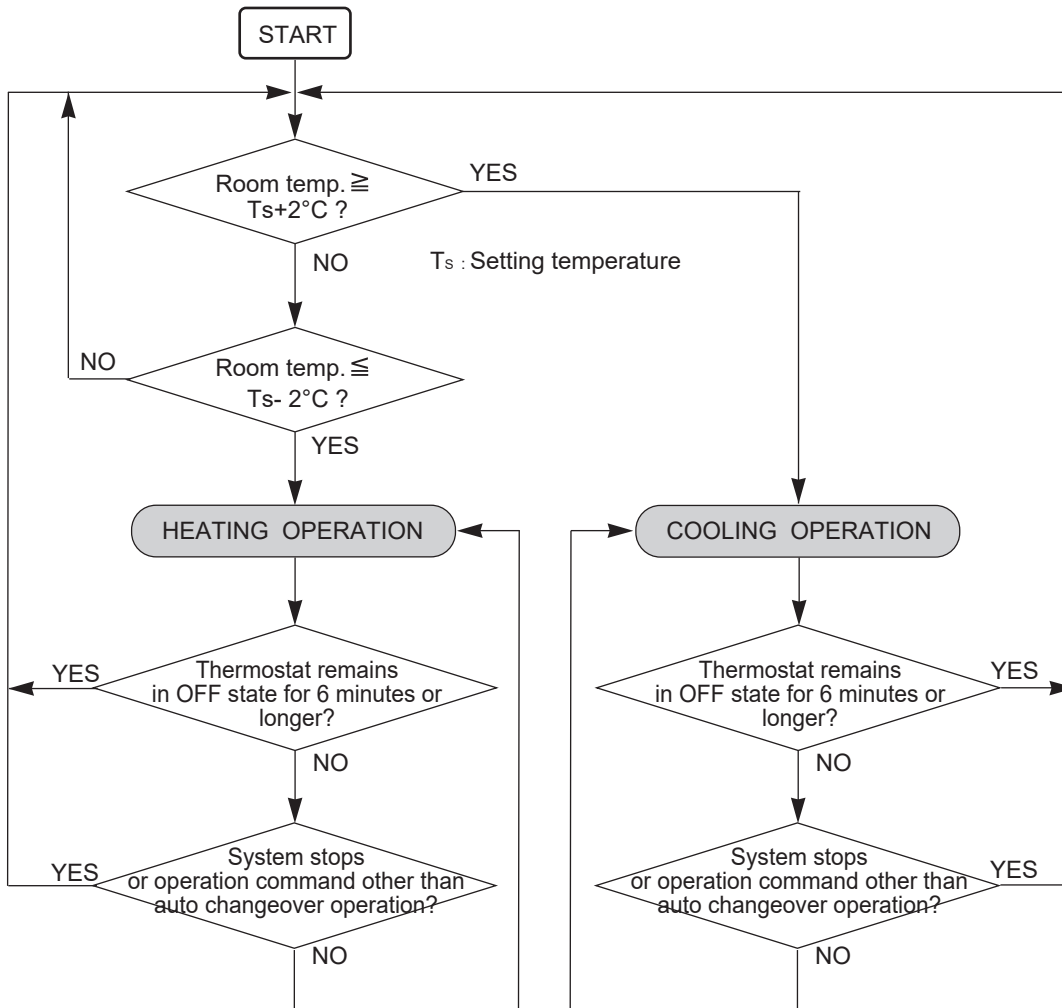

3-2-2 Auto Changeover Heating / Cooling Operation for Outdoor air unit

Function is available when an outdoor air unit set as the administrative indoor unit (Management Outdoor air unit).
Refer to the setting Method

Setting Method

1. Switch operation mode management to "Management by outdoor air unit" by Outdoor unit PUSH-SW.
2. Set the master outdoor air unit by wired remote controller.
3. Judge cooling/heating by the difference between the master outdoor air unit's setting temperature and the suction airflow temperature

■ AUTO CHANGEOVER operation

Operation flow chart

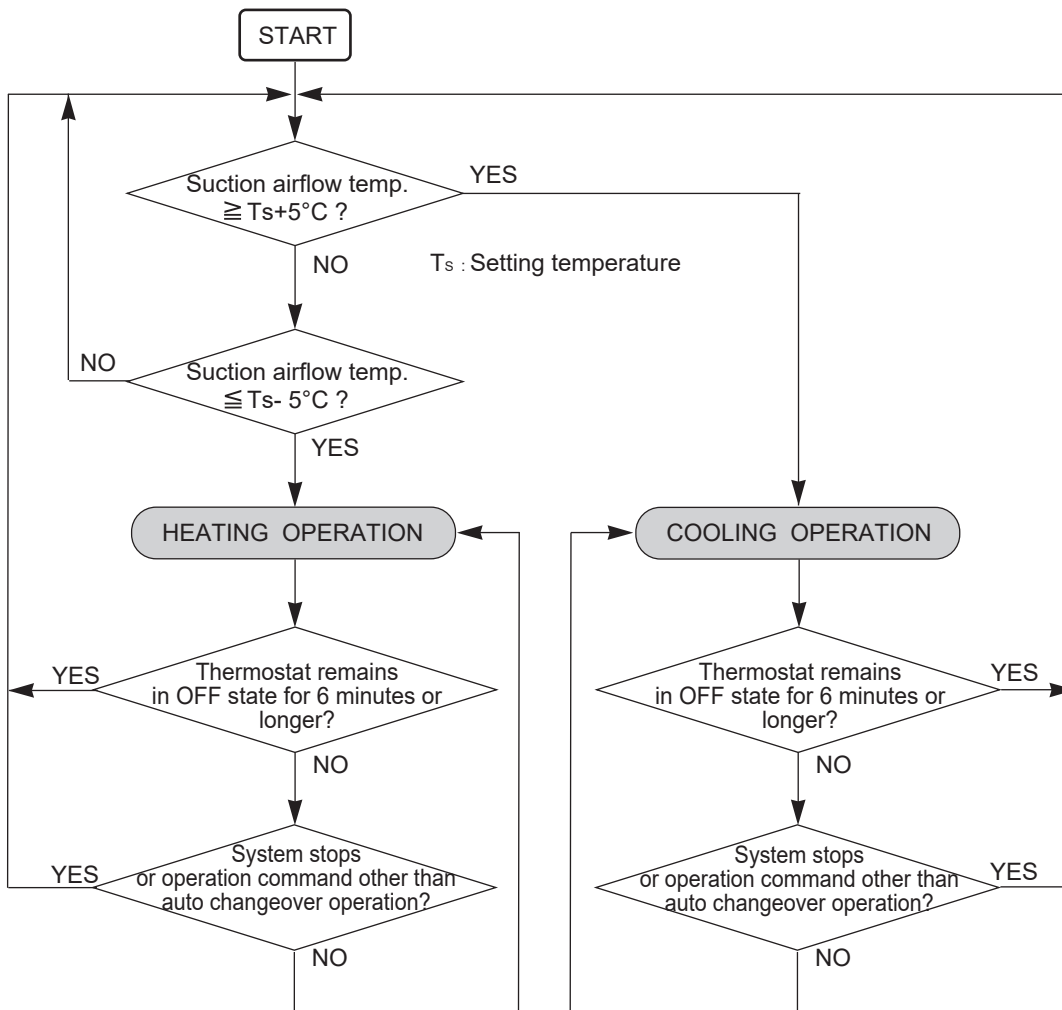

3-2-3 "COOL" Position

When using the cooling mode, set the temperature to a value lower than the current room temperature, otherwise the indoor unit will not start the cooling operation and only the fan will rotate.

An example for COOLING TEMPERATURE CONTROL time chart (Manual setting)

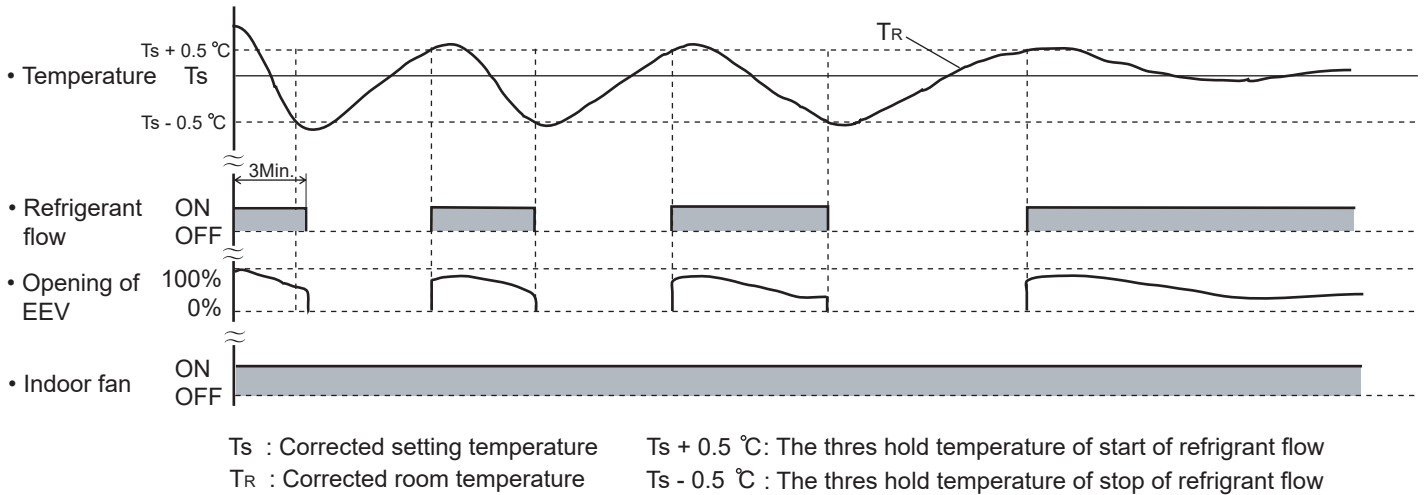

3-2-4 "HEAT" Position

- (1) When using the heating mode, set the temperature to a value higher than the current room temperature, otherwise the indoor unit will not start the heating operation.
- (2) After the start of heating operation, the fan of indoor unit will not rotate until the heater exchange is warmed up to blow out warm air.
- (3) During defrosting, the OPERATION indicator lamp flashes 6 sec. ON and 2 sec. OFF, and repeat. The heating operation will be temporarily interrupted.

An example for HEATING TEMPERATURE CONTROL time chart (Manual setting)

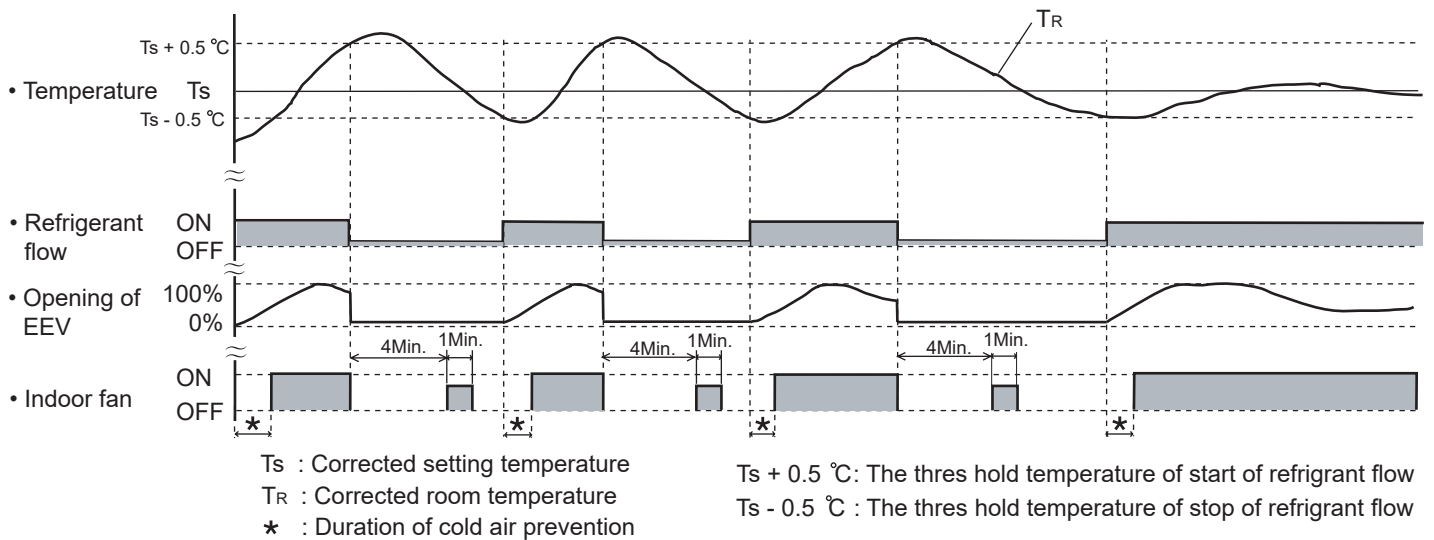

3-2-3 "COOL" Position for Outdoor air unit

When using the cooling mode, set the temperature to a value lower than the discharge airflow temperature, otherwise the outdoor air unit will not start the cooling operation and only the fan will rotate.

An example for COOLING TEMPERATURE CONTROL time chart (Manual setting)

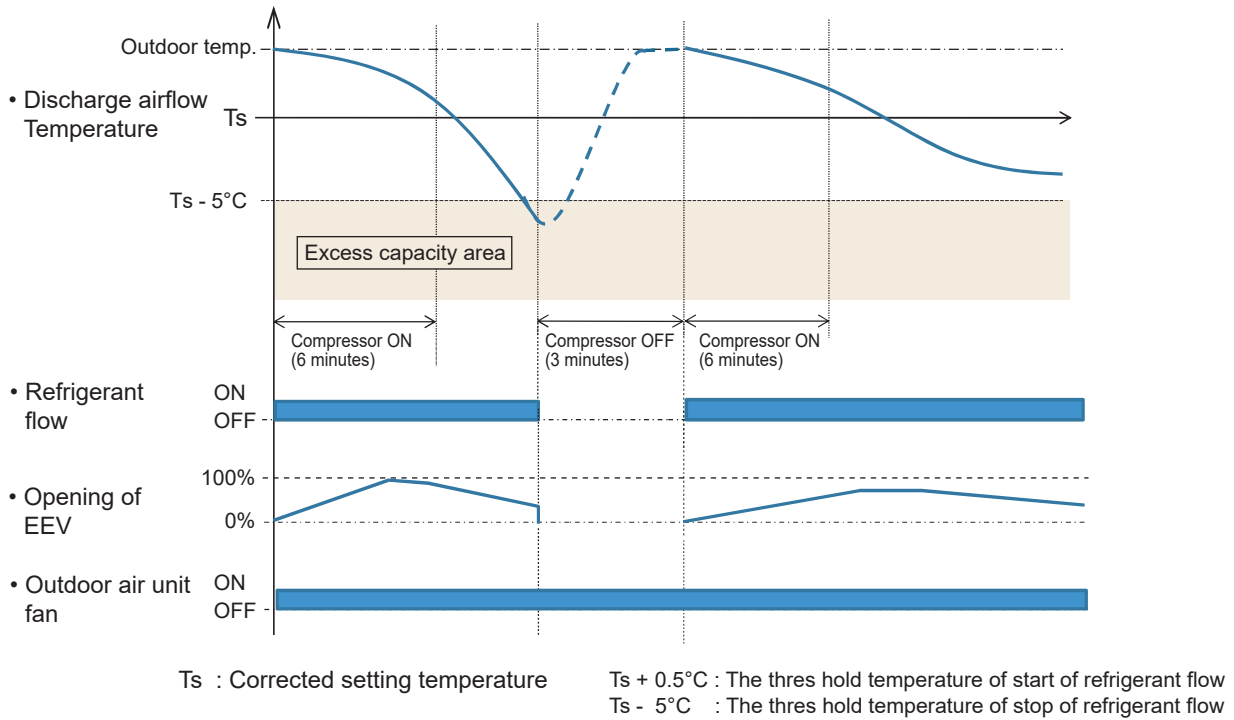

3-2-4 "HEAT" Position for Outdoor air unit

- (1) When using the heating mode, set the temperature to a value higher than the discharge airflow temperature, otherwise the outdoor air unit will not start the heating operation.
- (2) During defrosting, the OPERATION indicator lamp flashes 6 sec. ON and 2 sec. OFF, and repeat. The heating operation will be temporarily interrupted.

An example for HEATING TEMPERATURE CONTROL time chart (Manual setting)

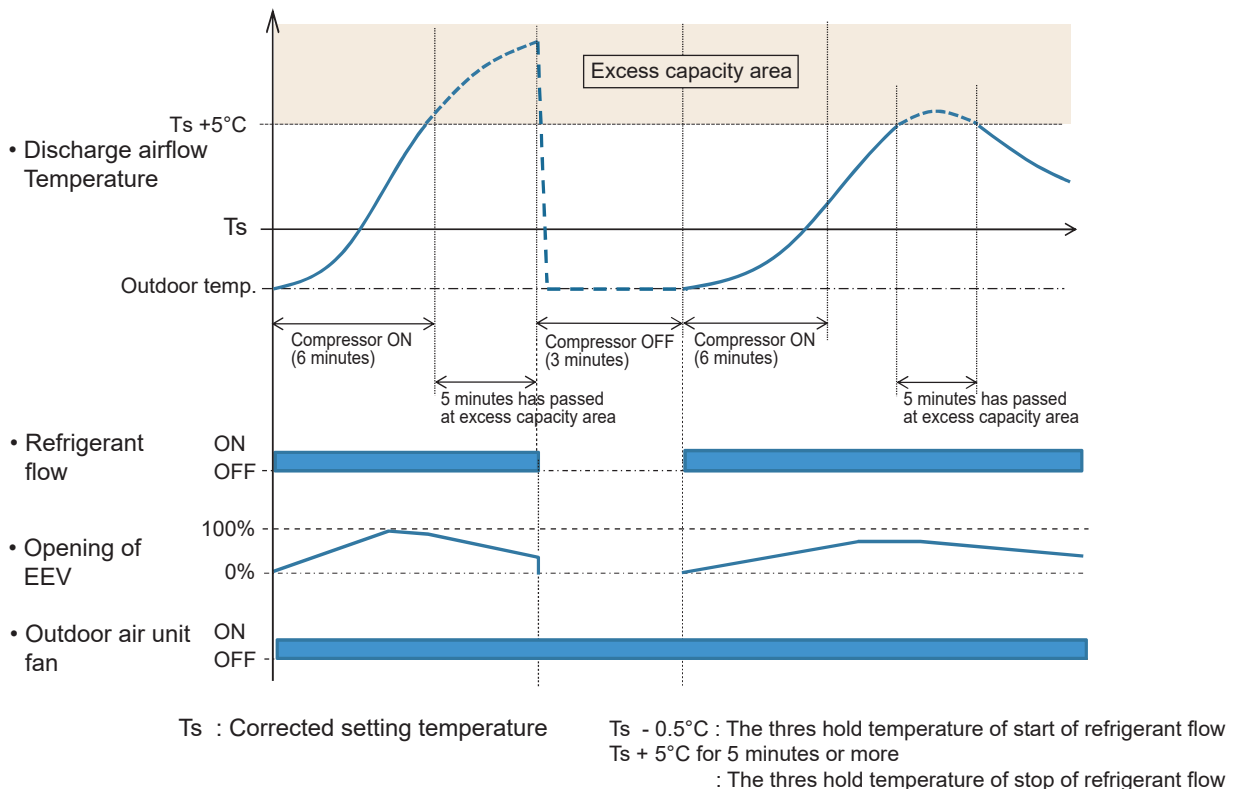

3-3 LOUVER CONTROL

(1) ADJUSTING THE DIRECTION OF AIR CIRCULATION

Instructions relating to heating (*) are applicable only to heat pump type outdoor unit.
Begin air conditioner operation before performing this procedure.

Vertical Air Direction Adjustment

This instructions are applicable to "LARGE CEILING TYPE", "UNIVERSAL FLOOR/CEILING TYPE", "CASSETTE TYPE", "WALL MOUNTED TYPE", "COMPACT WALL MOUNTED TYPE" and "COMPACT FLOOR TYPE".

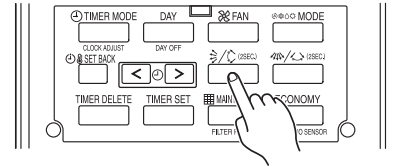

Press the **VERTICAL AIR FLOW DIRECTION SET** button.

Example : When set to vertical air direction.

- Press the VERTICAL AIRFLOW DIRECTION button.
The temperature display will change to the vertical airflow direction setting display.
- Press the VERTICAL AIRFLOW DIRECTION button to change the vertical louvre position.
The position number will appear on the display.

Cooling & Dry : ①, ②, ③, ④

Heating : ①, ②, ③, ④

■ LARGE CEILING TYPE

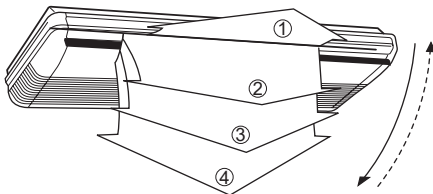

■ UNIVERSAL FLOOR/CEILING TYPE

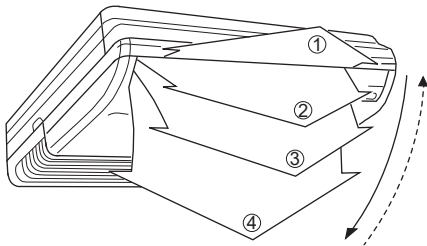

■ CASSETTE TYPE

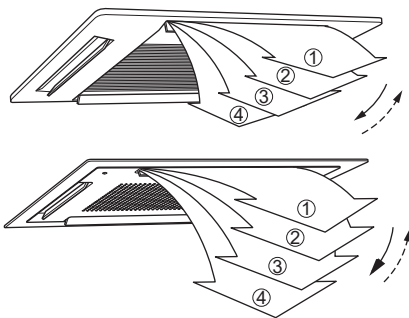

■ WALL MOUNTED TYPE

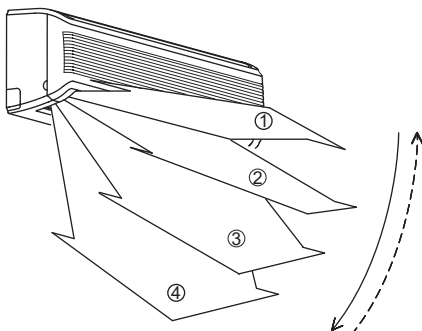

■ COMPACT WALL MOUNTED TYPE

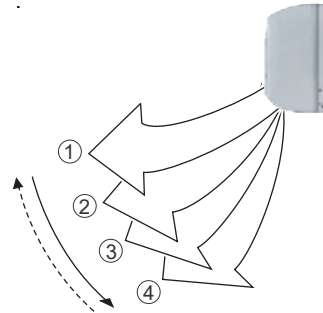

■ COMPACT FLOOR TYPE

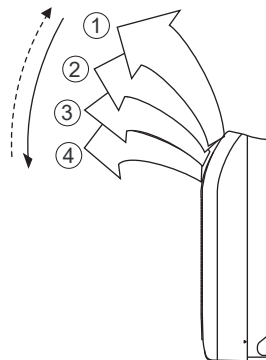

⚠ DANGER!

Never place fingers or foreign objects inside the outlet ports, since the internal fan operates at high speed and could cause personal injury.

- Always use the remote control unit's AIR FLOW DIRECTION button to adjust the UP/DOWN air direction flaps or RIGHT/LEFT air direction louvers. At tempting to move them manually could result in improper operation; in this case, stop operation and restart. The louvers should begin to operate properly again.
- When used in a room with infants, children, elderly or sick persons, the air direction and room temperature should be considered carefully when making settings.

- Use the air direction adjustments within the ranges shown above.
- The vertical airflow direction is set automatically as shown, in accordance with the type of operation selected.
 - During Cooling mode : Horizontal flow ①
 - * During Heating mode : Downward flow ④
- During AUTO mode operation, for the first minute after beginning operation, airflow will be horizontal ①, the air direction cannot be adjusted during this period.

Horizontal Air Direction Adjustment

This instructions are applicable to "LARGE CEILING TYPE", "UNIVERSAL FLOOR/CEILING TYPE" and "WALL MOUNTED TYPE".

Press the **HORIZONTAL AIR FLOW DIRECTION SET** button.

- Press the HORIZONTAL AIRFLOW DIRECTION button. The temperature display will change to the horizontal airflow direction setting display.
- Press the HORIZONTAL AIRFLOW DIRECTION button to change the horizontal louvre position. The position number will appear on the display.

Cooling & Dry : ①, ②, ③, ④, ⑤

Heating : ①, ②, ③, ④, ⑤

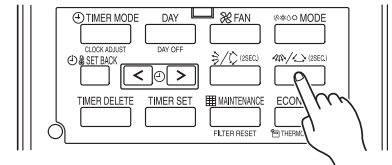

Example : When set to horizontal air direction.

■ LARGE CEILING TYPE

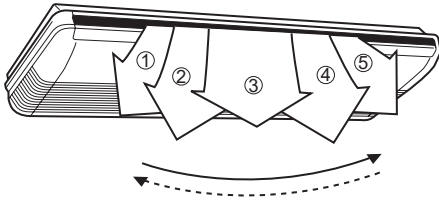

■ WALL MOUNTED TYPE

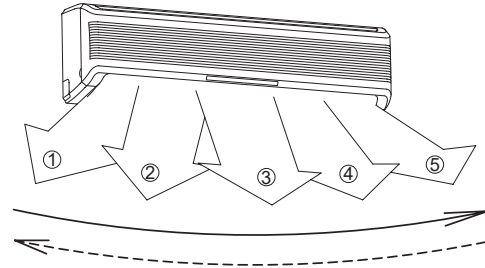

■ UNIVERSAL FLOOR/CEILING TYPE

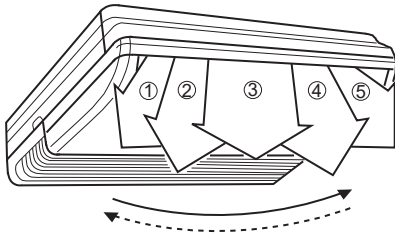

(2) SWING OPERATION

Instructions are applicable to "LARGE CEILING TYPE", "UNIVERSAL FLOOR / CEILING TYPE", "CASSETTE TYPE", "WALL MOUNTED TYPE", "COMPACT WALL MOUNTED TYPE" and "COMPACT FLOOR TYPE".

Begin air conditioner operation before performing this procedure.

To select Vertical airflow SWING Operation

This instructions are applicable to "LARGE CEILING TYPE", "UNIVERSAL FLOOR/CEILING TYPE", "CASSETTE TYPE", "WALL MOUNTED TYPE", "COMPACT WALL MOUNTED TYPE" and "COMPACT FLOOR TYPE".

Press the **VERTICAL SWING** button for more than two seconds.

The remote controller's Vertical Swing Display will light up.
In this mode, the UP/DOWN air direction flaps will swing automatically to direct the air flow both up and down.

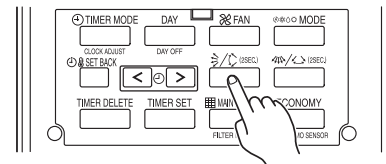

Example : When set to vertical swing.

To Stop Vertical airflow SWING Operation

Press the **VERTICAL SWING** button for more than two seconds once and again.

The remote controller's Vertical Swing Display will go out.
Airflow direction will return to the setting before swing was begun.

Instructions are applicable to "LARGE CEILING TYPE", "UNIVERSAL FLOOR / CEILING TYPE", "CASSETTE TYPE", "WALL MOUNTED TYPE", "COMPACT WALL MOUNTED TYPE", and "COMPACT FLOOR TYPE".

About Vertical Airflow SWING Operation

- The SWING operation may stop temporarily when the air conditioner's fan is not operating, or when operating at very low speeds.
- The swing operation is not available depending on the model. Please refer to the operating manual for the indoor unit.

Air swing range

Air flow direction set	Range of swing
①	① to ④ (All range)
②	
③	
④	

To select Horizontal Airflow SWING Operation

This instructions are applicable to "LARGE CEILING TYPE", "UNIVERSAL FLOOR / CEILING TYPE", "WALL MOUNTED TYPE".

Press the HORIZONTAL SWING button for more than two seconds.

The remote controller's Horizontal Swing Display will light up. In this mode, the RIGHT/LEFT air direction louvers will swing automatically to direct the airflow both right and left.

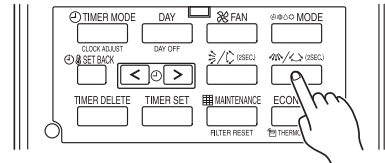

Example : When set to horizontal swing.

To stop Horizontal airflow SWING Operation

Press the HORIZONTAL SWING button for more than two seconds once and again.

The remote controller's Horizontal Swing Display will go out. Airflow direction will return to the setting before swing was begun.

About Horizontal Airflow Swing Operation

- Left and right swing range can be changed in 3 steps by field setting.
- The SWING operation may stop temporarily when the air conditioner's fan is not operating, or when operating at very low speeds.
- The swing operation is not available depending on the model. Please refer to the operating manual for the indoor unit.

Left and right swing range (◆ ... Factory setting)

Range of swing	Function Number	Setting Value
◆ ① to ⑤ (All range)	24	00
① to ③		01
③ to ⑤		02

3-4 ELECTRONIC EXPANSION VALVE CONTROL

1. Initialization

- When the power is turned ON.
- When it has passed the limited time since the last initialization.

2. Operation Control

- When indoor unit stopping

Outdoor unit Condition	EEV Condition
OFF	Fully closed
Cooling	Fully closed
Heating	Slightly open

- When starting up
(Cooling) Move to the cooling control base pulse in steps.
(Heating) Move to the heating control base pulse in steps.
- Automatic operatic control
Automatic PI control is performed based on the indoor unit heat exchanger outlet temp and inlet temp.
- Room temperature control
The room temperature is controlled so that it reaches to the set-up temperature based on the difference between the room temperature and the set-up temperature, and the change of indoor unit temperature. if the room temperature becomes 0.5°C lower than the set-up temperature, EEV is fully closed.

3. Special Control

- Oil recovery operation : Controlled pulse.
- Test run operation : Controlled pulse.
- Icing protection control : Fully closed.
- Pump down operation : Fully open.
- Defrost operation : Controlled pulse

3-5 DRAIN PUMP OPERATION

- (1) When cooling and refrigerant circulation starts, the drain pump starts simultaneously.
- (2) The drain pump operates continuously for 3 minutes after the refrigerant circulation stopped.
- (3) When the refrigent circulation is stopped by a start of indoor heat exchanger frost prevention operation, the drain pump will turn off in 1 hour after the end of indoor heat exchanger frost prevention operation.
- (4) When the water level in the drain pan rises up and then the float switch functions:
 - ① Microcomputer stops the refrigerant circulation and indoor fan motor operation.
 - ② Drain pump operates continuously for 3 minutes after the float switch is turned off.
(Almost condensing water may be drained)
- (5) When the float switch turns ON continuously for 3 minutes, 'FAILURE INDICATION' operates.
- (6) When the float switch turns OFF within 3 minutes, the unit starts cooling operation.

3-4 ELECTRONIC EXPANSION VALVE CONTROL for Outdoor air unit

1. Initialization

- When the power is turned ON.
- When it has passed the limited time since the last initialization.

2. Operation Control

- When indoor unit stopping by Thermo-OFF condition.

Outdoor unit Condition	EEV Condition
OFF	Fully closed
Cooling	Fully closed
Heating	Fully closed

- When starting up
(Cooling) Move to the cooling control base pulse in steps.
(Heating) Move to the heating control base pulse in steps.
- Automatic operatic control
Automatic PI control is performed based on the indoor unit heat exchanger outlet temp and inlet temp.
- Discharge airflow temperature control
The discharge airflow temperature is controlled so that it reaches to the set-up temperature based on the difference between the discharge airflow temperature and the set-up temperature.
Cooling operation: 1) If the discharge airflow temperature becomes 5°C lower than the set-up temperature, EEV is fully closed.
2) If the suction airflow temperature becomes 0.5°C lower than the set-up temperature, EEV is fully closed.
Heating operation: 1) If the discharge airflow temperature becomes 5°C higher than the set-up temperature for 5 minutes or more, EEV is fully closed.
2) If the suction airflow temperature becomes 0.5°C higher than the set-up temperature, EEV is fully closed.

3. Special Control

- Oil recovery operation : Controlled pulse(Maximum 1400 puls)
- Test run operation : Controlled pulse.
- Freeze prevention control : Fully closed.
- Vacuuming operation : Fully open.
- Defrost operation : Controlled pulse(Maximum 1400 puls)

3-5 DRAIN PUMP OPERATION for Outdoor air unit

- (1) When cooling and refrigerant circulation starts, the drain pump starts simultaneously.
- (2) The drain pump operates continuously for 3 minutes after the refrigerant circulation stopped.
- (3) When the refrigent circulation is stopped by a start of indoor heat exchanger frost prevention operation, the drain pump will turn off in 1 hour after the end of indoor heat exchanger frost prevention operation.
- (4) When the water level in the drain pan rises up and then the float switch functions:
 - ① Microcomputer stops the refrigerant circulation and indoor fan motor operation.
 - ② Drain pump operates continuously for 3 minutes after the float switch is turned off.
(Almost condensing water may be drained)
- (5) When the float switch turns ON continuously for 3 minutes, 'FAILURE INDICATION' operates.
- (6) When the float switch turns OFF within 3 minutes, the unit starts cooling operation.

3-6 FUNCTION

3-6-1 Auto Restart

The air conditioner restarts with the previous setting operation.

3-6-2 Icing Protection Control

The icing of the indoor heat exchanger is prevented during the cooling and dry mode operation.

(1) Starting Condition

- Compressor is operation more than 3 minutes.
When "Heat exchanger inlet temperature $\leq T_A$ " continues *4 minutes or more.
- Compressor is operation more than 3 minutes.
When "Heat exchanger outlet temperature $\leq T_A$ " continues 4 minutes or more.

(2) Operation

EEV is closed.
Fan is at the setting amount.

(3) Completing Condition

Heat exchanger inlet and middle temperature $\geq T_B$
After more than 5 minutes

* Drain pump turns off at 60 minutes past the completion of the icing protection operation.

T_A	T_B
1°C	7°C

3-6-3 Oil Recovery Operation

[Oil recovery operation] : It periodically returns the residual refrigerant ion oil in the indoor unit and the connection piping back to the outdoor unit , and prevents the compressor oil level from decreasing.

Indoor unit LED : Operation LED

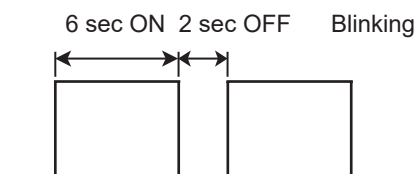

Indoor fan : Same operation before oil recovery operation.

Indoor EEV : Control pulse

* During the above operation, a refrigerant noise may be from the indoor unit.

3-6-4 Outdoor temperature protected operation for Outdoor air unit

1. COOL OPERATION

The contents of operation is controlled as following based on the suction airflow temperature.

- a) Operation mode management is made "Management by indoor unit", and outdoor air unit is master indoor unit.

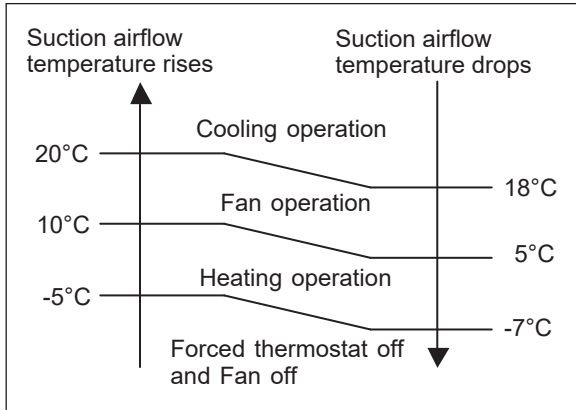

- b) Cases Other than (a)

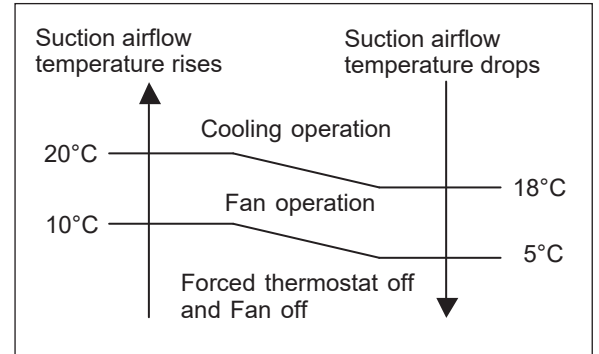

2. HEAT OPERATION

The contents of operation is controlled as following based on the suction airflow temperature.

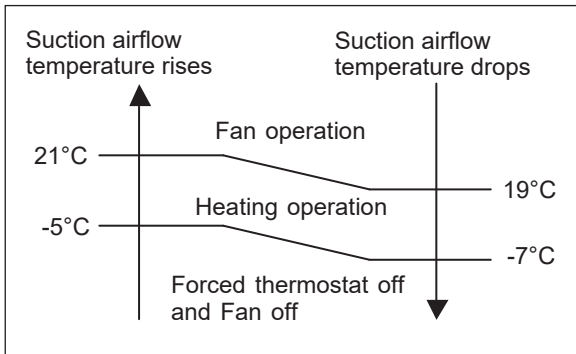

3. FAN OPERATION

The contents of operation is controlled as following based on the suction airflow temperature.

- a) Operation mode management is made "Management by indoor unit", and outdoor air unit is master indoor unit.

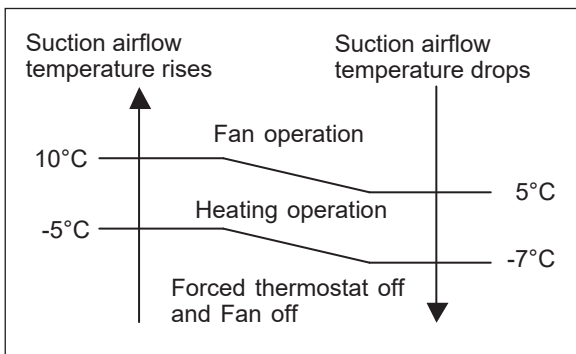

- b) Cases Other than (a)

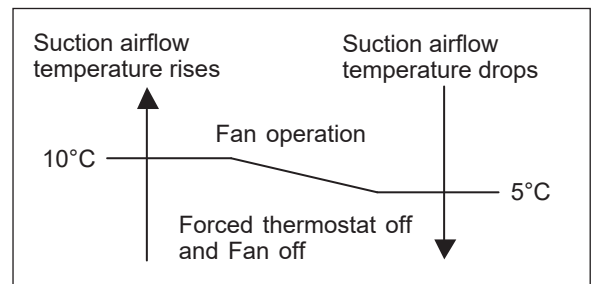

3-7 DX-KIT

3-7-1 SYSTEM CONFIGURATION

1. FGL remote/controller connection

The DX kit is controlled by a VRF operation device and use the external output of the DX kit to perform the AHU operation indirectly.

Control devices can be unified with FGL devices.

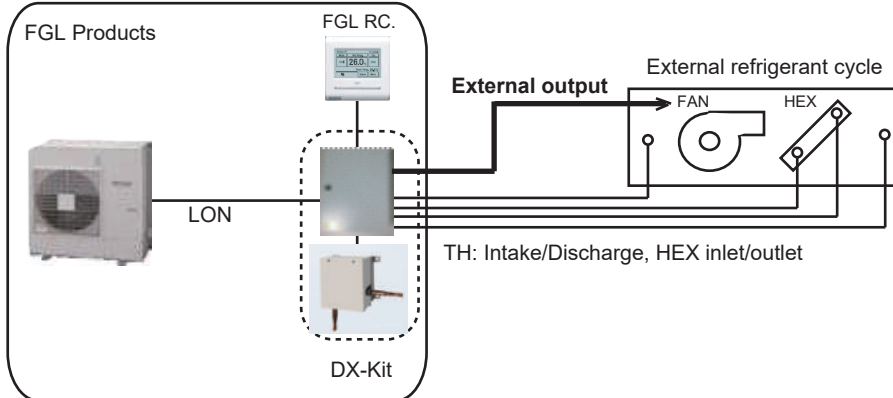

Interface	Contents
External input	Fan abnormal input
External output	Fan ON/OFF
	Thermostat ON/OFF

2. External controller connection

Air conditioning control (thermostat-control) can be designed on-site.

(Air conditioning control by DX is also possible.)

Control equipment suited to the application can be connected.

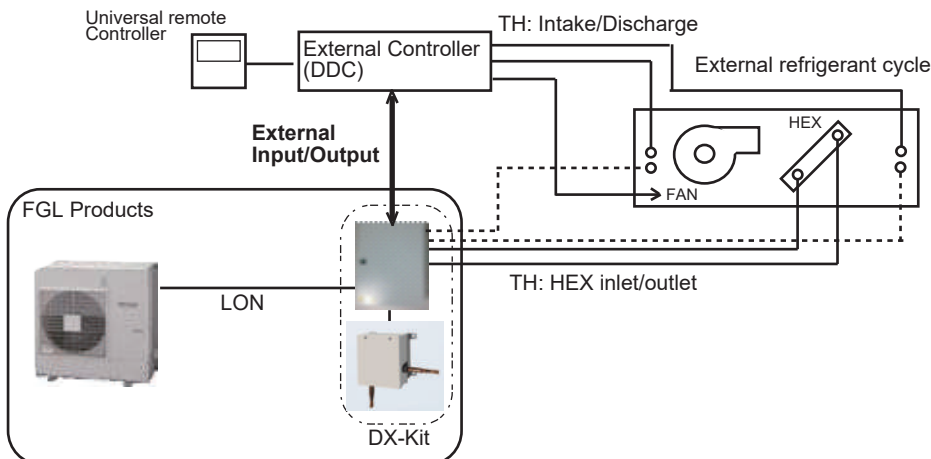

Interface	Contents	Remarks
External input	Operation ON/OFF	
	Operation mode Cool/Heat	Typical indoor unit is required for mode changing.
	Set temperature or capacity request (Analog input)	Temperature setting: When thermo-control is performed by DX kit. Capacity request: When the thermo-control is performed by external controller.
	Error	Information on error occurred at external controller
External output	Operation ON/OFF	
	Error	Information on error occurred at VRF system
	Special operation (defrost)	The Fan operation can be stopped with the communication signal of special operation

3-7-2 FUNDAMENTAL FUNCTIONS

1. FGL remote/controller connection

Air conditioning control system (SET3-3)	Intake temperature control	Discharge temperature control
Set temperature objective	Intake temperature (Room temperature) Cooling: 18 to 30°C Heating: 10 to 30°C	Discharge temperature Cooling: 14 to 25°C Heating: 17 to 28°C
Thermostat OFF conditions	Cooling Intake temperature < Setting temperature -0.5°C Heating Intake temperature > Setting temperature +0.5°C	Cooling Discharge temperature < Setting temperature -5.0°C Heating Discharge temperature > Setting temperature +5.0°C for 5 minutes
Operation (ON/OFF/Mode/ Set temperature)	FGL controller	
Fan control	Fan control commands are output from the DX kit external output terminal	

2. External controller connection

Air conditioning control system (SET3-3)	Intake temperature control	Outlet temperature control	
Analog input system (SET3-2)	Set temperature input / Capacity input Selection	Set temperature input / Capacity input Selection	
Temperature setting	Temperature Setting range	Intake temperature (Room temperature) Cooling: 18 to 30°C Heating: 10 to 30°C	Discharge temperature Cooling: 14 to 25°C Heating: 17 to 28°C
	Thermostat OFF conditions	Cooling Intake temperature < Setting temperature -0.5 °C Heating Intake temperature > Setting temperature +0.5°C	Cooling Discharge temperature < Setting temperature -5.0 °C Heating Discharge temperature > Setting temperature +5.0°C for 5 minutes
Capacity input	Capacity input range	0%, 5% to 100%	
	Thermostat OFF conditions	Controlled by external controller and EEV closed by making the capacity input 0% in cooling mode. EEV slightly opened when the Compressor operating in heating mode	
Operation (ON/OFF/Mode/ Set temperature)	Controlled by external controller, input to DX Kit external input terminal *Operation from FGL controller is disabled. (Only monitoring is possible)		
When error generated at external equipment	When fanmotor locked or another error was generated at the external equipment, the refrigerant cycle is stopped by inputting an error signal to the DX Kit external input terminal. (EEV is Closed)		
Fan control	Control is performed by external equipment, but when you want to stop the fan during defrosting, use the defrost signal that is output from the DX Kit external output terminal.		

3-7-3 FUNDAMENTAL FUNCTIONS

Cooling operation

When using the cooling mode, set the temperature to a value lower than the target controlling temperature, otherwise the External refrigeration cycle equipment will not start the cooling operation.

An example for COOLING TEMPERATURE CONTROL time chart

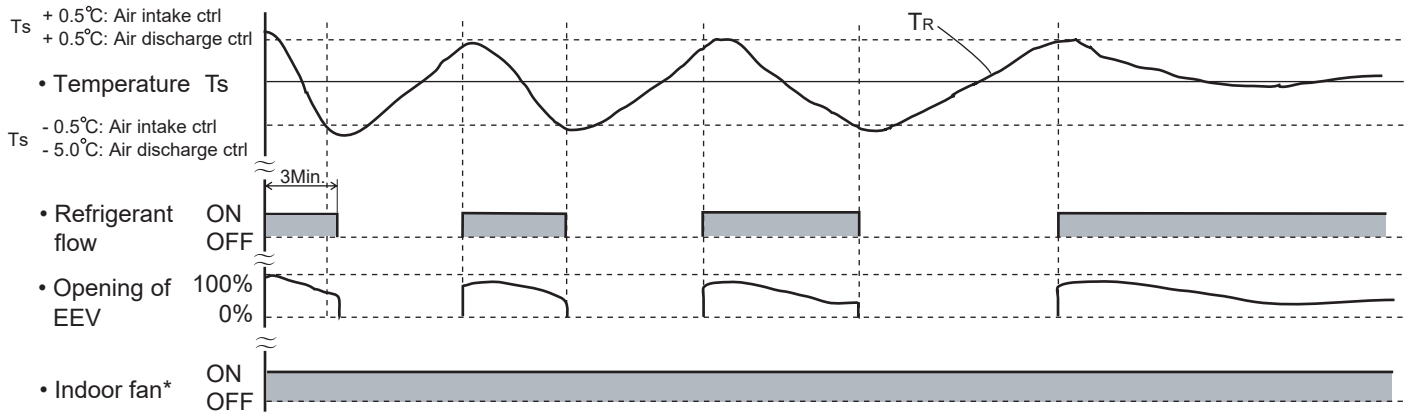

T_R : Target controlling temperature (Air intake temperature or Air discharge temperature)
 T_s : Corrected Setting temperature

Air intake temp controlling

$T_s + 0.5^\circ\text{C}$: The threshold temperature of start of refrigerant flow

$T_s - 0.5^\circ\text{C}$: The threshold temperature of stop of refrigerant flow

Air discharge temp controlling

$T_s + 0.5^\circ\text{C}$: The threshold temperature of start of refrigerant flow

$T_s - 5.0^\circ\text{C}$: The threshold temperature of stop of refrigerant flow

Heating operation

- (1) When using the heating mode, set the temperature to a value higher than the current room temperature, otherwise the indoor unit will not start the heating operation.
- (2) After the start of heating operation, the fan of indoor unit will not rotate until the heater exchange is warmed up to blow out warm air.
- (3) During defrosting, the OPERATION indicator lamp flashes 6 sec. ON and 2 sec. OFF, and repeat. The heating operation will be temporarily interrupted.

An example for HEATING TEMPERATURE CONTROL time chart

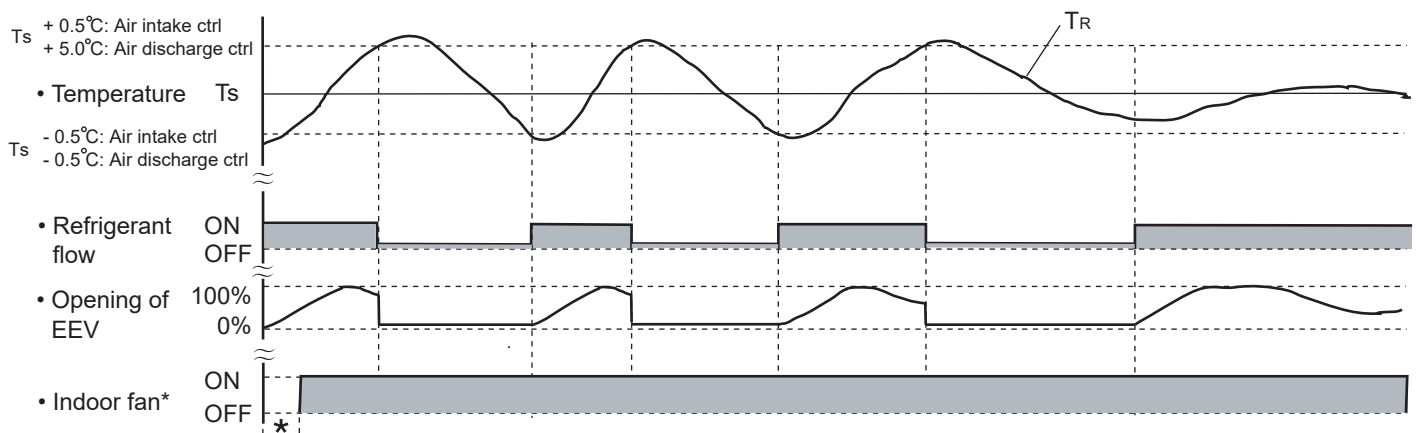

T_s : Corrected Setting temperature * : Duration of cold air prevention

T_R : Target controlling temperature (Air intake temperature or Air discharge temperature)

Air intake temp controlling

$T_s - 0.5^\circ\text{C}$: The threshold temperature of start of refrigerant flow

$T_s + 0.5^\circ\text{C}$: The threshold temperature of stop of refrigerant flow

Air discharge temp controlling

$T_s - 0.5^\circ\text{C}$: The threshold temperature of start of refrigerant flow

$T_s + 5.0^\circ\text{C}$: The threshold temperature of stop of refrigerant flow

*When the EEV operates with the minimum pulse, and it keeps for 5 minutes.

3-7-4 ELECTRICAL EXPANSION VALVE CONTROL for DX-KIT

1. Initialization

- When the power is turned ON.
- When it has passed the limited time since the last initialization.

2. Operation Control

- When indoor unit stopping by Thermo-OFF condition.

Outdoor unit Condition	EEV Condition
OFF	Fully closed
Cooling	Fully closed
Heating	Fully closed

- When starting up
(Cooling) Move to the cooling control base pulse in steps.
(Heating) Move to the heating control base pulse in steps.
- Automatic operatic control
Automatic PI control is performed based on the indoor unit heat exchanger outlet temp and inlet temp.
- Discharge airflow temperature control
The discharge airflow temperature is controlled so that it reaches to the set-up temperature based on the difference between the discharge airflow temperature and the set-up temperature.
Cooling operation: 1) If the discharge airflow temperature becomes 5°C lower than the set-up temperature, EEV is fully closed.
2) If the suction airflow temperature becomes 0.5°C lower than the set-up temperature, EEV is fully closed.
Heating operation: If the suction airflow temperature becomes 0.5°C higher than the set-up temperature, EEV is fully closed.

3. Special Control

- Oil recovery operation : Controlled pulse(Maximum 1400 puls)
- Test run operation : Controlled pulse.
- Freeze prevention control : Fully closed.
- Vacuuming operation : Fully open.
- Defrost operation : Controlled pulse(Maximum 1400 puls)

3-7-5 DARIN PUMP OPERATION for DX-KIT

- (1) When cooling and refrigerant circulation starts, the drain pump starts simultaneously.
- (2) The drain pump operates continuously for 3 minutes after the refrigerant circulation stopped.
- (3) When the refrigent circulation is stopped by a start of indoor heat exchanger frost prevention operation, the drain pump will turn off in 1 hour after the end of indoor heat exchanger frost prevention operation.
- (4) When the water level in the drain pan rises up and then the float switch functions:
 - ① Microcomputer stops the refrigerant circulation and indoor fan motor operation.
 - ② Drain pump operates continuously for 3 minutes after the float switch is turned off.
(Almost condensing water may be drained)
- (5) When the float switch turns ON continuously for 3 minutes, 'FAILURE INDICATION' operates.
- (6) When the float switch turns OFF within 3 minutes, the unit starts cooling operation.

3-7-6 FUNCTION

Auto Restart

The air conditioner restarts with the previous setting operation.

Freeze Prevention Control

The icing of the indoor heat exchanger is prevented during the cooling and dry mode operation.

(1) Starting Condition

- Compressor is operation more than 3 minutes.
When "Heat exchanger inlet temperature $\leq T_A$ " continues *4 minutes or more.
- Compressor is operation more than 3 minutes.
When "Heat exchanger outlet temperature $\leq T_A$ " continues 4 minutes or more.

(2) Operation

EEV is closed.
Fan is at the setting amount.

(3) Completing Condition

Heat exchanger inlet and middle temperature $\geq T_B$
After more than 5 minutes

* Drain pump turns off at 60 minutes past the completion of the icing protection operation.

T_A	T_B
1°C	7°C

Oil Recovery Operation / Defrost Operation

[Oil recovery operation / Defrost operation] :

It periodically returns the residual refrigeration oil in the indoor unit and the connection piping back to the outdoor unit, and prevents the compressor oil level from decreasing.

IR Receiver Unit LED: Operation LED

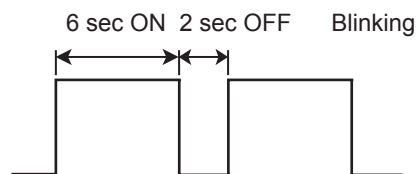

FAN output: Same operation before oil recovery operation in cooling operation or dry operation. (Heating operation: Stop)

DX-KIT EEV: Control pulse

* During the above operation, a refrigerant noise might hear from the EEV Kit.



AIRSTAGE™ J-IIS



Variable Refrigerant Flow System

4.TROUBLE SHOOTING





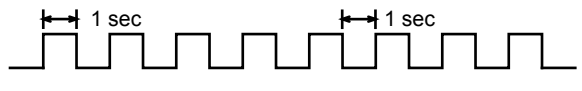
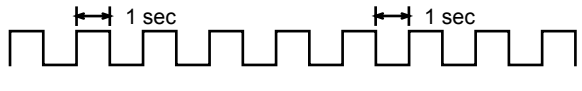
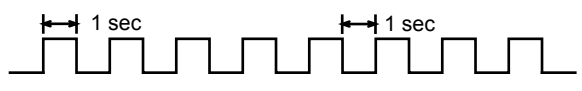
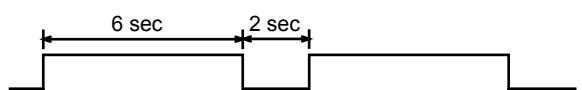

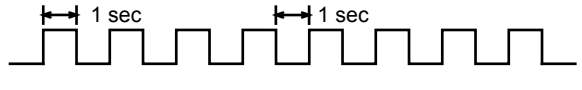
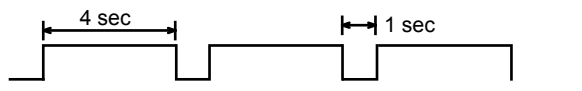





4.TROUBLESHOOTING

4-1 NORMAL OPERATION

4-1-1 Indoor Unit Display

Indication type	Indication Lamp	Flashing Pattern
Operation	Operation LED	Continuous lighting
Anti Freeze		Continuous lighting(lowered light)
Timer	Timer LED	Continuous lighting(lowered light)
Filter	Filter LED	Continuous lighting
Power Failure	Operation LED	ON OFF 
	Timer LED	ON OFF 
Test Operation	Operation LED	ON OFF 
	Timer LED	
Defrosting	Operation LED	ON OFF 
Oil Recovery		
Opposite Operation Mode	Timer LED	ON OFF 
Maintenance Mode	Operation LED	ON OFF 
	Timer LED	
	Filter LED	
Location Notification	Operation LED	ON OFF 
	Timer LED	
	Filter LED	

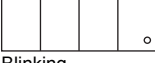
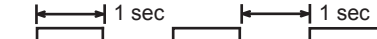
4-1-2 OUTDOOR UNIT DISPLAY

Indication type	7 Segment LED Pattern	Description
Idling(stop)	 Blank	
Cooling Mode	 "C" "OO" "L"	
Heating Mode	 "H" "EA" "T"	
Oil Recovery Operation	 "O" "IL" "R" "ECOVERY"	Refer to 02-10 page for operation.
Defrost Operation	 "D" "E" "F" "ROST"	Refer to 02-11 page for operation.
System stooped with Discharge Temp. Protection	 "P" "ROTECT" "1"	<Starting condition> Discharge temp \geq fixed value: 115°C <Release condition> 3 minutes have elapsed and discharge temperature \leq 80°C
System stopped with High Pressure Protection	 "P" "ROTECT" "2"	<Starting condition> High pressure \geq 4.00MPa <Release condition> 5 minutes have elapsed and high pressure \leq 3.50MPa
System stopped with Low Pressure Protection	 "P" "ROTECT" "3"	<Starting condition> Low pressure \leq 0.05MPa or low pressure \leq 0.10MPa continues for 10 minutes <Release condition> 3 minutes have elapsed and low pressure \geq 0.17MPa
System stopped with compressor Temperature Protection	 "P" "ROTECT" "4"	<Starting condition> Compressor temp \geq fixed value :110°C <Release condition> 3 minutes have elapsed and discharge temperature \leq 80°C
Peak Cut Mode	 "P" "eak" "C" "ut"	
Low Noise Mode	 "L" "OW" "N" "OISE"	Refer to 02-08 page for operation.
Inverter Compressor Operation Indication	 Blinking	ON  OFF 

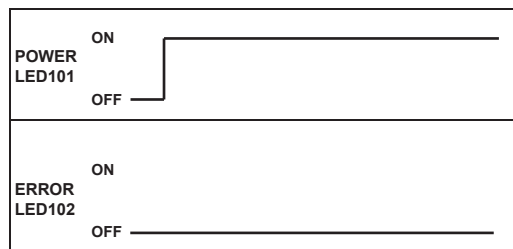
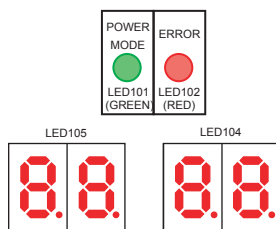

4-2 ABNORMAL OPERATION

4-2-1 Indoor Unit Display

Please refer the flashing pattern as follows.

Error Contents	Operation LED	Timer LED	Filter LED	Trouble shooting
Remote Controller Communication Error	1 times flash	2 times flash	Continuous flash	9
Network Communication Error	1 times flash	4 times flash	Continuous flash	11
Indoor Unit Parallel Communication Error	1 times flash	6 times flash	Continuous flash	10
Indoor Unit Power Frequency Abnormal	3 times flash	1 times flash	Continuous flash	2
Indoor Unit Main PCB Error	3 times flash	2 times flash	Continuous flash	1,3
Room Temperature Sensor Error	4 times flash	1 times flash	Continuous flash	4
Indoor Unit Heat Ex. Sensor Error	4 times flash	2 times flash	Continuous flash	5,6
Indoor Unit Fan Motor Error	5 times flash	1 times flash	Continuous flash	8
Water Drain Abnormal	5 times flash	3 times flash	Continuous flash	7
Damper Error	5 times flash	7 times flash	Continuous flash	112,113
Outdoor Unit Error	9 times flash	15 times flash	Continuous flash	12 ~ 48

Depending on contents of Outdoor unit, it may not indicate. (Refer to "TROUBLE LEVEL OF SYSTEM")

Error Indication Flashing Pattern

Example : Indoor Unit Main PCB Error (Operation LED : 3 times, Timer LED : 2 times)

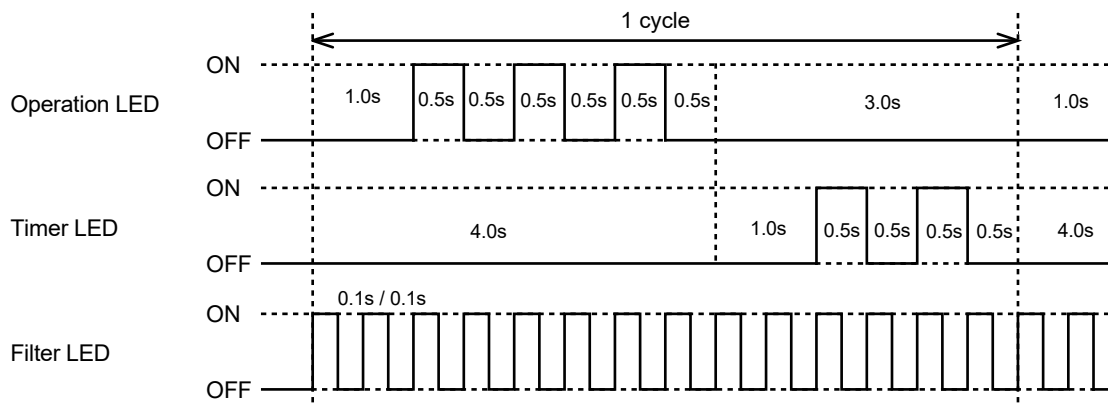

Outdoor Air Unit

Error Contents	Error code		Operation LED	Timer LED	Filter LED	Trouble shooting
	Large division	Small division				
Indoor unit power supply error for fan motor 1	3 9	1	3 times flash	9 times flash	Continuous flash	100
Indoor unit power supply error for fan motor 2	3 9	2	3 times flash	9 times flash	Continuous flash	
Indoor unit suction air temp. thermistor error	4 A	1	4 times flash	10 times flash	Continuous flash	101
Indoor unit discharge air temp. thermistor error	4 A	2	4 times flash	10 times flash	Continuous flash	102
Indoor unit fan motor 2 rotation error	5 9	2	5 times flash	9 times flash	Continuous flash	103
No power	-	-	-	-	-	104

* LED Display when Option receiver unit installed.

Error Contents	Error code	Trouble shooting
Remote controller communication error	1 2	9
Network communication error	1 4	11
Peripheral unit communication error	1 6	10
Indoor unit address setting error	2 6	12
Connection unit number error in WRC system	2 9	13
Indoor unit power supply abnormal	3 1	2
Indoor unit main PCB error	3 2	1, 3
Indoor unit (Communication circuit) WRC error	3 A	14
Indoor unit heat ex. temp. thermistor error	4 2	5, 6
Indoor unit air temp. thermistor error	4 A	101, 102
Indoor unit coil 1 (Expansionvalve) error	5 2	105
Indoor unit coil 2 (Expansionvalve) error	5 2	106
Indoor unit water drain abnormal	5 3	7
Damper error	5 7	112,113
Outdoor unit miscellaneous error	9 U	12~ 48
DX-Kit Error	J 6	107
No Error Code		Trouble shooting
Peripheral device - No Power		108
Peripheral device - FAN does not operate		109
Peripheral device - No cooling/ No Heating		110
DX Kit No Power		111

4-2-2 Outdoor Unit Display

LED display

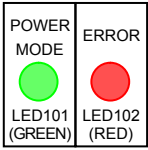

POWER MODE LED : on
ERROR LED : blink

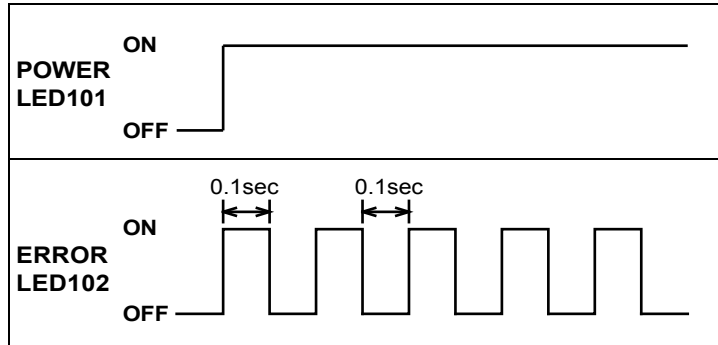

Operation button

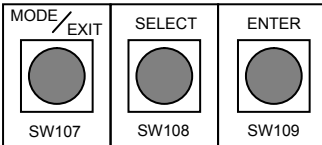

ERROR transition

Short press : less than 3 seconds
Long press : more than 3 seconds

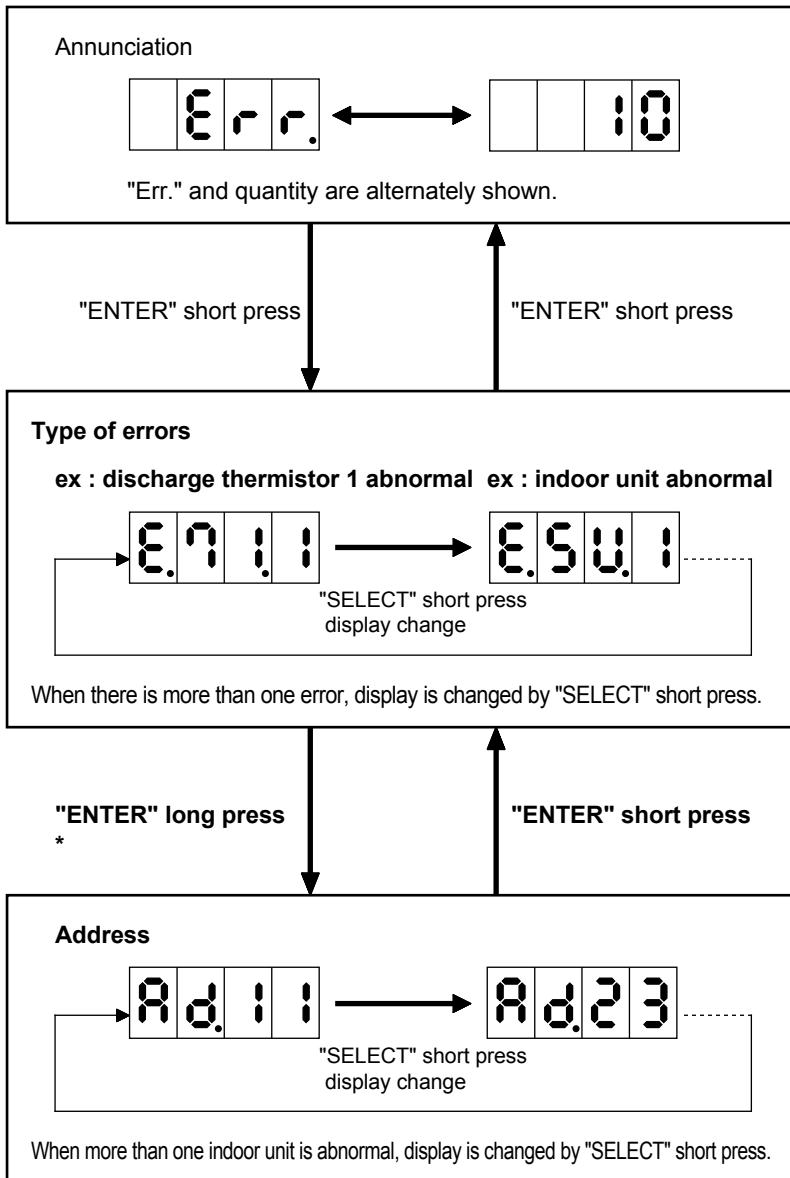

If some error is newly occurred or resolved during transition, it is reflected after going back to "Annunciation".

*Only in the case of "indoor unit abnormal (E.5U.1)", indoor unit address is shown by ENTER long press.

4-2-3 Error Code List for Outdoor Unit

Error Code	Error Contents	Trouble shooting
1 4 . 2	Outdoor Unit Network Communication 2 Error	16
1 4 . 5	The number of Indoor unit shortage	46
2 2 . 1	Connecting indoor units capacity error Error at indoor unit connection check	114
2 4 . 2	Connecting number of indoor unit error Error at indoor unit connection check	
2 6 . 1	Dual address number is existing Error at indoor unit connection check	
2 8 . 1	Auto Address Setting Error	44
2 8 . 4	Signal Amplifier Auto Address Setting Error	45
5 U . 1	Indoor Unit Error	1 - 15 112,113
6 2 . 3	Outdoor Unit EEPROM Access Error	17
6 2 . 6	Inverter Communication Error	18
6 2 . 8	EEPROM Data corrupted Error	19
6 3 . 1	Inverter Error	20
6 7 . 2	Inverter PCB short intereuption detection	21
6 9 . 1	Outdoor Unit transmission PCB Parallel Communication Error	22
7 1 . 1	Discharge Temp. Sensor Error < TH1 >	23
7 2 . 1	Compressor Temp. Sensor Error < TH10 >	24
7 3 . 3	Heat Ex. Liquid pipe Temp. Sensor Error < TH5 >	25
7 4 . 1	Outdoor Temp. Sensor Error < TH3 >	26
7 5 . 1	Suction Gas Temp. Sensor Error < TH4 >	27
7 7 . 1	Heat Sink Temp. Sensor Error < IPM built in >	28
8 4 . 1	Current Sensor Error	29
8 6 . 1	Discharge Pressure Sensor Error	30
8 6 . 3	Suction Pressure Sensor Error	31

Error Code	Error Contents	Trouble shooting
9 3 . 1	Inverter Compressor Start Up Error	32
9 4 . 1	Trip Detection	33
9 5 . 5	Compressor Motor Loss of Synchronization	34
9 7 . 1	Outdoor Unit Fan Motor Lock Error (Start up Error)	35
9 7 . 4	Outdoor unit FAN motor under voltage (Lack of DC Voltage)	36
9 7 . 5	Outdoor Unit Fan Motor Temperature Abnormal	37
9 A . 1	Coil (Expansion Valve) Error	38
A 1 . 1	Discharge Temperature Abnormal	39
A 3 . 1	Compressor Temperature Abnormal	40
A 4 . 1	High Pressure Abnormal	41
A 5 . 1	Low Pressure Abnormal	42
A C . 4	Outdoor unit Heat Sink temp. Abnormal	43

4-2-4 Remote Controller Display

<< SIMPLE REMOTE CONTROLLER >> UTY-RSK *

ERROR CODE DISPLAY

If an error occurs, the following display will be shown.
 ("Er" will appear in the set room temperature display.)
 If "Er" is displayed, immediately contact authorized service personnel.

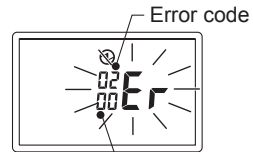

Faulty unit No.
 (Remote controller address)
 Ex. Error code display

<< WIRED REMOTE CONTROLLER 3 wire type>> UTY-RNK *

ERROR CODE DISPLAY

If an error occurs, the following display will be shown.
 ("Er" will appear in the set room temperature display.)
 If "Er" is displayed, immediately contact authorized service personnel.

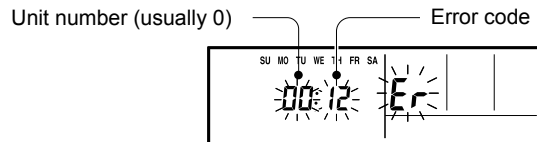

Ex. Error code display

<< WIRED REMOTE CONTROLLER 2 wire type>> UTY-RNR *

If an error occurred, an error icon appears on the Monitor mode screen.

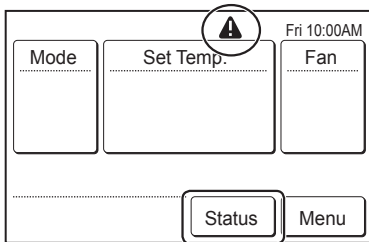

1. Touch the [Status] on the Monitor mode screen.

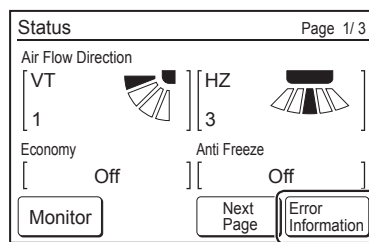

2. Touch the [Error Information] on the Status screen.

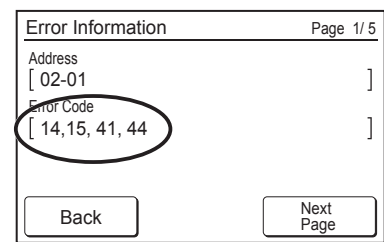

2-digit numbers are corresponding to the error code

<< WIRED REMOTE CONTROLLER 2 wire type>> UTY-RLR *

This appears automatically on the display if an error occurs.

If an error occurs, the following display will be shown. ("▲" will appear in the "Monitor Mode Screen")

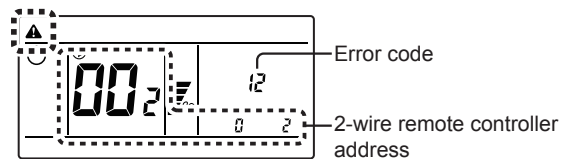

Ex. Error code display

4-2-5 Error Code List for Simple and Wired Remote Controller

Error Code	Error Contents	Trouble shooting
1 2	Remote Controller Communication Error	9, 83
1 4	Network Communication Error	11
1 5	Scan Error	84
1 6	Indoor Unit Parallel Communication Error	10
2 6	Address setting Error	12
2 9	Connection unit number error in wired remote controller system	13
3 1	Indoor Unit Power Frequency Abnormal	2
3 2	Indoor Unit Main PCB Error	1, 3
3 A	Indoor unit communication circuit (WRC) error	14

Error Code	Error Contents	Trouble shooting
4 1	Room Temperature Sensor Error	4
4 2	Indoor Unit Heat Ex. Sensor Error	5, 6
5 1	Indoor Unit Fan Motor Error	8
5 2	Indoor unit Coil (EEV) Error	15
5 3	Water Drain Abnormal	7
9 U	Outdoor Unit Error	16 ~ 52

4-2-6 TROUBLE LEVEL OF SYSTEM

<< System Condition when Outdoor Unit Error is occurred >>

System Condition	Outdoor unit Condition	Trouble Level	
		1	2
		(1) Not indicated on Indoor Unit. Not indicated on Peripheral Unit. Indicated on Service Tool.	(2) ● Indicated on Indoor Unit. Indicated on Peripheral. Indicated on Service Tool.
System is not stopped compulsorily	>Abnormal >LED indication >Outdoor unit does not stop	(Not available)	> Suction gas Temp sensor error > Outdoor Temp sensor error > Sub-cool heat Ex. gas inlet Temp sensor error > Sub-cool heat Ex. gas outlet Temp sensor error
	>Abnormal >LED indication >Outdoor unit does not stop	>Temporary blackout detection protection (Inverter compressor stop)	> Discharge temperature abnormal (Inverter compressor stops) > Compressor temperature abnormal (Inverter compressor stops) > High pressure switch error (Inverter compressor stops) > High pressure switch error (Constant speed compressor stops) > Discharge Temp sensor error (Inverter compressor stops) > Compressor Temp sensor error (Inverter compressor stop) > Heat sink Temp sensor error (Inverter compressor stop) > Current sensor error (Inverter compressor stop) > High pressure switch error (Inverter compressor stop) > Inverter error (Inverter compressor stop) > Heat sink temperature abnormal (Inverter compressor stop) > Inverter compressor start up error (Inverter compressor stop) > Trip detection (Inverter compressor stops) > Rush current limiting resistor Temp rise protection (Inverter compressor stop) > Comp. motor loss of synchronization (Inverter compressor stop) > Inverter communication error (Inverter compressor stop) > Outdoor unit EEPROM access error > Outdoor unit EEPROM data corrupted > Indoor unit number shortage

● This will not be displayed on indoor unit which Error Report Target(function setting 47 of indoor unit) is set "for administrator".

System Condition	Outdoor unit Condition	Trouble Level	
		1	2
		(1) Not indicated on Indoor Unit. Not indicated on Peripheral Unit. Indicated on Service Tool.	(2) Indicated on Indoor Unit. Indicated on Peripheral. Indicated on Service Tool.
System is compulsorily stopped.	<ul style="list-style-type: none"> >Abnormal >LED indication >Outdoor unit stops >Need to repair >secondary accident is possible. 	(Not available)	<ul style="list-style-type: none"> >High pressure abnormal >Low pressure abnormal >Fan motor 1 lock error >Fan motor 2 lock error >Fan motor 1 temp. abnormal >Fan motor 2 temp. abnormal >Heat Ex. liquid Temp sensor error >Discharge pressure sensor error >Suction pressure sensor error >Outdoor unit communication PCB parallel communication error >Outdoor unit network communication 2 error >Lack of DC Voltage >Indoor unit number shortage >SC HE. Liquid Outlet Temp Sensor Error

<Important>

Even if power is reset, the following Error cannot release.

- Discharge temperature abnormal
- Compressor temperature abnormal
- Current sensor error
- Inverter compressor start up error
- Trip detection
- Rush current limiting resistor Temp rise protection
- Comp. motor loss of synchronization
- Low pressure abnormal
- Fan motor 1 lock error
- Fan motor 2 lock error

These errors can not be judged without operating the system, and the serviceman would not be able to check it if the system power is turned off before visiting the site for repair. In Error release, you need to operate push switch and apply "Error reset" (F3-40) after power restart.

4-2-7 ERROR HISTORY MODE

When the abnormality occurred, the J2 system memorizes the history of error codes up to 10 and it can be displayed on 7 segments LED. It is an effective means to examine abnormality that occurred in the past.

*The error history can be cleared by setting to F3-30.

Refer to the following for the procedure.

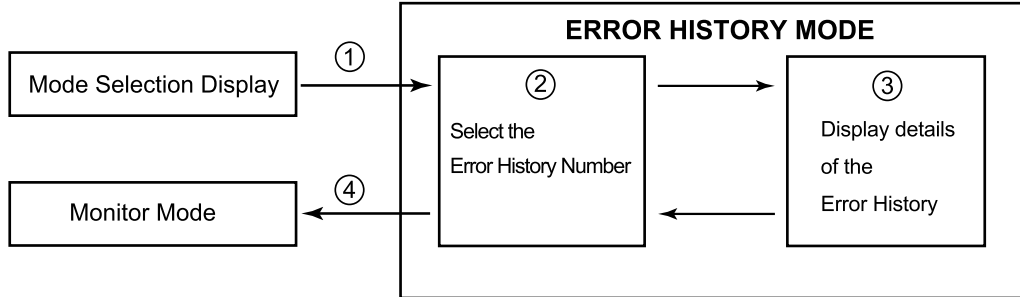

① Change to the Error History Mode from the Mode Selection Display

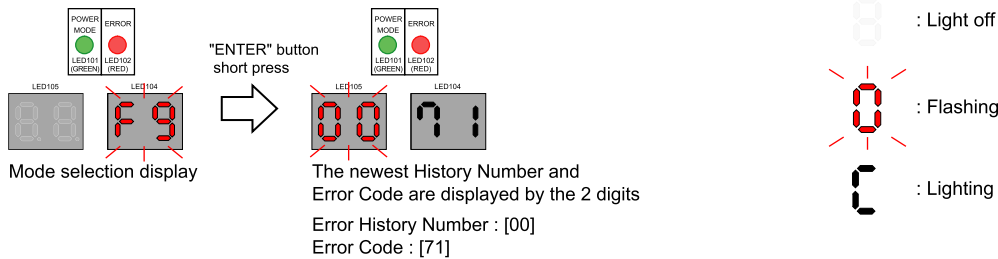

② Select the Error History Number

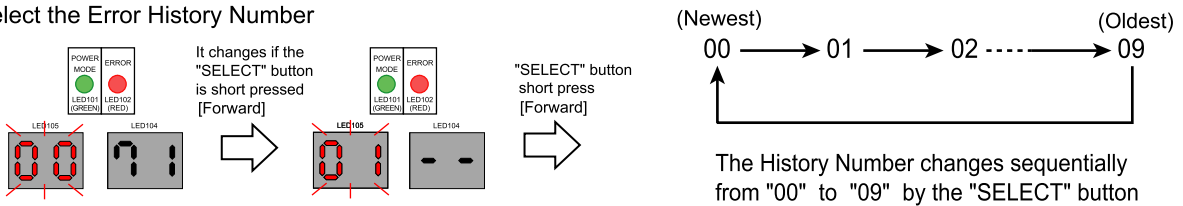

③ Check the detail of the Error History

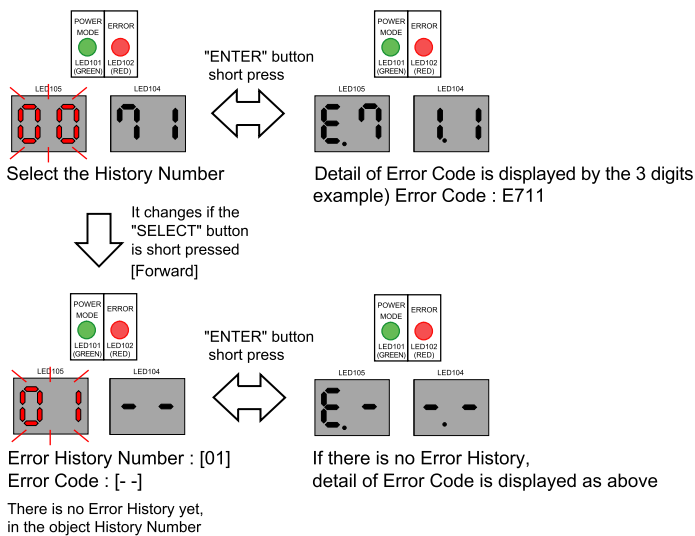

④ End of the Error History mode

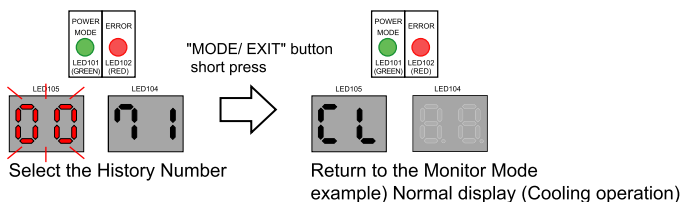

4-3 TROUBLE SHOOTING

4-3-1 Trouble shooting with error code (INDOOR UNIT)

Trouble shooting 1 INDOOR UNIT Error Method: Model Information Error (Indoor Unit Main PCB Error)	Indicate or Display: Outdoor Unit : E.5 U.1 Indoor Unit : Operation LED 3 times Flash, Timer LED 2 Times Flash, Filter LED Continuous Flash. Error Code : 3 2
--	--

Detective Actuators: Indoor Unit Controller PCB Circuit	Detective details: 3 continuous failure of read test of EEPROM at Power ON, or Apparent Model information error from EEPROM. Also, Error on Model information upon model information test of EEPROM, or Model information of EEPROM not possible to recover.
---	--

Forecast of Cause : 1. Outside cause 2. Connection failure of electric components 3. Controller PCB defective

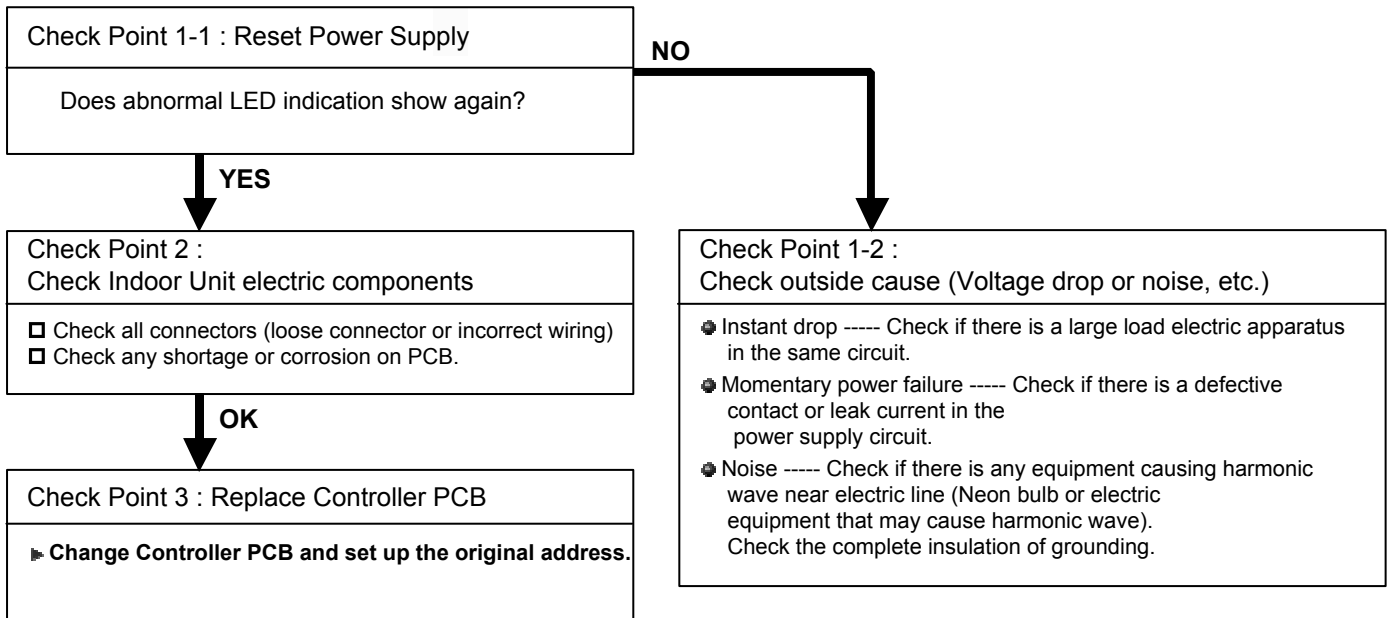

Note : EEPROM

EEPROM(Electronically Erasable and Programmable Read Only Memory) is a non-volatile memory which keeps memorized information even if power is turned off. It can change the contents electronically. To change the contents, it uses higher voltage than normal, and it can not change a partial contents. (Rewriting shall be done upon erasing the all contents.) There is a limit in a number of rewriting.

Trouble shooting 2 INDOOR UNIT Error Method: Power Frequency Abnormal	Indicate or Display: Outdoor Unit : E.5 U.1 Indoor Unit : Operation LED 3 times Flash, Timer LED 1 Times Flash, Filter LED Continuous Flash. Error Code : 3 1
--	--

Detective Actuators: Indoor Unit Controller PCB Circuit	Detective details: When 5 continuous failures occurred at Power frequency test.
---	---

Forecast of Cause : 1. Outside cause 2. Installation failure 3. Defective connection of electric components
4. Controller PCB defective

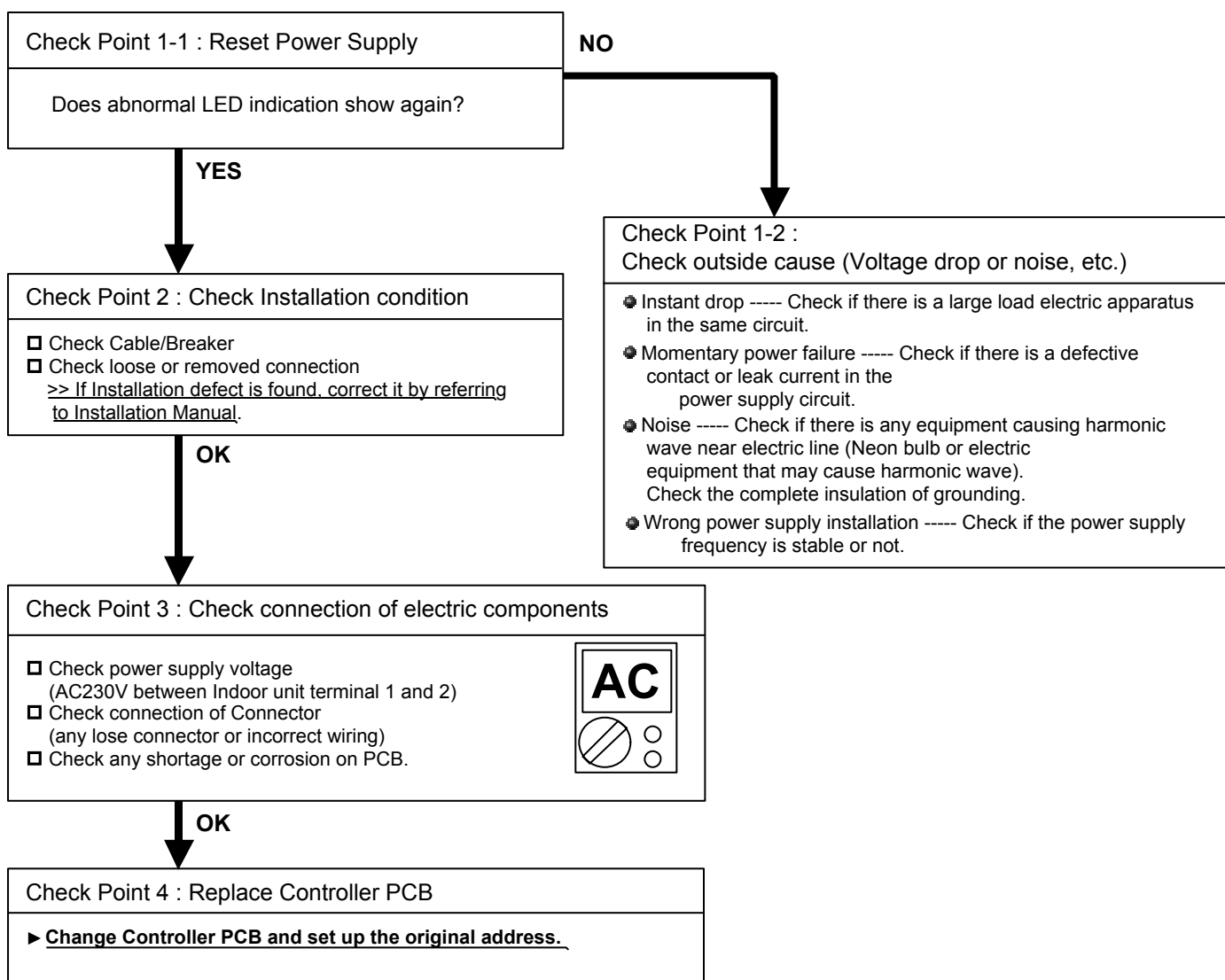

Trouble shooting 3 INDOOR UNIT Error Method: EEPROM Access Abnormal (Indoor Unit Main PCB Error)	Indicate or Display: Outdoor Unit : E.5 U.1 Indoor Unit : Operation LED 3 times Flash, Timer LED 2 Times Flash, Filter LED Continuous Flash. Error Code : 3 2
---	--

Detective Actuators: Indoor Unit Controller PCB Circuit	Detective details: When 3 continuous failure occurred on read test of EEPROM.
---	---

Forecast of Cause : 1. Outside cause 2. Defective connection of electric component 3. Controller PCB defective

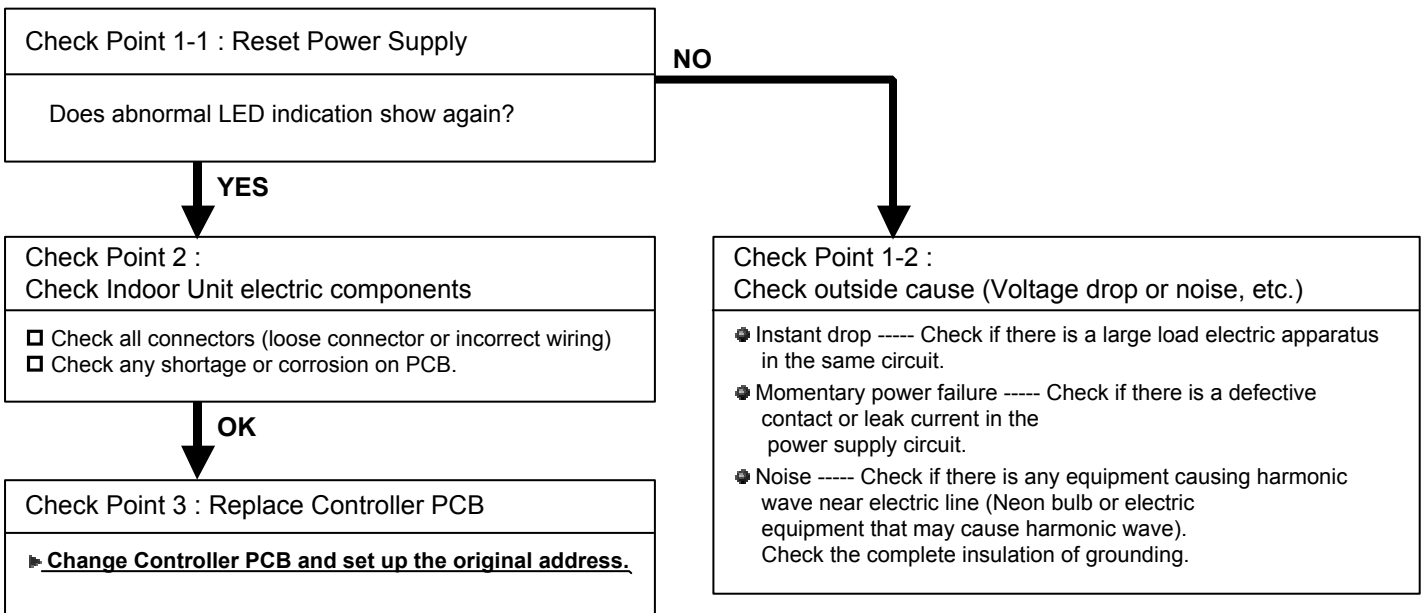

Trouble shooting 4 <u>INDOOR UNIT Error Method:</u> Room Temperature Sensor Error	<u>Indicate or Display:</u> Outdoor Unit : E.5 U.1 Indoor Unit : Operation LED 4 times Flash, Timer LED 1 Time Flash, Filter LED Continuous Flash. Error Code : 4 1
--	--

<u>Detective Actuators:</u> Indoor Unit Controller PCB Circuit Indoor Temperature Thermistor	<u>Detective details:</u> When Indoor thermistor open or shortage is detected at power ON.
---	--

<u>Forecast of Cause :</u> 1. Connector defective connection 2. Thermistor defective 3. Controller PCB defective
--

Check Point 1 : Check connection of Connector
<input type="checkbox"/> Check if connector is loose or removed <input type="checkbox"/> Check erroneous connection <input type="checkbox"/> Check if thermistor cable is open >>Reset Power when reinstalling due to removed connector or incorrect wiring.



Check Point 2 : Remove connector and check Thermistor resistance value											
Thermistor Characteristics (Rough value)											
Temperature (°C)	0	5	10	15	20	25	30	35	40	45	50
Resistance Value (k Ω)	33.6	25.2	20.1	15.8	12.5	10.0	8.0	6.5	5.3	4.3	3.5
► If Thermistor is either open or shorted, replace it and reset the power.											



Check Point 3 : Check voltage of Controller PCB (DC5.0V)					
Corresponding connector					
<table border="1"> <tr> <th>Model Type</th> <th>Room temp. Sensor (Black Wires)</th> </tr> <tr> <td> Cassette type Duct type Compact Wall mounted type Wall mounted type Floor / Ceiling type Compact Floor type </td> <td style="text-align: center; vertical-align: middle;"> CN8 </td> </tr> </table>	Model Type	Room temp. Sensor (Black Wires)	Cassette type Duct type Compact Wall mounted type Wall mounted type Floor / Ceiling type Compact Floor type	CN8	
Model Type	Room temp. Sensor (Black Wires)				
Cassette type Duct type Compact Wall mounted type Wall mounted type Floor / Ceiling type Compact Floor type	CN8				
► If the voltage does not appear, replace Controller PCB and set up the original address.					

Trouble shooting 5 INDOOR UNIT Error Method: Heat Exchanger Inlet Sensor Error	Indicate or Display: Outdoor Unit : E.5 U.1 Indoor Unit : Operation LED 4 times Flash, Timer LED 2 Times Flash, Filter LED Continuous Flash. Error Code : 4 2
---	--

Detective Actuators: Indoor Unit Controller PCB Circuit Heat Exchanger Inlet Thermistor	Detective details: When open or shorted Heat Exchanger Inlet Thermistor is detected at power ON.
--	--

Forecast of Cause : 1. Connector defective connection 2. Thermistor defective 3. Controller PCB defective

Check Point 1 : Check connection of Connector
<input type="checkbox"/> Check if connector is loose or removed <input type="checkbox"/> Check erroneous connection <input type="checkbox"/> Check if thermistor cable is open >>Reset Power when reinstalling due to removed connector or incorrect wiring.



Check Point 2 : Remove connector and check Thermistor resistance value											
Thermistor Characteristics (Rough value)											
Temperature (°C)	0	5	10	15	20	25	30	35	40	45	50
Resistance Value (kΩ)	168.6	129.8	100.9	79.1	62.5	49.8	40.0	32.4	26.3	21.2	17.8
► If Thermistor is either open or shorted, replace it and reset the power.											



Check Point 3 : Check voltage of Controller PCB (DC5.0V)															
Corresponding connector															
<table border="1"> <thead> <tr> <th>Model Type</th> <th>Heat Ex Inlet temp. Sensor (Black Wires)</th> </tr> </thead> <tbody> <tr> <td>Cassette type</td> <td>CN5 or CN9</td> </tr> <tr> <td>Duct type</td> <td>CN9</td> </tr> <tr> <td>Compact Wall mounted type</td> <td>CN5 or CN20</td> </tr> <tr> <td>Wall mounted type</td> <td>CN5 or CN9</td> </tr> <tr> <td>Floor / Ceiling type</td> <td>CN9</td> </tr> <tr> <td>Compact Floor type</td> <td>CN5</td> </tr> </tbody> </table>	Model Type	Heat Ex Inlet temp. Sensor (Black Wires)	Cassette type	CN5 or CN9	Duct type	CN9	Compact Wall mounted type	CN5 or CN20	Wall mounted type	CN5 or CN9	Floor / Ceiling type	CN9	Compact Floor type	CN5	
Model Type	Heat Ex Inlet temp. Sensor (Black Wires)														
Cassette type	CN5 or CN9														
Duct type	CN9														
Compact Wall mounted type	CN5 or CN20														
Wall mounted type	CN5 or CN9														
Floor / Ceiling type	CN9														
Compact Floor type	CN5														
► If the voltage does not appear, replace Controller PCB and set up the original address.															

Trouble shooting 6 <u>INDOOR UNIT Error Method:</u> Heat Exchanger Outlet Sensor Error	<u>Indicate or Display:</u> Outdoor Unit : E.5 U.1 Indoor Unit : Operation LED 4 times Flash, Timer LED 2 Times Flash, Filter LED Continuous Flash. Error Code : 4 2
---	---

<u>Detective Actuators:</u> Indoor Unit Controller PCB Circuit Heat Exchanger Inlet Thermistor	<u>Detective details:</u> When open or shorted Heat Exchanger outlet Thermistor is detected at power ON.
---	--

Forecast of Cause :
 1. Connector defective connection 2. Thermistor defective 3. Controller PCB defective

Check Point 1 : Check connection of Connector

- Check if connector is loose or removed
- Check erroneous connection
- Check if thermistor cable is open

>>Reset Power when reinstalling due to removed connector or incorrect wiring.



Check Point 2 : Remove connector and check Thermistor resistance value

Thermistor Characteristics (Rough value)

Temperature (°C)	0	5	10	15	20	25	30	35	40	45	50
Resistance Value (k Ω)	168.6	129.8	100.9	79.1	62.5	49.8	40.0	32.4	26.3	21.2	17.8

► If Thermistor is either open or shorted, replace it and reset the power.



Check Point 3 : Check voltage of Controller PCB (DC5.0V)

Corresponding connector

Model Type	Heat Ex Outlet temp. Sensor (Gray Wires)
Cassette type	CN5 or CN9
Duct type	CN9
Compact Wall mounted type	CN5 or CN21
Wall mounted type	CN5 or CN9
Floor / Ceiling type	CN9
Compact Floor type	CN5

► If the voltage does not appear, replace Controller PCB and set up the original address.



Trouble shooting 7 <u>INDOOR UNIT Error Method:</u> Water Drain Abnormal	<u>Indicate or Display:</u> Outdoor Unit : E.5 U.1 Indoor Unit : Operation LED 5 times Flash, Timer LED 3 Times Flash, Filter LED Continuous Flash. Error Code : 5 3
---	---

<u>Detective Actuators:</u> Indoor Unit Controller PCB Circuit Float Switch	<u>Detective details:</u> When Float switch is ON for more than 3 minutes.
--	--

<u>Forecast of Cause :</u> 1. Float switch defective 2. Shorted connector/wire 3. Controller PCB defective 4. Drain pump defective
--

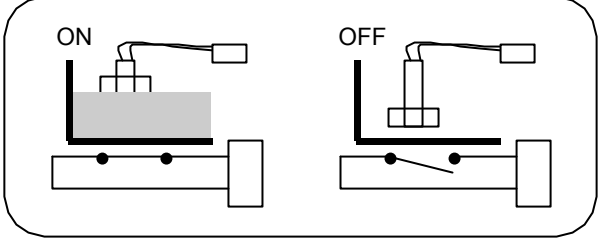
Check Point 1 : Check Float Switch	
<ul style="list-style-type: none"> ❑ Check operation of float switch. (any blocking by dust, etc.) ❑ Remove Float switch and check ON/OFF switching operation by using a meter. >><u>If Float switch is defective, replace it.</u> 	

↓ **OK**

Check Point 2 : Check Connector (CNA05) / Wire
<ul style="list-style-type: none"> ❑ Check loose contact of CNA05 /shorted wire (pinched wire). >><u>Replace Float switch if the wire is abnormal.</u>

↓ **OK**

Check Point 3 : Check Controller PCB
<ul style="list-style-type: none"> ▶ <u>If Check Point 1 & 2 do not improve the symptom, change Controller PCB and set up the original address.</u>

<p><u>Attention!!</u> Small size wall mount type does not have a float switch. In this case, replace Controller PCB and set up the original address. Please refer to.</p>

Trouble shooting 8 INDOOR UNIT Error Method: Indoor Unit Fan Motor Error	Indicate or Display: Outdoor Unit : E.5 U.1 Indoor Unit : Operation LED 5 times Flash, Timer LED 1 Times Flash, Filter LED Continuous Flash. Error Code : 5 1
---	--

Detective Actuators: Indoor Unit Controller PCB Circuit Indoor Fan Motor	Detective details: When Indoor fan control is either phase control or DC control and rotation feed back control is ON, the feed back rotation value becomes 0 and lasts for more than 1 minute at motor operation condition. Or, the feed back rotation value continues at 1/3 of target value for more than 1 minute.
---	--

Forecast of Cause : 1. Fan rotation failure 2. Fan motor winding open 3. Motor protection by surrounding temp. increase 4. Capacitor failure 5. Control PCB failure

Check Point 1 : Check rotation of Fan

Rotate the fan by hand when operation is off.
 (Check if fan is caught, dropped off or locked motor)
>>If Fan or Bearing is abnormal, replace it.



Check Point 2 : Check Motor winding

Check Indoor Fan motor
 Refer to the Service parts information.



Check Point 3 : Check ambient temp. around motor

Check excessively high temperature around the motor.
 (If there is any surrounding equipment that causes heat)
>>Upon the temperature coming down, restart operation.



Check Point 4 : Check Motor Capacitor

Check continuity of motor capacitor
>>If it is shorted, replace the capacitor.



Check Point 5 : Replace Controller PCB

Change Controller PCB and set up the original address.

Attention!!
 In case of Duct type, replace Controller PCB and set up the original address, since it is a tapping control.

Trouble shooting 9 INDOOR UNIT Error Method: Wired Remote Controller Communication Error	Indicate or Display: Outdoor Unit : E.5 U.1 Indoor Unit : Operation LED 1 times Flash, Timer LED 2 Times Flash, Filter LED Continuous Flash. Error Code : 1 2
---	--

Detective Actuators: Indoor unit controller PCB circuit Wired Remote Control (3 wire / 2 wire type)	Detective details: Upon receiving the signal more than 1 time from Wired Remote or other Indoor unit, but the same signal has not been received more than 1 minute.
--	---

Forecast of Cause : 1. Terminal connection abnormal 2. Wired Remote Control failure 3. Controller PCB failure

Check Point 1 : Check the connection of terminal
After turning off the power, check & correct the followings. <input type="checkbox"/> Indoor Unit - Check the connection of terminal between remote control and Indoor unit, or between Indoor units, and check if there is a disconnection or short of the cable.



Check Point 2 : Check Remote and Controller PCB	
<input type="checkbox"/> Check terminal voltage of controller PCB Connector CNC01. (Power supply for Remote) If DC12V, Remote Control failure (Controller PCB is OK) >>> Replace Remote If DC0V, Controller PCB failure (Remote is OK) >>> Replace Controller PCB ▶ In case of re-installation is done due to removed connector or incorrect wiring, turn on the power again.	

Trouble shooting 9 INDOOR UNIT Error Method: Wired Remote Controller Token Error	Indicate or Display: Indoor Unit : Operation LED 1 times Flash, Timer LED 2 Times Flash, Filter LED Continuous Flash. Outdoor Unit : E.5 U.1, Error LED Continuous Flash. Remote Controller : 1 2
---	--

Detective Actuators: Indoor unit Controller PCB circuit Wired Remote Control (3 wire type)	Detective details: More than 1 time of Token (Communication between wired remote controllers) is received, but it was not received more than 1 minute.
---	--

Forecast of Cause : 1. Terminal connection abnormal 2. Mis-setting 3. Wired Remote Control failure 4. Controller PCB failure
--

Check Point 1 : Check the connection of terminal
After turning off the power, check & correct the followings. <input type="checkbox"/> Indoor Unit - Check the connection of terminal between remote control and Indoor unit, or between Indoor units, and check if there is a disconnection or short of the cable.



Check Point 2 : Check Remote and Controller PCB	
<input type="checkbox"/> Check terminal voltage of controller PCB Connector CNC01. (Power supply for Remote) If DC12V, Remote Control failure (Controller PCB is OK) >>> Replace Remote If DC0V, Controller PCB failure (Remote is OK) >>> Replace Controller PCB ▶ In case of re-installation is done due to removed connector or incorrect wiring, turn on the power again.	

Trouble shooting 10 INDOOR UNIT Error Method: Indoor Unit Parallel Communication Error	Indicate or Display: Outdoor Unit : E.1 4.1, 1 4.2 * Indoor Unit : Operation LED 1 times Flash, Timer LED 6 Times Flash, Filter LED Continuous Flash. Error Code : 1 6 *
--	--

* Outdoor unit indicates 1 4.1 or 14.2 (No communication from Indoor unit)
Peripheral device indicates 1 6 (1 6.4 Error)
Service Tool indicates 14.3 (Missing Error Indoor unit)

Detective Actuators: Indoor unit Controller PCB circuit Indoor unit Communication PCB	Detective details: When Parallel communication error (Communication reset occurs continuously more than specified times) is detected.
--	---

Forecast of Cause : 1. Connection failure 2. Outside cause 3. Communication PCB failure 4. Controller PCB failure

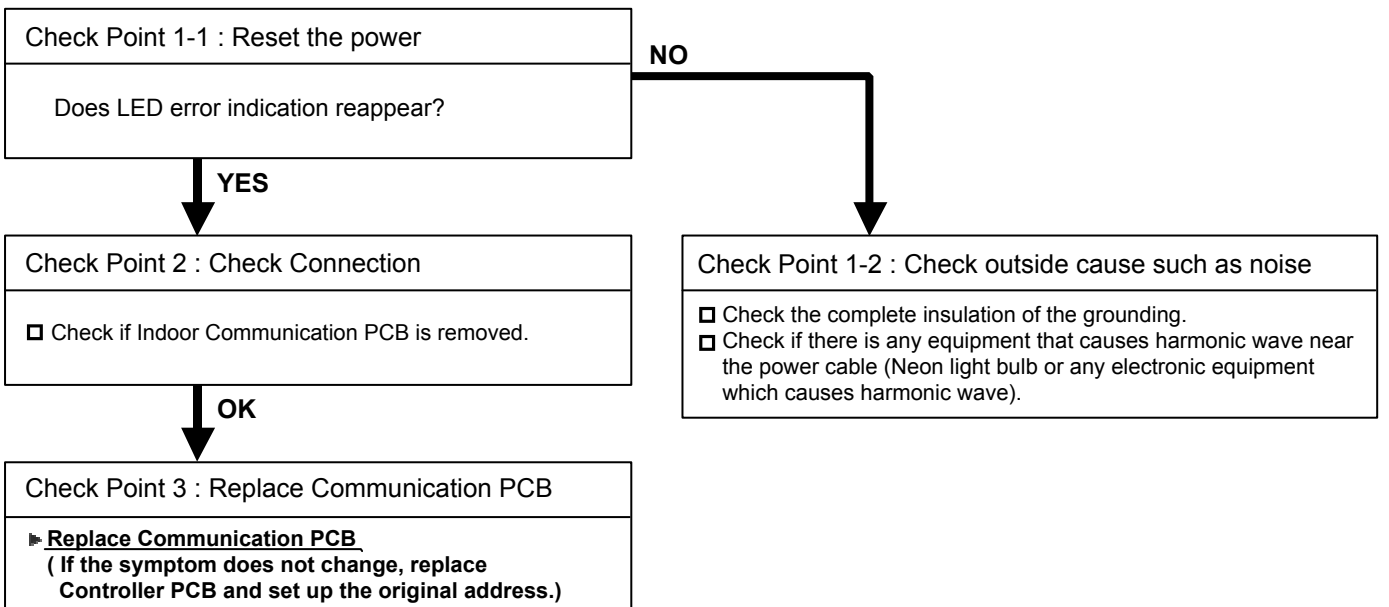

Trouble shooting 11 INDOOR UNIT Error Method: Network Communication Error	Indicate or Display: Outdoor Unit : E.1 4. 1 / 1 4. 2 * Indoor Unit : Operation LED 1 times Flash, Timer LED 4 Times Flash, Filter LED Continuous Flash. Error Code : 1 4 / 1 6 / 9 U / 14.1 / 14.2 / 14.3 *
--	---

* Outdoor unit indicates 1 4.1 or 1 4.2 (No communication from 14.3 Error Indoor unit)
Peripheral device indicates 1 4 or 1 6

Detective Actuators: Indoor unit Controller PCB circuit Indoor unit Communication PCB	Detective details: When the cut-off of network communication is detected (more than 90 seconds passed since the last receipt of Outdoor unit signal).
--	---

Forecast of Cause : 1. Connection failure 2. Outside cause 3. Communication PCB failure 4. Controller PCB failure

Check Point 1 : Check the connection
After turning off the power, check and correct followings. <input type="checkbox"/> Is Indoor Communication PCB loose? <input type="checkbox"/> Check loose or removed connection of communication line between Indoor and Outdoor unit. <input type="checkbox"/> When the signal amplifier is connected , is it failure of signal amplifier?



Check Point 2 : Check if any outside cause such as voltage drop or noise
<ul style="list-style-type: none"> ● Instant voltage drop ----- Check if there is any electric equipment with a large load within the same circuit. ● Momentary power failure ----- Check contact failure or leak current in power supply circuit >>Check Outdoor Unit as well. ● Check if there is any equipment that causes harmonic wave near the power cable (Neon light bulb or any electronic equipment which causes harmonic wave). And check the complete insulation of grounding. >>If the same symptom does not reappear after resetting the power, possibility of noise is high.



Check Point 3 : Check Communication PCB and Controller PCB
<input type="checkbox"/> If some of Indoor units have errors, replace Communication PCB of the Indoor units that have the error. >>If the symptom does not change, replace Indoor unit Controller PCB. <input type="checkbox"/> If all the Indoor units have error, check if the Outdoor Unit Communication PCB has a loose connection. >>If the symptom does not change, replace Outdoor unit Communication PCB (Replace Controller PCB if it does not change).

Trouble shooting 12 INDOOR UNIT Error Method: Address setting Error in Wired remote controller system	Indicate or Display: Outdoor Unit : E.5 U.1 Indoor Unit : Operation LED 2 times Flash, Timer LED 6 Times Flash, Filter LED Continuous Flash. Error Code : 2 6
--	--

Detective Actuators: Wired remote controller (2-Wire) Indoor unit Controller PCB circuit	Detective details: When the address number set by auto setting and manual setting are mixed in one RC group. When the duplicated address number exists in one RC group.
---	--

Forecast of Cause : 1. Wrong wiring of RCgroup 2. Wrong remote address setting 3. Indoor unit controller PCB failure
4. Remote controller failure

Check Point 1 : Wire installation
<input type="checkbox"/> Wrong wire connection in RCgroup (Please refer to the installation manual)



Check Point 2 : Wrong RCgroup setting
<input type="checkbox"/> The given address number by auto setting (00) and the manual set number (Except 00) were not existing in one RCG. <input type="checkbox"/> The remote controller address setting by U.I. were not existing same address. <input type="checkbox"/> The duplicated address number is not existing in one RCgroup



Check Point 3 : Check Indoor unit controller PCB
<input type="checkbox"/> Check if controller PCB damage <input type="checkbox"/> Change controller PCB and check the Error after setting remote controller address

Trouble shooting 13 INDOOR UNIT Error Method: Connection unit number error in Wired remote controller system	Indicate or Display: Outdoor Unit : E.5 U.1 Indoor Unit : Operation LED 2 times Flash, Timer LED 9 Times Flash, Filter LED Continuous Flash. Error Code : 2 9
---	--

Detective Actuators: Wired remote controller (2-Wire) Indoor unit Controller PCB circuit	Detective details: When the number of connecting indoor units are out of specified rule.
---	--

Forecast of Cause : 1. Wrong wiring/ Number of I.U, RC in RCgroup 2. Indoor unit controller PCB defective

Check Point 1 : Wire installation
<input type="checkbox"/> Wrong number of connecting indoor unit



Check Point 2 : Check Indoor unit controller PCB
<input type="checkbox"/> Check if controller PCB damage <input type="checkbox"/> Change controller PCB and check the Error after setting remote controller address

Trouble shooting 14 <u>INDOOR UNIT Error Method:</u> Indoor unit communication circuit (WRC) error	<u>Indicate or Display:</u> Outdoor Unit : E.5 U.1 Indoor Unit : Operation LED 3 times Flash, Timer LED 10 Times Flash, Filter LED Continuous Flash. Error Code : 3 A
--	---

Detective Actuators: Wired remote controller (2-Wire) Indoor unit Controller PCB circuit	Detective details: When the indoor unit(s) detects the configuration of RCG abnormal or the indoor unit detects lack of primary -remote controller.
---	---

Forecast of Cause : 1. Terminal connection abnormal 2. Wired remote controller failure
3. Indoor unit controller PCB defective

Check Point 1 : Check the connection of terminal

After turning off the power supply, check & correct the followings

- ❑ Indoor unit - Check the connection of terminal between remote control and indoor unit, or between Indoor units and check if there is a disconnection or short of the cable



Check Point 2 , 3: Check Indoor unit controller PCB

- ❑ Check terminal voltage of controller PCB connector CNC01 (Power supply for remote)
If DC12V, Remote control failure (Controller PCB is OK) >>> Replace Remote controller
If DC0V, Controller PCB failure (Remote is OK) >>> Replace Controller PCB

In case of re-installation is done due to removed connector or incorrect wiring, turn on the power again.

Trouble shooting 15 INDOOR UNIT Error Method: Indoor unit Coil (EEV) Error	Indicate or Display: Outdoor Unit : E.5U.1 Indoor Unit : Operation LED 5 times Flash, Timer LED 2 Times Flash, Filter LED Continuous Flash. Error Code : 5 2
---	---

Detective Actuators: Indoor unit controller PCB	Detective details: When the EEV1 drive circuit is open circuit
---	--

Forecast of Cause :	1. EEV coil lose connection 2. EEV wire(s) cut or pinched 3. Defective EEV coil 4. Controller PCB (DC 12V) output abnormal 5. Noise momentary open, voltage drop
----------------------------	--

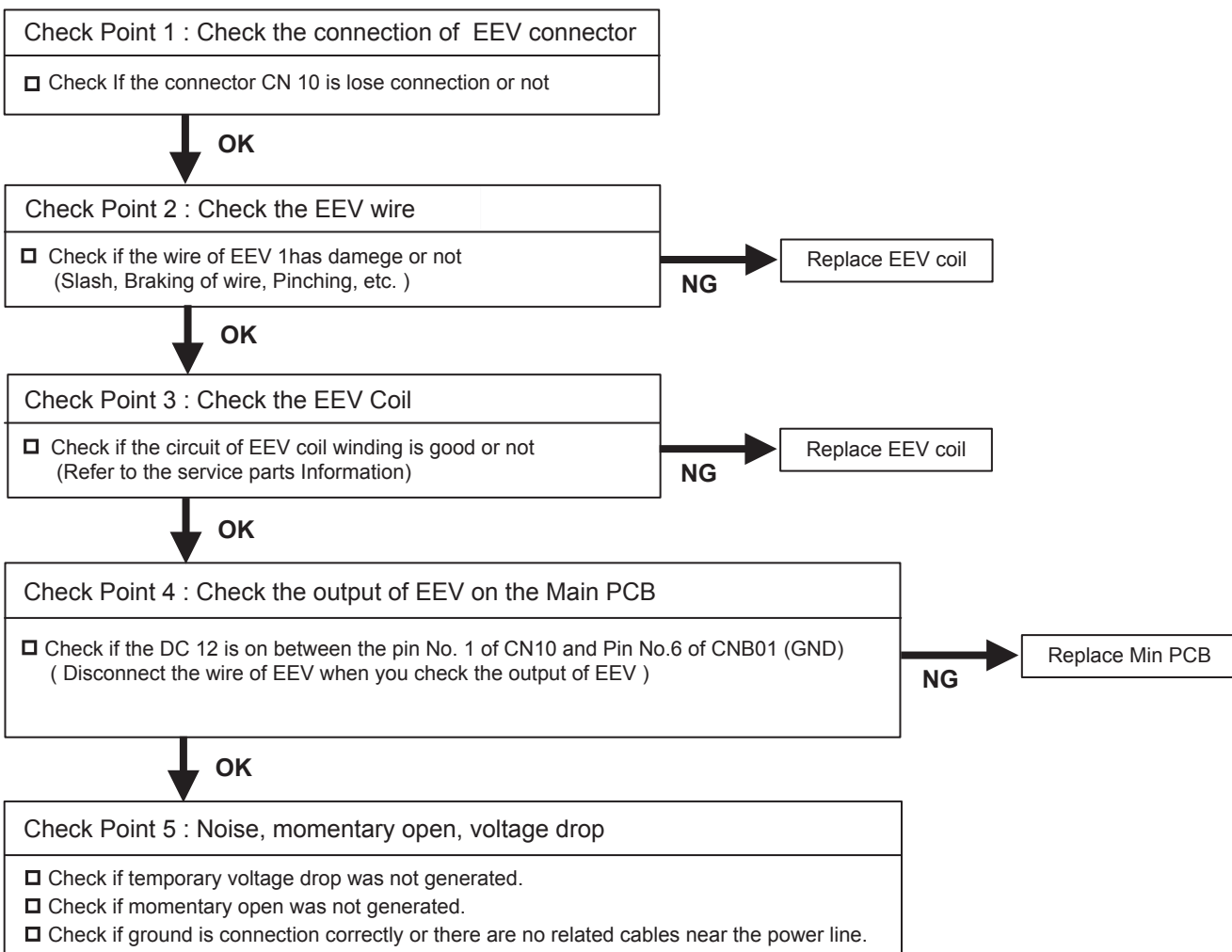

Trouble shooting 112 <u>INDOOR UNIT Error Method:</u> Damper(OPEN/CLOSE) Detection Limit Switch Error	<u>Indicate or Display:</u> Outdoor Unit : E. 5U. 1 Indoor Unit : Operation LED 5 times Flash, Timer LED 7 Times Flash, Economy LED Continuous Flash. Error Code : 57
--	--

<u>Detective Actuators:</u> Indoor unit Controller PCB Circuit Limit switch Damper	<u>Detective details:</u> When limit switch were not able to detect the close though the damper close. (Upper air flow) When limit switch were not able to detect the open though the damper open. (Upper & Lower air flow)
--	--

<u>Forecast of Cause :</u> 1. Limit switch failure 2. Shorted connector/ wire 3. Damper faulure 4. Controller PCB failure
--

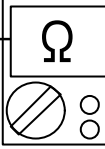
Check Point 1 : Check Limit switch <ul style="list-style-type: none"> • Check operation of limit switch. (any blocking by dust, etc.) • Remove Limit switch and check ON/OFF switching operation by using a meter. >><u>If Limit switch is detective, replace it.</u>	
--	---



Check Point 2 : Check Connector (CN18) / Wire <ul style="list-style-type: none"> • Check loose contact of CN18 /shorted wire (pinched wire). >><u>Replace Limit switch if the wire is abnormal</u>
--



Check Point 3 : Check Damper <ul style="list-style-type: none"> • Check the obstruction of damper movement. • Check the damper movement. >><u>Replace Damper if the damper is abnormal</u>



Check Point 4 : Replace Controller PCB ▶ <u>If Check Point 1~3 do not improve the symptom, change Controller PCB.</u>
--

Trouble shooting 113 <u>INDOOR UNIT Error Method:</u> Damper(OPEN/CLOSE) Simultaneous Detection Limit Switch Error	<u>Indicate or Display:</u> Outdoor Unit : E. 5U. 1 Indoor Unit : Operation LED 5 times Flash, Timer LED 7 Times Flash, Economy LED Continuous Flash. Error Code : 57
---	---

<u>Detective Actuators:</u> Indoor unit Controller PCB Circuit Limit switch	<u>Detective details:</u> When the limit switch detects open and close at the simultaneous.
---	--

<u>Forecast of Cause :</u> 1. Limit switch failure 2. Shorted connector/ wire 3. Controller PCB failure
--

Check Point 1 : Check Limit switch <ul style="list-style-type: none"> • Check operation of limit switch. (any blocking by dust, etc.) • Remove Limit switch and check ON/OFF switching operation by using a meter. >><u>If Limit switch is detective, replace it.</u>	
--	---



Check Point 2 : Check Connector (CN18) / Wire <ul style="list-style-type: none"> • Check loose contact of CN18 /shorted wire (pinched wire). >><u>Replace Limit switch if the wire is abnormal</u>
--



Check Point 3 : Replace Controller PCB ▶ <u>If Check Point 1 & 2 do not improve the symptom, change Controller PCB.</u>
--

4-3-2 Trouble Shooting With Error Code (OUTDOOR UNIT)

Trouble shooting 16 OUTDOOR UNIT Error Method : Outdoor Unit Network Communication 2 Error	Indicate or Display: Outdoor Unit : E. 14. 2 Indoor Unit : Operation LED 9 times Flash, Timer LED 15 Times Flash, Filter LED Continuous Flash. Error Code : 14
---	---

Detective Actuators: Outdoor unit Main PCB Outdoor unit communication PCB	Detective details: •No communication for 180 seconds or more from all indoor units that once received communication.
--	--

Forecast of Cause : <ol style="list-style-type: none"> 1. Noise, momentary open, voltage drop 2. Indoor unit power off 3. Communication line connection defective 4. Terminal resistor setting mistake 5. Communication PCB mounting defective, Communication PCB defective 6. Main PCB defective
--

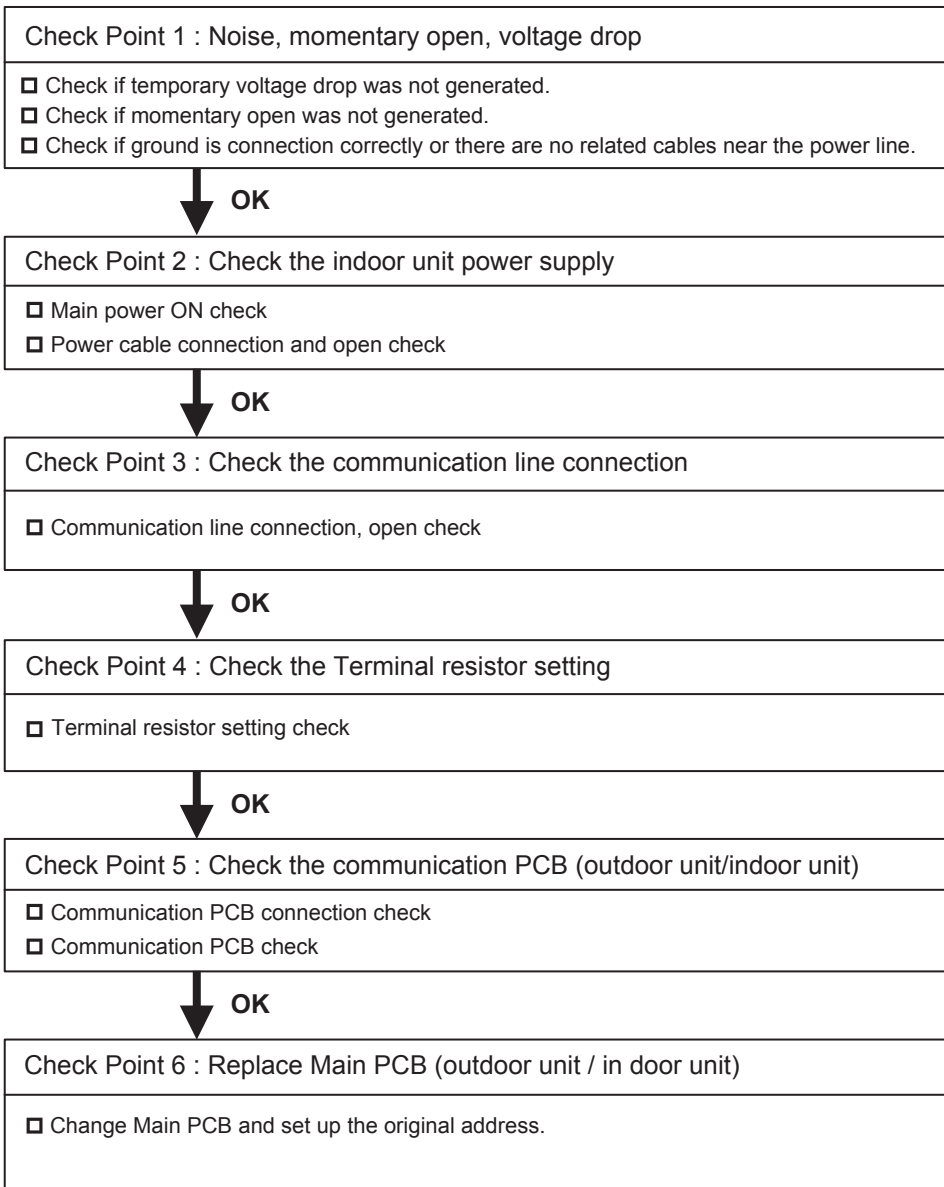

Trouble shooting 17 OUTDOOR UNIT Error Method: Outdoor Unit EEPROM Access Error	Indicate or Display: Outdoor Unit : E. 62. 3 Indoor Unit : Operation LED 9 times Flash, Timer LED 15 Times Flash, Filter LED Continuous Flash. Error Code : 62
--	---

Detective Actuators: Outdoor unit Main PCB	Detective details: • Access to EEPROM failed due to some cause after outdoor unit started.
--	--

Forecast of Cause : 1.Noise, momentary open, voltage drop 2. Main PCB defective

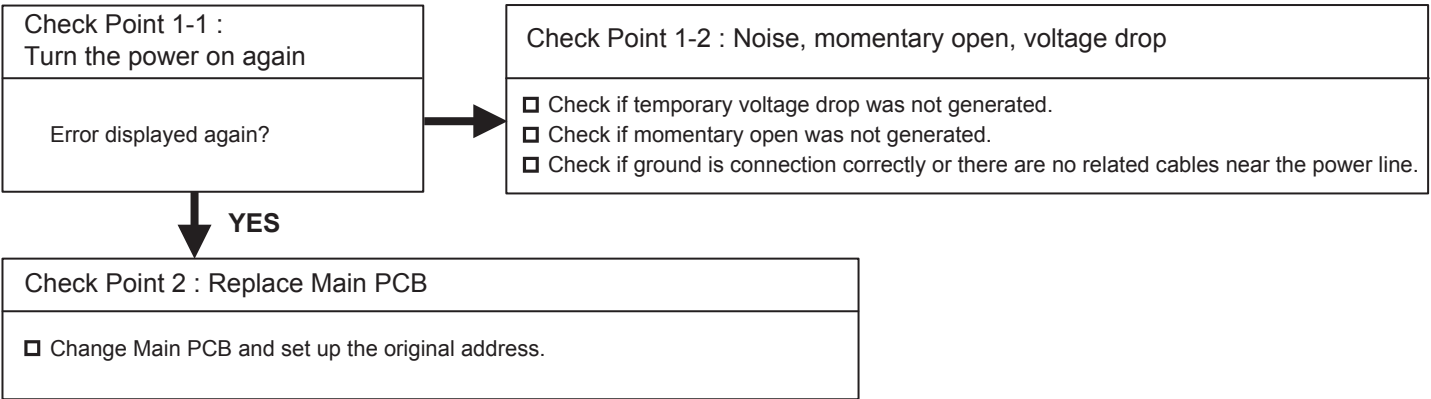

Trouble shooting 18 OUTDOOR UNIT Error Method: Inverter Communication Error	Indicate or Display: Outdoor Unit : E. 62. 6 Indoor Unit : Operation LED 9 times Flash, Timer LED 15 Times Flash, Filter LED Continuous Flash. Error Code : 62
--	---

Detective Actuators: Outdoor unit Main PCB Outdoor unit Inverter PCB	Detective details: •Communication not received from Inverter PCB for 10 seconds or more
---	---

Forecast of Cause : 1. Noise 2. Main to Inverter PCBs wiring connection defective 3. Main PCB defective 4. Inverter PCB defective

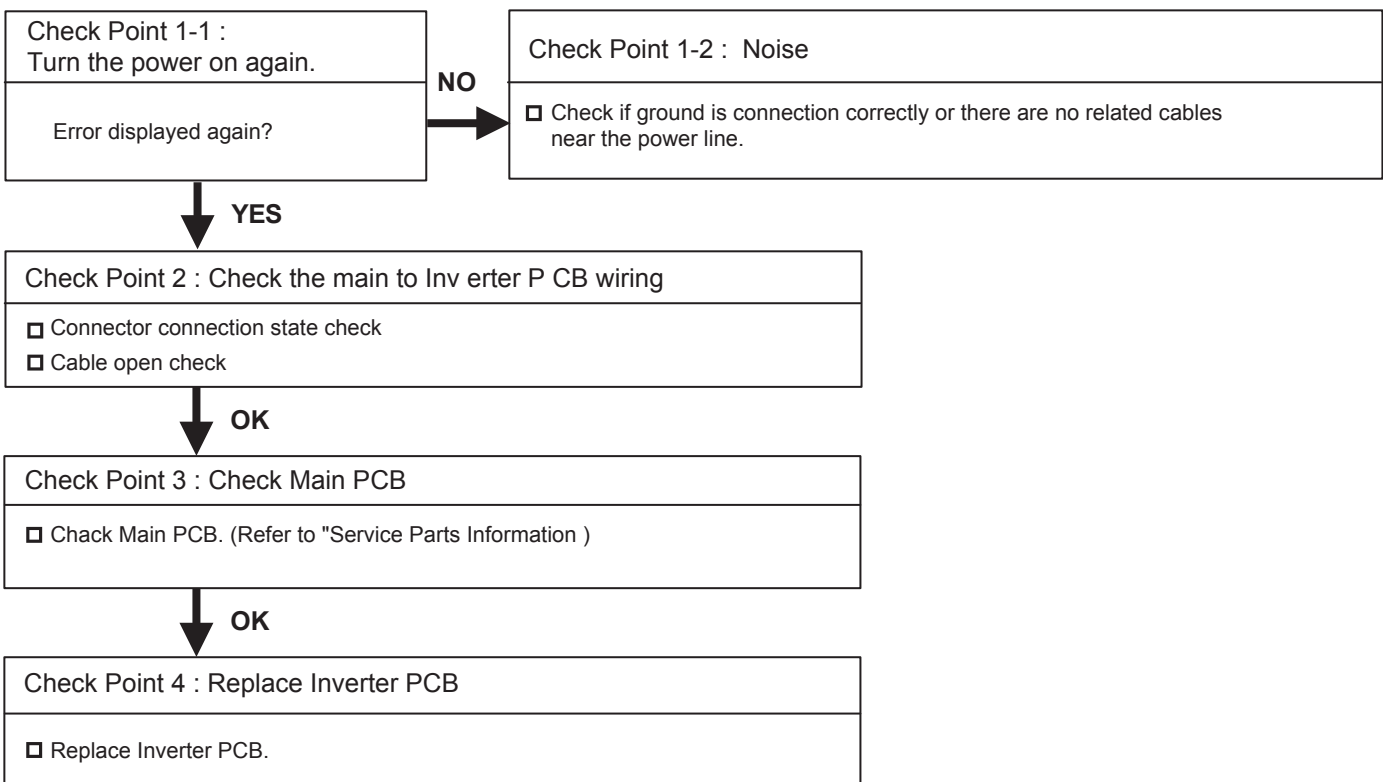

Trouble shooting 19 OUTDOOR UNIT Error Method: EEPROM Data corrupted Error	Indicate or Display: Outdoor Unit : E. 62. 8 Indoor Unit : Operation LED 9 times Flash, Timer LED 15 Times Flash, Filter LED Continuous Flash. Error Code : 62
---	---

Detective Actuators: Outdoor unit Main PCB	Detective details: <ul style="list-style-type: none"> ▪ Set contents sum value memorized in EEPROM and sum value calculated based on the set contents read from EEPROM do not match * Regarding the sum value, only the contents set in the push button SW setting mode (F2) shall be the objective.
--	--

Forecast of Cause : 1. Noise, momentary open, voltage drop 2. Main PCB defective

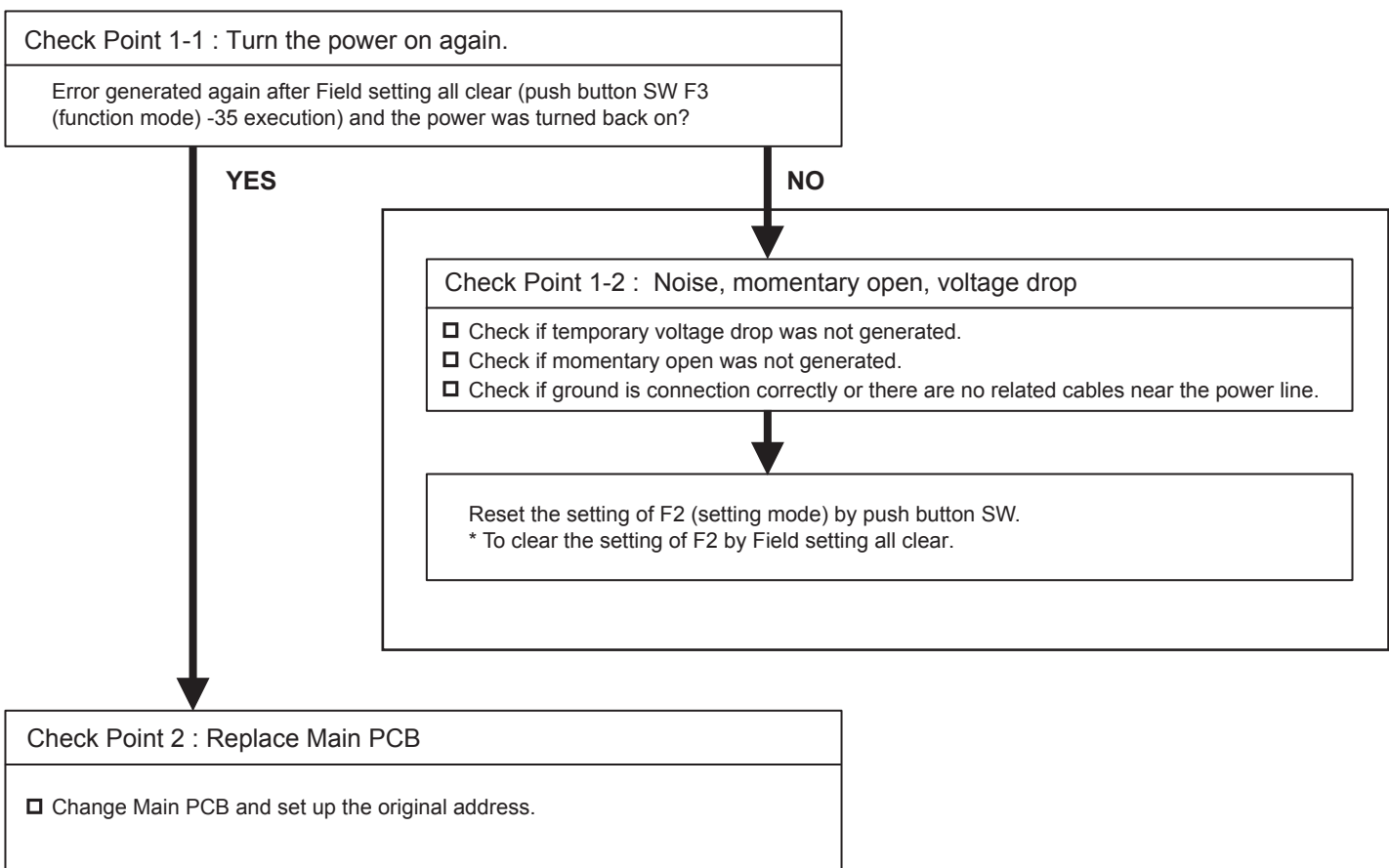

Trouble shooting 20 OUTDOOR UNIT Error Method: Inverter Error	Indicate or Display: Outdoor Unit : E. 63. 1 Indoor Unit : Operation LED 9 times Flash, Timer LED 15 Times Flash, Filter LED Continuous Flash. Error Code : 63
--	---

Detective Actuators: Inverter PCB Filter PCB	Detective details: ▪ Error information received from Inverter PCB
---	---

Forecast of Cause : <ol style="list-style-type: none"> 1.Noise, momentary open, voltage drop. 2. Power supply to Filter PCB (INV) to Inverter PCB wiring disconnection, open 3. Filter PCB (INV) defective 4. Inverter PCB defective
--

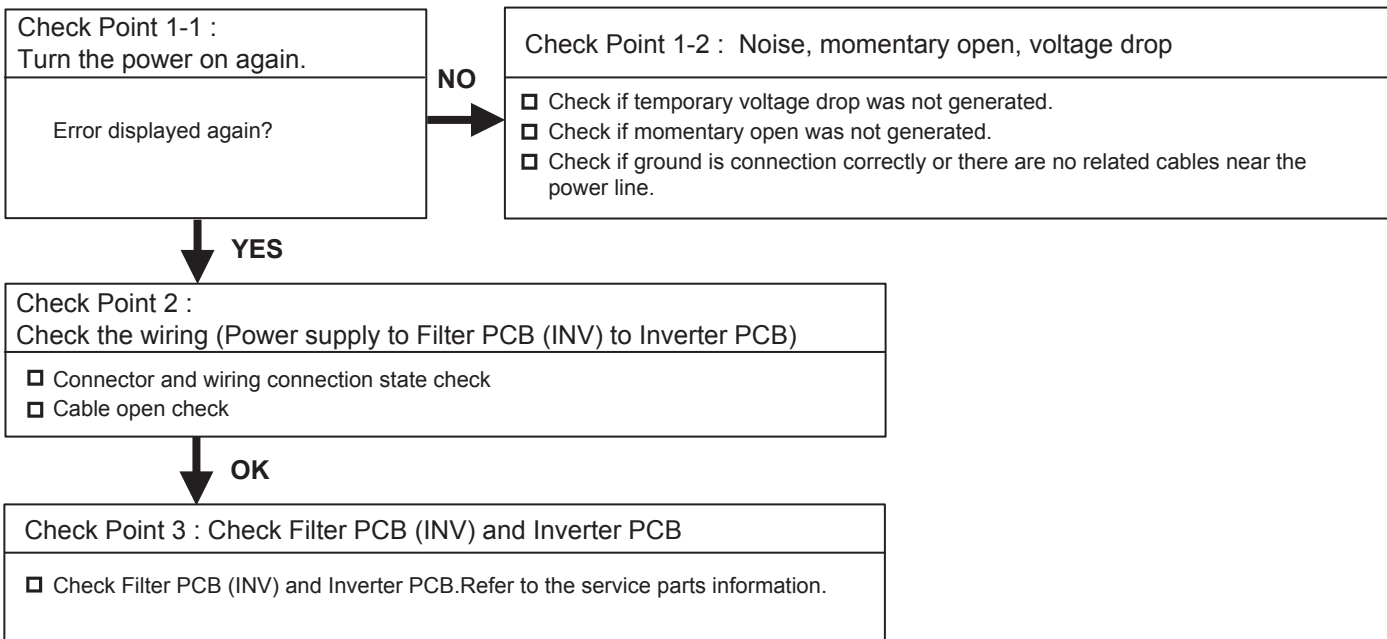

Trouble shooting 21 OUTDOOR UNIT Error Method: Inverter PCB short interruption detection	Indicate or Display: Outdoor Unit : E. 67. 2 Indoor Unit : No Display Error Code : 67
---	--

Detective Actuators: Inverter PCB	Detective details: · "Momentary power failure" received from Inverter PCB
---	---

Forecast of Cause : <ol style="list-style-type: none"> 1. Noise, momentary power failure, voltage drop 2. Power supply to Filter PCB (INV) to Inverter PCB wiring disconnection, open 3. Main PCB defective 4. Inverter PCB defective
--

Check Point 1 : Noise, momentary power failure, voltage drop
<input type="checkbox"/> Check if temporary voltage drop was not generated. <input type="checkbox"/> Check if momentary power failure was not generated. <input type="checkbox"/> Check if ground is connection correctly or there are no related cables near the power line.



Check Point 2 : Check the wiring (Power supply to Filter PCB (INV) to Inverter PCB)
<input type="checkbox"/> Connector and wiring connection state check <input type="checkbox"/> Cable open check



Check Point 3 : Check Main PCB
<input type="checkbox"/> Check Main PCB Power supply



Check Point 4 : Replace Inverter PCB
<input type="checkbox"/> Replace Inverter PCB.

Trouble shooting 22 OUTDOOR UNIT Error Method: Outdoor Unit transmission PCB Parallel Communication Error	Indicate or Display: Outdoor Unit : E. 69. 1 Indoor Unit : Operation LED 9 times Flash, Timer LED 15 Times Flash, Filter LED Continuous Flash. Error Code : 69
--	---

Detective Actuators: Outdoor unit Main PCB Communication PCB	Detective details: <ul style="list-style-type: none"> Parallel communication (communication between main CPU and communication PCB) failed 5 times.
---	---

Forecast of Cause : <ul style="list-style-type: none"> 1. Noise 2. Communication PCB connection defective 3. Communication PCB defective 4. Main PCB defective

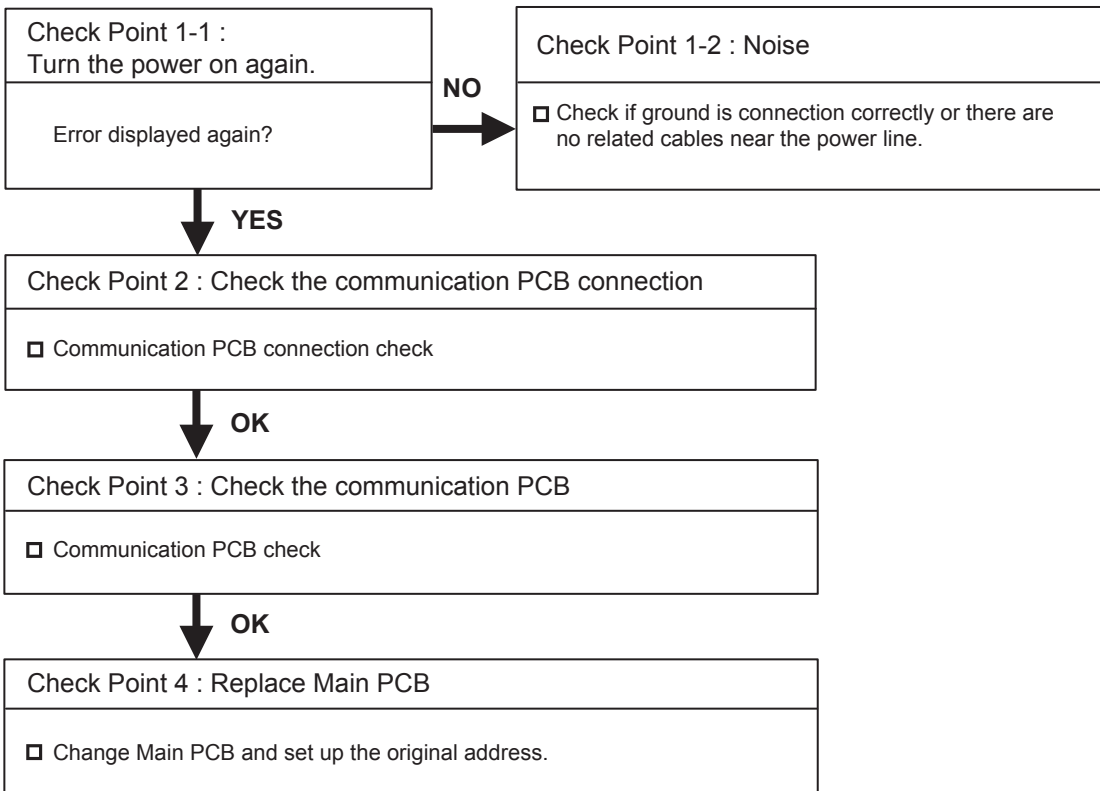

Trouble shooting 23 OUTDOOR UNIT Error Method: Discharge Temp Sensor Error	Indicate or Display: Outdoor Unit : E. 71. 1 Indoor Unit : Operation LED 9 times Flash, Timer LED 15 Times Flash, Filter LED Continuous Flash. Error Code : 71
---	---

Detective Actuators: Discharge temperature thermistor 1	Detective details: <ul style="list-style-type: none"> • Discharge temperature thermistor 1 short detected • Discharge thermistor 1 open detected after compressor 1 operated continuously for 5 minutes or more
---	---

Forecast of Cause :	1. Connector connection defective, open 2. Thermistor defective 3. Main PCB defective
----------------------------	---

Check Point 1 : Check the connector connection and cable open
<input type="checkbox"/> Connector connection state check <input type="checkbox"/> Cable open check



Check Point 2 : Check the thermistor
<input type="checkbox"/> Thermistor characteristics check (Disconnect the thermistor from the PCB and check.) * For the thermistor characteristics, refer to the "Service Parts Information 22".



Check Point 3 : Check voltage of Main PCB (DC5.0V)
<input type="checkbox"/> Main PCB (CN141:1-2) voltage value = 5V <u>Remove the thermistor from Main PCB, check the voltage.</u>

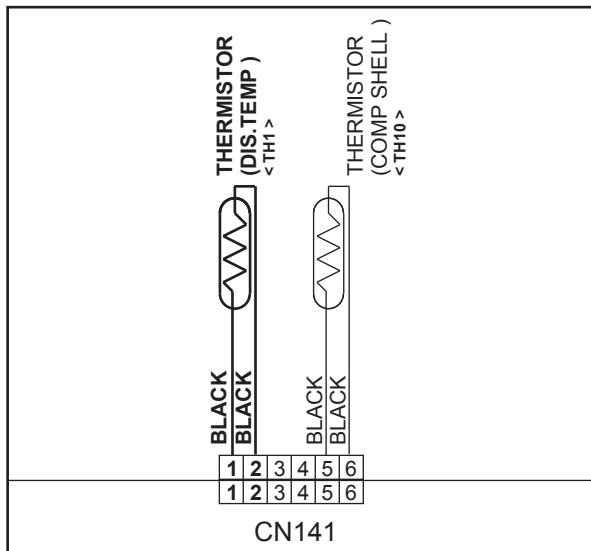

Discharge temperature sensor 1 (CN141:1-2)

► **If the voltage does not appear, replace Main PCB and set up original address.**

Trouble shooting 24 OUTDOOR UNIT Error Method: Compressor Temp Sensor Error	Indicate or Display: Outdoor Unit : E. 72. 1 Indoor Unit : Operation LED 9 times Flash, Timer LED 15 Times Flash, Filter LED Continuous Flash. Error Code : 72
--	---

Detective Actuators: Compressor temperature thermistor	Detective details: <ul style="list-style-type: none"> • Compressor temperature thermistor short detected • Compressor thermistor open detected after compressor operated continuously for 5 minutes or more
--	--

Forecast of Cause :	1. Connector connection defective, open 2. Thermistor defective 3. Main PCB defective
----------------------------	---

Check Point 1 : Check the connector connection and cable open
<input type="checkbox"/> Connector connection state check <input type="checkbox"/> Cable open check



Check Point 2 : Check the thermistor
<input type="checkbox"/> Thermistor characteristics check (Disconnect the thermistor from the PCB and check.) * For the thermistor characteristics, refer to the "Service Parts Information".



Check Point 3 : Check voltage of Main PCB (DC5.0V)
--

- Main PCB (CN141:5-6) voltage value = 5V
Remove the thermistor from Main PCB, check the voltage.

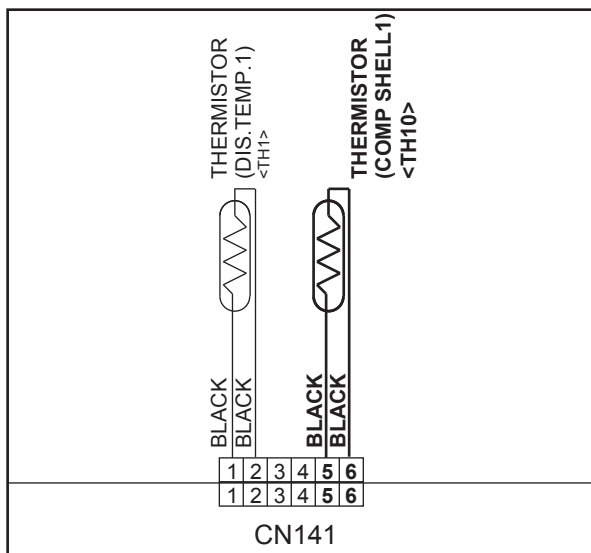

Compressor temperature sensor (CN141:5-6)

▶ **If the voltage does not appear, replace Main PCB and set up original address.**

Trouble shooting 25 OUTDOOR UNIT Error Method: Outdoor Unit Heat Ex. Liquid Temp. Sensor Error	Indicate or Display: Outdoor Unit : E. 73. 3 Indoor Unit : Operation LED 9 times Flash, Timer LED 15 Times Flash, Filter LED Continuous Flash. Error Code : 73
---	---

Detective Actuators: Heat exchanger liquid temperature thermistor	Detective details: • Heat exchanger liquid temperature thermistor short or open detected
---	--

Forecast of Cause : <ol style="list-style-type: none"> 1. Connector connection defective, open 2. Thermistor defective 3. Main PCB defective
--

Check Point 1 : Check the connector connection and cable open
<input type="checkbox"/> Connector connection state check <input type="checkbox"/> Cable open check



Check Point 2 : Check the thermistor
<input type="checkbox"/> Thermistor characteristics check (Disconnect the thermistor from the PCB and check.) * For the thermistor characteristics, refer to the "Service Parts Information 22".

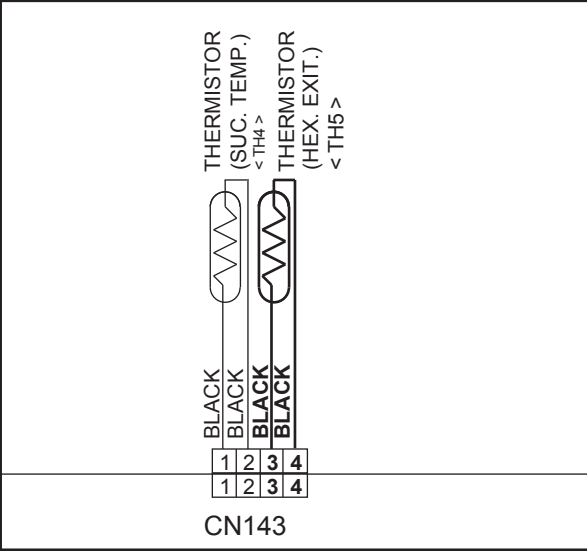

Check Point 3 : Check voltage of Main PCB (DC5.0V)	
<input type="checkbox"/> Main PCB (CN143:3-4) voltage value = 5V <u>Remove the thermistor from Main PCB, check the voltage.</u>	
	
Heat exchanger liquid temperature sensor (CN143:3-4)	
▶ <u>If the voltage does not appear, replace Main PCB and set up original address.</u>	

Trouble shooting 26 OUTDOOR UNIT Error Method: Outdoor Temp Sensor Error	Indicate or Display: Outdoor Unit : E. 74. 1 Indoor Unit : Operation LED 9 times Flash, Timer LED 15 Times Flash, Filter LED Continuous Flash. Error Code : 74
---	---

Detective Actuators: Outdoor temperature thermistor	Detective details: • Outdoor temperature thermistor short or open detected
---	--

Forecast of Cause : <ol style="list-style-type: none"> 1. Connector connection defective, open 2. Thermistor defective 3. Main PCB defective
--

Check Point 1 : Check the connector connection and cable open
<input type="checkbox"/> Connector connection state check <input type="checkbox"/> Cable open check



Check Point 2: Check the thermistor
<input type="checkbox"/> Thermistor characteristics check (Disconnect the thermistor from the PCB and check.) * For the thermistor characteristics, refer to the "Service Parts Information ".



Check Point 3 : Check voltage of Main PCB (DC5.0V)
--

- Main PCB (CN144:1-3) voltage value = 5V
Remove the thermistor from Main PCB, check the voltage.

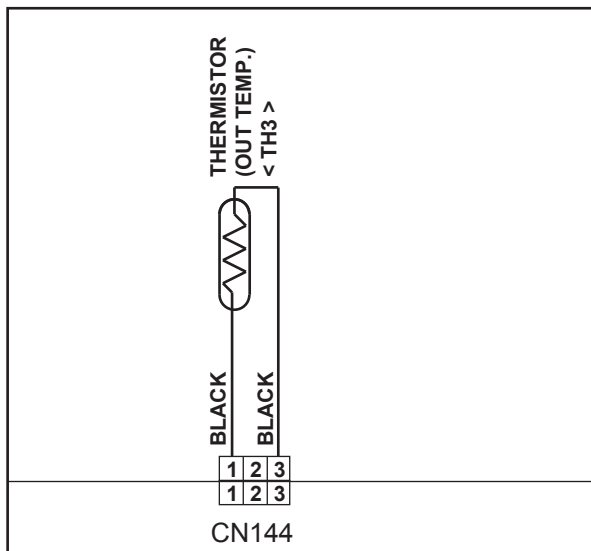

Outdoor temperature sensor (CN144:1-3)

► **If the voltage does not appear, replace Main PCB and set up original address.**

Trouble shooting 27 OUTDOOR UNIT Error Method: Suction Gas Temp Sensor Error	Indicate or Display: Outdoor Unit : E. 75. 1 Indoor Unit : Operation LED 9 times Flash, Timer LED 15 Times Flash, Filter LED Continuous Flash. Error Code : 75
---	---

Detective Actuators: Suction gas temperature thermistor	Detective details: • Suction gas temperature thermistor short or open detected
---	--

Forecast of Cause : <ol style="list-style-type: none"> 1. Connector connection defective, open 2. Thermistor defective 3. Main PCB defective
--

Check Point 1 : Check the connector connection and cable open
<input type="checkbox"/> Connector connection state check <input type="checkbox"/> Cable open check



Check Point 2 : Check the thermistor
<input type="checkbox"/> Thermistor characteristics check (Disconnect the thermistor from the PCB and check.) * For the thermistor characteristics, refer to the "Service Parts Information".



Check Point 3 : Check voltage of Main PCB (DC5.0V)
--

- Main PCB (CN143:1-2) voltage value = 5V
Remove the thermistor from Main PCB, check the voltage.

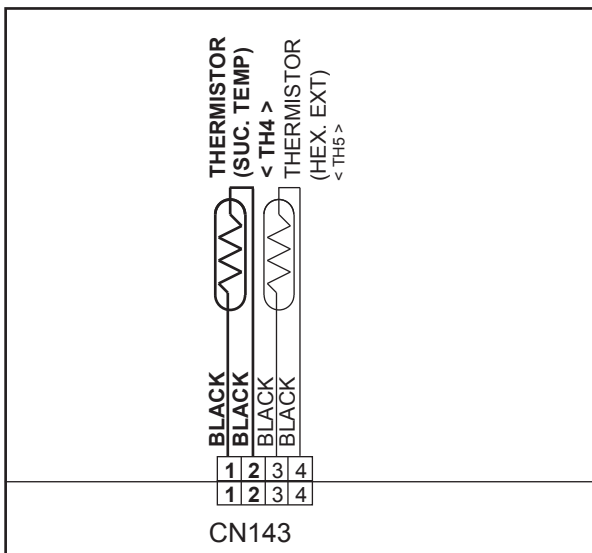

Suction gas temperature sensor (CN143:1-2)

► **If the voltage does not appear, replace Main PCB and set up original address.**

<p>Trouble shooting 28 <u>OUTDOOR UNIT Error Method:</u> Heat Sink Temp Sensor Error</p>	<p><u>Indicate or Display:</u> Outdoor Unit : E. 77. 1 Indoor Unit : Operation LED 9 times Flash, Timer LED 15 Times Flash, Filter LED Continuous Flash. Error Code : 77</p>
---	---

<p><u>Detective Actuators:</u> Inverter PCB</p>	<p><u>Detective details:</u> • Heat sink temperature thermistor (Inside IPM) open/short circuit detected</p>
--	---

<p><u>Forecast of Cause :</u> 1.Inverter PCB failure ▶ <u>If this error is displayed, replace Inverter PCB</u></p>

Trouble shooting 29 OUTDOOR UNIT Error Method: Current Sensor Error	Indicate or Display: Outdoor Unit : E. 84. 1 Indoor Unit : Operation LED 9 times Flash, Timer LED 15 Times Flash, Filter LED Continuous Flash. Error Code : 84
--	---

Detective Actuators: Judgment from value sensed by current sensor 1 (current sensor for inverter) * Current sensor 1 is mounted on Filter PCB (INV)	Detective details: <ul style="list-style-type: none"> • "Protection stop by "inverter speed ≥ 20rps and sensor value 0A continued for 1 min"" was generated 2 times • Sensor value while inverter stopped = maximum was detected
--	---

Forecast of Cause : <ol style="list-style-type: none"> 1. Filter PCB to Inverter PCB current sensor wiring connector disconnection, open 2. Power supply to Filter PCB to Inverter PC wiring disconnection, open 3. Filter PCB defective (Power supply section, current sensor section) 4. Inverter PCB defective
--

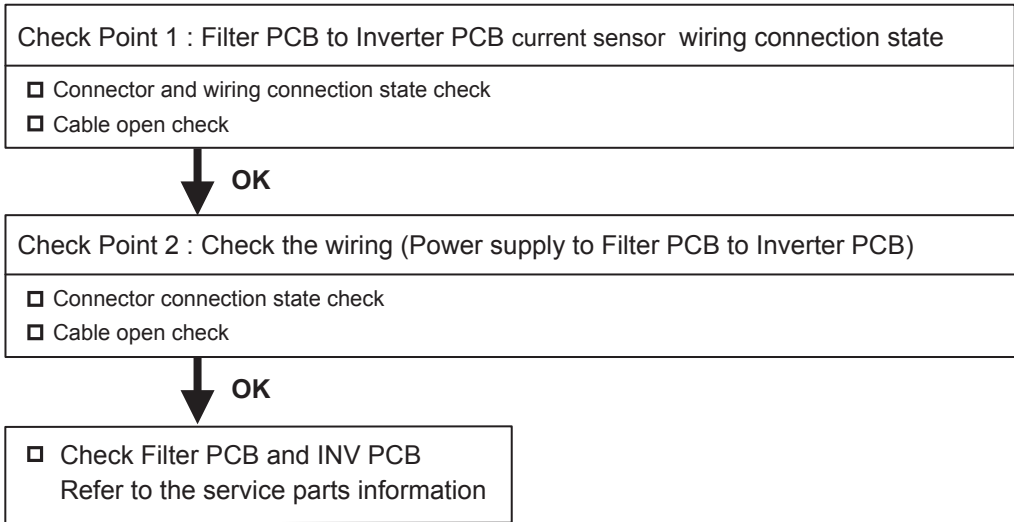

Trouble shooting 30 OUTDOOR UNIT Error Method: Discharge Pressure Sensor Error	Indicate or Display: Outdoor Unit : E. 86. 1 Indoor Unit : Operation LED 9 times Flash, Timer LED 15 Times Flash, Filter LED Continuous Flash. Error Code : 86
---	---

Detective Actuators: Discharge pressure sensor	Detective details: • When any of the following conditions is satisfied, a discharge pressure sensor error is generated. <ol style="list-style-type: none"> 1. 30 seconds or more have elapsed since the outdoor unit power was turned on and pressure sensor detected value < 0.3V continued for 30 seconds or more 2. 30 seconds or more have elapsed since the outdoor unit power was turned on and pressure sensor detected value \geq 5.0V was detected.
--	--

Forecast of Cause : <ol style="list-style-type: none"> 1. Discharge pressure sensor connector disconnection, open 2. Discharge pressure sensor defective 3. Main PCB defective
--

Check Point 1 : Check the discharge pressure sensor connection state

- Connector connection state check
- Cable open check

↓
OK

Check Point 2 : Check the discharge pressure sensor

- Sensor characteristics check
 * For the characteristics of the discharge pressure sensor, refer to the "Service Parts Information".

↓
OK

Check Point 3 : Check voltage of Main PCB (DC5.0V)

- Main PCB (CN118:1-3) voltage value = 5V
 Remove the thermistor from Main PCB, check the voltage.



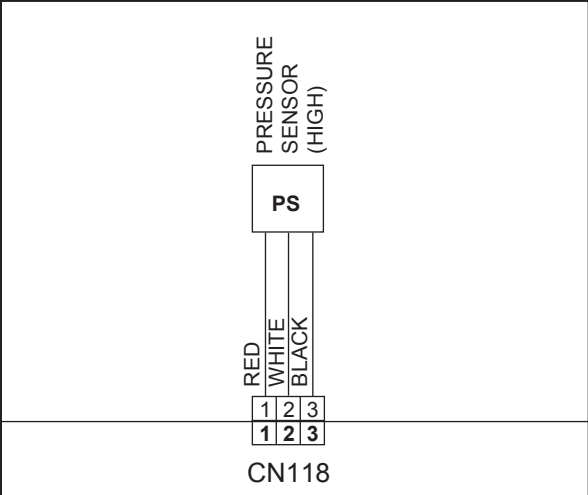

Discharge pressure sensor (CN118:1-3)

► **If the voltage does not appear, replace Main PCB and set up original address.**

Trouble shooting 31 OUTDOOR UNIT Error Method: Suction Pressure Sensor Error	Indicate or Display: Outdoor Unit : E. 86. 3 Indoor Unit : Operation LED 9 times Flash, Timer LED 15 Times Flash, Filter LED Continuous Flash. Error Code : 86
---	---

Detective Actuators: Suction pressure sensor	Detective details: <ul style="list-style-type: none"> • When any of the following conditions is satisfied, a suction pressure sensor error is generated. <ol style="list-style-type: none"> 1. 30 seconds or more have elapsed since the outdoor unit power was turned on and pressure sensor detected value < 0.06V continued for 30 seconds or more. 2. 30 seconds or more have elapsed since the outdoor unit power was turned on and pressure sensor detected value \geq 5.0V was detected.
--	--

Forecast of Cause : <ol style="list-style-type: none"> 1. Suction pressure sensor connector disconnection, open 2. Suction pressure sensor defective 3. Main PCB defective
--

Check Point 1 : Check the suction pressure sensor connection state
<input type="checkbox"/> Connector connection state check <input type="checkbox"/> Cable open check

↓
OK

Check Point 2 : Check the suction pressure sensor
<input type="checkbox"/> Sensor characteristics check * For the characteristics of the suction pressure sensor, refer to the "Service Parts Information".

↓
OK

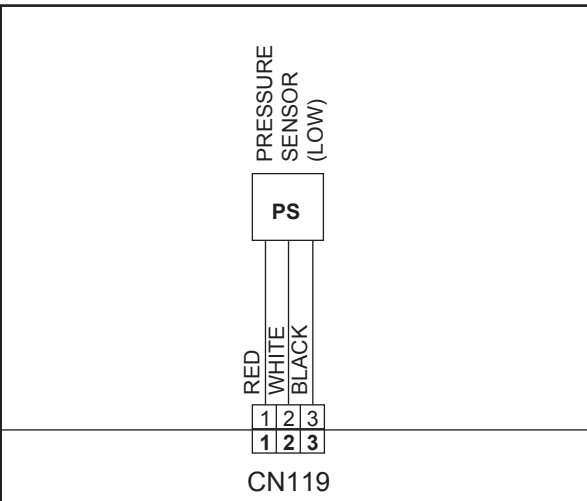
Check Point 3 : Check voltage of Main PCB (DC5.0V)	
<input type="checkbox"/> Main PCB (CN119:1-3) voltage value = 5V <u>Remove the thermistor from Main PCB, check the voltage.</u>	
	
Suction pressure sensor (CN119:1-3)	
► If the voltage does not appear, replace Main PCB and set up original address.	

Trouble shooting 32 OUTDOOR UNIT Error Method: Inverter Compressor Start UP Error	Indicate or Display: Outdoor Unit : E. 93. 1 Indoor Unit : Operation LED 9 times Flash, Timer LED 15 Times Flash, Filter LED Continuous Flash. Error Code : 93
--	---

<u>Detective Actuators:</u> Inverter PCB Inverter Compressor	<u>Detective details:</u> <ul style="list-style-type: none"> ▪ "Protection stop by "overcurrent generation at inverter compressor starting" ⇒ restart" generated consecutively 60 times x 2 sets (total 120 times) * The shortest time up to error generation is about 100 minutes *Restart is not performed if an indoor unit in the same refrigerant system is not turned ON by thermostat. * After the end of the 1st set, the 2nd set is not started if all the compressors in the same refrigerant system are not temporarily stopped.
---	--

<u>Forecast of Cause :</u> <ol style="list-style-type: none"> 1. Inverter PCB to inverter compressor wiring disconnection, open 2. Inverter PCB defective 3. Inverter compressor defective (lock, winding short)
--

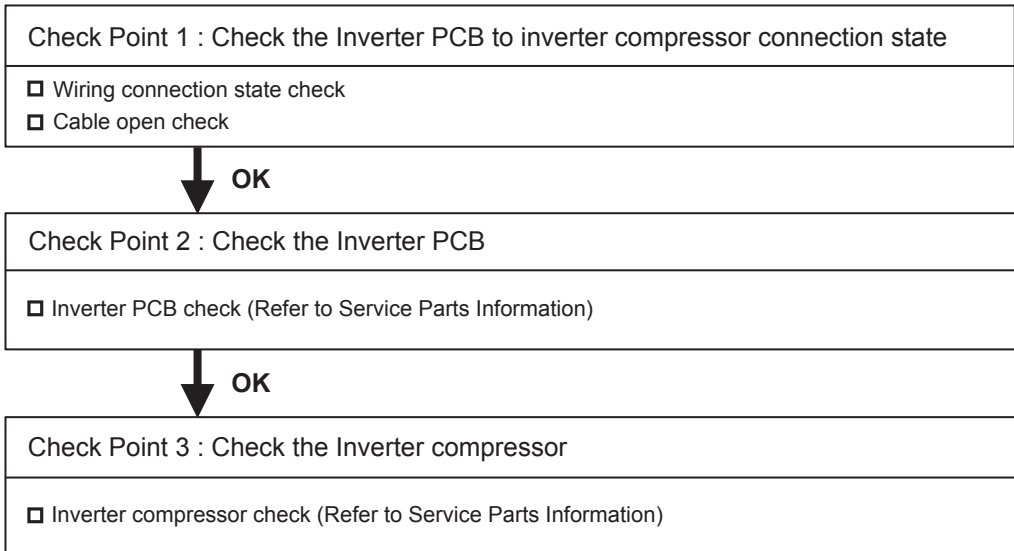

Trouble shooting 33 OUTDOOR UNIT Error Method: Trip Detection	Indicate or Display: Outdoor Unit : E. 94. 1 Indoor Unit : Operation LED 9 times Flash, Timer LED 15 Times Flash, Filter LED Continuous Flash. Error Code : 94
--	---

Detective Actuators: Inverter PCB Inverter Compressor SV coil	Detective details: <ul style="list-style-type: none"> ▪ "Protection stop by "overcurrent generation after inverter compressor start processing completed"" generated consecutively 5 times. * The number of generations is reset if protection stop is not generated again within 40 seconds after restarting.
---	--

Forecast of Cause :	<ol style="list-style-type: none"> 1. Outdoor unit fan operation defective, foreign matter on hear exchanger, excessive rise of ambient temperature 2. Inverter PCB defective 3. Inverter compressor defective (lock, winding short) 4. SV Coil Abnormal
----------------------------	--

Check Point 1 : Check the outdoor unit fan operation, heat exchanger, ambient temperature
<input type="checkbox"/> No obstructions in air passages? <input type="checkbox"/> Heat exchange fins clogged <input type="checkbox"/> Outdoor unit fan motor check <input type="checkbox"/> Ambient temperature not raised by the effect of other heat sources? <input type="checkbox"/> Discharged air not sucked in?



Check Point 2 : Check the Inverter PCB
<input type="checkbox"/> Inverter PCB check (Refer to Service Parts Information)



Check Point 3 : Check the Inverter compressor
<input type="checkbox"/> Check Inverter compressor (Refer to Service Parts Information)



Check Point 4: Check the SV, Coil
<input type="checkbox"/> Check the connector of SV connected on the Main PCB surely. <input type="checkbox"/> Check the Coil installed on the Valve surely (Fixed condition, direction, depth) <input type="checkbox"/> Check the resistance of wires (Not open circuit) <input type="checkbox"/> Check the valve are operating surely

Trouble shooting 34 OUTDOOR UNIT Error Method: Compressor Motor Loss of Synchronization	Indicate or Display: Outdoor Unit : E. 95. 5 Indoor Unit : Operation LED 9 times Flash, Timer LED 15 Times Flash, Filter LED Continuous Flash. Error Code : 95
--	---

Detective Actuators: Inverter PCB Inverter Compressor	Detective details: <ul style="list-style-type: none"> ▪ "Protection stop by "loss of synchronization detection"" generated consecutively 5 times *The number of generations is reset if protection stop is not generated again within 40 seconds after restarting.
--	--

Forecast of Cause : <ol style="list-style-type: none"> 1.Inverter PCB defective 2.Inverter compressor defective (lock)

Check Point 1 : Check the Inverter PCB
<input type="checkbox"/> Inverter PCB check (Refer to Service Parts Information)



Check Point 2 : Check the Inverter compressor
<input type="checkbox"/> Inverter compressor check (Refer to Service Parts Information)

Trouble shooting 35 OUTDOOR UNIT Error Method: Outdoor Unit Fan Motor Lock Error - Start up Error -	Indicate or Display: Outdoor Unit : E. 97. 1 Indoor Unit : Operation LED 9 times Flash, Timer LED 15 Times Flash, Filter LED Continuous Flash. Error Code : 97
--	---

Detective Actuators: Outdoor unit fan	Detective details: <ul style="list-style-type: none"> ▪ "Protection stop by "fan speed \leq 100rpm" 20 seconds after fan operation command issued" was generated consecutively 15 times * The compressor is protection stopped every time fan protection stop has been generated 3 times.
---	--

Forecast of Cause : <ol style="list-style-type: none"> 1. Rotation obstruction by foreign matter 2. Motor wiring, connector disconnection, open 3. Fan motor defective (winding open, lock) 4. Main PCB defective (drive circuit, speed detection circuit)

Check Point 1 : Fan rotation state check
<input type="checkbox"/> Check for the absence of foreign matter around the fan



Check Point 2 : Check the motor wiring, connector disconnection, open
<input type="checkbox"/> Check for motor wiring connector disconnection, open.



Check Point 3 : Fan motor defective
<input type="checkbox"/> Check if fan can be rotated by hand. <input type="checkbox"/> Motor winding resistance check <input type="checkbox"/> Motor operation check



Check Point 4 : Check Main PCB
<input type="checkbox"/> Drive circuit output check (Between Pin No.3 and Pin No.2 on CN 116 : DC 13.6 - 16.5 V) <input type="checkbox"/> Check if speed can be detected. <u>>>If replace Main PCB and and set up original address.</u>

Trouble shooting 36 OUTDOOR UNIT Error Method: Outdoor unit Fan motor undervoltage - Lack of DC Voltage -	Indicate or Display: Outdoor Unit : E. 97. 4 Indoor Unit : Operation LED 9 times Flash, Timer LED 15 Times Flash, Filter LED Continuous Flash. Error Code : 97
--	---

Detective Actuators: Outdoor unit main PCB	Detective details: <ul style="list-style-type: none"> ▪ Low DC power supply (DC voltage 180V or less) detected
--	---

Forecast of Cause : <ol style="list-style-type: none"> 1. Power OFF, voltage drop, momentary open 2. Power supply wiring connection defective, open 3. Main PCB defective (electrolytic capacitor, DC voltage detection circuit)
--

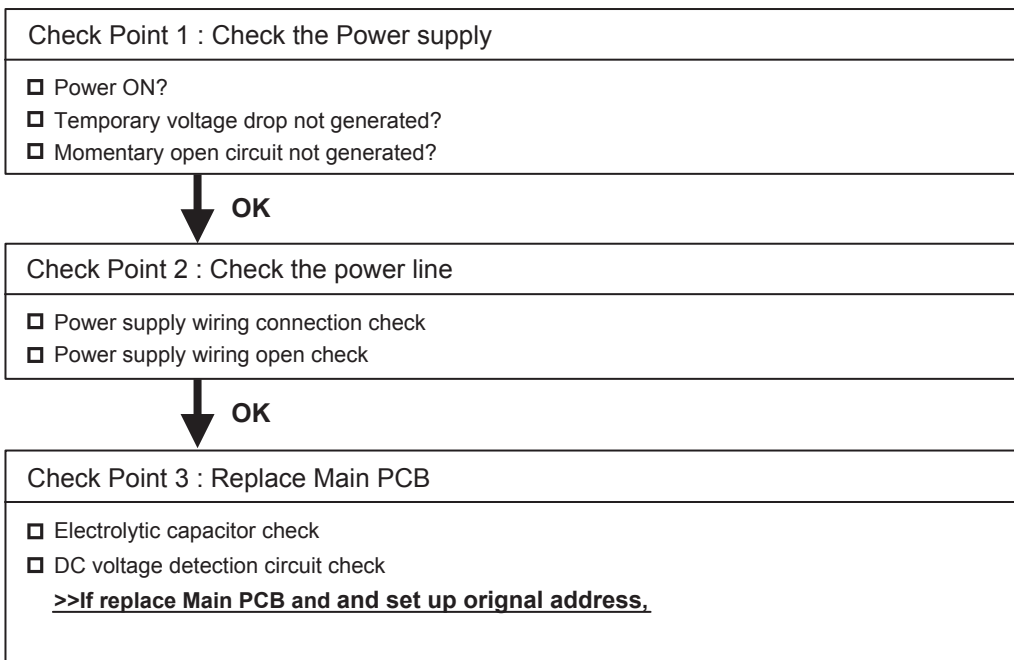

Trouble shooting 37 OUTDOOR UNIT Error Method: Outdoor Unit Fan Motor 1 Temp. Abnormal	Indicate or Display: Outdoor Unit : E. 97. 5 Indoor Unit : Operation LED 9 times Flash, Timer LED 15 Times Flash, Filter LED Continuous Flash. Error Code : 97
---	---

Detective Actuators: Outdoor unit fan	Detective details: ▪ Protection stop by speed $\leq 220\text{rpm}$ after 60 seconds have elapsed after fan operation command issued generated 3 times within 3 hours.
---	---

Forecast of Cause : <ol style="list-style-type: none"> 1. Rotation obstructed by foreign matter 2. Ventilation obstructed by heat exchange foreign matter 3. Excessive ambient temperature rise 4. Static pressure setting incorrect, specified static pressure value exceeded 5. Fan motor defective (internal PCB defective)
--

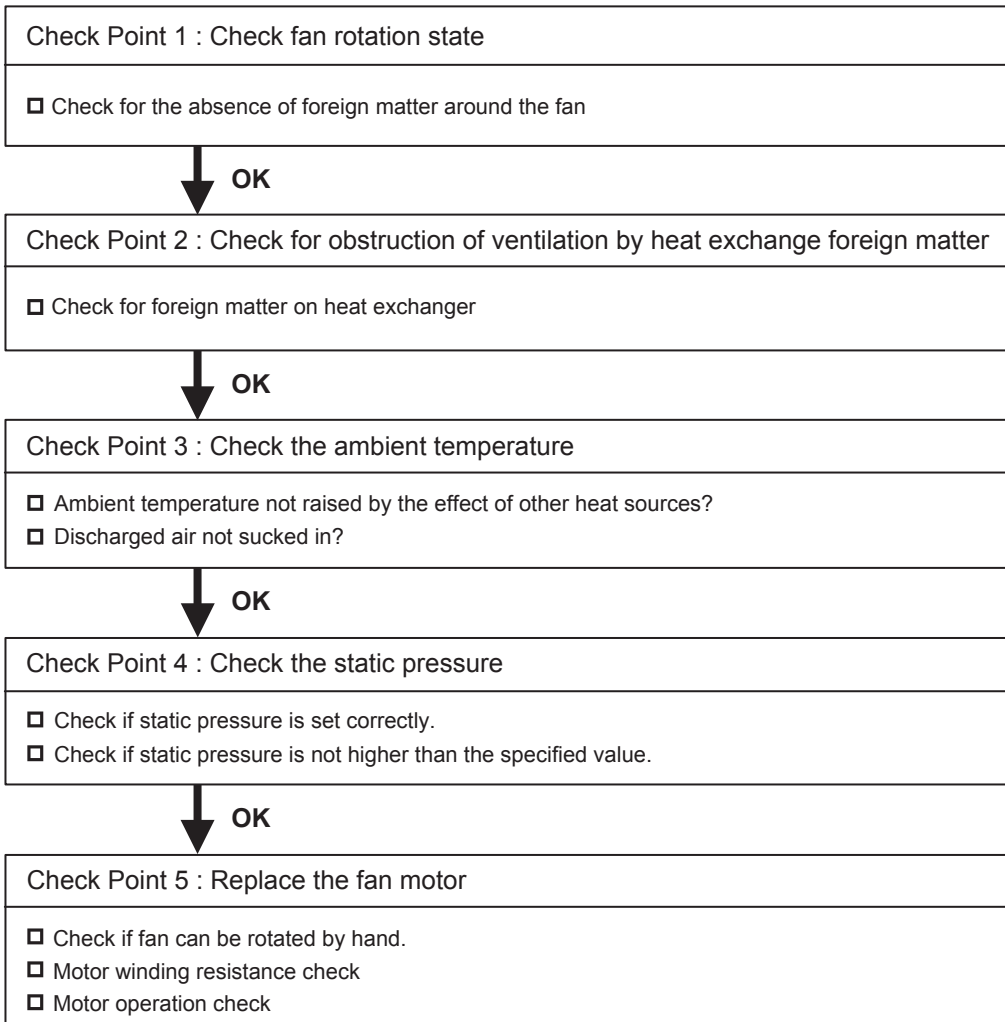

Trouble shooting 38 OUTDOOR UNIT Error Method: Coil EEV Error	Indicate or Display: Outdoor Unit : E. 9A. 1 Indoor Unit : Operation LED 9 times Flash, Timer LED 15 Times Flash, Filter LED Continuous Flash. Error Code : 9A
---	---

Detective Actuators: Outdoor unit main PCB	Detective details: ▪ When the EEV input on the Main PCB (CN116, CN117) was open circuit or short circuit.
--	---

Forecast of Cause :	1. EEV coil lose connection 2. EEV wire(s) cut or pinched 3. Defective EEV coil 4. Main PCB (DC 12V) output abnormal
----------------------------	---

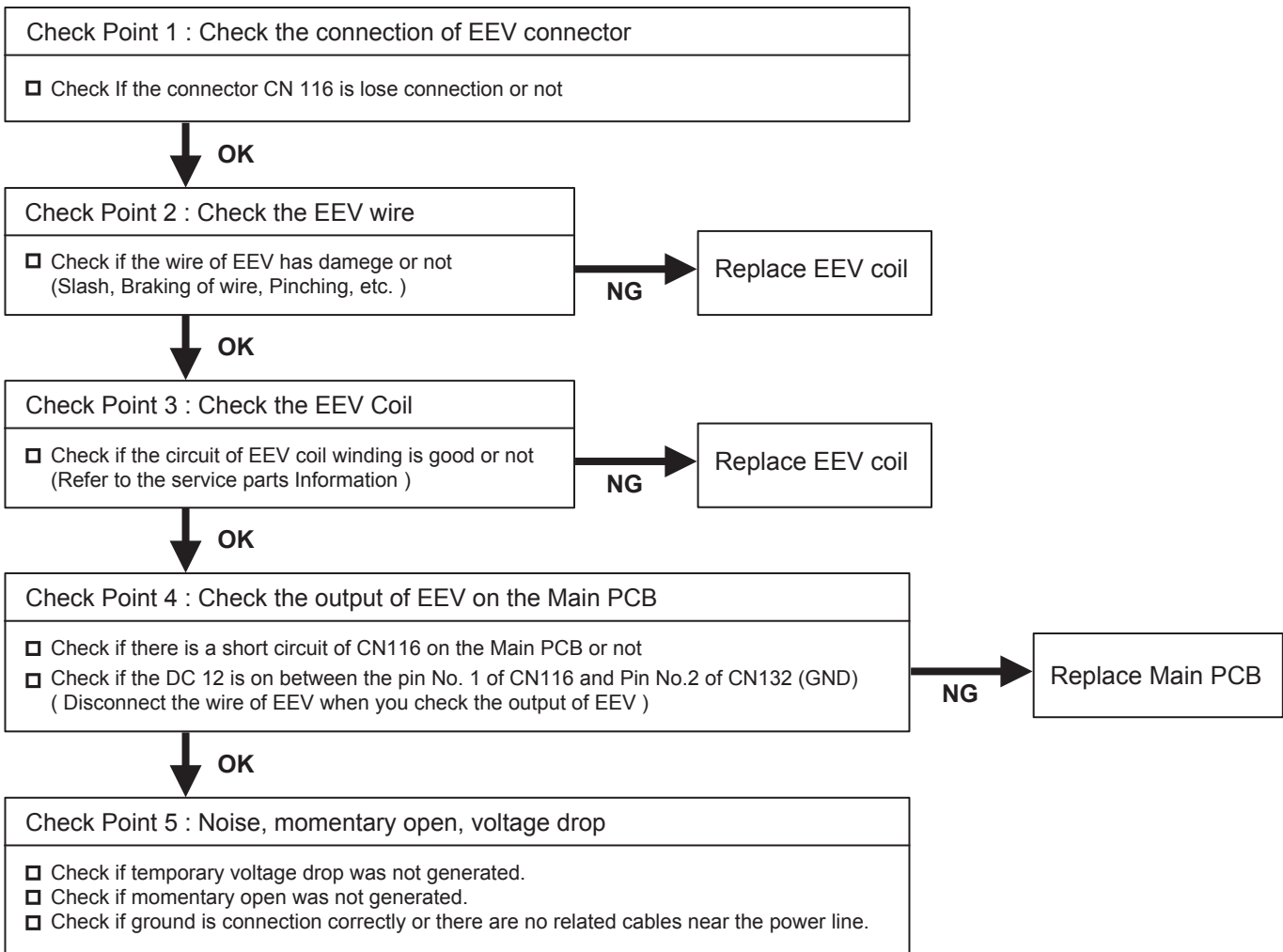

Trouble shooting 39 OUTDOOR UNIT Error Method: Discharge Temperature Abnormal	Indicate or Display: Outdoor Unit : E. A1. 1 Indoor Unit : Operation LED 9 times Flash, Timer LED 15 Times Flash, Filter LED Continuous Flash. Error Code : A1
--	---

Detective Actuators: Discharge temperature thermistor	Detective details: ▪ "Protection stop by "discharge temperature1 \geq 115°C during compressor operation"" generated 2 times within 40 minutes
---	---

Forecast of Cause :	1. 3-way valve not opened 2. EEV defective, strainer clogged 3. Outdoor unit operation defective, foreign matter on heat exchanger 4. Discharge temperature thermistor defective 5. Insufficient refrigerant
----------------------------	--

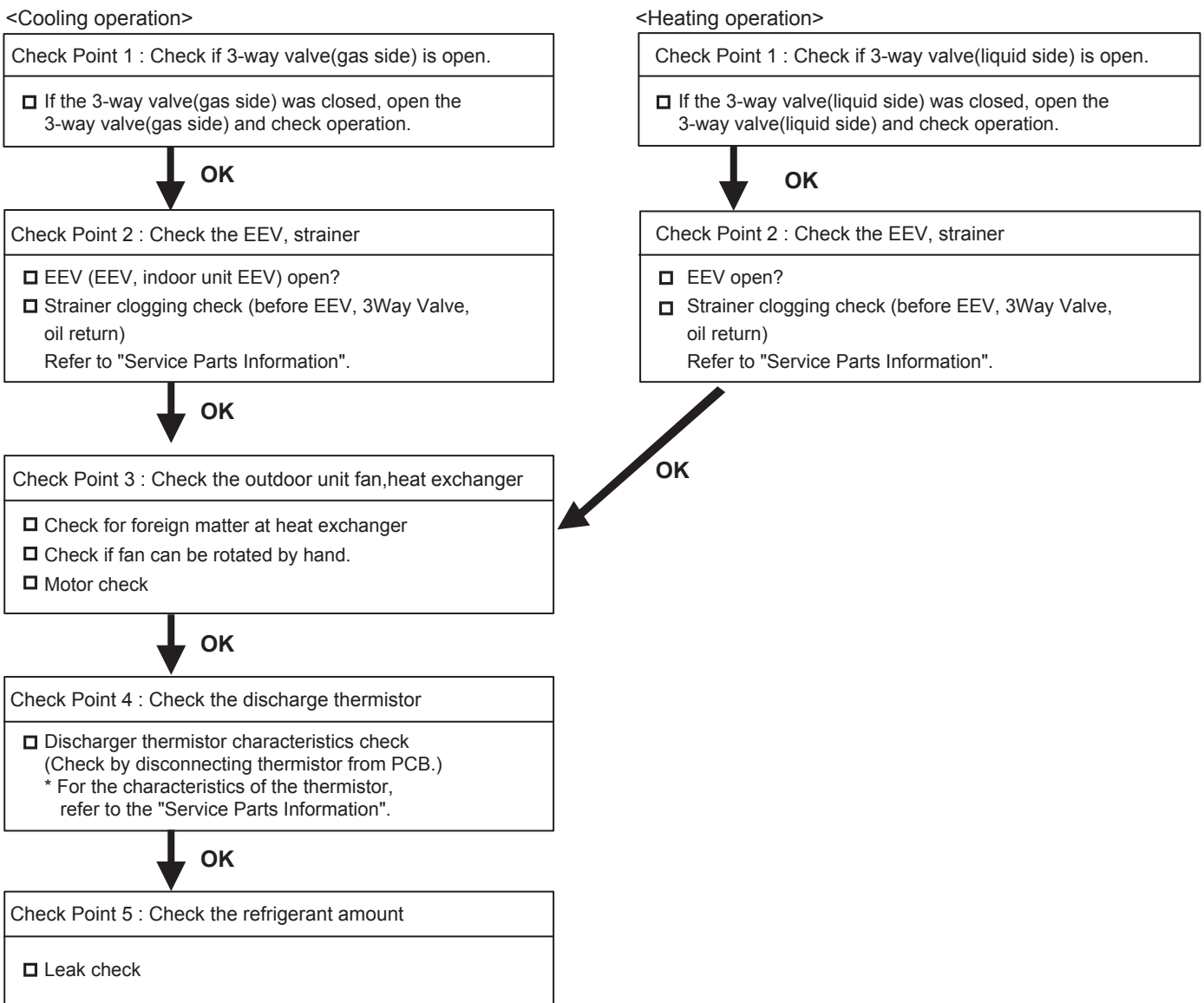

Trouble shooting 40 OUTDOOR UNIT Error Method: Compressor Temperature Abnormal	Indicate or Display: Outdoor Unit : E. A3. 1 Indoor Unit : Operation LED 9 times Flash, Timer LED 15 Times Flash, Filter LED Continuous Flash. Error Code : A3
---	---

Detective Actuators: Compressor temperature thermistor	Detective details: • "Protection stop by "compressor temperature" $\geq 110^{\circ}\text{C}$ during compressor operation" generated 2 times within 40 minutes
--	---

Forecast of Cause :	1. 3-way valve not opened 2. EEV defective, strainer clogged 3. Outdoor unit operation defective, foreign matter on heat exchanger 4. Compressor 1 temperature thermistor defective 5. Insufficient refrigerant
----------------------------	---

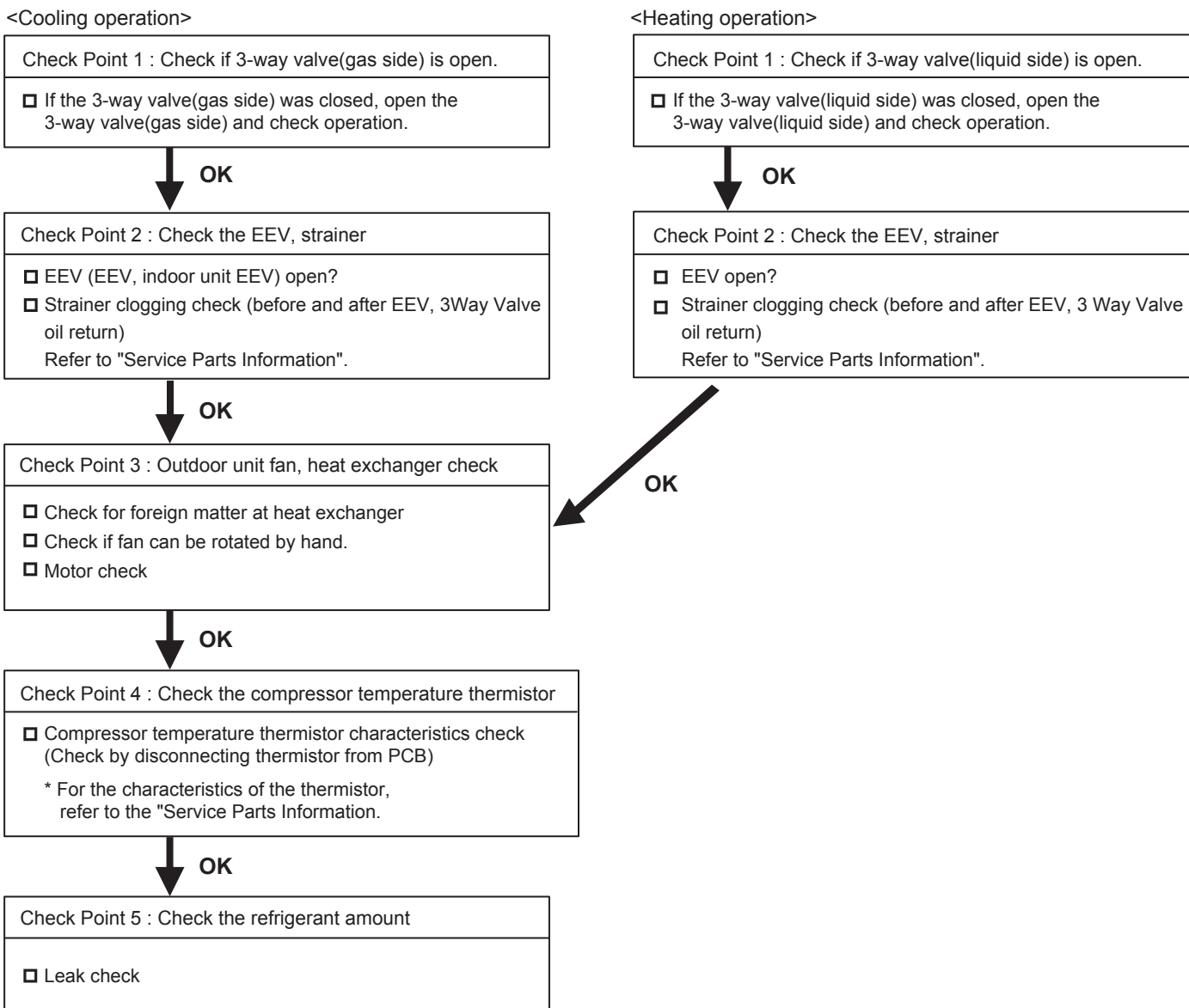

Trouble shooting 41 OUTDOOR UNIT Error Method: High Pressure Abnormal	Indicate or Display: Outdoor Unit : E. A4. 1 Indoor Unit : Operation LED 9 times Flash, Timer LED 15 Times Flash, Filter LED Continuous Flash. Error Code : A4
--	---

Detective Actuators: Judgment from value sensed by discharge pressure sensor	Detective details: ▪ "Protection stop by "discharge pressure \geq 4.00MPa during operation of any compressor"" generated 3 times within 60 minutes
--	--

Forecast of Cause :	1. 3-way valve not opened 2. Outdoor unit fan operation defective, foreign matter at heat exchanger, excessive ambient temperature rise 3. Check valve clogged 4. EEV defective, strainer clogged 5. Solenoid valve defective 6. Discharge pressure sensor defective 7. Refrigerant overcharged
----------------------------	---

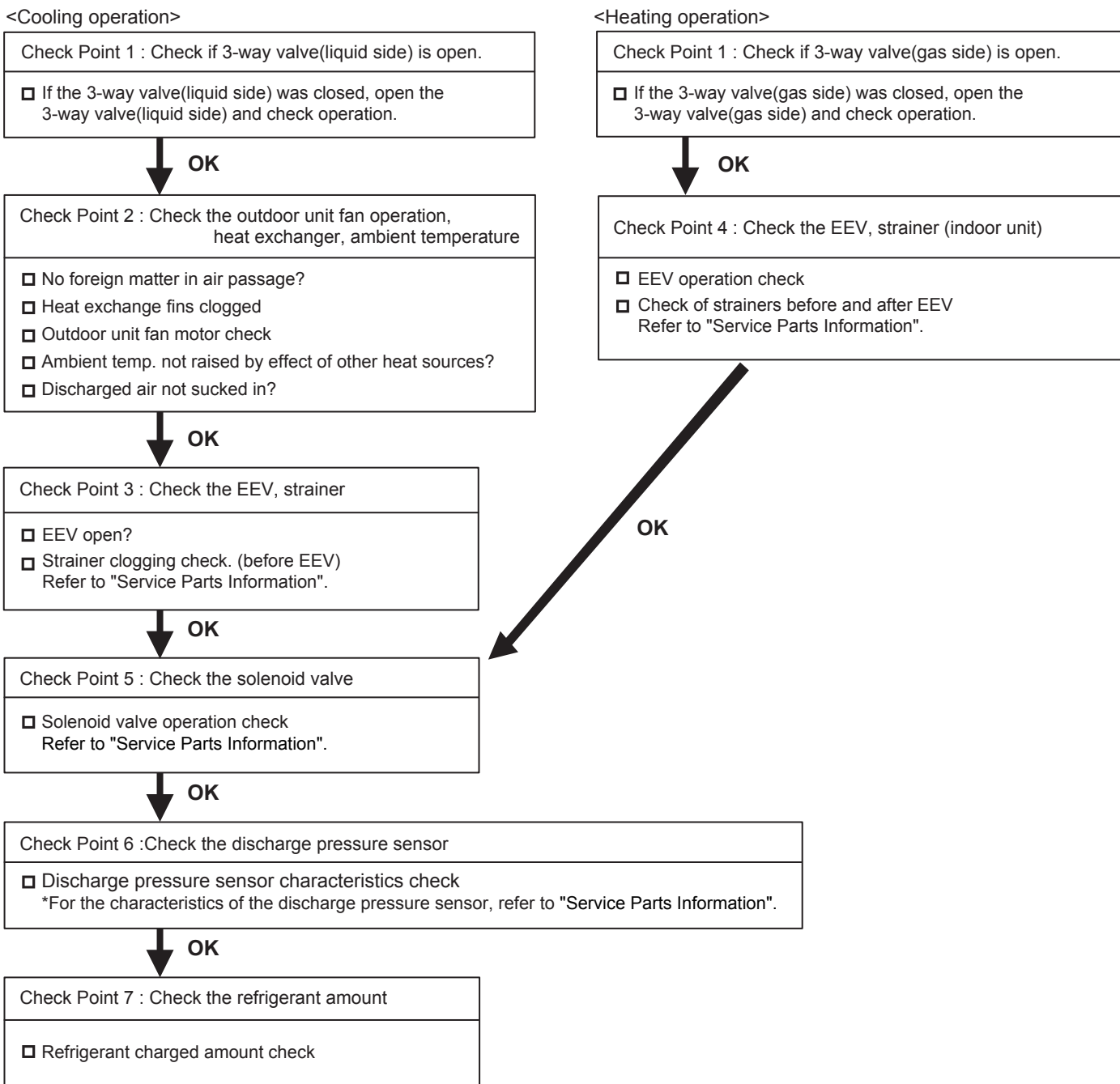

Trouble shooting 42 OUTDOOR UNIT Error Method: Low Pressure Abnormal	Indicate or Display: Outdoor Unit : E. A5. 1 Indoor Unit : Operation LED 9 times Flash, Timer LED 15 Times Flash, Filter LED Continuous Flash. Error Code : A5
---	---

Detective Actuators: Suction pressure sensor	Detective details: ▪ "Protection stop by "suction pressure \leq 0.10MPa continued for 10 minutes" or "suction pressure \leq 0.05MPa" during operation of any compressor"" was generated 5 times within 3 hours
--	--

Forecast of Cause : <ol style="list-style-type: none"> 1. 3-way valve not opened 3. Outdoor unit fan operation defective, foreign matter at heat exchanger 4. EEV defective, strainer clogged 6. Low pressure sensor characteristics defective <ol style="list-style-type: none"> 2. Outdoor unit ambient temperature too low 5. Solenoid valve defective 7. Insufficient refrigerant

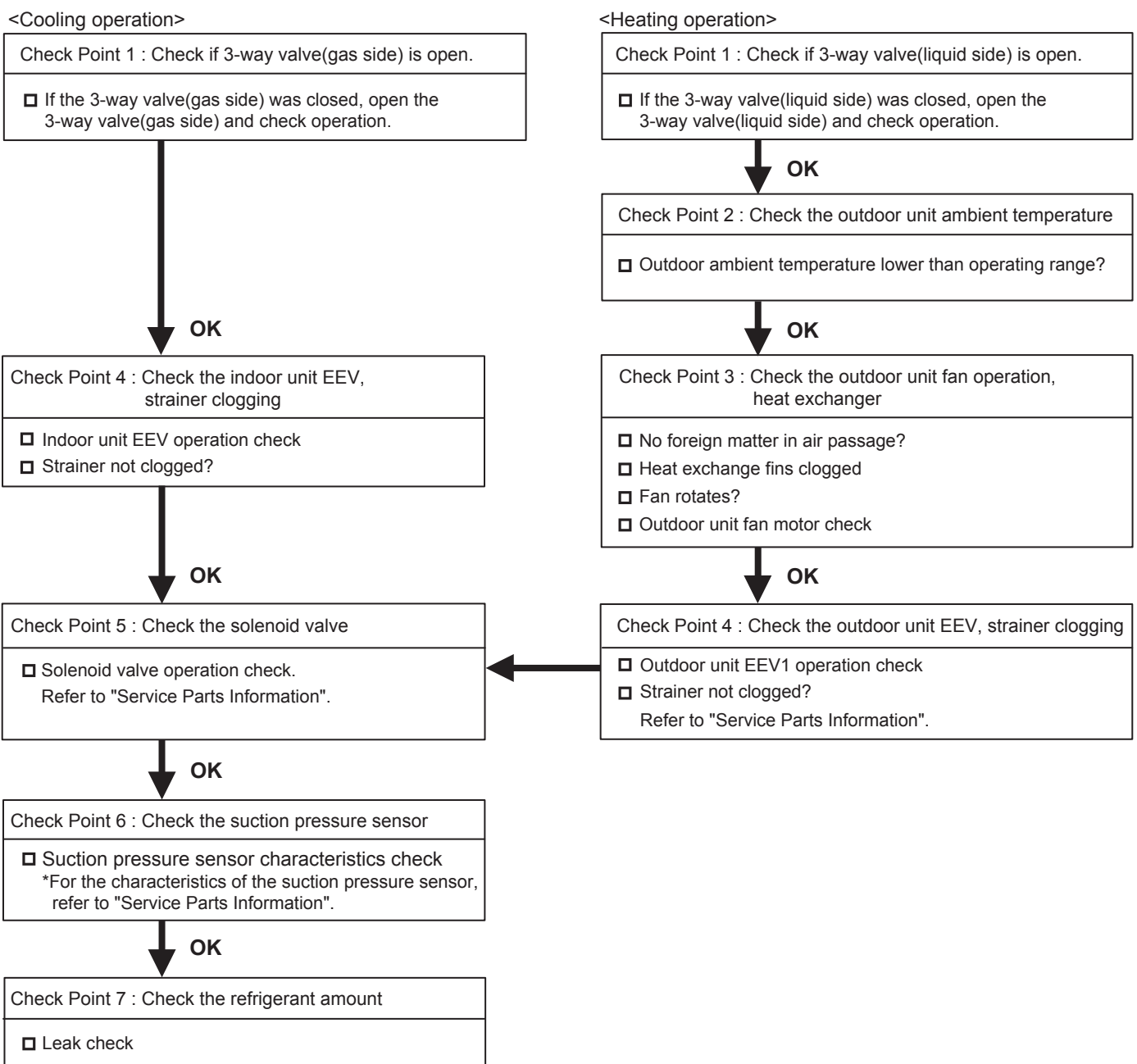

Trouble shooting 43 OUTDOOR UNIT Error Method: Outdoor unit Heat Sink Temperature Abnormal	Indicate or Display: Outdoor Unit : E. A C. 4 Indoor Unit : Operation LED 9 times Flash, Timer LED 15 Times Flash, Filter LED Continuous Flash. Error Code : 9 U / A C
---	---

Detective Actuators: Heat sink temp. sensor (IPM built in)	Detective details: ▪ "Protection stop by "heat sink temp. $\geq 100^{\circ}\text{C}$ generated 3 times within 60 minutes.
--	--

Forecast of Cause : <ol style="list-style-type: none"> 1. Foreign matter on heat sink, heat sink dirty 2. Foreign matter on heat exchanger, excessive ambient temperature rise 3. Heat sink temp. sensor defective
--

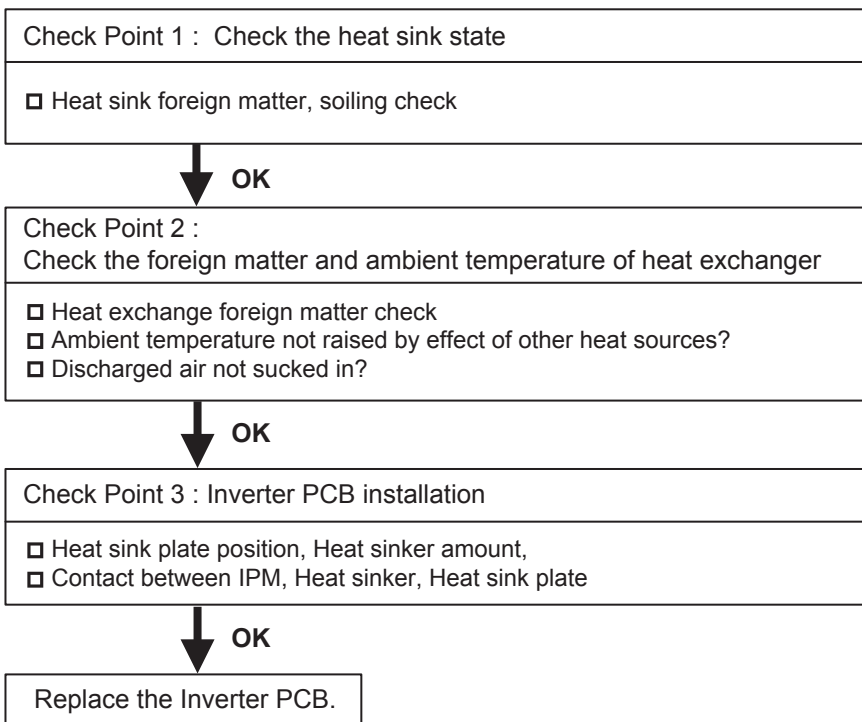

Trouble shooting 44 OUTDOOR UNIT Error Method: Auto Address Setting Error	Indicate or Display: Outdoor Unit : E. 28. 1 Indoor Unit : No Display Error Code : 28
--	--

Detective Actuators: Outdoor unit Main PCB	Detective details: ▪ When none of the connected indoor units answers during auto address And when abnormal answer signal is input.
--	---

Forecast of Cause :	1. Indoor unit power supply defective	2 Indoor unit overconnected
	3.Communication line incorrect connection	4. Noise, momentary open

Check Point 1 : Check the indoor unit power supply
<input type="checkbox"/> Check the indoor unit power supply

↓ **OK**

Check Point 2 : Check the indoor unit number connection
<input type="checkbox"/> Check if more than 64 indoor units are connected in a refrigerant circuit

↓ **OK**

Check Point 3 : Check the communication line connection
Check if communication line is correctly connected
<input type="checkbox"/> Is it uncoupled or cut halfway ?
<input type="checkbox"/> Connecting terminal position is correct as the installation manual shows ?

↓ **OK**

Check Point 4 : Check noise, momentary open, voltage drop
<input type="checkbox"/> Check if power supply temporarily stops by outages or if strong noise is generated from surrounding environment during auto address

Trouble shooting 45 OUTDOOR UNIT Error Method: Signal Amplifier Auto Address Error	Indicate or Display: Outdoor Unit : E. 28. 4 Indoor Unit : No Display Error Code : 28
---	--

Detective Actuators: Outdoor unit Main PCB	Detective details: ▪ When abnormal answer signal is input during signal amplifier auto address
--	--

Forecast of Cause :	1. Signal amplifier power supply defective	2. Signal amplifier overconnected
	3. Signal amplifier auto address wrong setting	4. Noise, momentary open.

Check Point 1 : Check signal amplifier unit power supply
<input type="checkbox"/> Check signal amplifier unit power supply

↓ **OK**

Check Point 2 : Check the signal amplifier number connection
<input type="checkbox"/> Check if more than 8 signal amplifiers are connected in a network

↓ **OK**

Check Point 3 : Check the operation of signal amplifier auto address setting
<input type="checkbox"/> Check if signal amplifier auto address is set at the same time from multiple outdoor units (master unit)

↓ **OK**

Check Point 4 : Check noise, momentary open, voltage drop
<input type="checkbox"/> Check if power supply temporarily stops by outages or if strong noise is generated from surrounding environment during signal amplifier auto address

Trouble shooting 46 OUTDOOR UNIT Error Method: The number of Indoor unit shortage	Indicate or Display: Outdoor Unit : E.1 4.5 Indoor Unit : No display Error Code : No display
--	---

Detective Actuators: Indoor unit Controller PCB circuit Indoor unit Communication PCB	Detective details: When the indoor unit number decreases for 180 seconds from the memorized maximum indoor units number after power(Breaker) ON.
--	--

Forecast of Cause :	1. Indoor unit power off 2. Noise, momentary open, voltage drop 3. Communication line connection defective 4. Terminal resistor setting mistake 5. Communication PCB mounting defective, Communication PCB defective 6. Controller PCB defective
----------------------------	---

Check Point 1 : Find the indoor unit that the communication is lost.
<input type="checkbox"/> Check system drawing and service tool.



Check Point 2 : Check the indoor unit power supply
<input type="checkbox"/> Main power ON check <input type="checkbox"/> Power cable connection and open check



Check Point 2 : Noise, momentary open, voltage drop
<input type="checkbox"/> Check if temporary voltage drop was not generated. <input type="checkbox"/> Check if momentary open was not generated. <input type="checkbox"/> Check if ground is connection correctly or there are no related cables near the power line.



Check Point 3 : Check the communication line connection
<input type="checkbox"/> Communication line connection, open check



Check Point 4 : Check the Terminal resistor setting
<input type="checkbox"/> Terminal resistor setting check



Check Point 5 : Check the communication PCB (indoor unit / outdoor unit)
<input type="checkbox"/> Communication PCB connection check <input type="checkbox"/> Communication PCB check



Check Point 6 : Replace Main PCB and Communication PCB (indoor unit / outdoor unit)
<input type="checkbox"/> Change Main PCB and Communication PCB, and set up the original address.

Attention!!
 Even if this error occurs, system does not stop. If the failure indoor unit is pinpointed and it needs to erase the error indication, it can be reset by function setting (F3-41: Maximum memorized indoor unit number reset).

Troubleshooting 114-1 OUTDOOR UNIT Error Method: Connecting indoor units capacity error Error at Indoor unit connection check	Indicate or Display: Outdoor Unit : E. 2 2. 1 Operation LED 2 times Flash, Timer LED 2 Times Flash, Filter LED Continuous Flash. Error Code : 9 U / 2 2
--	--

Detective Actuators: Outdoor unit Main PCB	Detective details: ▪ When error occurs during Indoor unit connection check
--	--

Forecast of Cause : <ul style="list-style-type: none"> 1. Indoor unit power supply defective 2 Indoor unit over connected 3. Communication line incorrect connection 4. Wrong Indoor unit address setting 5. Noise, momentary open
--

Check Point 1 : Check the indoor unit power supply <input type="checkbox"/> Check the indoor unit power supply

↓ **OK**

Check Point 2 : Check the connectable number of Indoor unit / connectable total capacity against the outdoor unit <input type="checkbox"/> Check the each limitations in the Design and Technical manual.
--

↓ **OK**

Check Point 3 : Check the communication line connection Check if communication line is correctly connected <input type="checkbox"/> Is it uncoupled or cut halfway ? <input type="checkbox"/> Connecting terminal position is correct as the installation manual shows ?

↓ **OK**

Check Point 4 : Check indoor unit address setting <input type="checkbox"/> Check if the same indoor unit address number are not existing in the same refrigerant address number.

↓ **OK**

Check Point 5 : Check noise, momentary open, voltage drop <input type="checkbox"/> Check if power supply temporarily stops by outages or if strong noise is generated from surrounding environment during auto address

↓ **OK**

Retry Indoor unit connection check Refer to P.04-55+4
--

Troubleshooting 114-2 OUTDOOR UNIT Error Method: Connecting number of indoor unit error Error at indoor unit connection check	Indicate or Display: Outdoor Unit : E. 2 4. 2 Operation LED 2 times Flash, Timer LED 4 Times Flash, Filter LED Continuous Flash. Error Code : 9 U / 2 4
--	--

Detective Actuators: Outdoor unit Main PCB	Detective details: ▪ When error occurs during Indoor unit connection check
--	--

Forecast of Cause :	1. Indoor unit power supply defective 2 Indoor unit over connected 3. Communication line incorrect connection 4. Wrong Indoor unit address setting 5. Noise, momentary open
----------------------------	---

Check Point 1 : Check the indoor unit power supply <input type="checkbox"/> Check the indoor unit power supply

↓ **OK**

Check Point 2 : Check the connectable number of Indoor unit / connectable total capacity against the outdoor unit <input type="checkbox"/> Check the each limitations in the Design and Technical manual.
--

↓ **OK**

Check Point 3 : Check the communication line connection Check if communication line is correctly connected <input type="checkbox"/> Is it uncoupled or cut halfway ? <input type="checkbox"/> Connecting terminal position is correct as the installation manual shows ?

↓ **OK**

Check Point 4 : Check indoor unit address setting <input type="checkbox"/> Check if the same indoor unit address number are not existing in the same refrigerant address number.

↓ **OK**

Check Point 5 : Check noise, momentary open, voltage drop <input type="checkbox"/> Check if power supply temporarily stops by outages or if strong noise is generated from surrounding environment during auto address

↓ **OK**

Retry Indoor unit connection check Refer to P.04-55+4
--

Troubleshooting 114-3 OUTDOOR UNIT Error Method: Dual address number is existing. Error at indoor unit connection check.	Indicate or Display: Outdoor Unit : E. 2 6. 1 Operation LED 2 times Flash, Timer LED 6 Times Flash, Filter LED Continuous Flash. Error Code : 9 U / 2 6
---	---

Detective Actuators: Outdoor unit Main PCB	Detective details: ▪ When error occurs during Indoor unit connection check
--	--

Forecast of Cause :	1. Indoor unit power supply defective 2 Indoor unit over connected 3. Communication line incorrect connection 4. Wrong Indoor unit address setting 5. Noise, momentary open
----------------------------	---

Check Point 1 : Check the indoor unit power supply
<input type="checkbox"/> Check the indoor unit power supply

↓ **OK**

Check Point 2 : Check the connectable number of Indoor unit / connectable total capacity against the outdoor unit
<input type="checkbox"/> Check the each limitations in the Design and Technical manual.

↓ **OK**

Check Point 3 : Check the communication line connection
Check if communication line is correctly connected
<input type="checkbox"/> Is it uncoupled or cut halfway ?
<input type="checkbox"/> Connecting terminal position is correct as the installation manual shows ?

↓ **OK**

Check Point 4 : Check indoor unit address setting
<input type="checkbox"/> Check if the same indoor unit address number are not existing in the same refrigerant address number.

↓ **OK**

Check Point 5 : Check noise, momentary open, voltage drop
<input type="checkbox"/> Check if power supply temporarily stops by outages or if strong noise is generated from surrounding environment during auto address

↓ **OK**

Retry Indoor unit connection check Refer to P.04-55+4
--

Indoor unit connection check

● SWITCH POSITION

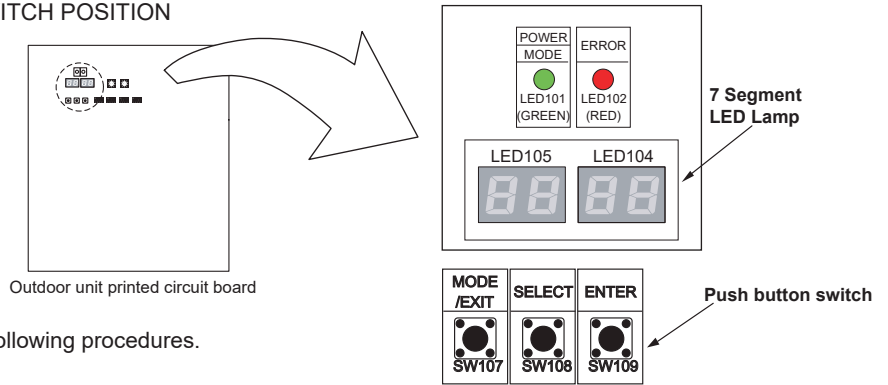

Please perform the indoor unit connection check according to following procedures.

- Turn on the power of indoor unit and outdoor unit.

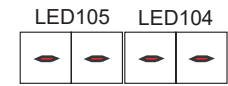

MODE/EXIT



Set to Function mode [F3].

SELECT



SELECT

(When [F4] to [F9] are displayed, continue to press the "SELECT" button until [F3] is displayed.)



ENTER

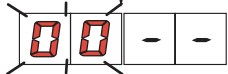

SELECT

Press the "SELECT" button until "12" is displayed.



ENTER

- Press the "ENTER" button for more than 3 seconds.



When indoor unit connection check can not be performed



• This will be displayed when the Indoor unit connection check starts.

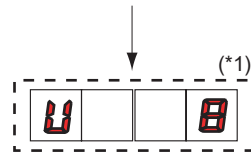

- Confirm the number of connected indoor units and the volume ratio of the indoor units connection.

SELECT

(*1) The number of connected indoor units
Ex.) When 8 units are connected

ENTER

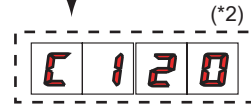

(*2) Volume ratio of the indoor units connection
Ex.) When the ratio is 120%

ENTER

- Exit indoor unit connection check mode.

When error occurs



ENTER



MODE/EXIT



When it finishes normally, nothing will be displayed on 7 segment display.



Please refer to the following "Error code" for details

- [Note] Error code
- 22.1: Connecting Indoor units capacity error
 - 24.2: Connecting number of indoor unit error
 - 26.1: Dual address number is existing
 - Other Error code: Refer to the Trouble shooting

4-3-3 TROUBLE SHOOTING WITH NO ERROR CODE

Trouble shooting 47

Indoor Unit - No Power

Forecast of Cause :

1. Power Supply failure 2. Outside cause 3. Electrical Component defective

Check Point 1 : Check Installation Condition

- Is not the breaker down?
- Check loose or removed connection cable.
- >>If abnormal condition is found, correct it by referring to Installation Manual or Data & Technical Manual.**

OK

Check Point 2 : Check Outside Cause such as Voltage drop or Noise

- Instant drop ----- Check if there is a large load electric apparatus in the same circuit.
- Momentary power failure ----- Check if there is a defective contact or leak current in the power supply circuit.
- Noise ----- Check if there is any equipment causing harmonic wave near electric line (Neon bulb or electric equipment that may cause harmonic wave).
Check the complete insulation of grounding.

OK

Check Point 3 : Check Electrical Components

- Check Voltage of power supply.
- >> Check AC230V appears at Indoor Unit Terminal 1 - 2 (Power Supply).**



NG

OK

- Check the fuse and thermal fuse.

OK

NG

- Replace the fuse or thermal fuse.
- Check if the power supply terminals section is shorted.

OK

NG

- For AS model, advance to OK without checking.
- For models other than the AS model, disconnect the cable connecting the Power Supply PCB and controller PCB and recheck if the power supply terminals section is not shorted.
- (Note) Always check in the power off state.

NG

- Replace the controller PCB.

OK

- Replace the Power Supply PCB.

NG

- Replace the Display PCB.

NG

► If the symptom does not change by above Check 3, replace Controller PCB or Power Supply PCB.

Trouble shooting 48
Outdoor Unit - No Power

Forecast of Cause :

1.Power Supply failure 2. Outside cause 3. Electrical Components defective

Check Point 1 : Check Installation Condition

- Isn't the breaker down?
- Check loose or removed connection cable.
- >>If abnormal condition is found, correct it by referring to Installation Manual or Data & Technical Manual.**

OK

Check Point 2 : Check Outside Cause such as Voltage drop or Noise

- Instant drop ----- Check if there is a large load electric apparatus in the same circuit.
- Momentary power failure ----- Check if there is a defective contact or leak current in the power supply circuit.
- Noise ----- Check if there is any equipment causing harmonic wave near electric line (Neon bulb or electric equipment that may cause harmonic wave).
 Check the complete insulation of grounding.

OK

Check Point 3 : Check Electrical Components



- Check the voltage of power supply.
- >> Check if the reted voltage appears at Outdoor Unit Terminal L - N.**

NO

OK

- Check the fuse on the Filter PCB.

NG

- Replace the fuse.
- Recheck if the power supply terminals section is shorted.
- (Note) Always check in the power off state.

NG

- Disconnect connecting cable of the Filter PCB and Main PCB and recheck.
- if the power supply terminals section is not shorted.
- (Note) Always check in the power off state.

OK

NG

- Check if the FAN motor PCB has a damage or not. (Check short circuit)

OK

NG

- Replace the FAN Motor

- Check if the circuit between pin No. 1 and pin No.2 of CN102 on the Main PCB has short circuit or not (Short circuit : NG)
- *Disconnect FAN motor when check the circuit

NG

NG

- Replace the Inverter PCB

NG

- If the symptom does not change by above Check 3, replace Main PCB or Filter PCB

Trouble shooting 49

No Operation (Power is ON)

Forecast of Cause :

1. Setting/Connection failure
2. Outside cause
3. Electrical Component defective

Check Point 1 : Check indoor and outdoor installation condition

- Indoor Unit - Check incorrect wiring between Indoor Unit- Remote Control, or terminals between Indoor Units.
Or, check if there is an open cable connection.
 - Check address setting (Are all the address of Indoor and Outdoor correct?)
 - Are these Indoor Unit, Outdoor Unit, and Remote Control suitable model numbers to connect?
- >> **If there is some abnormal condition, correct it by referring to Installation manual and Data & Technical Manual.**

↓
OK

Turn off Power and check/correct followings.

- Isn't Communication PCB of Indoor Unit removed?
- Is there loose or removed communication line of Indoor Unit and Outdoor Unit?
- Check Terminator (DIP-SW SET 5) is installed on Outdoor Main PCB.
- Check loose or removed communication line between each Outdoor Unit.
- Check loose Communication PCB of each Outdoor Unit.

↓
OK

Check Point 2 : Check outside cause at Indoor and Outdoor (Voltage drop or Noise)

- Instant drop -----Check if there is a large load electric apparatus in the same circuit.
- Momentary power failure ----- Check if there is a defective contact or leak current in the power supply circuit.
- Noise ----- Check if there is any equipment causing harmonic wave near electric line (Neon bulb or electric equipment that may cause harmonic wave).
Check the complete insulation of grounding.

↓
OK

Check Point 3 : Check Electrical Components at Indoor and Outdoor



- Indoor Unit - Check the voltage between pins 1-3 of the connector (on the control PCB) for connection with the remote controller.
>> **If it is DC12V, Remote Control is defective (Controller PCB is normal) >> Replace Remote Control**
>> **If it is DC 0V, Controller PCB is defective (Check Remote Control once again) >> Replace Controller PCB**
- If some of Indoor unit does not operate, replace the Communication PCB of the non-operative Indoor Unit.
>> **If the symptom does not change, replace Controller PCB of Indoor Unit.**
- If all of Indoor Units do not operate, check the connection between Main PCB and Communication PCB of Outdoor Unit (Main Unit).
>> **If the symptom does not change, replace Communication PCB of Outdoor Unit (Main Unit).**
(If it did not work, replace Main PCB.)

Trouble shooting 50

No Cooling

Forecast of Cause :

1. Indoor Unit error
2. Outdoor Unit error
3. Effect by Surrounding environment
4. Connection Pipe / Connection Wire failure
5. Refrigeration cycle failure

Check Point 1 : Check Indoor Unit

- Does Indoor Unit FAN run on HIGH FAN?
- Is Air Filter dirty?
- Is Heat Exchanger clogged?



Check Point 2 : Check Outdoor Unit Operation

- Check if Outdoor Unit is operating
- Check any objects that obstruct the air flow route.
- Check clogged Heat Exchanger.
- Is the Valve open?



Check Point 3 : Check Site Condition

- Is capacity of Indoor Unit fitted to Room size?
- Any windows open? Or direct sunlight ?



Check Point 4 : Check Indoor/Outdoor Installation Condition

- Check connection pipe (specified pipe length & Pipe diameter?)
- Check any loose or removed communication line.
- >> **If there is an abnormal condition, correct it by referring to Installation Manual or Data & Technical Manual.**



Check Point 5 : Check Refrigeration Cycle

- Check if Strainer is clogged (Refer to the figure at right).
- Measure Gas Pressure and if there is a leakage, correct it.
- >> **When recharging the refrigerant, make sure to perform vacuuming, and recharge the specified amount.**
- ▶ Check EEV
- ▶ Check Solenoid Valve (Refer to Service Parts Information)
- ▶ Check Compressor (Refer to Service Parts Information)

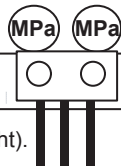

Attention!!

Strainer normally does not have temperature difference between inlet and outlet as shown in (1), but if there is a difference like shown in (2), there is a possibility of inside clogged. In this case, replace Strainer.

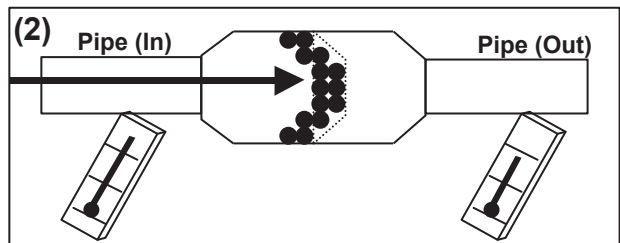
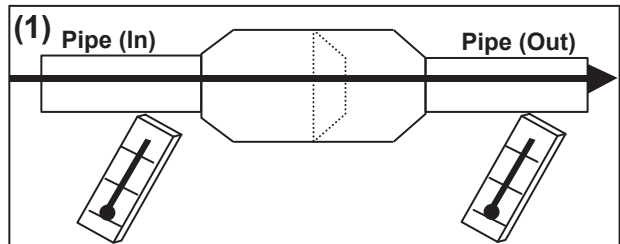

Trouble shooting 51

Abnormal Noise

Forecast of Cause :

1. Abnormal installation (Indoor/Outdoor)
2. Fan failure (Indoor / Outdoor)
3. EEV failure (Indoor)
4. Compressor failure (Outdoor)

Diagnosis method when Abnormal Noise is occurred

Abnormal noise is coming from Indoor Unit
(Check and correct followings)

- Is Main Unit installed in stable condition?
- Is the installation of Air suction grille and front panel normal?
- In case of Duct type : Is Static Pressure range normal?
(Refer to Data & Technical Manual)

OK

- Is Fan broken or deformed?
- Is the screw of Fan loose?
- Is there any object which obstruct the Fan rotation?

Attention!!

- If Refrigerant Noise is occurring, Check if the Indoor and Outdoor Thermistor is wrongly installed. Check and correct the thermistor.
- Check the refrigerant additional charging amount. When the refrigerant is not enough, add the refrigerant. However, the total refrigerant amount is prevented from more than 6.83kg.

Abnormal noise is coming from Outdoor Unit
(Check and correct followings)

- Is Main Unit installed in stable condition?
- Is Bell Mouth installed normally?

OK

- Is Fan broken or deformed?
- Is the screw of Fan loose?
- Is there any object which obstruct the Fan rotation?

OK

- Check if vibration noise by loose bolt or contact noise of piping is happening.

OK

- Is Compressor locked?
>> Check Compressor (Refer to Service Parts Information)

Trouble shooting 52

Water Leaking

Forecast of Cause :

1. Erroneous installation
2. Drain hose failure
3. Float Switch failure

Diagnosis method when water leak occurs

- Is Main Unit installed in stable condition?
- Is Main Unit broken or deformed at the time of transportation or maintenance?

OK

- Is Drain Hose connection loose?
- Is there a trap in Drain Hose?
- Is Drain Hose clogged?

OK

- Is Fan rotating?
>> Check Fan Motor (Refer to Service Parts Information)

OK

- Is Float Switch defective?
>> Check Float Switch (Refer to Trouble Shooting)

Diagnosis method when water is spitting out

- Is the filter clogged?

OK

- Check Gas Pressure and correct it if there was a gas leak.

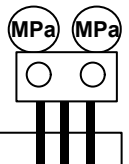

Attention!!

If water is leaking from the Indoor Unit that is not in operation, there is a possibility of Indoor EEV is not closed.

=> Check EEV (Refer to Service Parts Information)

4-3-4 Trouble Shooting for Optional Parts

1. External Switch Controller (UTY-TEKX)

Trouble shooting 53

Error Contents :

Power Supply Error

Symptom :

No operation & LED does not light up.

Condition :

1. No power supply.
Voltage error between red and black terminals of External Switch Controller. (Normal voltage: 12V plus minus 10%)
2. Electric circuit error.
Voltage is normal between red and black terminals of External Switch Controller (Normal voltage: 12V plus minus 10%)

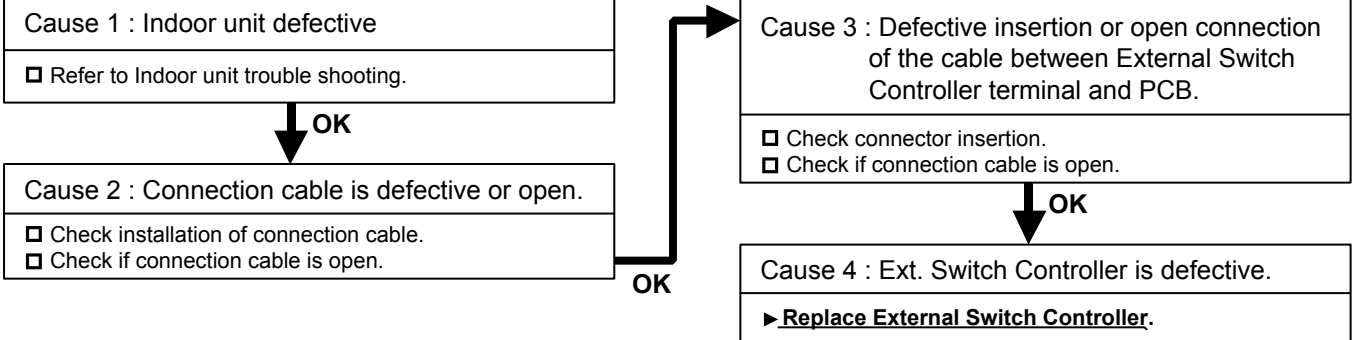

Trouble shooting 54

Error Contents :

The abnormality in connection of remote controller cable

Symptom :

LED repeats flashing 0.5sec ON & 0.5sec OFF.

Condition :

Communication with Indoor unit has been cut off for longer than 1 minute.

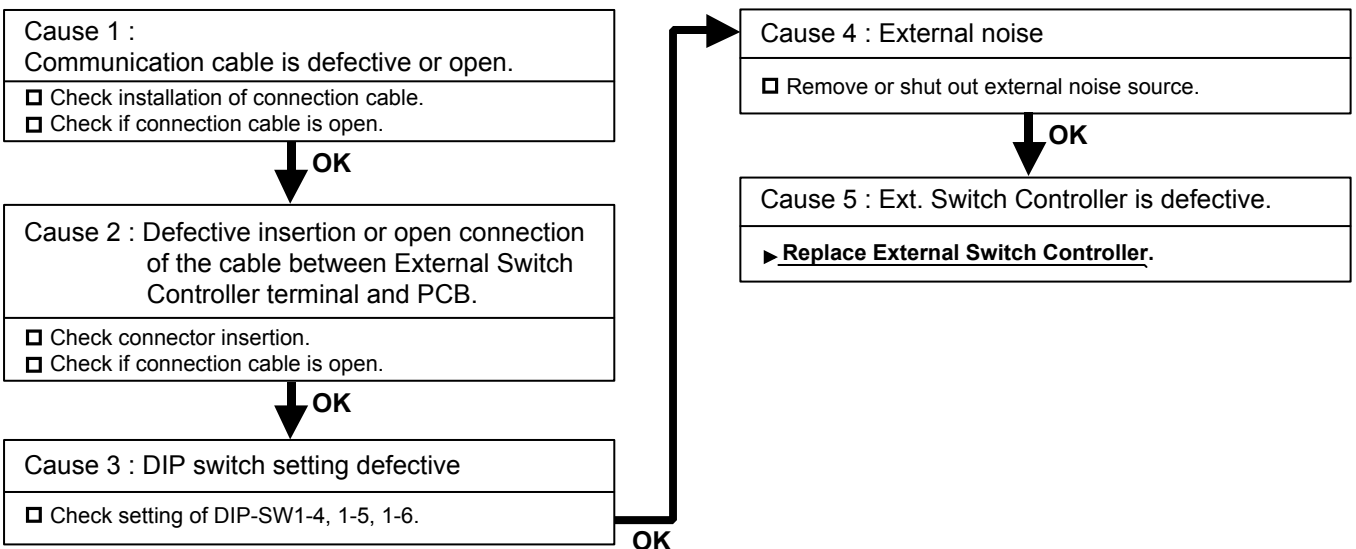

Trouble shooting 55	
Error Contents : Transmission Error	Symptom : LED repeats flashing 0.5sec ON & 1.0sec OFF.
Condition : Normal communication with Indoor unit has been suspended for longer than 1 minute.	

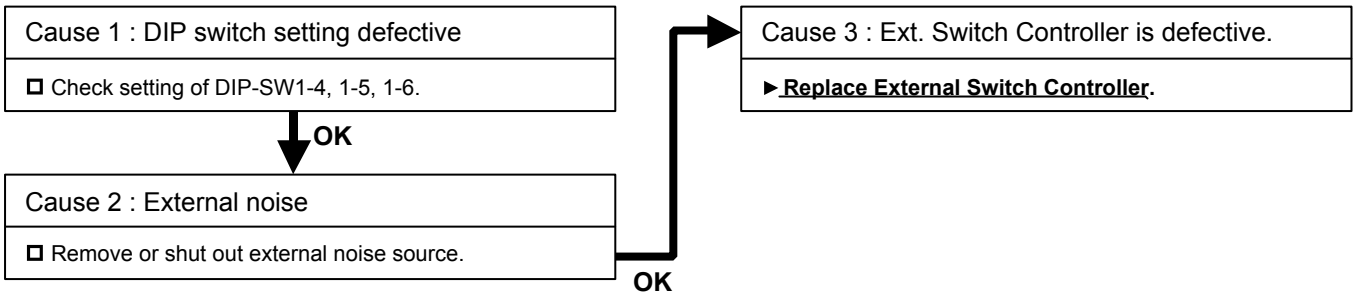

Trouble shooting 56	
Error Contents : Switch Operation Error	Symptom : LED is lighting but Switch (SW1 or SW2) does not operate.
Condition : Switch input can not be detected.	

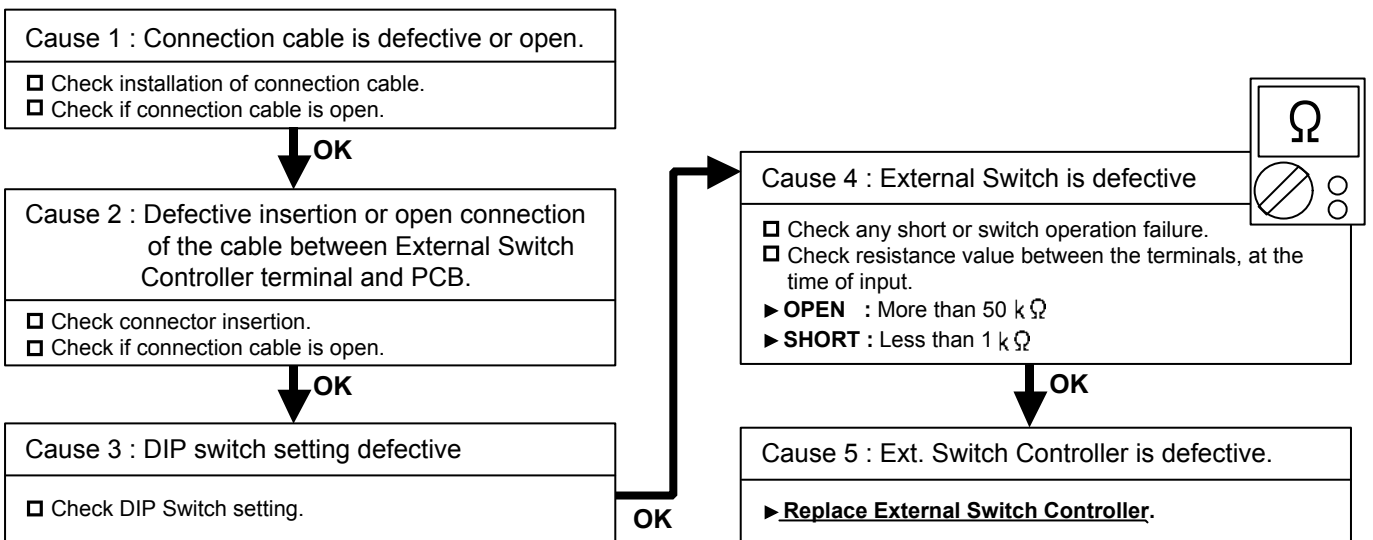

2. Signal Amplifier (UTY-VSGXZ1)

Trouble shooting 57

Error Contents :
Power Supply Error

Symptom :
No display

Details :

Condition of occurrence : Normal power is not supplied. 7 segment indicator is defective.
Release condition : Normal power is supplied. 7 segment indicator is normal.

Cause 1 :
Power supply cable installation is defective or open.

- Check following installation and reset the power supply.
- (1) Installation of power cable on power supply terminal.
- (2) Connection between Power PCB and Terminal.
- (3) Connector condition between power PCB and Main PCB.

OK

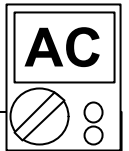

Cause 2 : Signal Amplifier is defective.

If normal voltage (Rated Voltage) is applied to power supply terminal of Signal Amplifier, there is a possibility of defective PCB. Proceed as follows.

► **Replace Signal Amplifier.**

Trouble shooting 58

Error Contents :
Communication Error

Symptom :
Error code does not appear [_ _]
Communication error occurs at connected equipment side.

Details :

Condition of occurrence : Network cable defective. External noise is applied.
Overlapping of Signal Amplifier address setting. System design mistake.
Release condition : Network cable is connected. External noise is removed.
Overlapping of Signal Amplifier has been corrected. System design is normal.

Cause 1 :
Network cable installation is defective or open.

- Check Network cable installation.

OK

Cause 2 : External noise

- Remove external noise around Signal Amplifier or Network cable. (Keep enough distance)

OK

Cause 3 :
Overlapped address of Signal Amplifier.

- Set up address again which does not overlap on system.
After set up again, reset the power supply.

OK

Cause 4 : System Design mistake

- Check following items.(Refer to Installation Manual)
- (1) Installation location of Terminal Resistor.
(Only 1 location on NS*)
- (2) Cable length. (Within 500m maximum on NS*)
- (3) Number of units connected
(Up to 64 units maximum on NS*)
- (4) Communication cable specification.
(Use specified type.)
- (5) Number of Signal Amplifier installed.
(Up to 8 units max. on system)
- (6) Network cable shall not be connected in loop.

*NS : Network Segment

Trouble shooting 59

<p>Error Contents : Address Setting Error</p>	<p>Symptom : Error display [2 6] No operation.</p>
<p>Details : Condition of occurrence : Address is not set at Signal Amplifier. Release condition : Address setting mode is started up, and desired address has been set up.</p>	

Cause 1 : External noise

Upon pressing RESET button (SW7) or turning on power, proceed as follows.

(1) If error did not appear, it is not a defect of PCB. Remove the surrounding noise source.

(2) If error occurs again, check followings other than removing surrounding noise source.

Cause 2 : Address is not set at Signal Amplifier.

Set up address again.
 After set up again, reset the power supply.

Cause 3 : Signal Amplifier is defective.

▶ **Replace Signal Amplifier.**



Trouble shooting 60

<p>Error Contents : Parallel Communication Error</p>	<p>Symptom : Error display [C 1] No operation.</p>
<p>Details : Condition of occurrence : Communication error between CPU and Network Driver IC Release condition : Communication is normal between CPU and Network Driver IC</p>	

Cause 1 : External noise

Upon pressing RESET button (SW7) or turning on power, proceed as follows.

(1) If error did not appear, it is not a defect of PCB. Remove the surrounding noise source.

(2) If error occurs again, check followings other than removing surrounding noise source.

Cause 2 : Signal Amplifier is defective.

▶ **Replace Signal Amplifier.**



Trouble shooting 61

Error Contents : Communication Error B	Symptom : Error display [D9 (Flashing or Lighting)] No operation.
Details : Condition of occurrence : Communication error between CPU and Network Driver IC (CH_B side). Network Driver IC is defective. Release condition : Communication is normal between CPU and Network Driver IC (CH_B side). Network Driver IC operation is normal.	

Cause 1 : External noise

□ Upon pressing RESET button (SW7) or turning on power, proceed as follows.

(1) If error did not appear, it is not a defect of PCB. Remove the surrounding noise source.

(2) If error occurs again, check followings other than removing surrounding noise source.

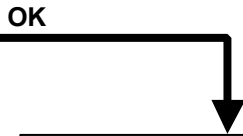

Cause 2 :Signal Amplifier is defective.

► **Replace Signal Amplifier.**

Trouble shooting 62

Error Contents : Communication Error A	Symptom : Error display [D14 (Flashing or Lighting)] No operation.
Details : Condition of occurrence : Communication error between CPU and Network Driver IC (CH_A side). Network Driver IC is defective. Release condition : Communication is normal between CPU and Network Driver IC (CH_A side). Network Driver IC operation is normal.	

Cause 1 : External noise

□ Upon pressing RESET button (SW7) or turning on power, proceed as follows.

(1) If error did not appear, it is not a defect of PCB. Remove the surrounding noise source.

(2) If error occurs again, check followings other than removing surrounding noise source.

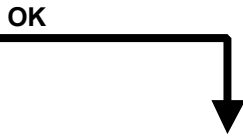

Cause 2 : Signal Amplifier is defective.

► **Replace Signal Amplifier.**

3. Network Converter (UTY-VGGXZ1)

1. When connecting a group remote controller to a network converter

Trouble shooting 63

Error Contents :
Power Supply Error

Symptom :
No display

Details :

Condition of occurrence : Normal power is not supplied. 7 segment indicator is defective.
Release condition : Normal power is supplied. 7 segment indicator is normal.

Cause 1 :
Power supply cable installation is defective or open.

- Check following installation and reset the power supply.
- (1) Installation of power cable on power supply terminal.
- (2) Connection between Power PCB and Terminal.
- (3) Connector condition between power PCB and Main PCB.

OK

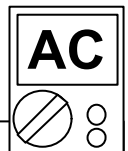

Cause 2 : Network Converter is defective.

If normal voltage (Rated Voltage) is applied to power supply terminal of Network Converter, there is a possibility of defective PCB. Proceed as follows.

► **Replace Network Converter.**

Trouble shooting 64

Error Contents :
PCB Error 1

Symptom :
Error Code display [C 1]
All the control items do not operate.

Details :

Condition of occurrence : Synchronization of Network Device was not normally done.
Release condition : When the synchronization of the device is normally done.

Cause 1 : External noise

- After pressing SW104 of Network Converter PCB for 5 seconds or turning on power.
Does error code display reappear?

YES

NO

- Remove the surrounding noise source.

- It is not a defect of PCB. Remove the surrounding noise source.

OK

Cause 2 : Network Converter is defective.

► **Replace Network Converter.**

Trouble shooting 65

Error Contents :

Communication Error with Group Remote Controller

Symptom :

Error Code display [1 2] Control/Display from Group Remote is not available.

Details :

Condition of occurrence : The communication between Group Remote and Network Converter was not normally performed.

Release condition : When the communication between Group Remote and Network Converter resumes normal operation.

Cause 1 : External noise

- After pressing SW104 of Network Converter PCB for 5 seconds or turning on power.
Does error code display reappear?

YES

NO

- Remove the surrounding noise source.

- It is not a defect of PCB. Remove the surrounding noise source.

OK

Cause 2 :

Defective or open connection of cable wire between Network Converter and Connected Remote Controller.

After the following are checked, the power supply is reset.

- Check connection cable wire between Network Converter and Connected Remote Controller.
- Check connection between Control PCB and Terminal.

OK

Cause 3 : Incorrect setting of Network Converter's DIP-SW103[1 to 4] (For Converter setting of Group Remote Controller)

- Check Network Converter PCB DIP-SW103[1 to 4] ON.

OK

Cause 4 : Defective Remote Controller or Network Converter.

- ▶ **Replace Remote Controller or Network Converter.**

Trouble shooting 66

Error Contents :
Software Error

Symptom :
Error Code display [C A]
All the control items do not operate.
Other Controls are left they are.

Details :

Condition of occurrence : Micon program performed an abnormal control.
Error of inside information of EEPROM.
initial setting of Network Converter PCB was not normally performed.
Release condition : Micon has been reset, and the control of Network Converter became normal.
When error disappeared and Network Converter becomes available to control.

Cause 1 : External noise

Check continuation of error.
(1) If error is released automatically, it is not a defect of PCB. Remove the surrounding noise source around Network Converter.
(2) If error is not released automatically, check followings.

↓ OK

After pressing SW104 of Network Converter PCB for 5 seconds or turning on power.
Does error code display reappear?

↓ YES

- Remove the surrounding noise source.

↓ NO

- It is not a defect of PCB. Remove the surrounding noise source.

↓ OK

Cause 2 : Network Converter is defective.

▶ **Replace Network Converter.**

Trouble shooting 67

Error Contents :
Refrigerant circuit address setting error

Symptom :
Error Code display [2 6]

Details :

Condition of occurrence : Indoor unit registration is 3 refrigerant circuits or more.
Release condition : Indoor unit registration is 2 refrigerant circuits or less.

Cause 1 : Check of number of indoor unit registration refrigerant circuits

Check indoor unit registration.
(1) Number of refrigerant circuits of indoor unit registered at Replace Group Remote Controller is 3 refrigerant circuits or more even though connected to one converter.

↓ YES

Make 2 refrigerant circuits or less
and wait 2 minutes

↓ NO

Replace Network Converter
Replace Group Remote Controller

3. Network Converter (UTY-VGGXZ1)

2. When connecting a single split type indoor unit to a network converter

Trouble shooting 68

Error Contents :
Power Supply Error

Symptom :
No display

Details :

Condition of occurrence : Normal power is not supplied. 7 segment indicator is defective.
Release condition : Normal power is supplied. 7 segment indicator is normal.

Cause 1 :
Power supply cable installation is defective or open.

- Check following installation and reset the power supply.
- (1) Installation of power cable on power supply terminal.
- (2) Connection between Power PCB and Terminal.
- (3) Connector condition between power PCB and Main PCB.

OK

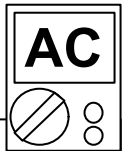

Cause 2 : Network Converter is defective.

If normal voltage (220V) is applied to power supply terminal of Network Converter, there is a possibility of defective PCB. Proceed as follows.
► **Replace Network Converter.**

Trouble shooting 69

Error Contents :
PCB Error 1

Symptom :
Error Code display [C 1]
All the control items do not operate.

Details :

Condition of occurrence : Synchronization of Network Device was not normally done.
Release condition : When the synchronization of the device is normally done.

Cause 1 : External noise

- After pressing SW104 of Network Converter PCB for 5 seconds or turning on power.
Does error code display reappear?

YES

NO

- Remove the surrounding noise source.

- It is not a defect of PCB. Remove the surrounding noise source.

OK

Cause 2 : Network Converter is defective.

- **Replace Network Converter.**

Trouble shooting 70

Error Contents :

Communication Error with Standard Remote Controller

Symptom :

Error Code display [1 2] Control/Display from Standard Remote is not available. Other controls are left as they are.

Details :

Condition of occurrence : The communication between Standard Remote Controller and Network Converter was not normally performed.

Release condition : When the communication between Standard Remote Controller and Network Converter resumes normal operation.

Cause 1 : External noise

- After pressing SW104 of Network Converter PCB for 5 seconds or turning on power. Does error code display reappear?

↓ YES

↓ NO

- Remove the surrounding noise source.

- It is not a defect of PCB. Remove the surrounding noise source.

↓ OK

Cause 2 :

Defective or open connection of cable wire between Network Converter and Connected Remote Controller.

After the following are checked, the power supply is reset.

- Check connection cable wire between Network Converter and Connected Remote Controller.
 Check connection between Control PCB and Terminal.

↓ OK

Cause 3 : Incorrect setting of Network Converter's DIP-SW107[2] (Wired RC Validity setting)

- Check Network Converter PCB DIP-SW107[2].

↓ OK

Cause 4 : Incorrect selection of Remote Controller

- Check connection Remote Controller. (Is it specified with the Installation Manual of Network Converter?)

↓ OK

Cause 5 :

Incorrect setting of Remote Controller's DIP-SW (Number of connected remote controllers)

- Check DIP-SW of Remote Controller.

↓ OK

Cause 6 : Defective Remote Controller or Network Converter.

- ▶ **Replace Remote Controller or Network Converter.**

Trouble shooting 71

Error Contents :
Communication Error with Indoor Unit

Symptom :
Error Code display [1 6]
All the control items do not operate.

Details :

Condition of occurrence : The communication between Indoor unit and Network Converter was not performed normally.
Release condition : When the communication with Indoor unit is resumed normally.

Cause 1 : External noise

After pressing SW104 of Network Converter PCB for 5 seconds or turning on power.
Does error code display reappear?

↓ YES

↓ NO

● Remove the surrounding noise source.

● It is not a defect of PCB. Remove the surrounding noise source.

↓ OK

Cause 2 : Defective or open connection of Remote Control cable between Network Converter and Indoor Unit.

After the following are checked, the power supply is reset.

- Check connection cable wire between Network Converter and Indoor unit.
- Check connection between Control PCB and Terminal.

↓ OK

Cause 3 : Power to Indoor unit is shut down.

- Check the power to Indoor unit.

↓ OK

Cause 4 : Incorrect setting of main unit address of Indoor unit.

- Check main unit address setting of Indoor unit.

↓ OK

Cause 5 : Incorrect setting of DIP-SW of Network Converter. Mis-read of Indoor unit type and RC type.

- Check DIP-SW103[1 to 8] of Network Converter (Indoor unit type, RC type, number of Indoor units connected.)
- Check Indoor unit type and RC type of all Indoor units connected to Network Converter.

↓ OK

Cause 6 : Defective PCB of Indoor unit or Network Converter.

- ▶ **Replace PCB of Controller PCB or Network Converter.**

Trouble shooting 72

Error Contents :
Communication Error with Indoor Unit

Symptom :
Error Code display [2 6]
All the control items do not operate.

Details :

Condition of occurrence : The communication between Indoor unit and Network Converter was not performed normally.

Release condition : When the communication with Indoor unit is resumed normally.

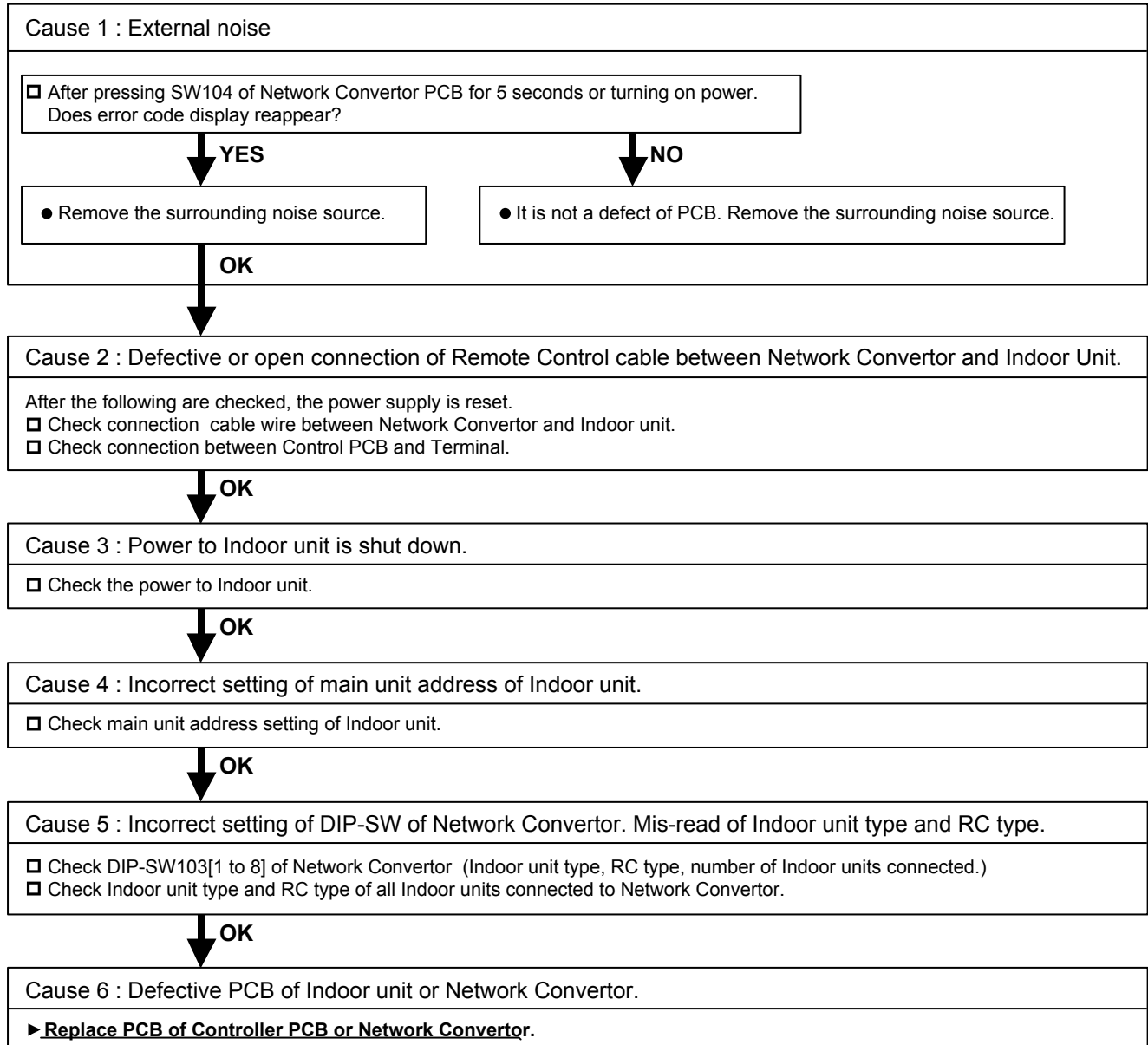

Trouble shooting 73

Error Contents :
Software Error

Symptom :
Error Code display [C A]
All the control items do not operate.
Other Controls are left they are.

Details :

Condition of occurrence : Micon program performed an abnormal control.
 Error of inside information of EEPROM.
 initial setting of Network Converter PCB was not normally performed.
 Release condition : Micon has been reset, and the control of Network Converter became normal.
 When error disappeared and Network Converter becomes available to control.

Cause 1 : External noise

Check continuation of error.
 (1) If error is released automatically, it is not a defect of PCB. Remove the surrounding noise source around Network Converter.
 (2) If error is not released automatically, check followings.

↓ OK

After pressing SW104 of Network Converter PCB for 5 seconds or turning on power.
 Does error code display reappear?

↓ YES

↓ NO

● Remove the surrounding noise source.

● It is not a defect of PCB. Remove the surrounding noise source.

↓ OK

Cause 2 : Network Converter is defective.

▶ **Replace Network Converter.**

Trouble shooting 74

Error Contents :
Indoor / Outdoor Unit Error

Symptom :
Error Code display [5 U]
Other controls are left as they are.

Details :

Condition of occurrence : When error occurred on Indoor/Outdoor unit that is connected to Network Converter.
 Release condition : When the error of Indoor/Outdoor unit that is connected to Network Converter is released.

Cause 1 : Error occurred in Indoor unit

▶ **Refer to Indoor Unit trouble shooting.**
 (Removal of error of indoor unit connected to network converter)

↓ OK

Cause 2 : Error occurred in Outdoor unit

▶ **Refer to Outdoor Unit trouble shooting.**
 (Removal of error of outdoor unit connected to network converter)

4. Group Remote Controller (UTY-CGGY / CGGG)

Trouble shooting 75

Error Contents :
PCB Error

Symptom :
Error Code display [C 4]
OPERATION LED is flashing.

Details :

Condition of occurrence : When EEPROM can not be written, or the control port does not operate.
Release condition : Power is reset.

Cause 1 : Remote Controller is defective.

► **Replace Group Remote Controller.**

Trouble shooting 76

Error Contents :
Connection Error

Symptom :
Error Code display [1 2]
OPERATION LED is flashing.

Details :

Condition of occurrence : The valid signal has not been received from the convertor more than 90 seconds after the communication line became valid.
Release condition : Valid signal is received from Converter.

Cause 1 : Connection failure

- Check power to the convertor.
- Check connection of remote control line between controller and convertor.



Cause 2 : Check outside cause (Voltage drop or noise, etc.)

- Instant drop ----- Check if there is a large load electric apparatus in the same circuit.
- Momentary power failure ----- Check if there is a defective contact or leak current in the power supply circuit.
- Noise ----- Check if there is any equipment causing harmonic wave near electric line (Neon bulb or electric equipment that may cause harmonic wave).



Cause 3 : Remote Controller is defective.

- ▶ **Replace Group Remote Controller.**

Trouble shooting 77

Error Contents :
Address Setting Error

Symptom :
Error Code display [2 6]
OPERATION LED is flashing.

Details :

Condition of occurrence :

1. No Indoor unit is registered.

Release condition :

1. The key to enter the function selection process is pressed.
TIME< key and TIME> key are simultaneously kept pressed.
2. It automatically initializes by itself. After that, it is released by pressing the key to enter the function selection process.

Cause 1 : Setting failure

- Register Indoor units again by entering to the function selection mode.
(Keep pressing TIME< key and TIME> key.
(Refer to the installation manual for the remote controller.)

Trouble shooting 78

Error Contents :
System Error

Symptom :
Error Code display [1 5]
OPERATION LED is flashing.

Details :

Condition of occurrence :

1. Registration started within 4 minutes after power ON
2. Indoor unit refrigerant system registered at controller connected to converter reached 3 or more ([26] error generated at converter)
3. Only the slave unit is registered. (Main unit is not registered.)
4. Indoor unit which is not existing was registered.
5. Outdoor unit is not set in the same refrigerant circuit as the indoor unit.

Release condition :

Registered contents have been changed by SELECT key, DAY key, Timer Mode key (DELETE key).

Cause 1 : Conditions check

- Check if 4 minutes or more after starting
- Clear when [26] error generated at converter.
- Check if refrigerant systems do not become 3 or more by this indoor unit registration.



Cause 2 : Setting failure

- Recheck the registered contents.(Register the main unit.)
- Check Indoor unit DIP-SW, R-SW
- Check outdoor unit R-SW.



Cause 3 : Connection failure

- Check transmission cable
- Check if Indoor or Outdoor unit power line is disconnected.
- Check if the convertor power line is disconnected.
- Check connection between controller and the convertor.



Cause 4 : Check outside cause (Voltage drop or noise, etc.)

- Instant drop ----- Check if there is a large load electric apparatus in the same circuit.
- Momentary power failure ----- Check if there is a defective contact or leak current in the power supply circuit.
- Noise ----- Check if there is any equipment causing harmonic wave near electric line (Neon bulb or electric equipment that may cause harmonic wave).



Cause 5 : Remote Controller is defective.

- ▶ **Replace Group Remote Controller.**

Trouble shooting 79

Error Contents :
Transmission Error

Symptom :
Error Code display [1 4]
OPERATION LED is flashing.

Details :

Condition of occurrence : When the signal is cut off for more than 10 minutes from the registered Indoor unit (not including Slave unit).

Release condition : 1. The signal has been received from the Indoor units that was creating the error.
2. MPU has been booted up. (Release from the reset operation, the power failure stand-by operation.)

Cause 1 : Connection failure

- Check transmission cable
- Check disconnected power line for Indoor unit.
- Check if convertor power line is disconnected.



Cause 2 : Check outside cause (Voltage drop or noise, etc.)

- Instant drop ----- Check if there is a large load electric apparatus in the same circuit.
- Momentary power failure ----- Check if there is a defective contact or leak current in the power supply circuit.
- Noise ----- Check if there is any equipment causing harmonic wave near electric line (Neon bulb or electric equipment that may cause harmonic wave).



Cause 3 : Remote Controller is defective.

- ▶ **Replace Group Remote Controller.**

5. Wired Remote Controller (UTY-RNK*)

Trouble shooting 80

Error Contents :
Thermo Sensor Error

Symptom :
Thermostat Sensor display is flashing.

Details :

Condition of occurrence : Thermistor in remote controller is open or shorted.

Release condition : Thermistor in remote controller is not open or shorted.

Cause 1 : Remote controller internal thermistor trouble

Replace remote controller.

6. Wired (UTY-RNK*) and Simple Remote Controller (UTY-RSK*,RHK*)

Trouble shooting 81

Error Contents :
Indoor Unit ↔ Remote Controller
Communication Error

Symptom :
Error Code display [1 2]

Details :

Condition of occurrence : When signal from indoor unit does not enter
Release condition : When signal from indoor unit entered

Cause 1 : Check connection

- Check cable
- Check indoor unit power supply



Cause 2 : Check indoor unit remote controller address.

- Check if the indoor unit remote controller addresses are sequentially set from 0.



Cause 3 : Noise

- Remove the surrounding noise.



Cause 4 : Remote controller trouble

- Replace remote controller.



Cause 5 : Indoor unit PCB trouble

- Change Controller PCB and set up the original address.

Trouble shooting 82

Error Contents :
Incompatible Indoor Unit is Connected

Symptom :
Error Code display [1 5]

Details :

Condition of occurrence : When information was not obtained from indoor unit
Release condition : When information was obtained from indoor unit

Cause 1 : Check remote controller master/slave setting.

- For the check and modification methods, refer to the remote controller (including external SW) installation manual.
- When there is 1 remote controller, check whether or not it is set as the master remote controller.
- When there are 2 remote controllers, check if one side is the master remote controller and the other side is the slave remote controller.
- When there are 1 remote controller and 1 external switch controller, check if the remote controller is master controller and the external switch controller is slave controller.



Cause 2 : Check connection

- Check cable
- Check indoor unit power supply



Cause 3 : Noise

- Source around cable



Cause 4 : Remote controller trouble

- Replace remote controller.



Cause 5 : Indoor unit PCB trouble

- Change Controller PCB and set up the original address.

7. System Controller (UTY-APGX) / Service Tool (UTY-ASGX) / Web Monitoring Tool (UTY-AMGX)
(Referred to as "Service Tool" hereafter)

Trouble shooting 83

Error Contents :
Unit Not Detected

Symptom :
1 or more units (but not all) are not detected after Scan.
1 or more units (but not all) are not listed in the system list after Scan.

Details :

Condition of occurrence:

- Unit address is not set correctly.
- Network cable is not connected correctly.
- System design is mistaken.
- Unit transmission board is defective.

Recovery condition:

- Unit address is set correctly.
- Network cable is connected as designed.
- System design and work is corrected.
- Unit transmission board is normal.

Cause 1 : Unit address is not set correctly.

- Check the unit address setting of the undetected unit and correct it if mistaken.



Cause 2 : Network cable is not connected as designed.

- Check that the network cables are connected according to the site design drawing.
Check specifically the network segment where the undetected unit exists.
- Check and fix the loose cable connection to the terminal of the undetected unit.
- Using Service Tool, perform scan changing the network segment where the Service Tool is connected and localize the mistaken network segment. Start from the network segment where the undetected unit exists.
Specify priority scan when possible.



Cause 3 : System design work is mistaken.

- Check the following items and fix appropriately if mistaken.
 - (1) 1 (and only 1) Terminal Resistor is connected for each network segment.
 - (2) Cable length is within 500m for each network segment.
 - (3) Number of units connected within a network segment does not exceed 64.
(1 connected port of Signal Amplifier is counted as 1).
 - (4) Network cable specification is as specified in the Design & Technical Document.
 - (5) Total number of Signal Amplifiers does not exceed 8 per system.
 - (6) Network cable is not connected in loop.
 - (7) Both ends of the network cable are grounded.
 - (8) Network cables are not bundled together with power cables to prevent noise induction.



Cause 4 : Unit transmission board is defective.

- Replace transmission board of the undetected unit if none of the above cause applies.

Note :

A Network Segment is a portion of the network connected directly by network cables and is separated by Signal Amplifiers. If no Signal Amplifier exists, there is only 1 network segment.

Trouble shooting 100 INDOOR UNIT Error Method: Indoor Unit power supply error for FAN motor 1 (2)	Indicate or Display: Outdoor Unit : E.5 U.1 Error Code : 3 9 , 3 9 . 1 (2)
--	---

Detective Actuators: Indoor Unit Controller PCB Circuit Indoor Unit filter PCB Circuit	Detective details: When the DC power input for Fan motor < W500 - W501 (W530 - W531) on the Filter PCB> becomes lower voltage than the specified voltage.
---	---

Forecast of Cause :	1. Noise momentary open, voltage drop 4. Peripheral electric devices	2. Wire connection 5. Filter PCB	3. Fan motor 6. Controller PCB
----------------------------	---	-------------------------------------	-----------------------------------

Check Point 1 : Check if any outside cause such as voltage drop or noise <ul style="list-style-type: none"> ● Instant voltage drop ----- Check if there is any electric equipment with a large load within the same circuit. ● Momentary power failure ----- Check contact failure or leak current in power supply circuit ● Check if there is any equipment that causes harmonic wave near the power cable (Neon light bulb or any electronic equipment which causes harmonic wave). And check the complete insulation of grounding. <p>>>If the same symptom does not reappear after resetting the power, possibility of noise is high.</p>



Check Point 2 : Check wire connection <input type="checkbox"/> Wire lose connection / damage between the CN21on the Controller PCB and CN250 on the Filter PCB In case of Model 72, between W530 (W531) on the filter PCB and capacitor. >>If there is abnormal on the wire, replace it
--



Check Point 3 : Check rotation of Fan / wire resistance <input type="checkbox"/> Rotate the applicable fan by hand when operation is off. <input type="checkbox"/> Disconnect the connector from the controller PCB and Check resistance value of Motor connector (Refer to the service parts information 13-2)



Check Point 4 : Check peripheral devices, Posistor, Capacitor, Diode bridge <input type="checkbox"/> Check resistance value, short circuit, visible damage >>If there is abnormal , replace it
--



Check Point 5 : Replace Filter PCB <input type="checkbox"/> Change filter PCB



Check Point 6 : Replace Controller PCB <input type="checkbox"/> Change Controller PCB and set up the original address.
--

Trouble shooting 101 INDOOR UNIT Error Method: Indoor unit suction air temp. thermistor error	Indicate or Display: Outdoor Unit : E.5 U.1 Error Code : 4 A, 4 A. 1
---	---

Detective Actuators: Indoor Unit Controller PCB Circuit Suction air temp. Sensor	Detective details: When Indoor unit suction air temp. thermistor open or shortage is detected
---	---

Forecast of Cause : 1. Connector defective connection 2. Thermistor defective 3. Controller PCB defective

<p>Check Point 1 : Check connection of Connector</p> <ul style="list-style-type: none"> <input type="checkbox"/> Check if connector is loose or removed <input type="checkbox"/> Check erroneous connection <input type="checkbox"/> Check if thermistor cable is open <p>>>Reset Power when reinstalling due to removed connector or incorrect wiring.</p>
--



Check Point 2 : Remove connector and check sensor resistance value									
Sensor Characteristics (Rough value)									
Temperature (°F)	32	41	50	59	68	77	86	95	
Temperature (°C)	0	5	10	15	20	25	30	35	
Resistance Value (kΩ)	33.6	25.2	20.1	15.8	12.5	10.0	8.0	6.5	
Temperature (°F)	104	113	122						
Temperature (°C)	40	45	50						
Resistance Value (kΩ)	5.3	4.3	3.5						
<p>▶ If Thermistor is either open or shorted, replace it and reset the power.</p>									



Check Point 3 : Check voltage CN9 of Controller PCB (DC5.0V)
▶ If the voltage does not appear, replace Controller PCB and set up the original address.



Trouble shooting 102 INDOOR UNIT Error Method: Indoor unit discharge air temp. thermistor error	Indicate or Display: Outdoor Unit : E.5 U.1 Error Code : 4 A, 4 A. 2
---	---

Detective Actuators: Indoor Unit Controller PCB Circuit Discharge air temp. Sensor	Detective details: When Indoor unit discharge air temp. thermistor open or shortage is detected
---	---

Forecast of Cause : 1. Connector defective connection 2. thermistor defective 3. Controller PCB defective

Check Point 1 : Check connection of Connector <input type="checkbox"/> Check if connector is loose or removed <input type="checkbox"/> Check erroneous connection <input type="checkbox"/> Check if thermistor cable is open >>Reset Power when reinstalling due to removed connector or incorrect wiring.

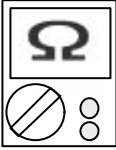

Check Point 2 : Remove connector and check sensor resistance value									
Sensor Characteristics (Rough value)									
Temperature (°F)	32	41	50	59	68	77	86	95	
Temperature (°C)	0	5	10	15	20	25	30	35	
Resistance Value (kΩ)	33.6	25.2	20.1	15.8	12.5	10.0	8.0	6.5	
Temperature (°F)	104	113	122						
Temperature (°C)	40	45	50						
Resistance Value (kΩ)	5.3	4.3	3.5						
► If Thermistor is either open or shorted, replace it and reset the power.									



Check Point 3 : Check voltage CN9 of Controller PCB (DC5.0V)
► If the voltage does not appear, replace Controller PCB and set up the original address.



Trouble shooting 103 INDOOR UNIT Error Method: Indoor Unit Fan Motor 2 rotation speed Error	Indicate or Display: Outdoor Unit : E.5 U.1 Error Code : 59, 59.2
--	--

Detective Actuators: Indoor Unit Controller PCB Circuit Indoor Fan Motor 2	Detective details: When the FAN motor feed back rotation value which is detecting on the controller PCB becomes 0 and lasts for more than 1 minute at motor operation condition. Or, when the feed back rotation value continues at 1/3 of target value for more than 1 minute.
---	--

Forecast of Cause : 1. Fan rotation failure 2. Fan motor winding open 3. Motor protection by ambient temp. increase 4. Capacitor failure 5. Controller PCB failure
--

Check Point 1 : Check rotation of Fan

Rotate the fan by hand when operation is off.
 (Check if fan is caught, dropped off or locked motor)
>>If Fan or Bearing is abnormal, replace it.



Check Point 2 : Check Motor winding / Internal PCB circuit

Check Indoor Fan motor (Refer to the PARTS INFORMATION 13-2)
>>If Fan motor is abnormal, replace it.



Check Point 3 : Check ambient temp. around motor

Check excessively high temperature around the motor.
 (If there is any surrounding equipment that causes heat)
>>Upon the temperature coming down, restart operation..



Check Point 4 : Check Motor Capacitor

Check continuity of motor capacitor
>>If it is shorted, replace the capacitor.



Check Point 5 : Replace Controller PCB

Change Controller PCB and set up the original address.



Trouble shooting 104

Outdoor air unit - No Power

Forecast of Cause :

1. Power Supply failure
2. Outside cause
3. Electrical Component defective

Check Point 1 : Power supply

- Is not the breaker down?
 - Instant drop ----- Check if there is a large load electric apparatus in the same circuit.
 - Momentary power failure ----- Check if there is a defective contact or leak current in the power supply circuit.
 - Noise ----- Check if there is any equipment causing harmonic wave near electric line (Neon bulb or electric equipment that may cause harmonic wave).
Check the complete insulation of grounding.

↓ **OK**

Check Point 2 : Check Protector (20A)

- Check protector open / short
If the protector is open circuit, replace it.

↓ **OK (No short circuit)**

Check Point 3 : Check AC line

- Check AC line (L-N) open / short

↓ **NG (Short circuit)**

Check Point 4 : Check short circuit Filter PCB

- Disconnect the wire between Filter PCB and reactor, check short circuit of AC line.
If there is short circuit, replace the Filter PCB.

↓ **OK (No short circuit)**

Check Point 5 : Check short circuit Diode bridge

- Connect the disconnected wire(s) on the check point 4, disconnect the wire between Diode bridge and Capacitor, check short circuit of AC line.
If there is short circuit, replace the Diode bridge.

↓ **OK (No short circuit)**

Check Point 6 : Check short circuit Capacitor

- Connect the disconnected wire(s) on the check point 5, disconnect the wire between Capacitor and Filter PCB, check short circuit of AC line.
If there is short circuit, replace the Capacitor.

↓ **OK (No short circuit)**

Check Point 7 : Check short circuit Power supply PCB

- Connect the disconnected wire(s) on the check point 6, disconnect the wire of Fan motor, check short circuit of AC line.
If there is short circuit, replace the Power supply PCB.

↓ **OK (No short circuit)**

Check Point 8 : Check Fan Motor

- Check open / short of FAN motor
Refer to the Service Parts Information 13-2
If there is short circuit, replace FAN motor.

↓ **OK (No short circuit)**

Check Point 9 : Short circuit check on DC circuit

Disconnect the connector (CN200) on the Power supply PCB and check the short circuit

1. DC12V line (CN200 Pin 1 - 5)
2. DC 5V Line (CN200 Pin 1 - 3)
3. DC 15V-1 Line (CN500 Pin 3 - 4)
4. DC 15V-2 Line (CN530 Pin 3 - 4)

If one of them is short circuit, replace the Power supply PCB

↓ **OK (No short circuit)**

Check Point 10 : Check short circuit of actuators (for DC12V)

- Disconnect the CN10 (EEV1) on the Main PCB, and check short circuit on Main PCB CN 4 Pin 1 - 5.
If the short circuit disappears, replace the EEV coil.
- Disconnect the CNC01 (WRC) on the Main PCB, and check short circuit on Main PCB CN 4 Pin 1 - 5.
If the short circuit disappears, check the WRC wire, WRC.
- Disconnect the CNB01 (Ext.Out) on the Main PCB, and check short circuit on Main PCB CN 4 Pin 1 - 5.
If the short circuit disappears, check the Ext. device or wiring.
- Disconnect the CN2 (TransmissionPCB) on the Main PCB, and check short circuit on Main PCB CN 4 Pin 1 - 5.
If the short circuit disappears, replace the Transmission PCB.
- Disconnect the CN22 (Interconnecting wire) on the Main PCB, and check short circuit on Main PCB CN 4 Pin 1 - 5.
If the short circuit disappears, replace the Filter PCB.
- If the short circuit appears after disconnecting actuators, replace the Main PCB.

↓ **OK (No short circuit)**

Check Point 11 : Check short circuit of actuators (for DC5V)

- Disconnect the CN14 (SW PCB) on the Main PCB, and check short circuit on Main PCB CN 4 Pin 1 - 3.
If the short circuit disappears, replace the SW PCB.
- Disconnect the CN18 (Receiver unit *Option) on the Main PCB, and check short circuit on Main PCB CN 4 Pin 1 - 3.
If the short circuit disappears, check the wire, Receiver unit.
- Disconnect the CN2 (Transmission PCB) on the Main PCB, and check short circuit on Main PCB CN 4 Pin 1 - 3.
If the short circuit disappears, replace the Transmission PCB.
- Disconnect the CN21 (Interconnecting wire) on the Main PCB, and check short circuit on Main PCB CN 4 Pin 1 - 3.
If the short circuit disappears, replace the Power supply PCB.
- If the short circuit appears after disconnecting actuators, replace the Main PCB.

Trouble shooting 105 INDOOR UNIT Error Method: Coil 1 (Expansion valve) Error	Indicate or Display: Outdoor Unit : E.5U.1 Indoor Unit : Operation LED 5 times Flash, Timer LED 2 Times Flash, Filter LED Continuous Flash. Error Code : 5 2
---	---

Detective Actuators: Indoor unit controller PCB	Detective details: When the EEV1 drive circuit is open circuit
---	--

Forecast of Cause :	1. Wrong capacity setting 2. EEV1 coil lose connection 3. EEV1 wire(s) cut or pinched 4. Defective EEV1 coil 5. Controller PCB (DC 12V) output abnormal 6. Noise momentary open, voltage drop
----------------------------	--

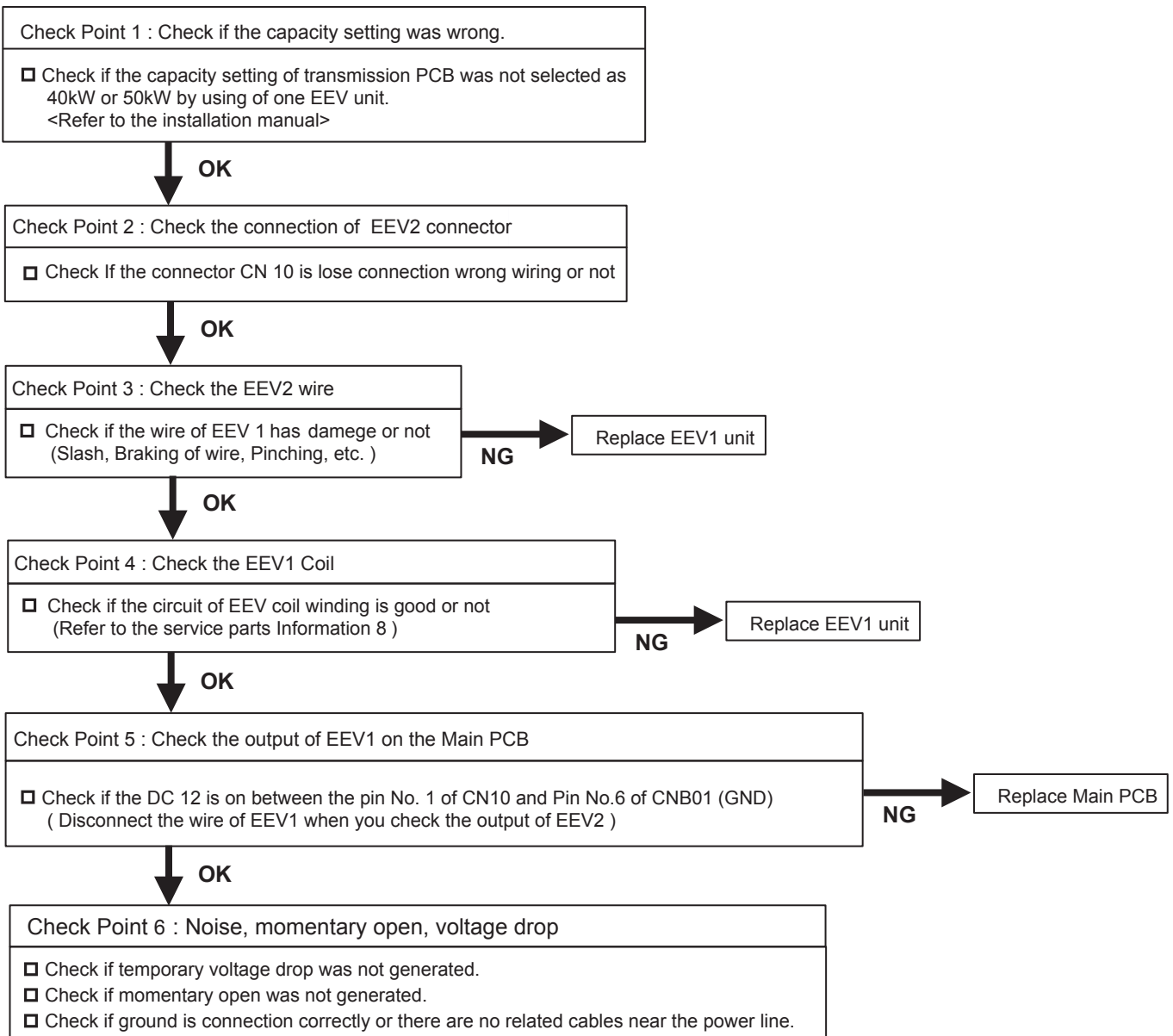

Trouble shooting 106 INDOOR UNIT Error Method: Coil 2 (Expansion valve) Error	Indicate or Display: Outdoor Unit : E.5U.1 Indoor Unit : Operation LED 5 times Flash, Timer LED 2 Times Flash, Filter LED Continuous Flash. Error Code : 5 2
---	---

Detective Actuators: Indoor unit controller PCB	Detective details: When the EEV2 drive circuit is open circuit
---	--

Forecast of Cause :	1. Wrong capacity setting 2. EEV2 coil lose connection 3. EEV2 wire(s) cut or pinched 4. Defective EEV2 coil 5. Controller PCB (DC 12V) output abnormal 6. Noise momentary open, voltage drop
----------------------------	--

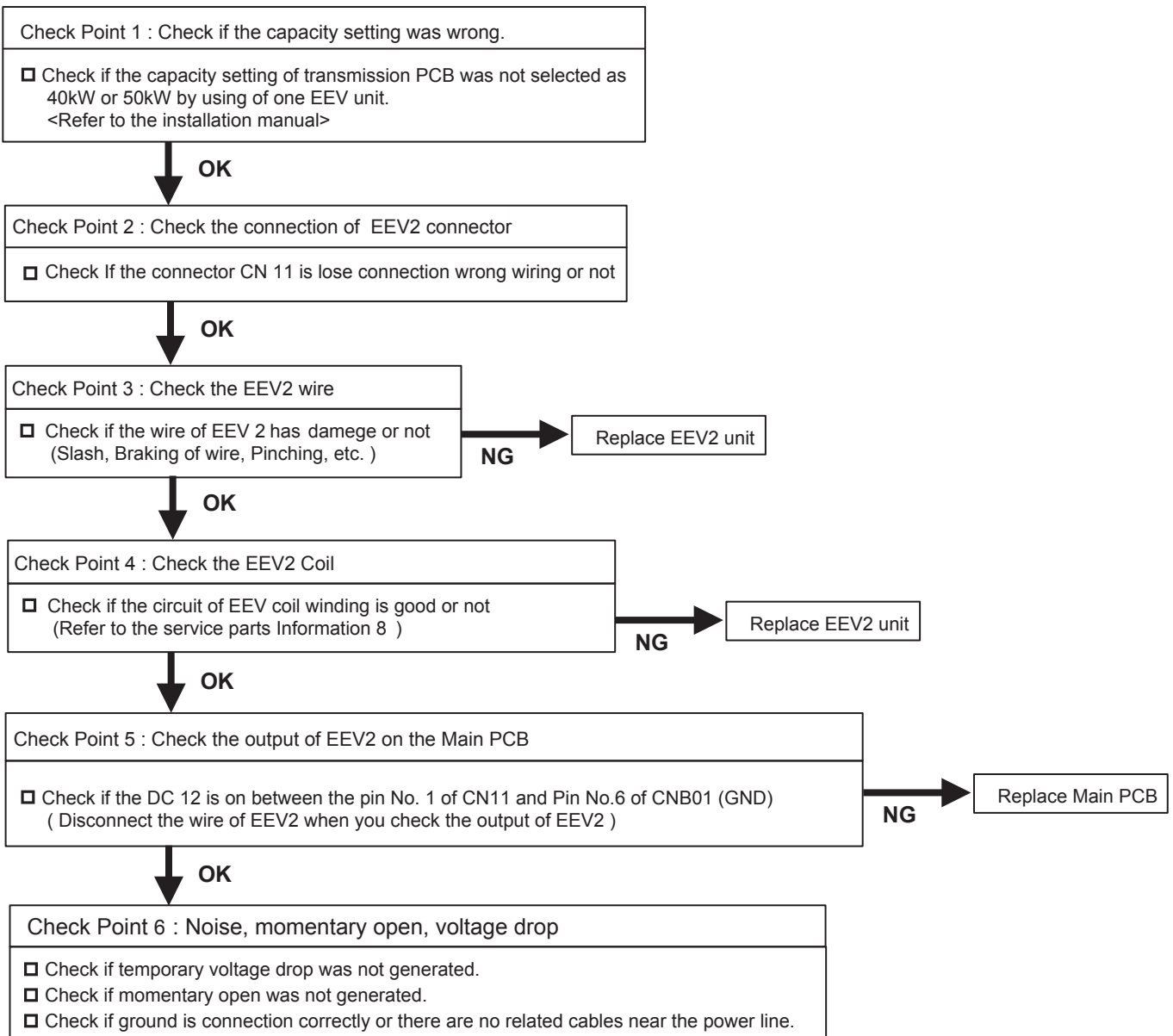

Trouble shooting 107 INDOOR UNIT Error Method: Peripheral device Error (DX-KIT Error)	Indicate or Display: Outdoor Unit : E.5U.1 Indoor Unit : Operation LED 13 times Flash, Timer LED 6 Times Flash, Filter LED Continuous Flash. Error Code : J 6
--	--

Detective Actuators: Peripheral device Error	Detective details: When the DX-KIT control unit received the Error input from Peripheral device Error
--	---

Forecast of Cause : 1. Error input connecting wire (When the External input Error input in use.) damage 2. Peripheral device Error

Check point 1: Check the wire connection of External input (Error input)
<input type="checkbox"/> Check wire between the terminal "Error input signal" of DX-KIT and the peripheral device, if it is not short circuit. If the connecting wire has the shorcircuit, replace the wire.

Check point 2: Check the Error status of peripheral device
<input type="checkbox"/> Refer to the Maintenance manual for the peripheral device.

* The type of error cannot be checked at the DX-KIT control unit.

Trouble shooting 108

Peripheral device doesn't operate
(No-power)

Forecast of Cause :

1. Power supply failuer
2. Trouble on peripheral device
3. DX-Kit Electrical component defective
4. Field setting mismatch

General check procedure

1. Check Error code on the VRF system. (Remote controller, Service tool, etc)
2. Check LED brinks on the contrler PCB of DX-KIT
3. Check Error code on the peripheral device.
4. Check non of wrong filed settings or wrong installation.

Check Point 1 : Power supply

□ Is not the breaker down?

Instant drop ----- Check if there is a large load electric apparatus in the same circuit.

Momentary power failure ----- Check if there is a defective contact or leak current in the power supply circuit.

Noise ----- Check if there is any equipment causing harmonic wave near electric line (Neon bulb or electric equipment that may cause harmonic wave).

Check the complete insulation of grounding.

OK

Check Point 2: LED indication on the controller PCB

LED Brinking

Check Error code indication on the remote controller or Service tool

LED ON

Check Point 3: Operation signal output

Check circuit on the terminal ON /OFF SIGNAL(OUTPUT)

Short circuit

Refer to the service manual for the peripheral device and check the trouble shooting tips.

Open circuit

Check Point 4: Relay PCB power input DC12V

Check power input CN800 Pin1 - Pin2

OK (DC12V)

Make sure that the operation command (ON signal) is transferring from the controller to the DX-Kit controller.
If the ON singal was OK, Replace the Relay PCB.

NG

Make sure that the operation command (ON signal) is transferring from the Controller to the DX-Kit controller.
If the ON singal was OK, Replace the Main PCB.

Other tips

Check Field function setting, (External input signal setting)
The Prohibit setting condions
The operating mode mismatch

Trouble shooting 109

Peripheral device FAN does not operate

Forecast of Cause :

1. Power supply failuer
2. Trouble on peripheral device
3. DX-Kit Electrical component defective
4. Field setting mismatch

General check procedure

1. Check Error code on the VRF system. (Remote controller, Service tool, etc)
2. Check LED brinks on the controller PCB of DX-KIT
3. Check Error code on the peripheral device.
4. Check non of wrong filed settings or wrong installation.
5. Check if FAN operation stopped by the freeze prevention or the defrosting operation.

Check Point 1 : Power supply

- Is not the breaker down?
Instant drop ----- Check if there is a large load electric apparatus in the same circuit.
Momentary power failure ----- Check if there is a defective contact or leak current in the power supply circuit.
Noise ----- Check if there is any equipment causing harmonic wave near electric line (Neon bulb or electric equipment that may cause harmonic wave).
Check the complete insulation of grounding.

OK

Check Point 2: LED indication on the controller PCB

LED Brinking

Check Error code indication on the remote controller or Service tool

LED ON

Check Point 3: Operation signal output

Check circuit on the terminal ON /OFF SIGNAL (OUTPUT)

Open circuit

Short circuit

Check Point 4: FAN SIGNAL output

Check circuit on the terminal FAN SIGNAL (OUTPUT)

Short circuit

Refer to the service manual for the prepheral device and check the trouble shooting tips.

Open circuit

Check Point 4: Relay PCB pwer input DC12V

Check power input CN800 Pin1 - Pin2

OK (DC12V)

Make sure that the operation command (ON signal) is transferring from the controller to the DX-Kit controller.
If the ON singal was OK, Replace the Relay PCB.

NG

Make sure that the operation command (ON signal) is transferring from the Controller to the DX-Kit controller.
If the ON singal was OK, Replace the Main PCB.

Other tips

Check Field function setting, (External input signal setting)
The Prohibit setting condtions
The operating mode mismatch

Trouble shooting 110

Peripheral device No Cooling / No Heating

Forecast of Cause :

1. Temperature controlling
2. EEV controlling
3. External Factor

General check procedure

1. Check Error code on the VRF system. (Remote controller, Service tool, etc)
2. Check LED brinks on the controler PCB of DX-KIT
3. Check Error code on the peripheral device.
4. Check none of protection function is operating on the system.
 - Protection functions (For the description of protective conditions, see the service manual.)
 - Abnormal Temperature: Compressor temperature, Discharge temperature, Heat-sink temperature, IDU HEX temp.
 - Abnormal pressure: High pressure, Low pressure,
 - Abnormal on devices: EEV coil, FAN motor, Compressor Frq,

Check Point 1: Temperature sensors

Sensor position / Wire connection / Temperature detection

- Measure the resistance of sensor at the terminal board, and compare the temperature (transformed with resistance value) with the actual detecting temperature by using the Service tool.

Gas / Liquid Sensor Characteristics (Rough value)

Temperature (°F)	32	41	50	59	68	77	86	95	104	113	122
Temperature (°C)	0	5	10	15	20	25	30	35	40	45	50
Resistance Value (kOhm)	33.6	25.2	20.1	15.8	12.5	10.0	8.0	6.5	5.3	4.3	3.5

Inlet / Outlet Air Sensor Characteristics (Rough value)

Temperature (°F)	32	41	50	59	68	77	86	95	104	113	122
Temperature (°C)	0	5	10	15	20	25	30	35	40	45	50
Resistance Value (kOhm)	168.6	129.8	100.9	79.1	62.5	49.8	40.0	32.4	26.3	21.2	17.8

- If the sensor position was incorrect, install the sensor to the correct position
- If the temperature detection was wrong, replace the sensor.

Check Point 2: EEV

Wire connection / EEV movment

- Measure the resistance of EEV coil and measure the DC12V power input at the terminal board.
 - EEV1: CN10_Pin No.1-Pin No.6, Pin No.1-Pin No.4, Pin No.2-Pin No.3, Pin No.2-Pin No.5)
 - EEV2: CN11_Pin No.1-Pin No.6, Pin No.1-Pin No.4, Pin No.2-Pin No.3, Pin No.2-Pin No.5)
- Check EEV initialisation movment by the power reset of DX-Kit.
- Check refrigerant flowing by measuring the temperature of pipe inlet and pipe outlet.

Read wire	Resistance value (20 °C)
White - Red	200 ± 10% Ω
Yellow - Brown	
Orange - Red	
Blue - Brown	

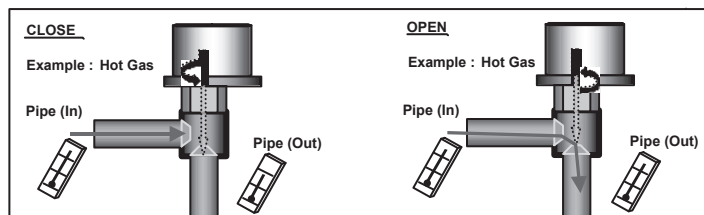

- If the resistance of EEV coil was not correct, replace the EEV unit.
- If the DC12V did not appear on the terminal, check DCV power supply on CN102.
- No Voltage: Replace the power supply PCB, DC12V appears: Replace the controller PCB.
- If the EEV did not react after power reset, or no refrigerant flowing, replace the EEV unit.

Check Point 3: External factor

- Air circulation obstruction
- Design mismatch (Capacity, FAN speed mismatch, Field setting (Analog signal input) etc,)
- Peripheral device abnormal (See the Service manual for the peripheral device)

Trouble shooting 111

DX-KIT Controller No Power
(LED on the Main PCB is OFF)

Forecast of Cause :

1. Power supply failuer
2. DX-Kit Electrical componrent defective

Check Point 1 : Power supply

□ Is not the breaker down?

Instant drop ----- Check if there is a large load electric apparatus in the same circuit.

Momentary power failure ----- Check if there is a defective contact or leak current in the power supply circuit.

Noise ----- Check if there is any equipment causing harmonic wave near electric line (Neon bulb or electric equipment that may cause harmonic wave).

Check the complete insulation of grounding.

OK

Check Point 2: FUSE F101 on the Power supply PCB

OPEN

Before replacing the burnt FUSE,
make sure that the terminal between
L-N -E are not short-circuit.

OK

Check Point 2: Output voltage on the power supply PCB

Disconnect the CN 102 on the Power supply PCB.

Check voltage CN102 output voltage

Pin No.1 - Pin No.6: DC12V

Pin No.2 - Pin No.6: DC5V

NG

Replace the Power supply PCB

OK

the condition of short-circuit, and

Check Point 2: Output voltage on the main PCB

Disconnect the CN 801, and the power input connectors
for actuators (EEV, Sensor, Relay PCB.)

Check voltage CN801 output voltage

Pin No.1 - Pin No.2: DC12V

NG

Replace the Main PCB

OK

Check Point 2: Output voltage on the main PCB

Disconnect the power input connectors for actuators
(EEV, Sensor, Relay PCB.)

And check the short circuit of each actuators.

NG

Replace the actuators which has the
Short-circuit conditions

4-4 SERVICE PARTS INFORMATION

SERVICE PARTS INFORMATION 1

Compressor

Diagnosis method of Compressor (If Outdoor Unit 7 segment LED displays Error, refer to Trouble shooting)

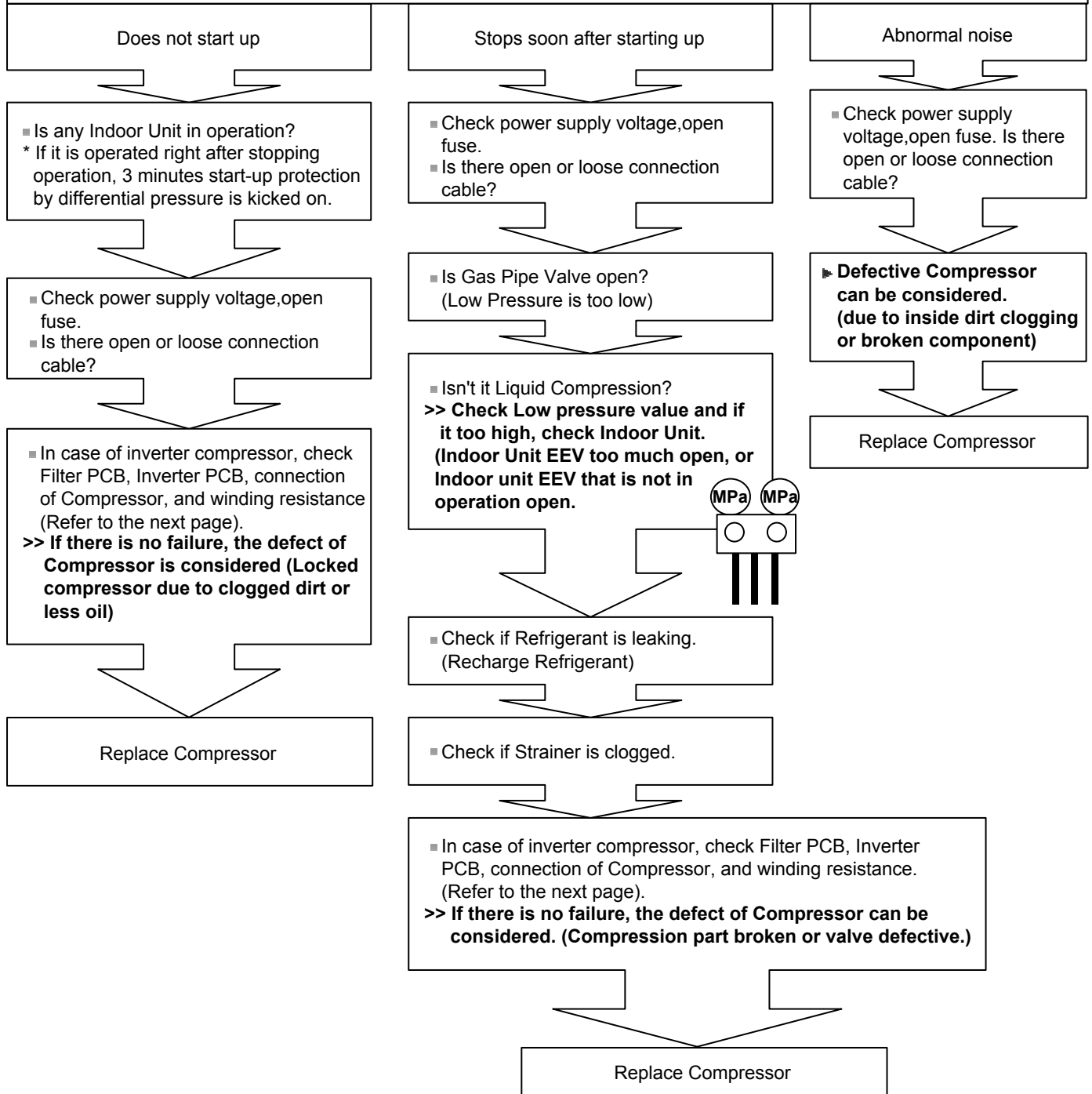

SERVICE PARTS INFORMATION 2

Inverter Compressor

Check Point 1 : Check Connection

- ❑ Check terminal connection of Compressor (loose or incorrect wiring)

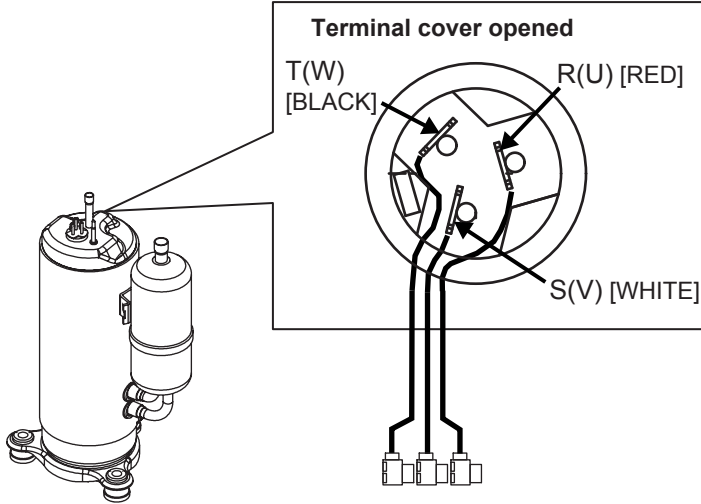

- ❑ Check connection of Inverter PCB (Loose or incorrect wiring)

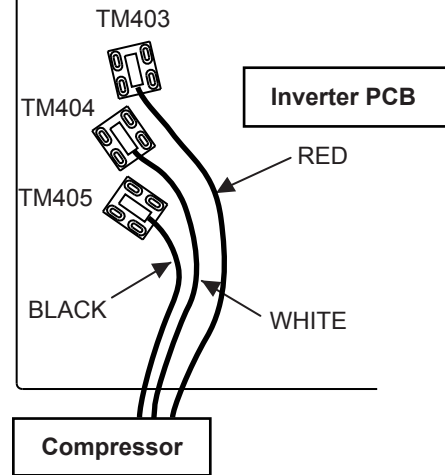

Check Point 2 : Check Winding Resistance

- ❑ Check winding resistance of each terminal
- ▶ **If the resistance value is 0Ω or infinite, replace Compressor.**

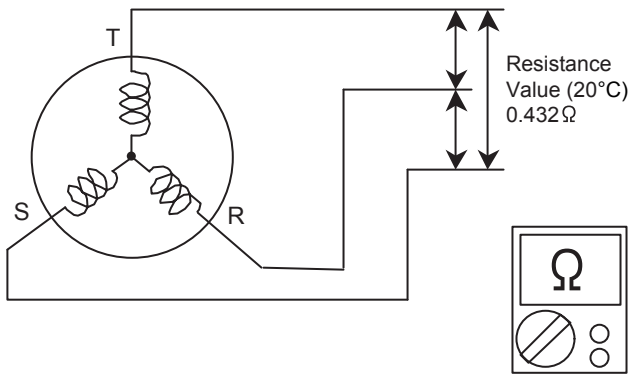

Attention!!

If Check 1, 2 are normal, make sure the following points.

- (1) Check AC voltage among each terminals from filter PCB(INV) to Diode Bridge. (Rated voltage among L and N).
▶ **If it does not appear, check the power supply terminal.**
 - (2) Check Voltage from Main PCB to Inverter PCB. (DC13.5 - 16.5V between terminals of CN126 (1-2) connector and DC (-12.0) - (-8.0)V between terminals of CN126 (3-2) connector of Main PCB).
▶ **If it does not appear, replace Main PCB.**
- ◆ **If both of above voltages appear, it is considered to be Inverter PCB circuit failure. Replace Inverter PCB and check operation.**



SERVICE PARTS INFORMATION 3

Main PCB
Filter PCB

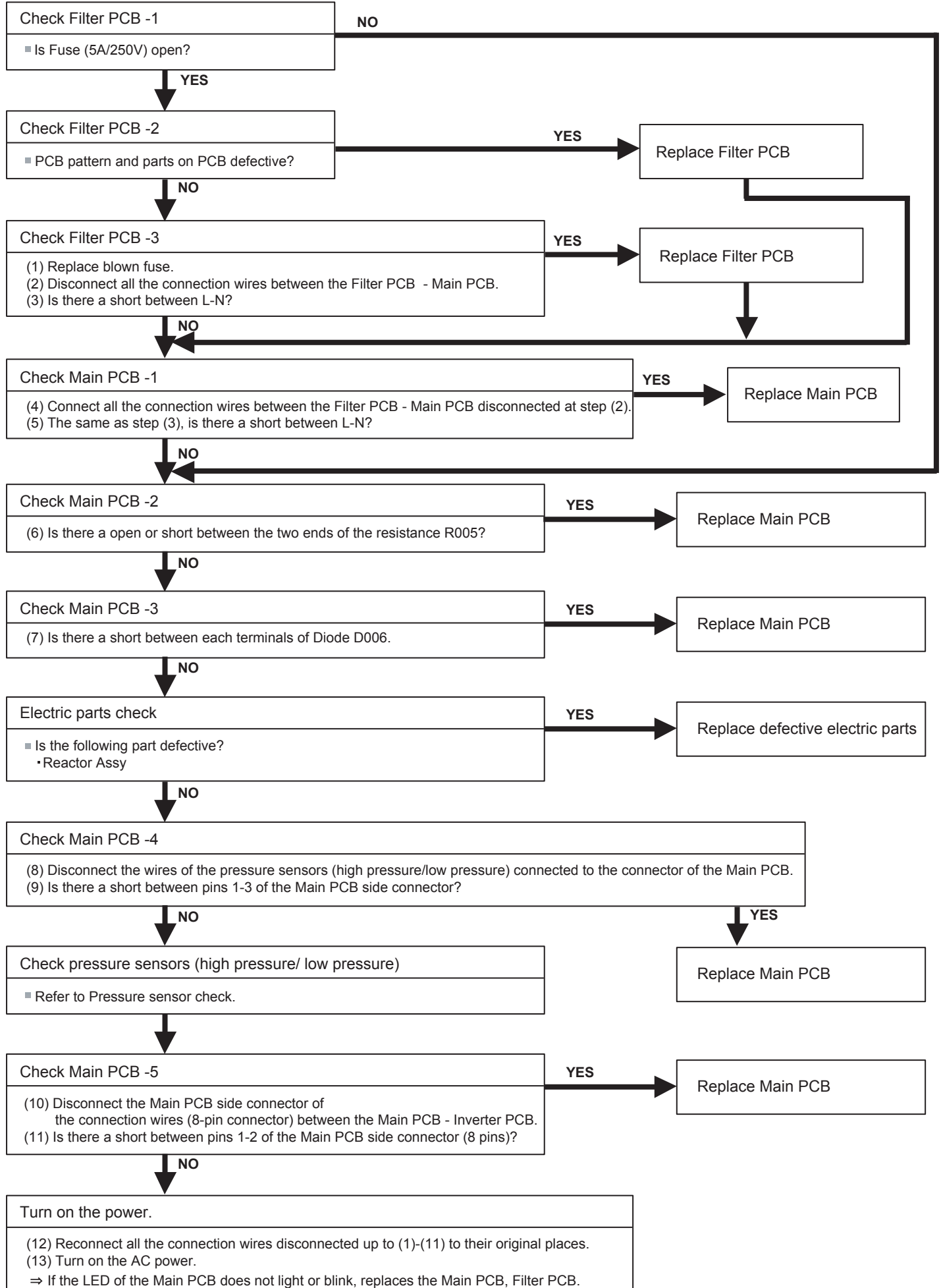

SERVICE PARTS INFORMATION 4

Inverter PCB Filter PCB

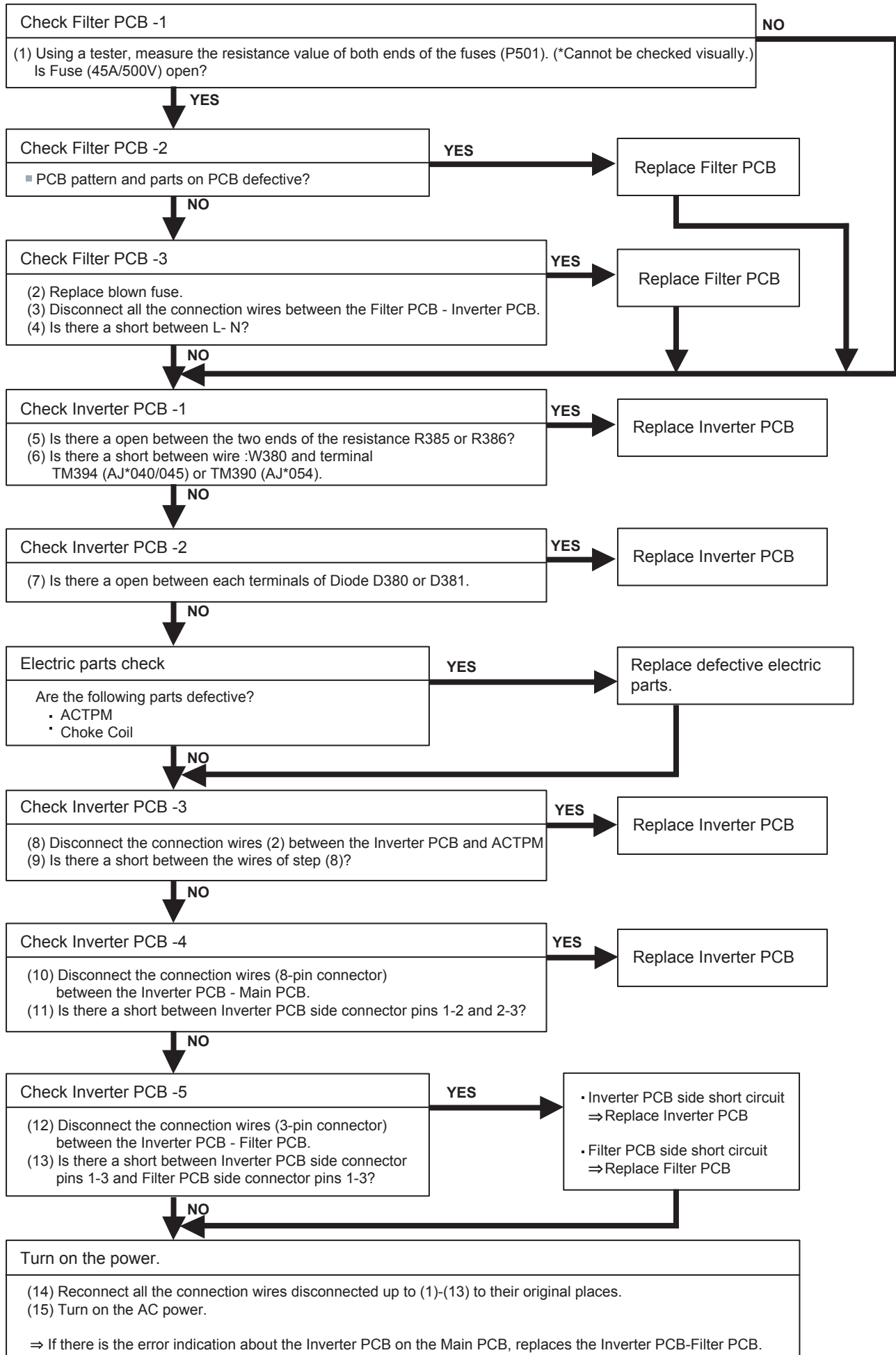

SERVICE PARTS INFORMATION 5

IPM
(Mounted on Inverter PCB)

Check Point 1

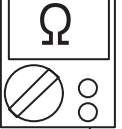

① Disconnect the connection wires between the Inverter PCB - ACTPM and Inverter PCB - Inverter Compressor.

② Set the tester to the "Resistance" mode, and measure the resistance between the following terminals.

Yellow wire (P) - Fasten terminals U/V/W
Blue wire (N) - Fasten terminals U/V/W

③ Judge the result of ② as follows:

All 6 points several MΩ or greater	: Normal
1 or more points several kΩ to short	: Defective

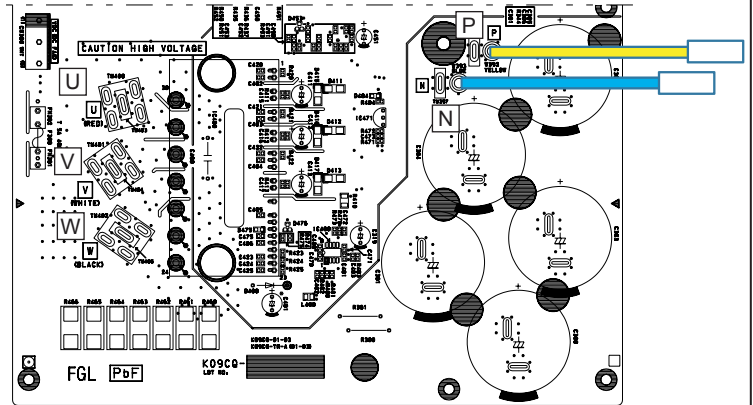

Inverter PCB

Check Point 2

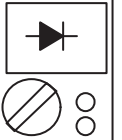

④ Set the tester to the "Diode" mode, and measure the voltage value between the following terminals.

Tester +side (red)	Tester - side (black)	Tester display [V]
Terminal U	Yellow wire (P)	
Terminal V		
Terminal W		
Blue wire (N)	Terminal U	
	Terminal V	
	Terminal W	

⑤ Judge the result of ④ as follows:

All 6 points several 0.3V to 0.7V	: Normal
1 or more points under 0.1V or over load	: Defective

SERVICE PARTS INFORMATION 6

Choke Coil (INV)
Reactor assy (DC Fan)

Check Point 1 : Appearance check

□ No fissures, breaks, damage, etc. at the body and winding section, terminals section?

Check Point 2 : Electric check

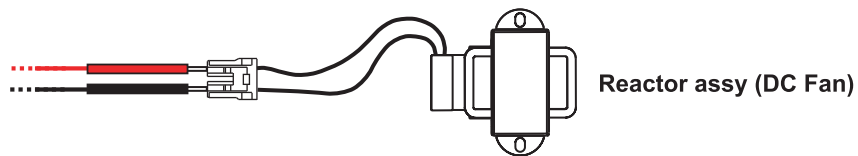
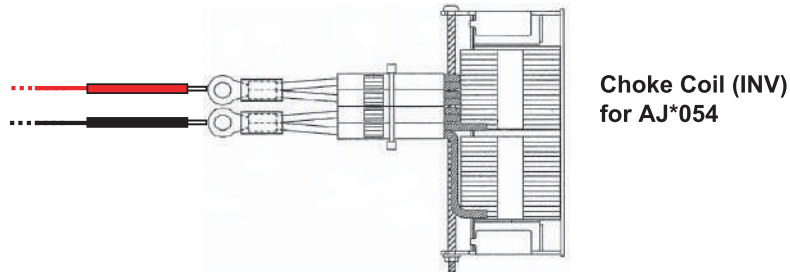
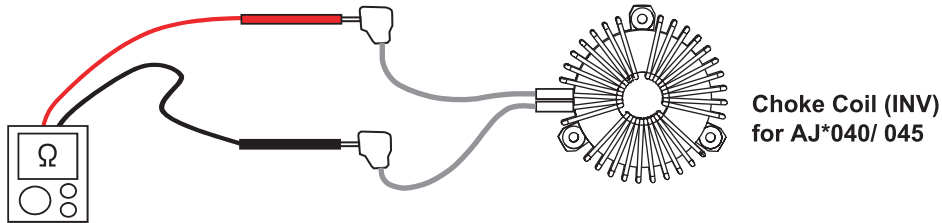

- ① Set the tester to the "Resistance" mode, and check for open/short between both ends of the reactor wire (or connector).
- ② Judge the result of ① as follows:

Short	Normal
Open	Abnormal (open)

SERVICE PARTS INFORMATION 7

Terminal

Check Point 1 : Appearance check

- No fissures, breaks, damage, etc. at the body and terminals section?
- Not clogged with foreign matter?
- Are there no abnormalities at threaded parts (Stripped threads, deformation, damage, etc.) ?

Check Point 2 : Electric check

- No short between adjacent terminals?
- Conducts before and after same terminal?



SERVICE PARTS INFORMATION 8-1

Indoor Unit Electronic Expansion Valve (EEV)

Check Point 1 : Check Connections

- ❑ Check Connectors (Loose connector or open cable.)

Duct

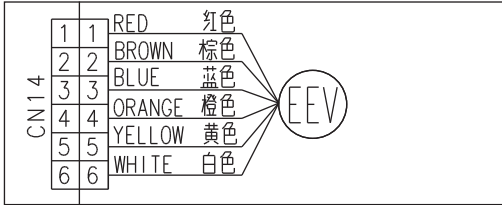

Small Wall mount

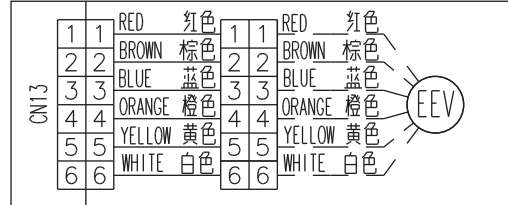

Floor/ Ceiling, Ceiling

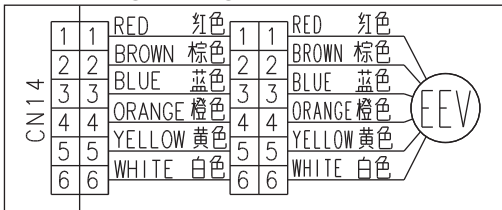

Cassette

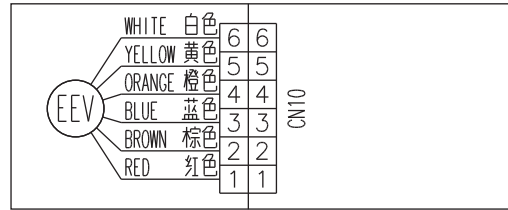

Wall mount

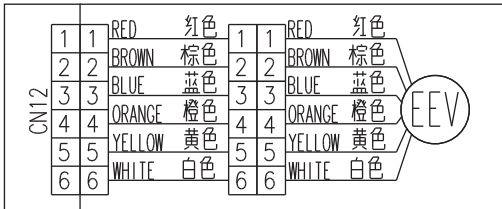

Check Point 2 : Check Coil of EEV

- ❑ Remove connector, check each winding resistance of Coil.

Read wire	Resistance value (20°C)
White - Red	200 ± 10% Ω
Yellow - Brown	
Orange - Red	
Blue - Brown	

- ▶ **If Resistance value is abnormal, replace EEV.**



Check Point 3 : Check Noise at start up

Turn on Power and check operation noise.

- >> **If an abnormal noise does not show, replace Controller PCB.**

Check Point 4 : Check Voltage from Controller PCB

- ❑ Remove Connector and check Voltage (DC12V).

- >> **If it does not appear, replace Controller PCB.**



Check Point 5 : Check Opening and Closing Operation of Valve

When Valve is closed,
it has a temp. difference between Inlet and Outlet.

If it is open,
it has no temp. difference between Inlet and Outlet.

CLOSE
Example : Hot Gas

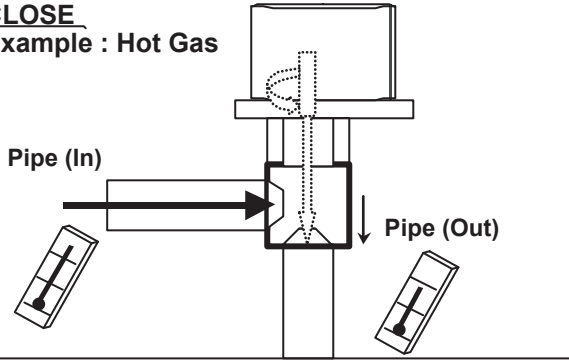

OPEN
Example : Hot Gas

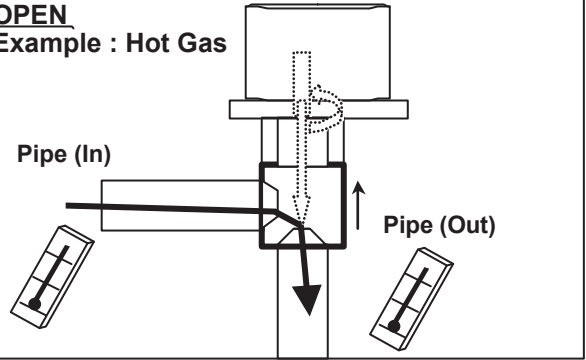

Check Point 6 : Check Strainer

Strainer normally does not have temperature difference between inlet and outlet as shown in (1), but if there is a difference as shown in (2), there is a possibility of inside clogged. In this case, replace Strainer.

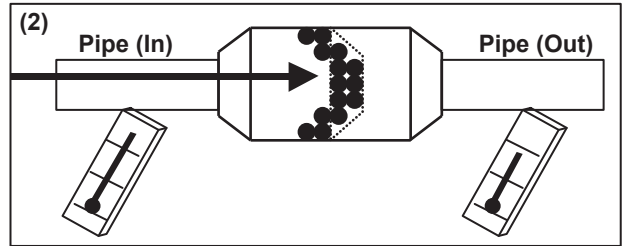
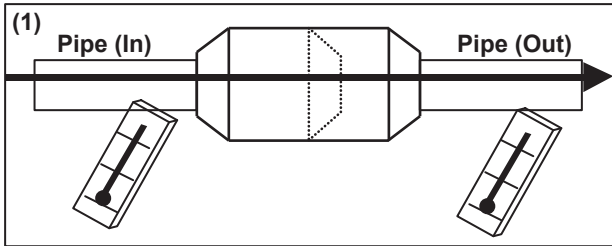

SERVICE PARTS INFORMATION 8-2

Indoor Unit Electronic Expansion Valve (EEV)

Check Point 1 : Check Connections

❑ Check Connectors (Loose connector or open cable.)

Cassette (AUXK018 - 030GLAH,
AUXM018 - 030GLAH
AUXN009 - 014GLAH)
Compact Floor (AG*A004 - 014GCAH)
Compact Wall mount (AS*A004 - 009GTAH)
Wall mount (AS*A030GTAH)

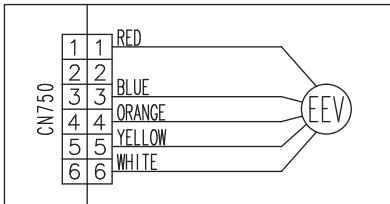

Compact Slim Duct (ARXK04 - 24GCLH)

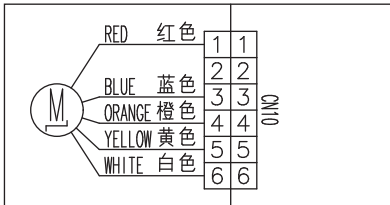

Check Point 2 : Check Coil of EEV

❑ Remove connector, check each winding resistance of Coil.

Lead wire	Resistance value (20°C)
White - Red	46 ± 10% Ω
Yellow - Red	
Orange - Red	
Blue - Red	

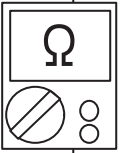

▶ **If Resistance value is abnormal, replace EEV.**

Check Point 3 : Check Noise at start up

Turn on Power and check operation noise.

>> **If an abnormal noise does not show, replace Controller PCB.**

Check Point 4 : Check Voltage from Controller PCB

❑ Remove Connector and check Voltage (DC12V).

>> **If it does not appear, replace Controller PCB.**



Check Point 5 : Check Opening and Closing Operation of Valve

When Valve is closed,
it has a temp. difference between Inlet and Outlet.

CLOSE
Example : Hot Gas

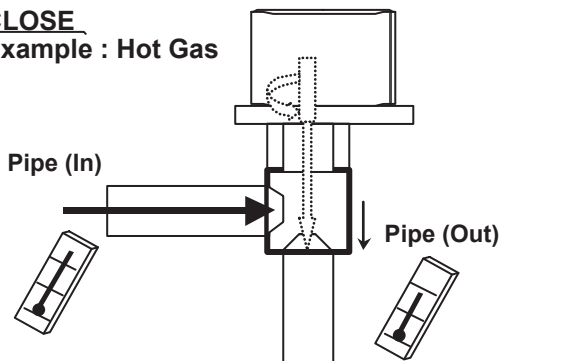

If it is open,
it has no temp. difference between Inlet and Outlet.

OPEN
Example : Hot Gas

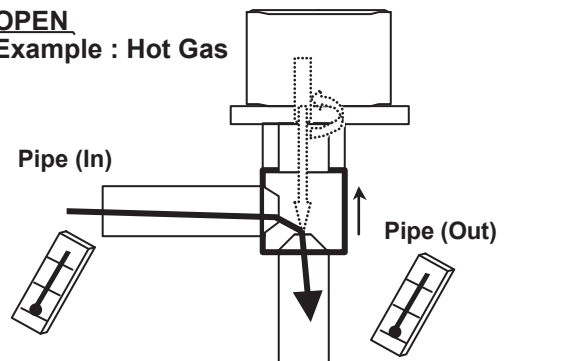

Check Point 6 : Check Strainer

Strainer normally does not have temperature difference between inlet and outlet as shown in (1), but if there is a difference as shown in (2), there is a possibility of inside clogged. In this case, replace Strainer.

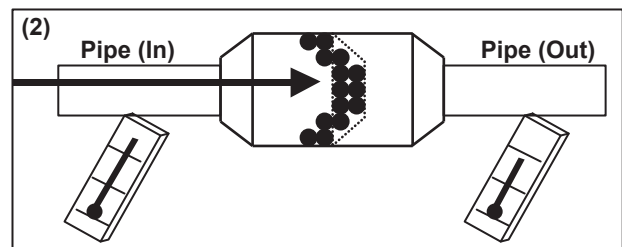
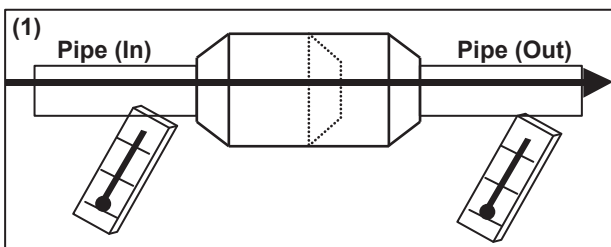

SERVICE PARTS INFORMATION 8-3

Indoor Unit Electronic Expansion Valve (EEV)

Check Point 1 : Check Connections

- ❑ Check Connectors (Loose connector or open cable.)

**Cassette (AUXK034 - 054GLAH)
Wall mount (AS*A034GTAH)**

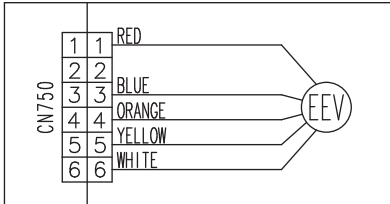

Check Point 2 : Check Coil of EEV

- ❑ Remove connector, check each winding resistance of Coil.

Read wire	Resistance value (20°C)
White - Red	150 ± 10% Ω
Yellow - Red	
Orange - Red	
Blue - Red	

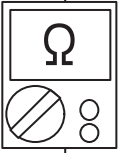

- ▶ **If Resistance value is abnormal, replace EEV.**

Check Point 3 : Check Noise at start up

Turn on Power and check operation noise.

- >> **If an abnormal noise does not show, replace Controller PCB.**

Check Point 4 : Check Voltage from Controller PCB

- ❑ Remove Connector and check Voltage (DC12V).

- >> **If it does not appear, replace Controller PCB.**



Check Point 5 : Check Opening and Closing Operation of Valve

When Valve is closed,
it has a temp. difference between Inlet and Outlet.

CLOSE
Example : Hot Gas

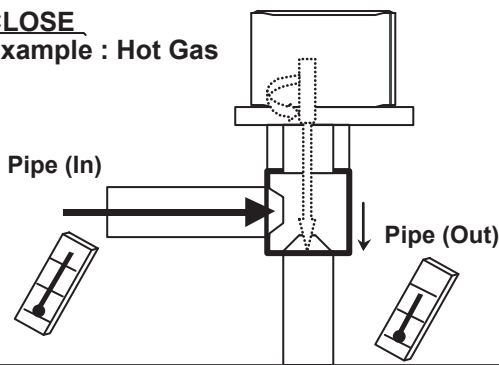

If it is open,
it has no temp. difference between Inlet and Outlet.

OPEN
Example : Hot Gas

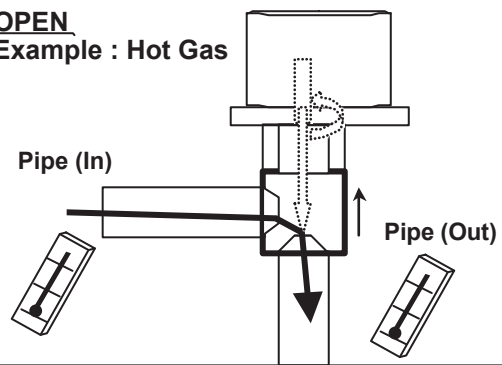

Check Point 6 : Check Strainer

Strainer normally does not have temperature difference between inlet and outlet as shown in (1), but if there is a difference as shown in (2), there is a possibility of inside clogged. In this case, replace Strainer.

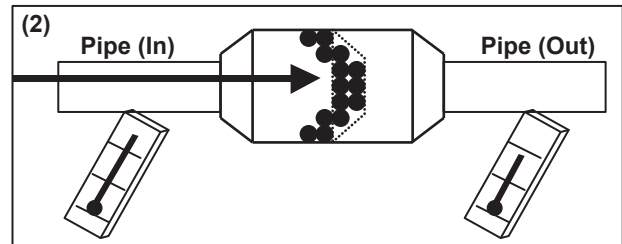
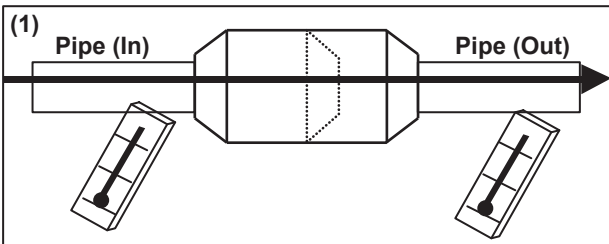

SERVICE PARTS INFORMATION 9

Outdoor Unit Electronic Expansion Valve (EEV)

Check Point 1 : Check Connections

- Check connection of connector (CN116)
(Loose connector or open cable)

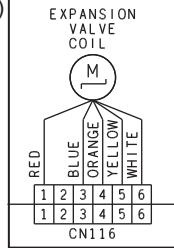

Check Point 2 : Check Coil of EEV1

- Remove connector, check each winding resistance of Coil.

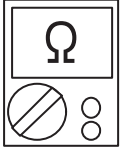
Read wire	Resistance value (20 °C)
White - Red	$46 \pm 3.7 \Omega$ 
Yellow - Red	
Orange - Red	
Blue - Red	

▶ If Resistance value is abnormal, replace EEV.

Check Point 3 : Check Noise at start up

- Turn on Power and check operation noise.
 >> **If an abnormal noise does not show, replace Controller PCB.**

Check Point 4 : Check Voltage from Controller PCB

- Remove Connector and check Voltage (DC12V).
 >> **If it does not appear, replace Controller PCB.**



Check Point 5 : Check Opening and Closing Operation of Valve

When Valve is closed, it has a temp. difference between Inlet and Outlet.

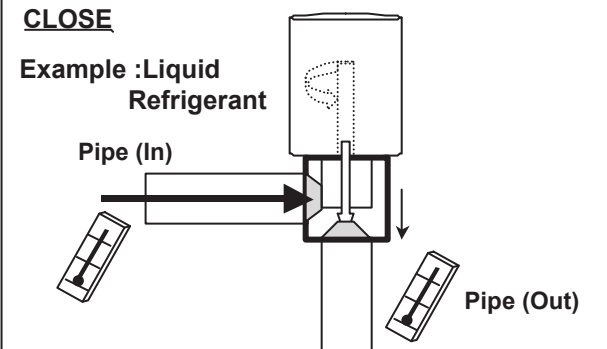

If it is open, it has no temp. difference between Inlet and Outlet.

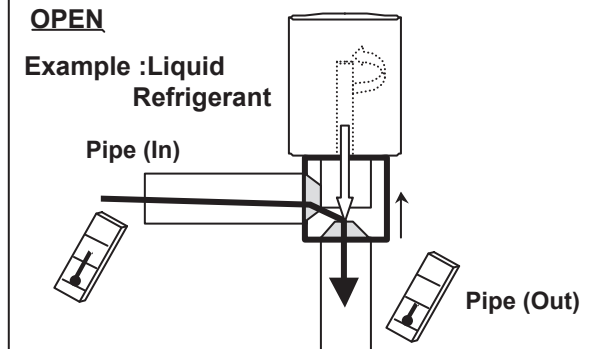

Check Point 6 : Check Strainer

Strainer normally does not have temperature difference between inlet and outlet as shown in (1), but if there is a difference as shown in (2), there is a possibility of inside clogged. In this case, replace Strainer.

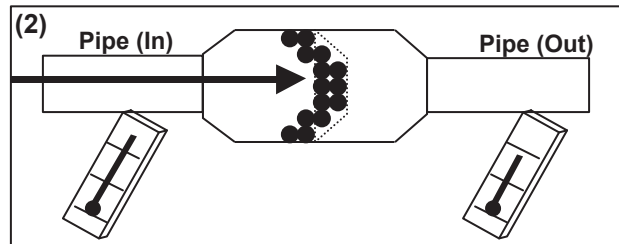
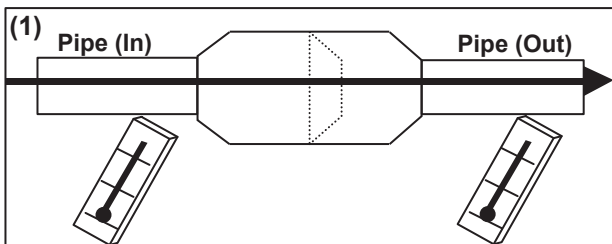

SERVICE PARTS INFORMATION 10

Outdoor Unit Solenoid Valve (SV)

Check Point 1 : Check connections

- ❑ Check connection of connector.
(Loose connector or open cable)

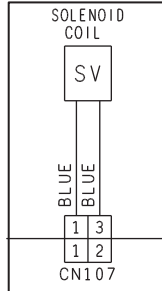

Check Point 2 : Check Solenoid Coil

- ❑ Remove connector and check if coil is open.
(Normal resistance value of each coil: $2085 \pm 10\% \Omega$)
>> **If Resistance value is abnormal, replace Solenoid Coil.**

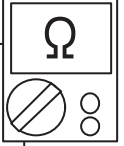

Check Point 3 : Check Voltage from Controller PCB

- ❑ Remove connector and check the voltage (Rated AC voltage).
>> **If the voltage does not appear, replace Controller PCB.**

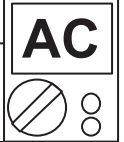

Check Point 4 : Check opening & closing operation of Valve

- ❑ Depending on either during operation or protection control, check if Valve is operating normally.
(When Valve opens, there is no temperature difference between Inlet and Outlet.)

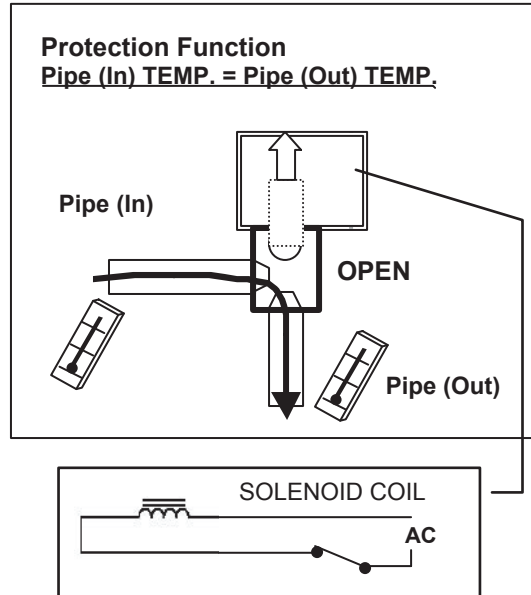
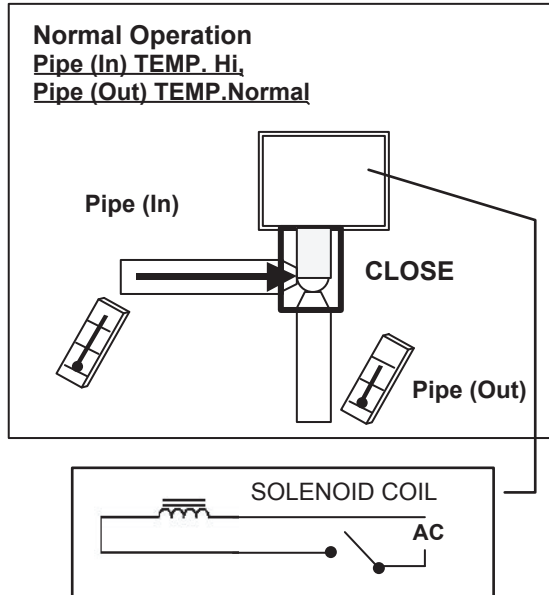

- ❑ If the valve closes by removing the connector of the valve which does not close, it is considered to be Controller PCB failure. Replace Controller PCB.

- ❑ If it does not close by removing connector, there is a possibility of (1) clogging by dirt, or (2) deformation by the heat at the time of Solenoid Valve installation. In this case, replace Solenoid Valve.

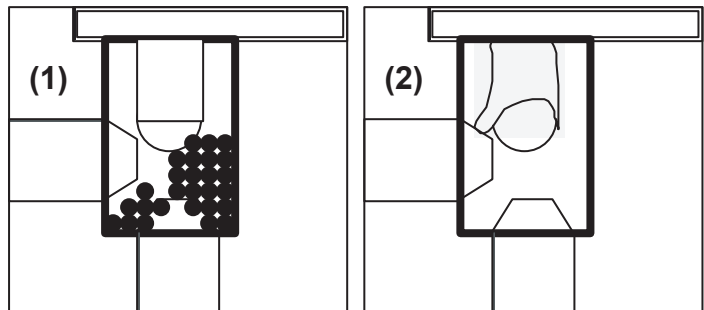

SERVICE PARTS INFORMATION 11

4-WAY VALVE

Check Point 1 : Check Circuit connection

- Check the connection of connector CN 105

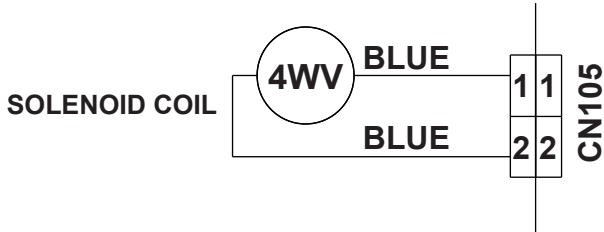

Check Point 2 : Check Solenoid Coil

- Remove CN6 from PCB and check the resistance value of coil

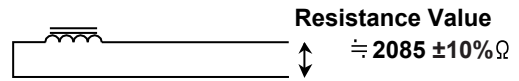

- ☆ If it is Open or abnormal resistance value, replace Solenoid Coil

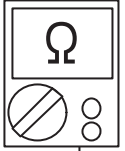

Check Point 3: Check Operation of 4-Way Valve

- Check each piping temperature, and confirm the location of the valve by the temperature difference.

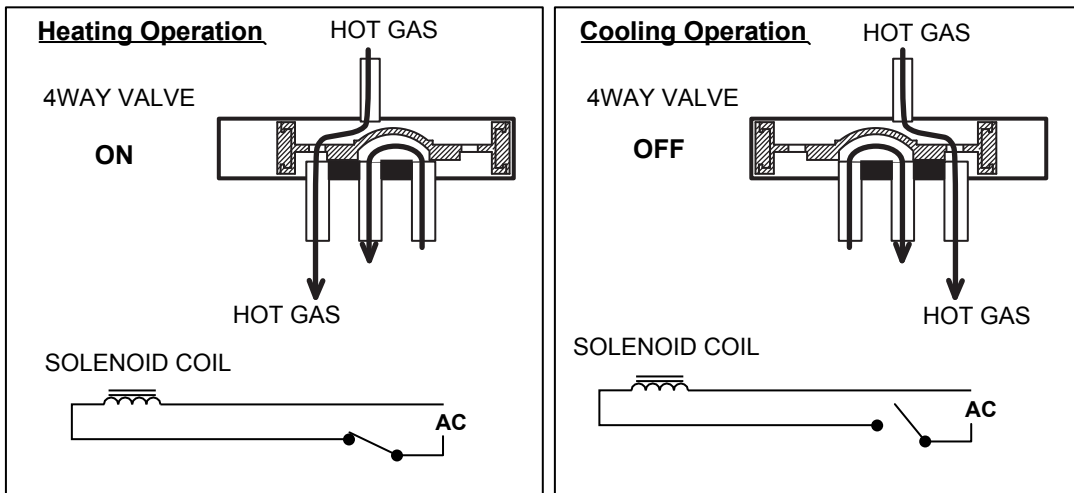

- ☆ If the valve location is not proper, replace 4 way valve.

Check Point 4: Check Voltage from Controller PCB

- Remove connector and check the voltage (Rated AC voltage).
>> **If the voltage does not appear, replace Controller PCB.**

SERVICE PARTS INFORMATION 12-1

Indoor Unit Fan Motor <AC motor>

Check Point : ARXB24GALH (Low Static pressure Duct Type)

□ Check each winding resistance of the motor

▶ If Resistance value is abnormal, replace motor.

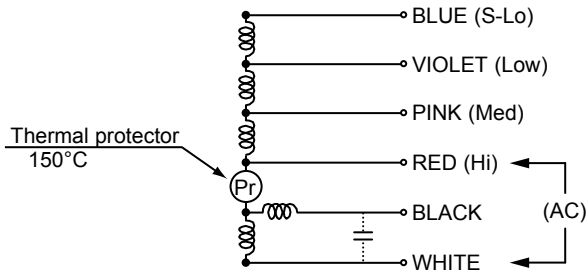

Lead wire	Resistance value
White – Red	44.8 Ω \pm 8%
Red – Black	37.3 Ω \pm 8%
Red – Pink	21.3 Ω \pm 8%
Pink – Violet	12.9 Ω \pm 8%
Violet – Blue	12.9 Ω \pm 8%

at 20°C

Check Point : ARXB30/ 36GALH (Low Static pressure Duct Type)

□ Check each winding resistance of the motor

▶ If Resistance value is abnormal, replace motor.

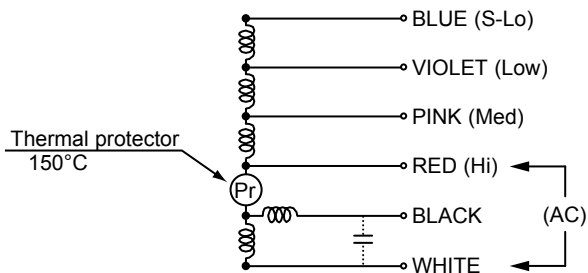

Lead wire	Resistance value
White – Red	47.1 Ω \pm 8%
Red – Black	27.4 Ω \pm 8%
Red – Pink	8.00 Ω \pm 8%
Pink – Violet	8.00 Ω \pm 8%
Violet – Blue	8.00 Ω \pm 8%

at 20°C

Check Point : ARXB45GALH (Low Static pressure Duct Type)

□ Check each winding resistance of the motor

▶ If Resistance value is abnormal, replace motor.

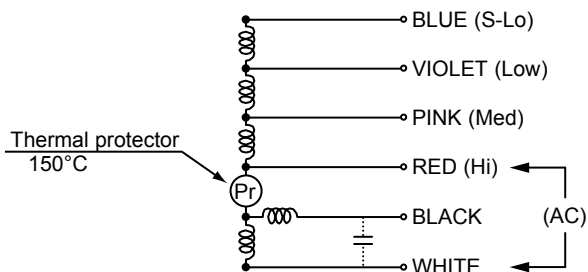

Lead wire	Resistance value
White – Red	19.7 Ω \pm 8%
Red – Black	13.8 Ω \pm 8%
Red – Pink	5.86 Ω \pm 8%
Pink – Violet	5.86 Ω \pm 8%
Violet – Blue	5.86 Ω \pm 8%

at 20°C

Check Point : ARXA24/ 30GALH (Duct Type)

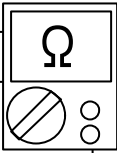

- Check each winding resistance of the motor
- ▶ **If Resistance value is abnormal, replace motor.**

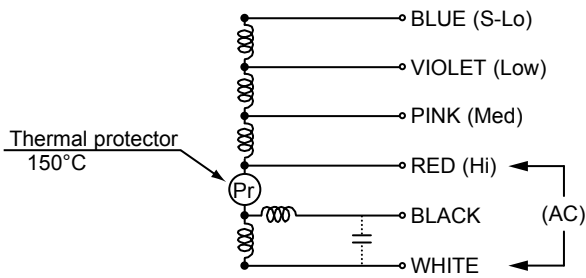

Lead wire	Resistance value
White – Red	47.1 Ω \pm 8%
Red – Black	27.4 Ω \pm 8%
Red – Pink	8.00 Ω \pm 8%
Pink – Violet	8.00 Ω \pm 8%
Violet – Blue	8.00 Ω \pm 8%

at 20°C

Check Point : ARXA36/ 45GALH (Duct Type)

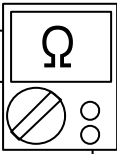

- Check each winding resistance of the motor
- ▶ **If Resistance value is abnormal, replace motor.**

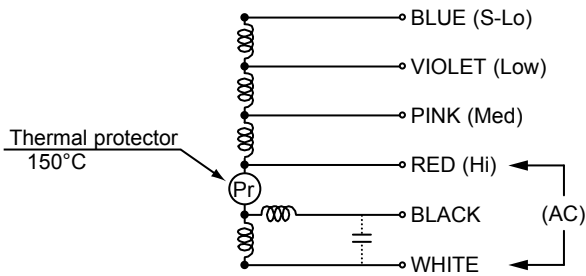

Lead wire	Resistance value
White – Red	19.7 Ω \pm 8%
Red – Black	13.0 Ω \pm 8%
Red – Pink	5.86 Ω \pm 8%
Pink – Violet	5.86 Ω \pm 8%
Violet – Blue	5.86 Ω \pm 8%

at 20°C

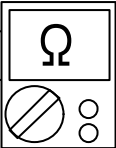

Check Point : ARXB07GALH (Compact Duct Type)

- ❑ Check each winding resistance of the motor
- ▶ **If Resistance value is abnormal, replace motor.**

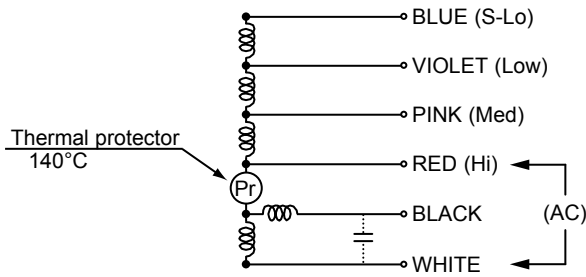

Lead wire	Resistance value
White – Red	579 Ω ± 8%
Red – Black	255 Ω ± 8%
Red – Pink	162 Ω ± 8%
Pink – Violet	66 Ω ± 8%
Violet – Blue	93 Ω ± 8%

at 20°C

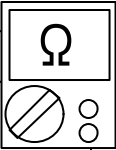

Check Point : ARXB09GALH (Compact Duct Type)

- ❑ Check each winding resistance of the motor
- ▶ **If Resistance value is abnormal, replace motor.**

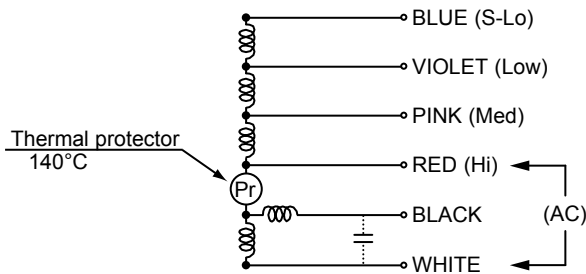

Lead wire	Resistance value
White – Red	322.8 Ω ± 8%
Red – Black	255 Ω ± 8%
Red – Pink	103 Ω ± 8%
Pink – Violet	53 Ω ± 8%
Violet – Blue	100.7 Ω ± 8%

at 20°C

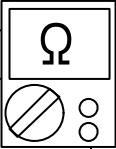

Check Point : ARXB12GALH (Compact Duct Type)

- ❑ Check each winding resistance of the motor
- ▶ **If Resistance value is abnormal, replace motor.**

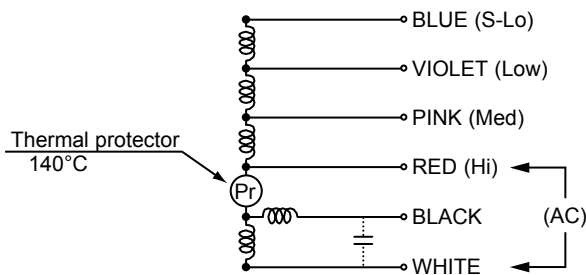

Lead wire	Resistance value
White – Red	336 Ω ± 8%
Red – Black	261 Ω ± 8%
Red – Pink	107 Ω ± 8%
Pink – Violet	55 Ω ± 8%
Violet – Blue	103 Ω ± 8%

at 20°C

Check Point : ARXC36GATH (High Static Pressure Duct Type)

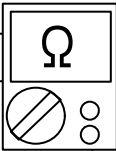

- Check each winding resistance of the motor
- If Resistance value is abnormal, replace motor.**

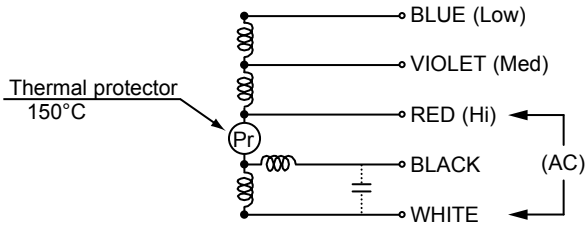

Lead wire	Resistance value
White – Red	13.4 Ω ± 8%
Red – Black	16.9 Ω ± 8%
Red – Violet	11.5 Ω ± 8%
Violet – Blue	13.3 Ω ± 8%

at 20°C

Check Point : ARXC45/ 60GATH (High Static Pressure Duct Type)

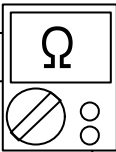

- Check each winding resistance of the motor
- If Resistance value is abnormal, replace motor.**

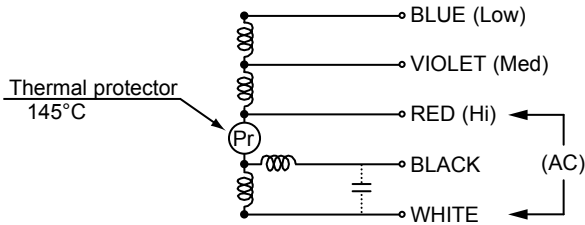

Lead wire	Resistance value
White – Red	6.84 Ω ± 7%
Red – Black	9.78 Ω ± 7%
Red – Violet	6.1 Ω ± 7%
Violet – Blue	6.1 Ω ± 7%

at 20°C

Check Point : ARXC72GATH (High Static Pressure Duct Type)

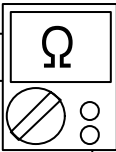

- Check each winding resistance of the motor
- If Resistance value is abnormal, replace motor.**

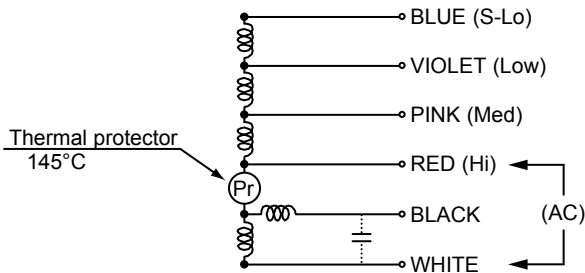

Lead wire	Resistance value
White – Red	5.25 Ω ± 7%
Red – Black	5.02 Ω ± 7%
Red – Pink	1.86 Ω ± 7%
Pink – Violet	0.94 Ω ± 7%
Violet – Blue	0.94 Ω ± 7%

at 20°C

Check Point : ARXC90GATH (High Static Pressure Duct Type)

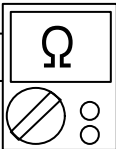

- Check each winding resistance of the motor
- If Resistance value is abnormal, replace motor.**

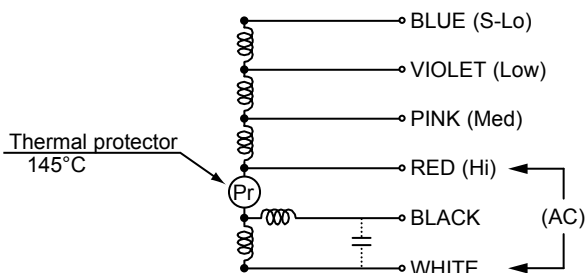

Lead wire	Resistance value
White – Red	4.24 Ω ± 7%
Red – Black	4.16 Ω ± 7%
Red – Pink	0.46 Ω ± 7%
Pink – Violet	0.91 Ω ± 7%
Violet – Blue	0.46 Ω ± 7%

at 20°C

Check Point : ARXB14GALH (Compact Duct Type)

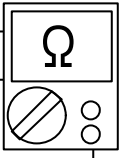

- Check each winding resistance of the motor
- ▶ **If Resistance value is abnormal, replace motor.**

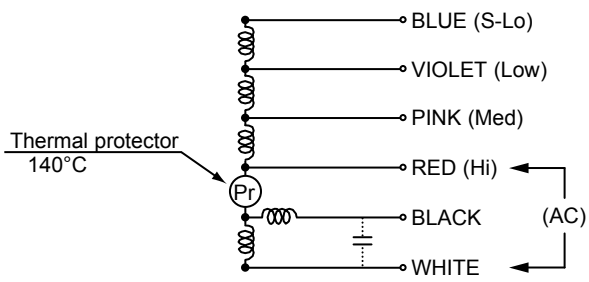

Lead wire	Resistance value
White – Red	136.5 Ω \pm 8%
Red – Black	125.6 Ω \pm 8%
Red – Pink	23.7 Ω \pm 8%
Pink – Violet	23.7 Ω \pm 8%
Violet – Blue	49.4 Ω \pm 8%

at 20°C

Check Point : ARXB18GALH (Compact Duct Type)

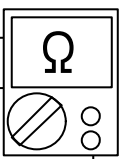

- Check each winding resistance of the motor
- ▶ **If Resistance value is abnormal, replace motor.**

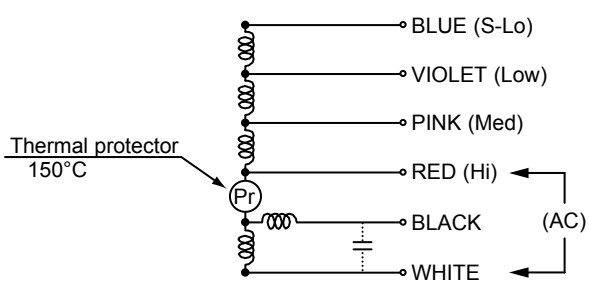

Lead wire	Resistance value
White – Red	89.7 Ω \pm 8%
Red – Black	150 Ω \pm 8%
Red – Pink	37.4 Ω \pm 8%
Pink – Violet	37.4 Ω \pm 8%
Violet – Blue	197 Ω \pm 8%

at 20°C

SERVICE PARTS INFORMATION 12-2

Indoor Unit Fan Motor <DC motor>

- AUXB 04, 07,09,12,14,18,24 - AUXD 18,24 - AUXA 30,36,45, 54 - ARXA24,30,36,45GBLH
- ARXD 07,09,12,14,18,24 - ARXN009,012,014GLBH - AB*A 12,14,18,24,30,36,45,54
- AS*A 04, 07,09,12,14,18,24,30 - AS*E 04, 07,09,12,14

⚠ When you approach this part, please cut off the power supply and wait for a while until DC voltage has been discharged.

Check Point 1 : Check rotation of Fan

- Rotate the fan by hand when operation is off.
(Check if fan is caught, dropped off or locked motor)
- >>If Fan or Bearing is abnormal, replace it.**

Check Point 2 : Check resistance of Indoor Fan Motor

- Refer to below. Circuit-test "Vm" and "GND" terminal.
(Vm: DC voltage, GND: Earth terminal)
- >>If they are short-circuited (below 300 kΩ), replace Indoor fan motor and Controller PCB.**

Pin number (wire color)	Terminal function (symbol)
1 (Brown or Blue)	Feed back (FG)
2 (Yellow)	Speed command (Vsp)
3 (White)	Control voltage (Vcc)
4 (Black)	Earth terminal (GND)
5	No function
6 (Red)	DC voltage (Vm)

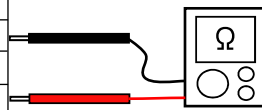

SERVICE PARTS INFORMATION 12-3

Indoor Unit Fan Motor <DC motor>
(Lower fan motor of Compact Floor model)

⚠ When you approach this part, please cut off the power supply and wait for a while until DC voltage has been discharged.

Check Point 1 : Check rotation of Fan

- Rotate the fan by hand when operation is off.
(Check if fan is caught, dropped off or locked motor)
- >>If Fan or Bearing is abnormal, replace it.**

Check Point 2 : Check resistance of Indoor Fan Motor

- Refer to below. Circuit-test "Vm" and "GND" terminal.
(Vm: DC voltage, GND: Earth terminal)
- >>If they are short-circuited (below 300 kΩ), replace Indoor fan motor and Controller PCB.**

Pin number (wire color)	Terminal function (symbol)
1 (Blue)	Feed back (FG)
2 (Yellow)	Speed command (Vsp)
3 (White)	Control voltage (Vcc)
4 (Black)	Earth terminal (GND)
5	No function
6	No function
7 (Red)	DC voltage (Vm)



SERVICE PARTS INFORMATION 12-4

Indoor Unit Fan Motor <DC motor>
(For AS*A030/ 034GTAH, AUXK018 - 054GLAH)

⚠ When you approach this part, please cut off the power supply and wait for a while until DC voltage has been discharged.

Check Point 1 : Check rotation of Fan

- Rotate the fan by hand when operation is off.
(Check if fan is caught, dropped off or locked motor)
- >>If Fan or Bearing is abnormal, replace it.**

Check Point 2 : Check resistance of Indoor Fan Motor

- Refer to below. Circuit-test "Vm" and "GND" terminal.
(Vm: DC voltage, GND: Earth terminal)
- >>If they are short-circuited (below 300 kΩ), replace Indoor fan motor and Controller PCB.**

Pin number (wire color)	Terminal function (symbol)
1 (Red)	DC voltage (Vm)
2	No function
3	No function
4 (Black)	Earth terminal (GND)
5 (White)	Control voltage (Vcc)
6 (Yellow)	Speed command (Vsp)
7 (Brown or Blue)	Feed back (FG)



SERVICE PARTS INFORMATION 13

Discharge Pressure Sensor Suction Pressure Sensor

1. Discharge Pressure Sensor

Check Point : Check Voltage from Main PCB

- With the connector connected to the PCB, measure the voltage between CN118:2-3 of the Main PCB.

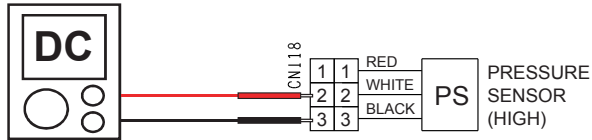

- Characteristics of pressure sensor

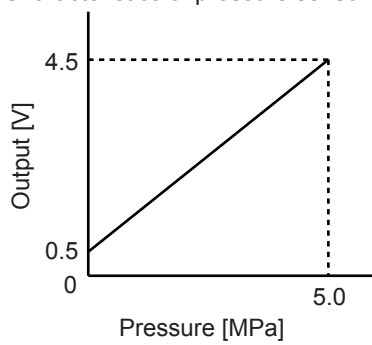

2. Suction Pressure Sensor

Check Point : Check Voltage from Main PCB

- With the connector connected to the PCB, measure the voltage between CN119:2-3 of the Main PCB.

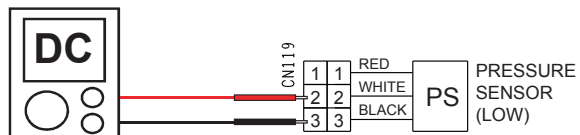

- Characteristics of pressure sensor

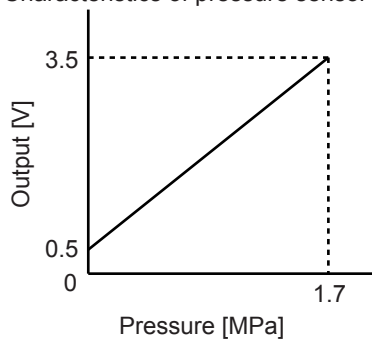

SERVICE PARTS INFORMATION 14

Thermistor

Check Point : Check Thermistor resistance value

▣ Remove connector and check Thermistor resistance value.

Temperature [°C]	Resistance Value [kΩ]		
	Thermistor A	Thermistor B	Thermistor C
- 20	---	---	105.4
- 10	---	27.8	58.2
- 5	---	21.0	44.0
0	168.6	16.1	33.6
5	129.8	12.4	25.9
10	100.9	9.6	20.2
15	79.1	7.6	15.8
20	62.6	6.0	12.5
25	49.8	4.8	10.0
30	40.0	3.8	8.0
40	26.3	2.5	5.3
50	17.8	1.7	3.6
60	12.3	1.2	---
70	8.7	---	---
80	6.3	---	---
90	4.6	---	---
100	3.4	---	---
110	2.6	---	---
120	2.0	---	---
Applicable Thermistors	Discharge temp. TH : [TH1] Comp temp. TH : [TH10]	Heat exchanger. TH : [TH5] Suction temp. TH : [TH4]	Outdoor temp. TH : [TH3]

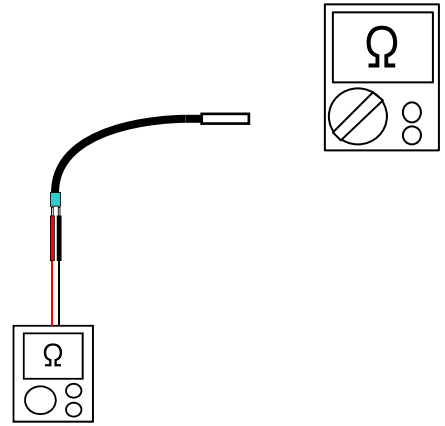

SERVICE PARTS INFORMATION 15

ACTPM (Active Filter Module)

Check Point 1 : Appearance check

- No fissures, breaks, damage, etc. at the body and terminals section?

Check Point 2 : Electric check

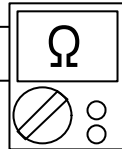

- ① Disconnect the connection wires.
- ② Set the tester to the "Resistance" mode, and measure the resistance between the following terminals.
 - L2 - P
 - L2 - N
- ③ Judge the result of ② as follows:

All 3 points several 100kΩ or greater	: Normal
1 or more points 100kΩ to short	: Defective

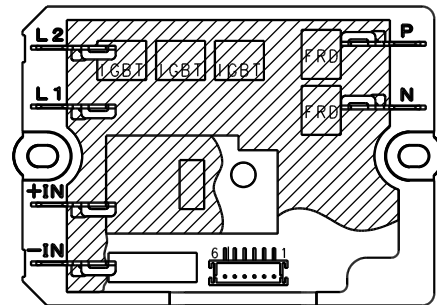

ACTPM for AJ*040/ 045

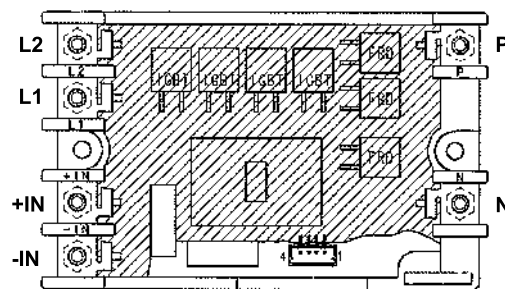

ACTPM for AJ*054

Check Point 3

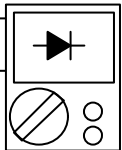

- ④ Set the tester to the "Diode" mode, and measure the voltage value between the following terminals.

Tester +side (red)	Tester - side (black)	Tester display [V]
L2	P	

- ⑤ Judge the result of ④ as follows:

Several 0.3V to 0.7V	: Normal
Under 0.1V or over load	: Defective

SERVICE PARTS INFORMATION 16

Outdoor Unit Fan Motor

⚠ When you approach this part, please cut off the power supply and wait for a while until DC voltage has been discharged.

Check Point 1 : Check rotation of Fan

- Rotate the fan by hand when operation is off.
(Check if fan is caught, dropped off or locked motor)
- >>If Fan or Bearing is abnormal, replace it.**

Check Point 2 : Check resistance of Outdoor Fan Motor

- Refer to below. Circuit-test "Vm" and "GND" terminal.
(Vm: DC voltage, GND: Earth terminal)
- >>If they are short-circuited (below 300 k Ω),
replace Outdoor fan motor.**

Pin number (wire color)	Terminal function (symbol)
1 (Red)	DC voltage (Vm)
2	No function
3	No function
4 (Black)	Earth terminal (GND)
5 (White)	Control voltage (Vcc)
6 (Yellow)	Speed command (Vsp)
7 (Brown)	Feed back (FG)

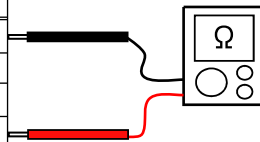

AIRSTAGE™ J-IIS

Variable Refrigerant Flow System

5. APPENDING DATA (UNIT)

5-1 REFRIGERANT CIRCUIT

MODELS : AJ*040LCLAH, AJ*045LCLAH, AJ*054LCLAH

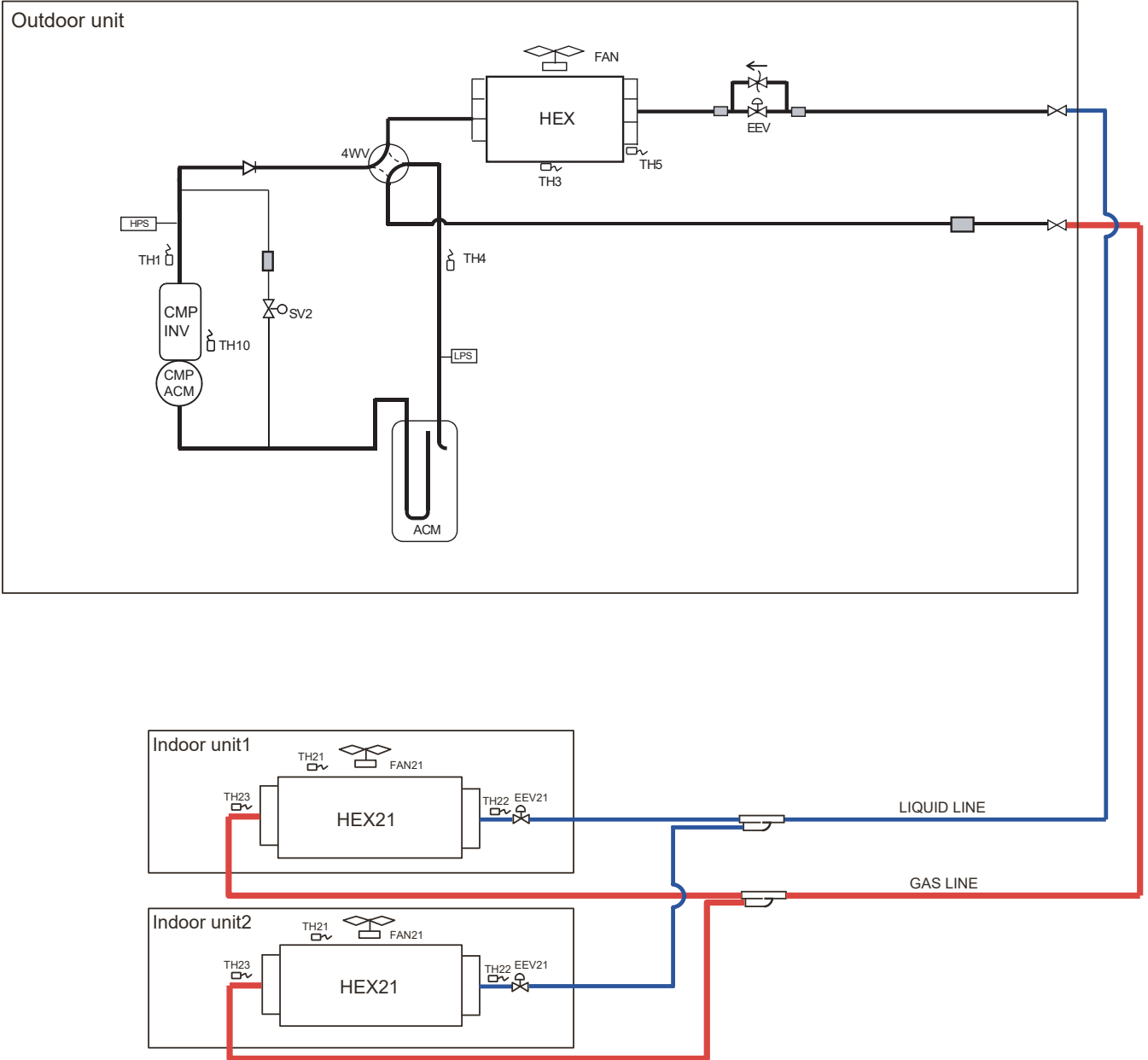

Outdoor unit		Indoor unit
LPS: Low Pressure Sensor	TH1: Discharge temp.	HEX21: Indoor uit Heatr Exchanger
HPS: High Pressure Sensor	TH3: Outdoor temp.	TH21: Room temp.
ACM: Accumulator	TH4: Suction temp.	TH22: Heat Exchanger (Inlet) temp.
INV: Inverter Compressor	TH5: Heat Exchanger Liquid Pipe temp.	TH23: Heat Exchanger (Outlet) temp.
HEX: Heat Exchanger	TH10: Compressor (shell) temp	EEV21: Electric Expansion Valve (Refrigerant amount adjustment)
: Expansion Valve	SV2: Pressure Equalization Valve	FAN 21: Indoor unit FAN
: Solenoid Valve	EEV: Electric Expansion Valve (Total refrigerant amount control)	
: Strainer	FAN	
: Check Valve		
: Thermistor		
: Pressure Regulation Valve (Operation Pressure: 3.95MPa)		

5-1-1 REFRIGERANT CIRCUIT for Outdoor air unit

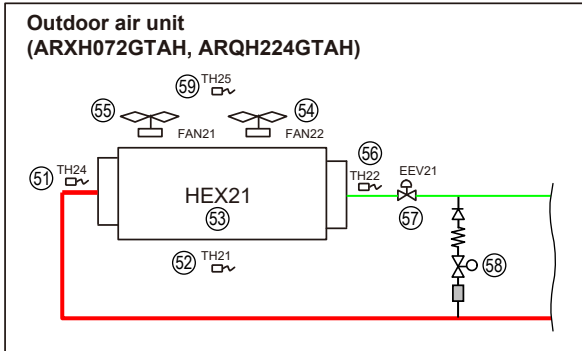
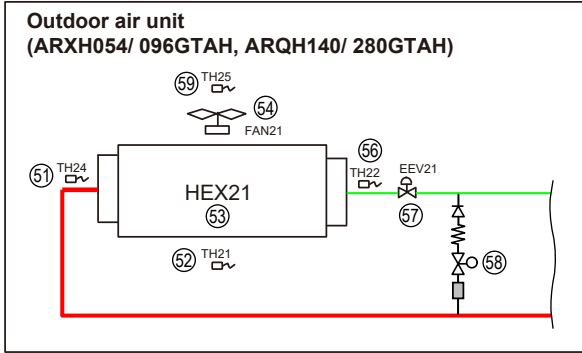

-W- : Capillary □ : Strainer

No.	Part name	Function
51	Heat exchanger outlet thermistor	Detects the temperature of refrigerant
52	Suction airflow temp. thermistor	Detects the temperature of suction airflow
53	Heat exchanger	Operates as Condensor / Evaporator
54	Fan motor	Controlled by setting / protection / Thermo OFF
55	Fan motor	Controlled by setting / protection / Thermo OFF
56	Heat exchanger inlet thermistor	Detects the temperature of refrigerant
57	Electric expansion valve	Controlled by setting / protection / Thermo OFF
58	Solenoid valve (Bypass)	Opens at Thermo OFF in Heating mode
59	Discharge airflow temp. thermistor	Detects the temperature of discharge airflow

5-2 WIRING DIAGRAM

5-2-1 Indoor Unit

MODELS : AUXB04GALH, AUXB07GA* H, AUXB09GA* H, AUXB12GA* H, AUXB14GA* H, AUXB18GA* H, AUXB24GA* H

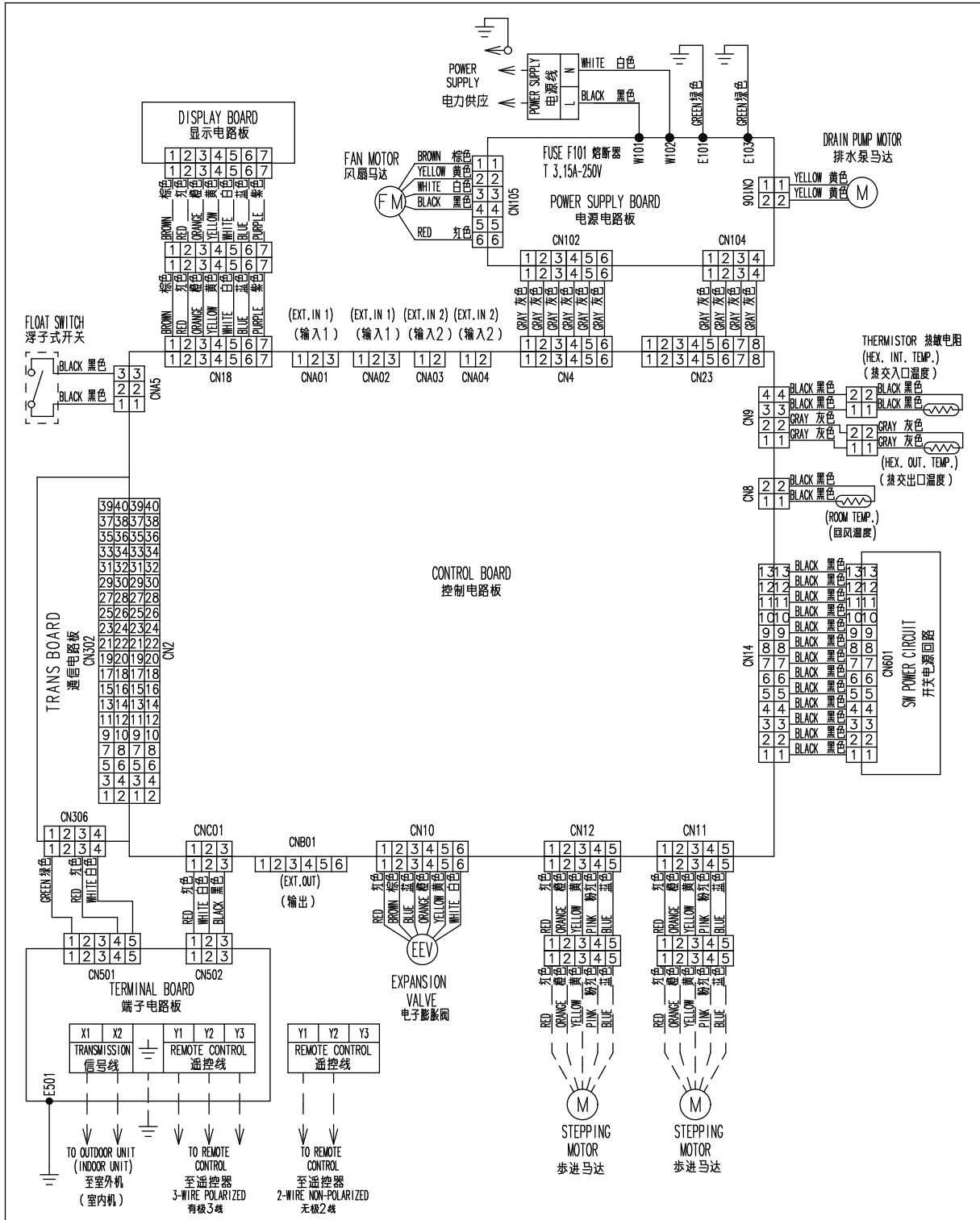

MODELS : AUXD18GA* H, AUXD24GA* H, AUXA30GA* H, AUXA34GA* H AUXA36GA* H, AUXA45GA* H, AUXA54GA* H

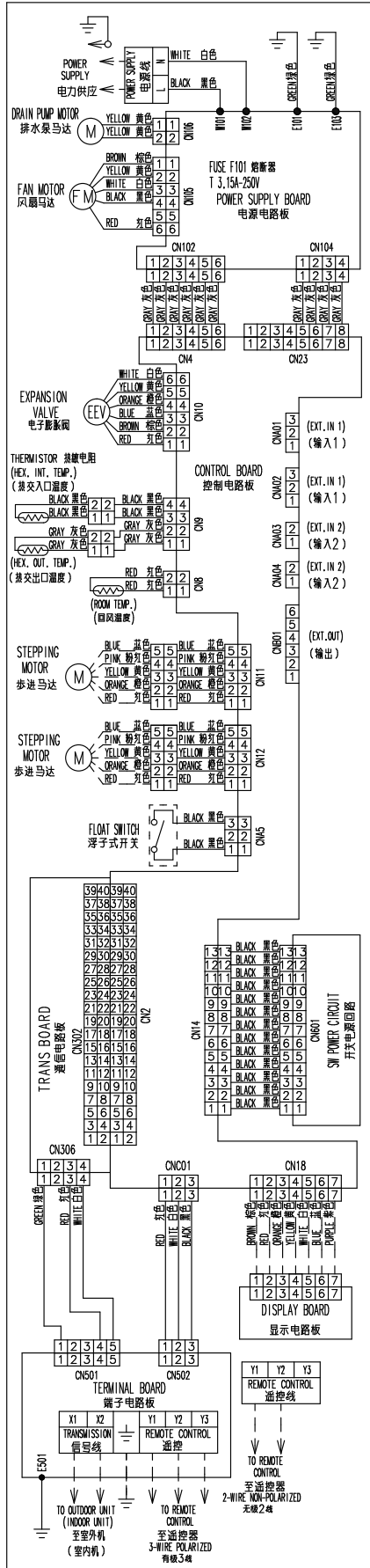

CASSETTE TYPE

MODELS : AUXK018/ 024/ 030/ 034/ 036/ 045/ 054GLAH

AUXM018/ 024/ 030GLAH, AUXN009/012/014GLAH

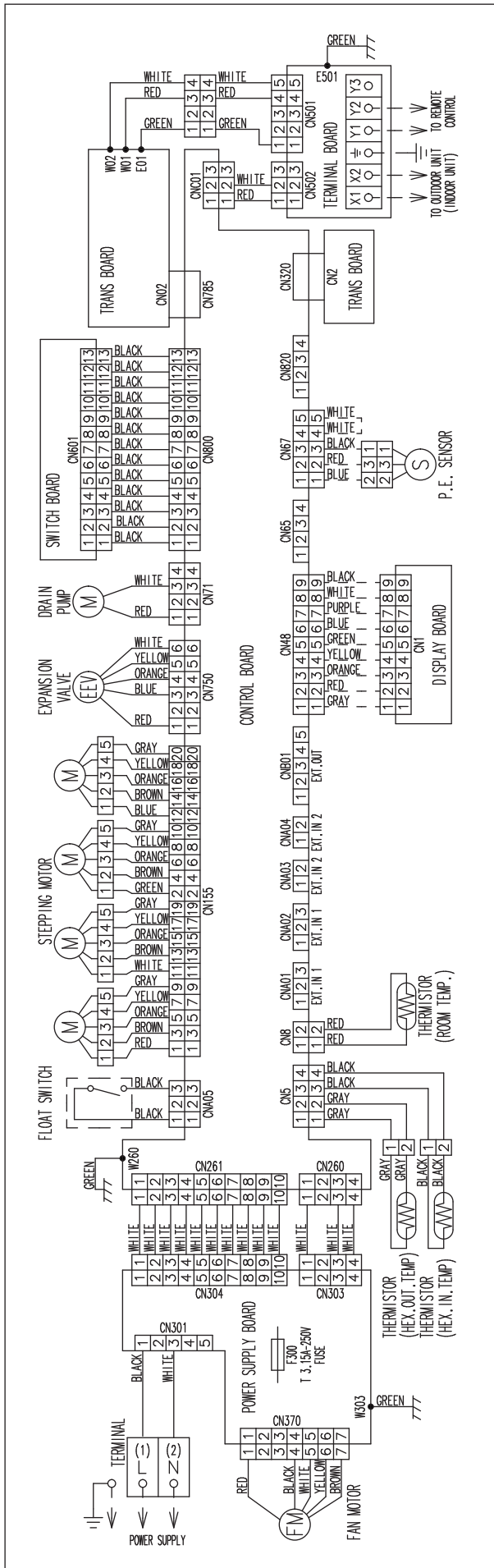

3D FLOW CASSETTE

MODELS : AUXS018GLEH
AUXS024GLEH

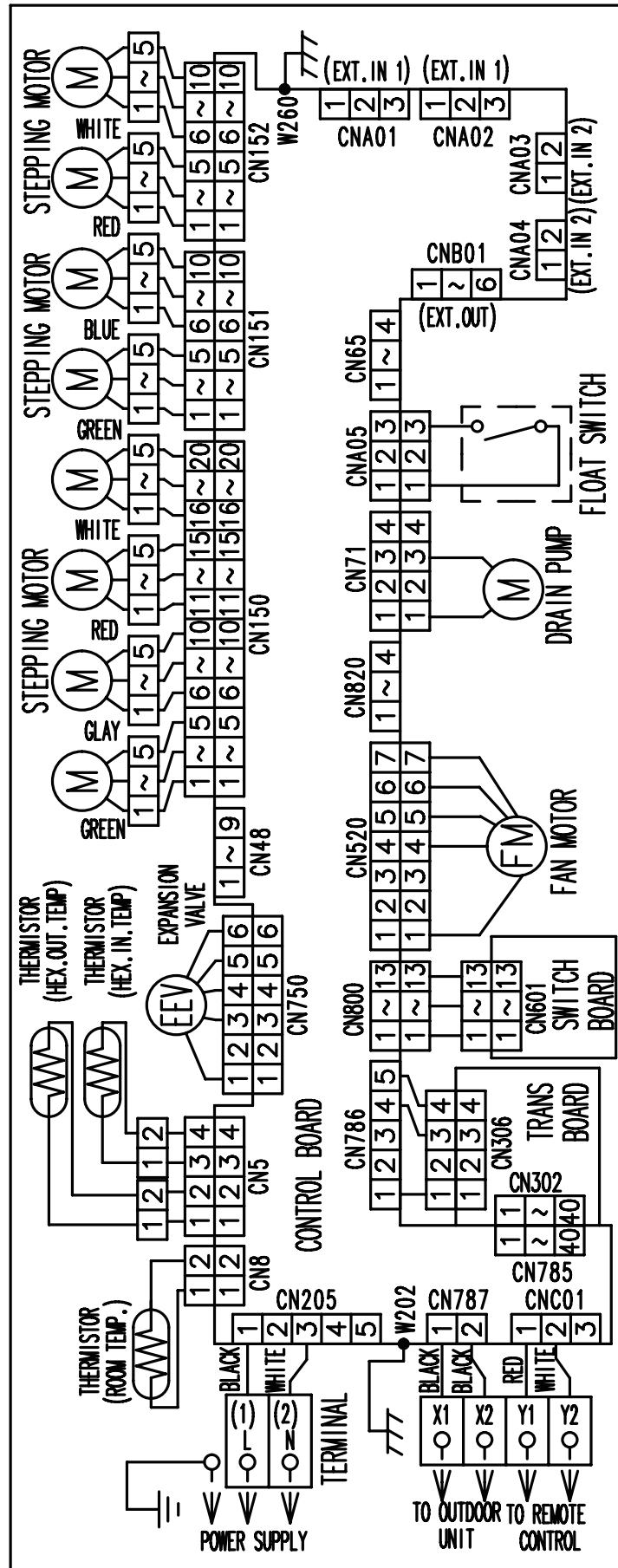

COMPACT CASSETTE TYPE

MODELS : AUXB04GBLH,
 AUXB04/ 07/ 09/ 12/ 14/ 18/ 24GALH
 AUXB07/ 09/ 12/ 14/ 18/ 24GATH

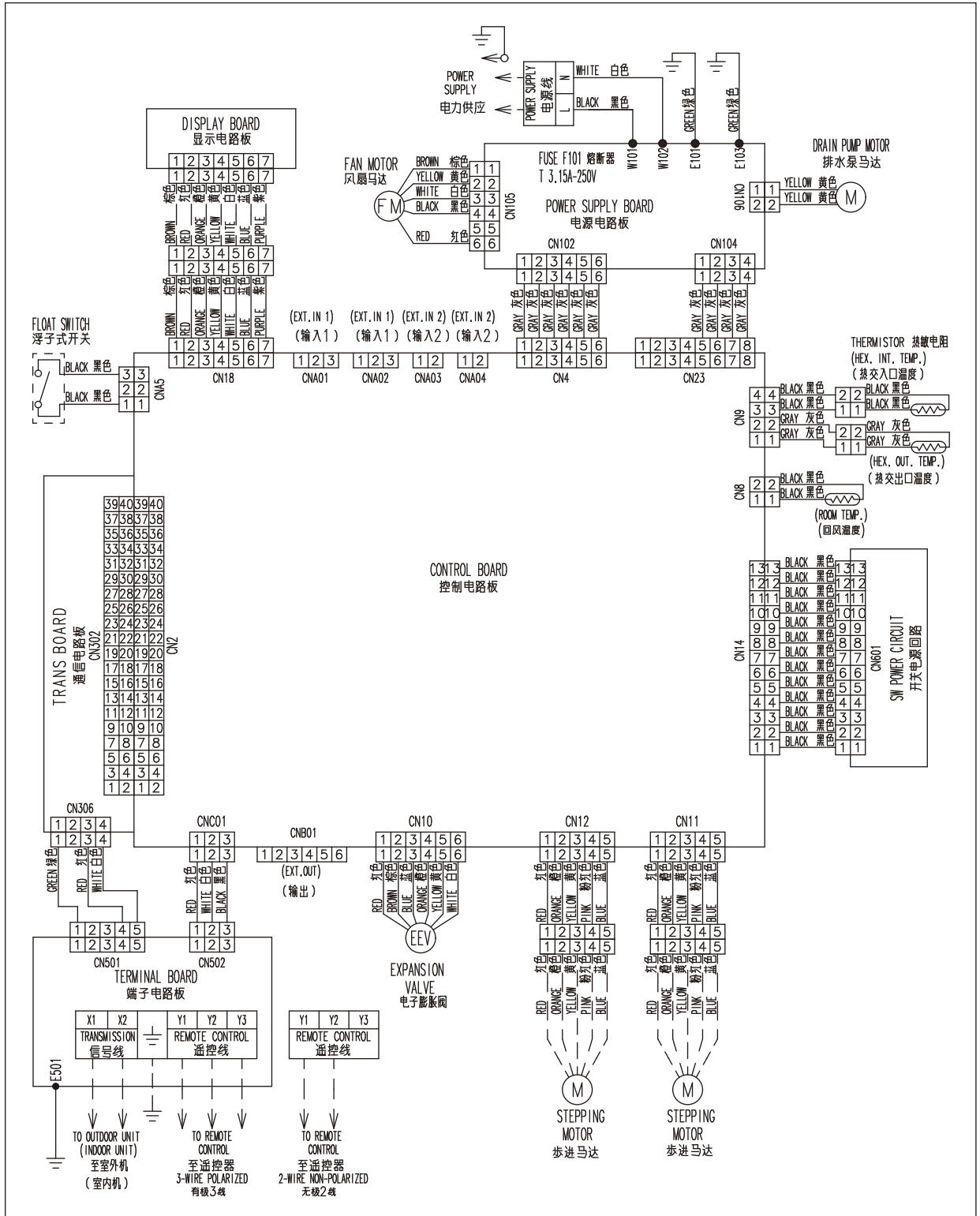

MODELS : ARXB07GALH, ARXB09GALH, ARXB12GALH, ARXB14GALH, ARXB18GALH

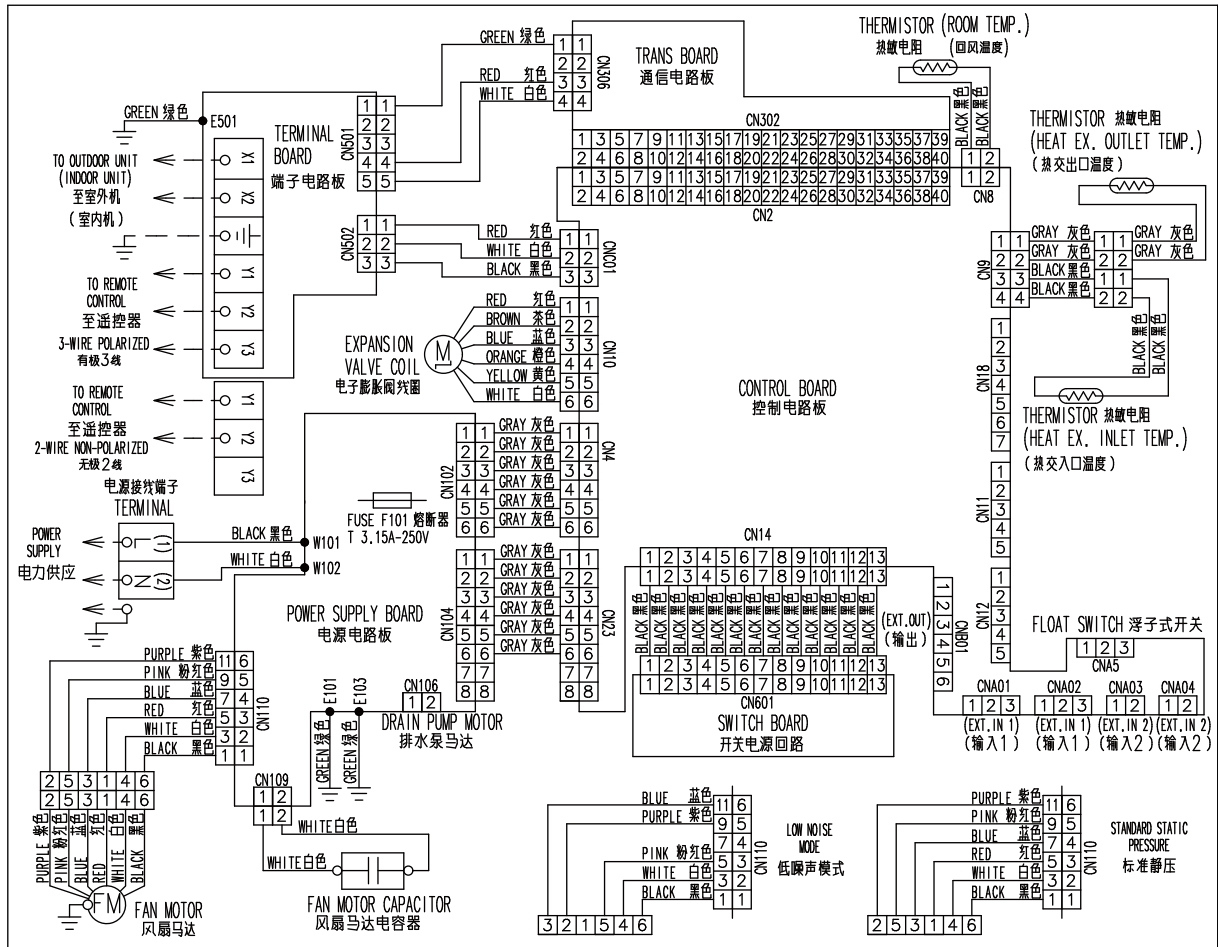

MODELS : ARXD07GA* H, ARXD09GA* H, ARXD12GA* H, ARXD14GA* H, ARXD18GA* H, ARXD24GA* H ARXN009GLBH, ARXN012GLBH, ARXN014GLBH

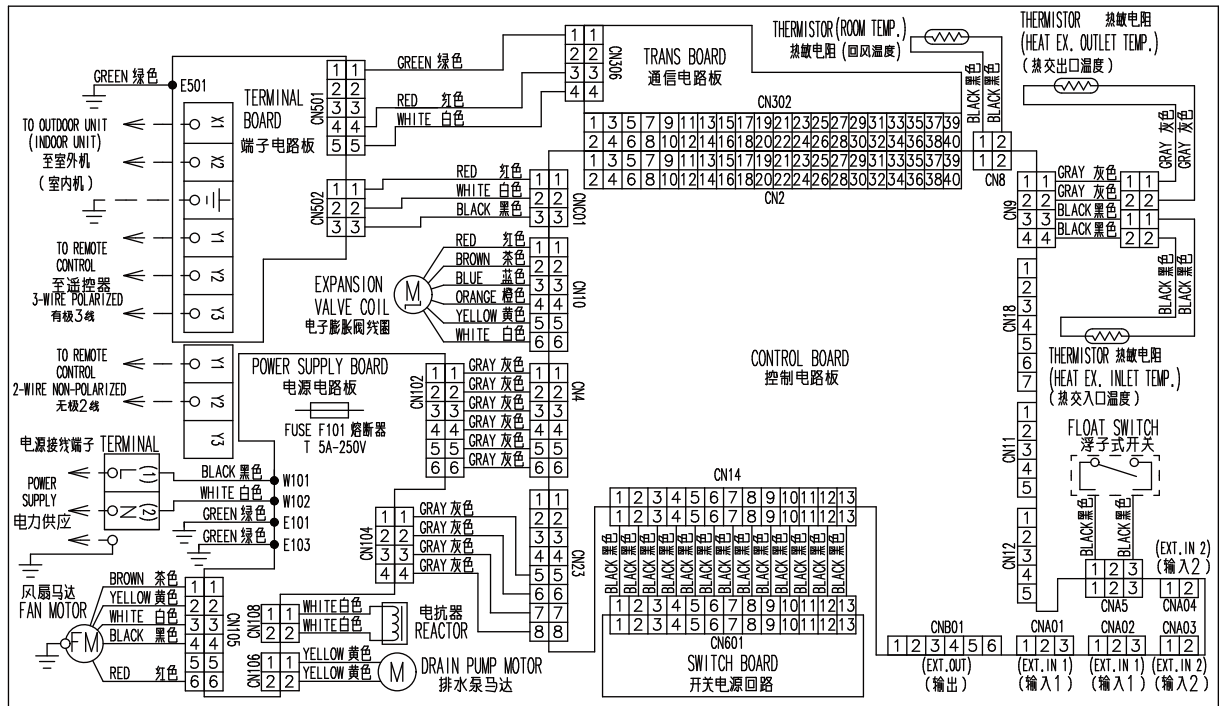

MODELS : ARXB24GALH, ARXB30GALH, ARXB36GALH

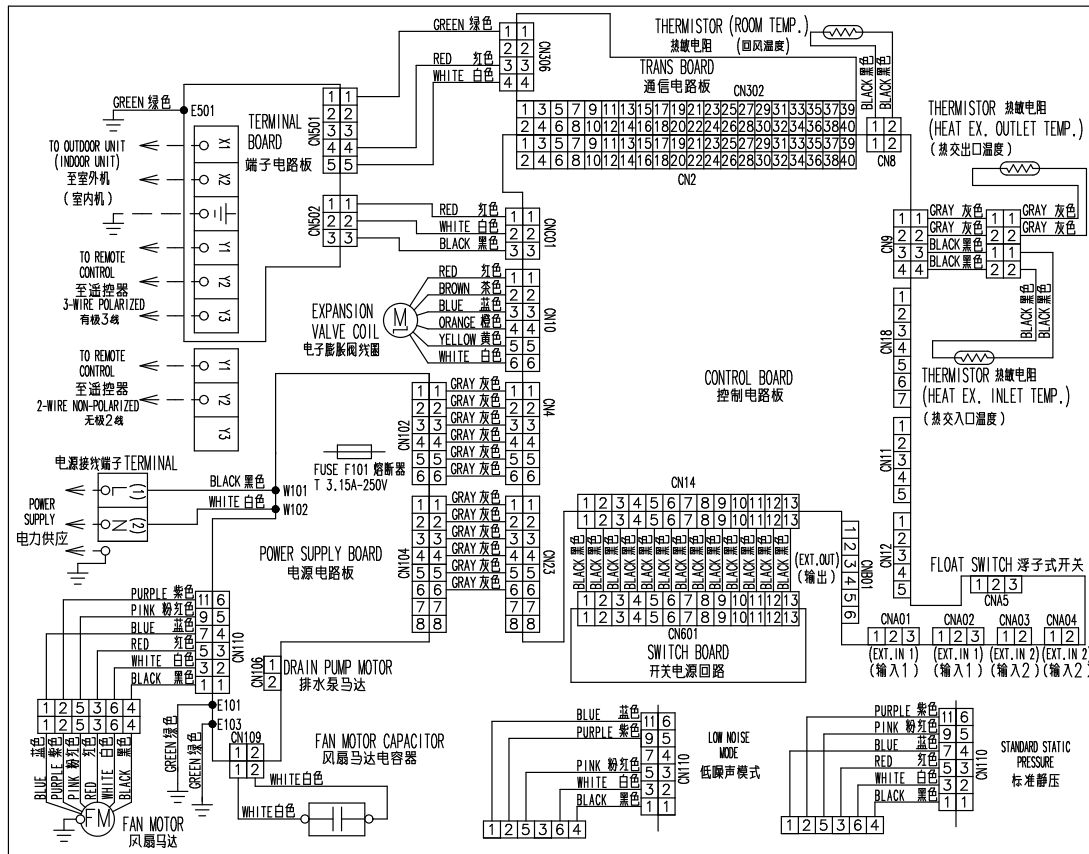

MODEL : ARXB45GALH

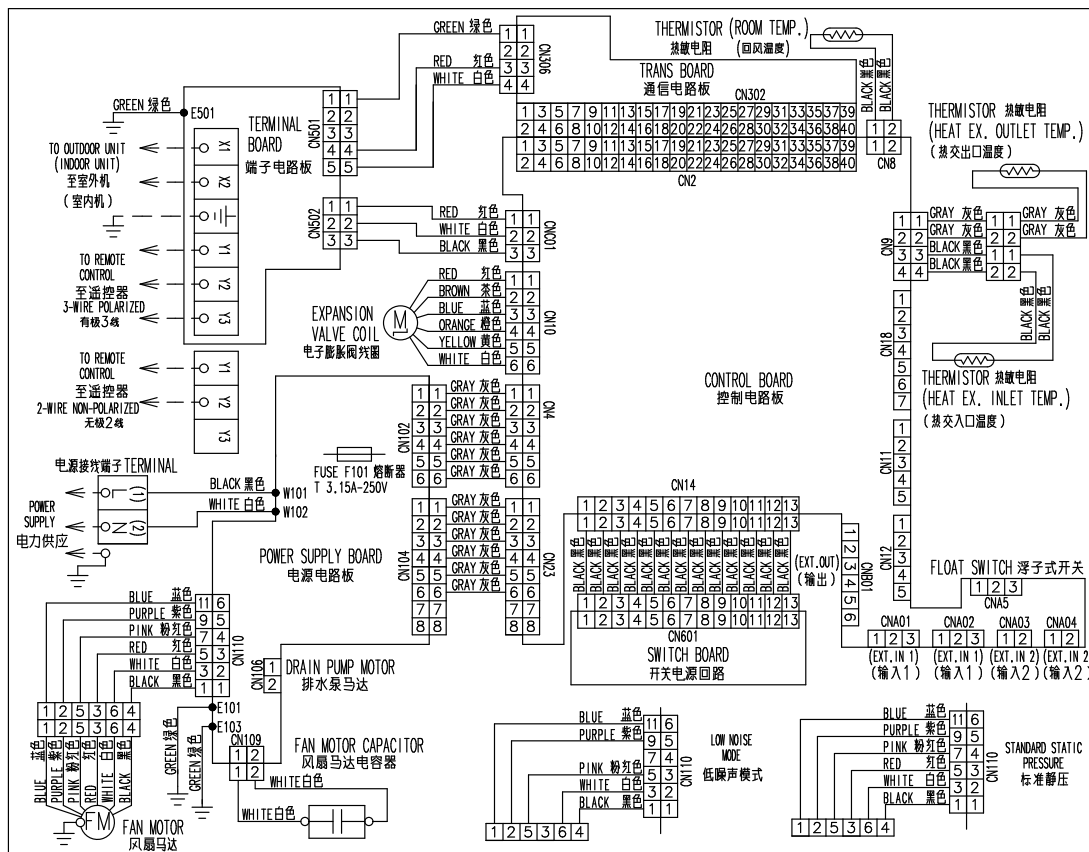

MODELS : ARXA24GALH, ARXA30GALH, ARXA36GALH, ARXA45GALH

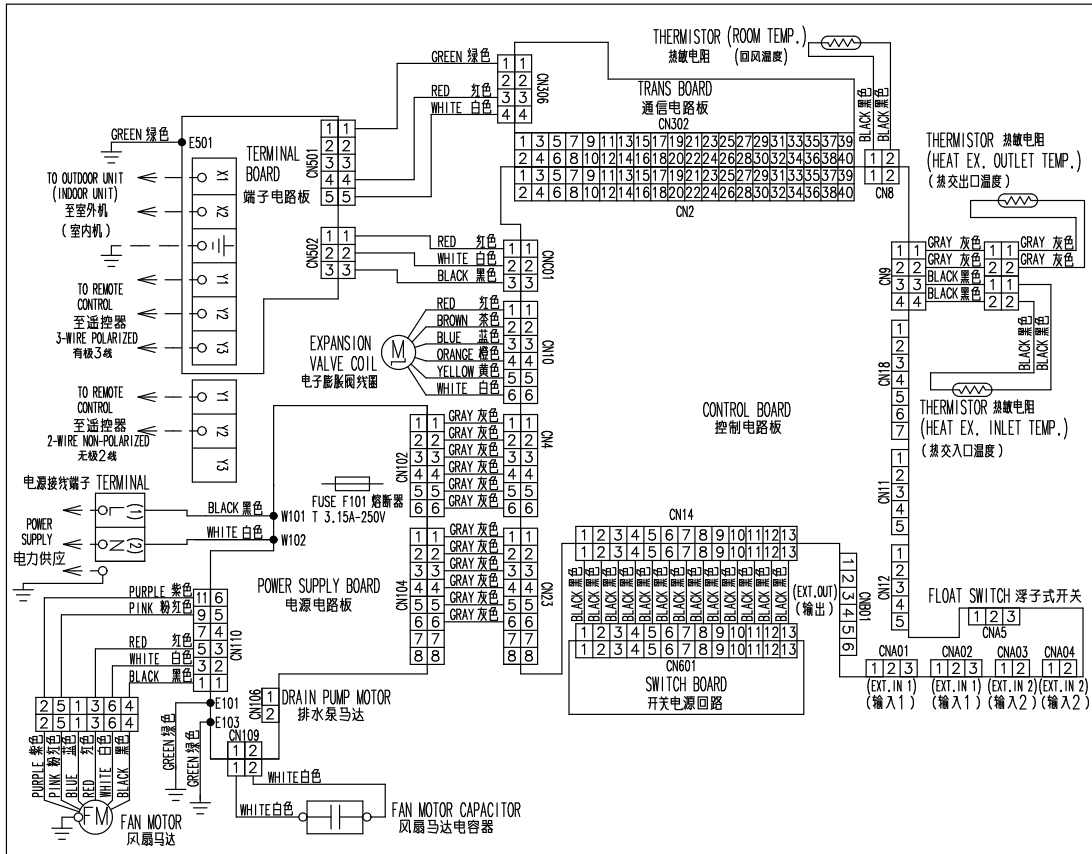

MODELS : ARXA24GB* H, ARXA30GB* H, ARXA36GB* H, ARXA45GB* H

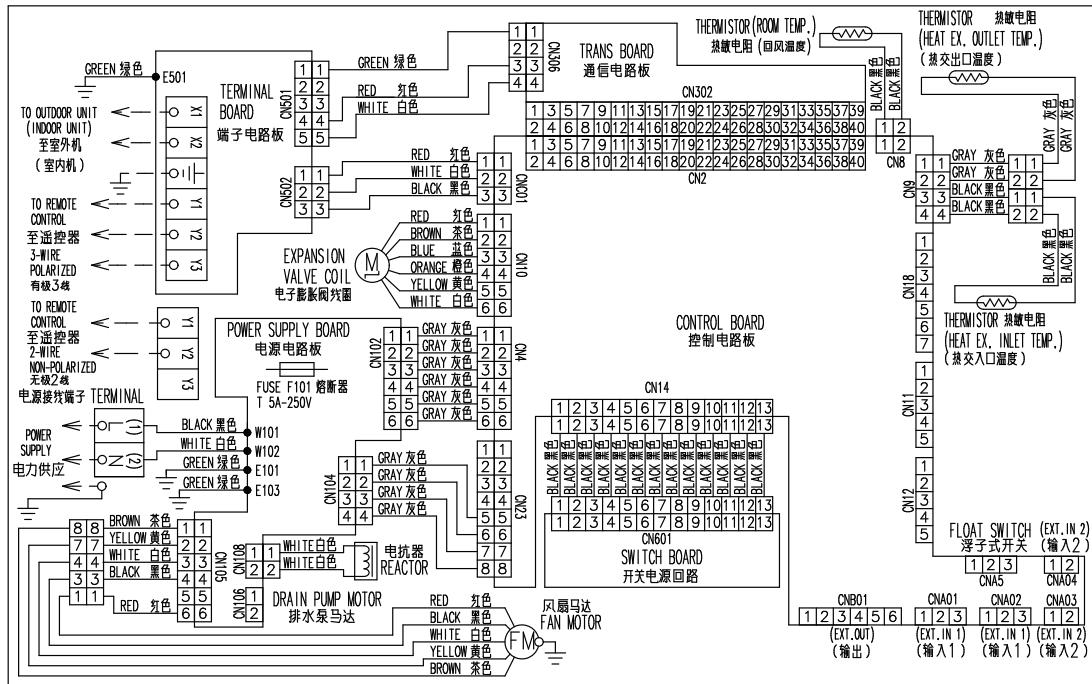

MODELS : ARXC36GATH, ARXC45GATH, ARXC60GATH

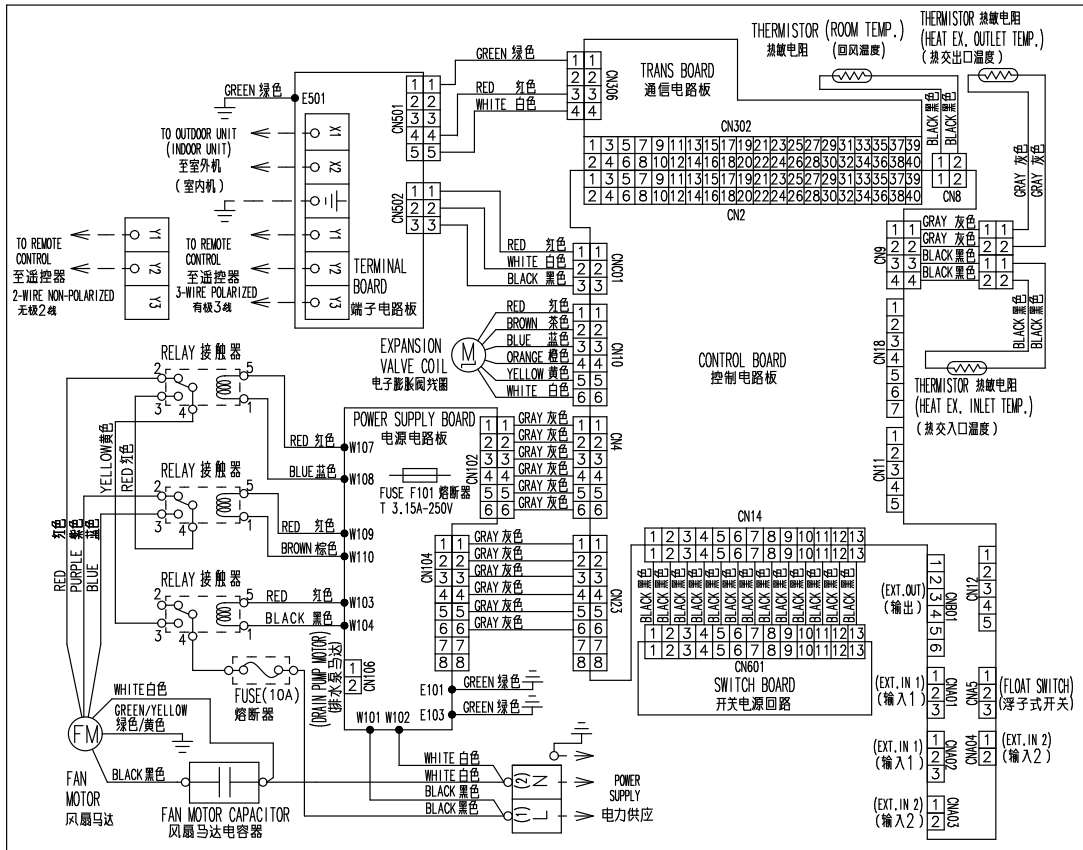

MODELS : ARXC72GATH, ARXC90GATH

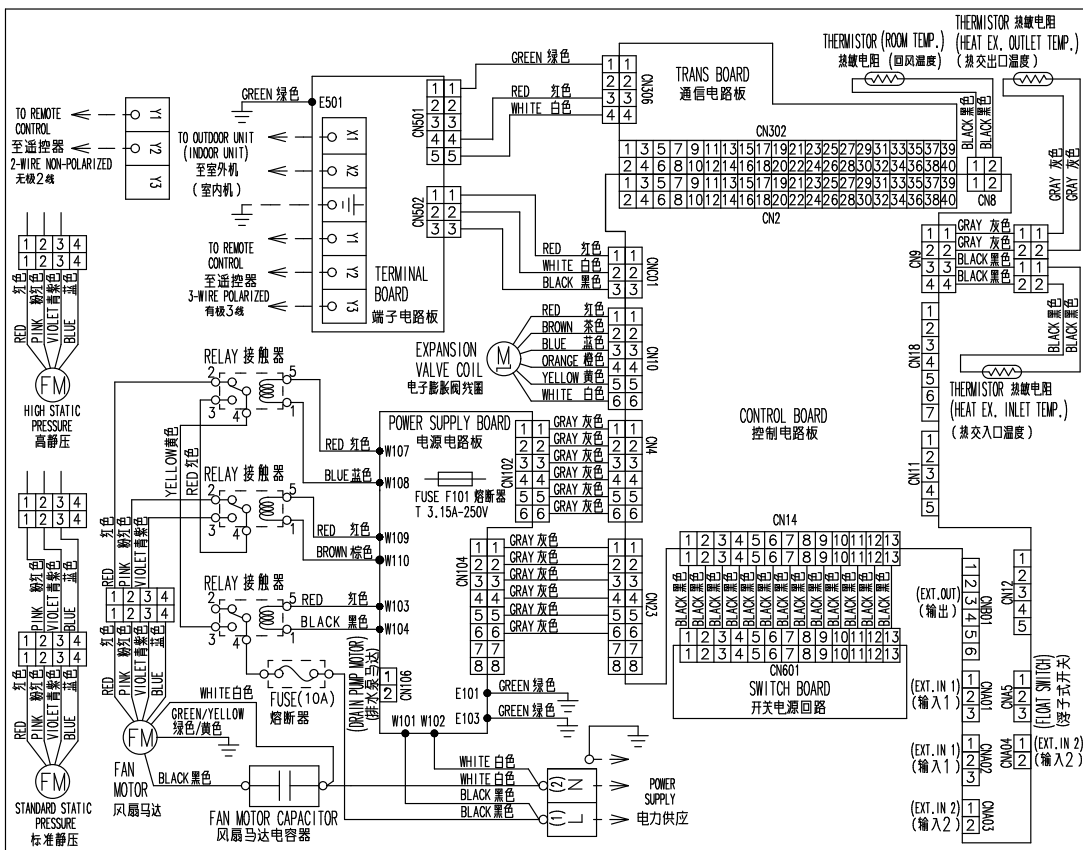

COMPACT SLIM DUCT TYPE

MODELS : ARXK004/ 007/ 009/ 012/ 014/ 018/ 024GLGH

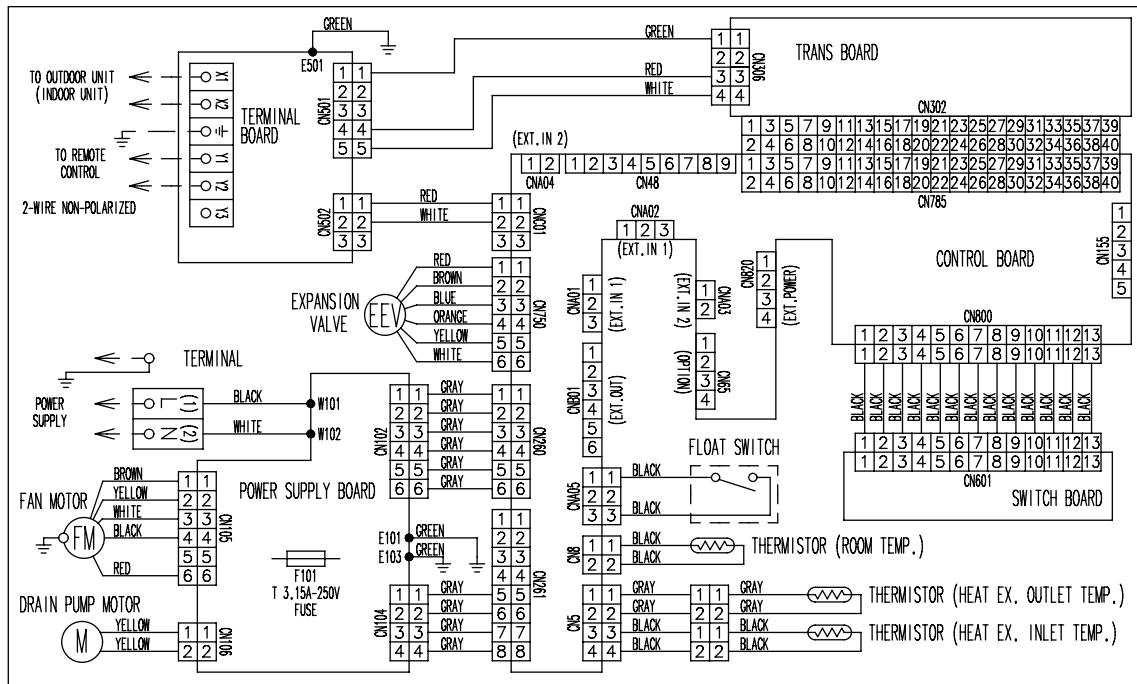

MODELS : AB *A12GATH, AB *A14GATH, AB *A18GATH, AB *A24GATH

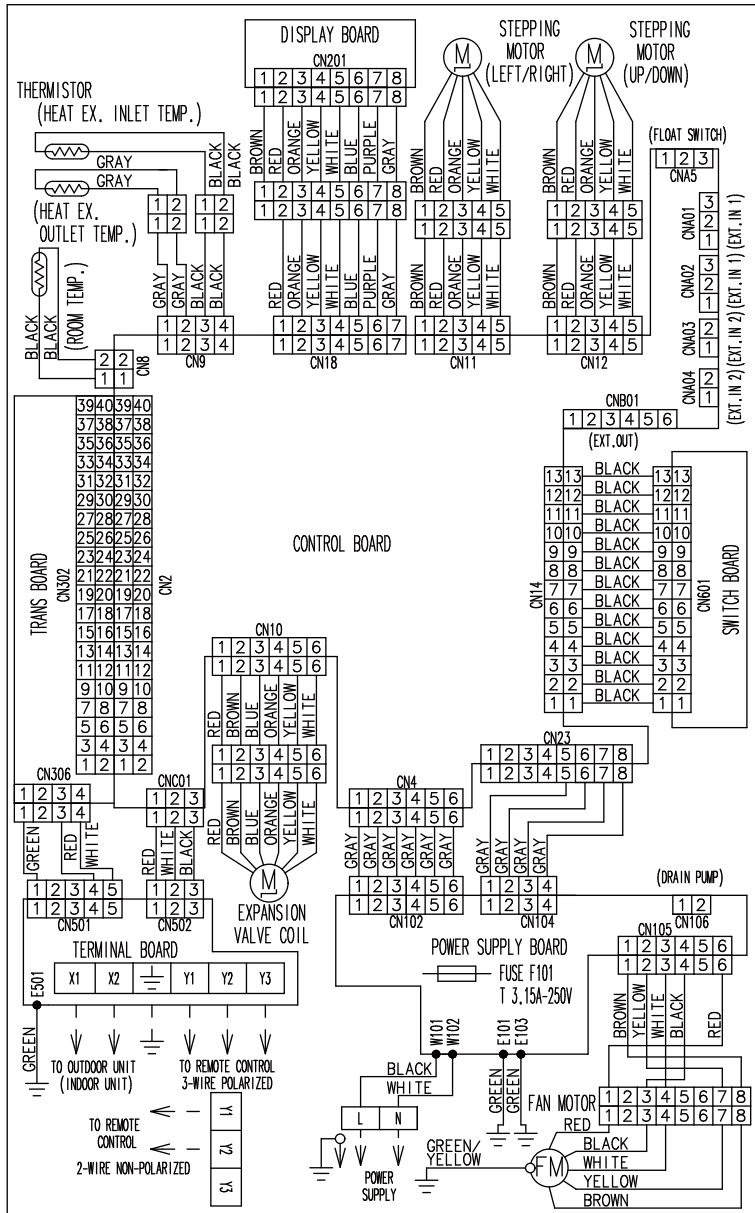

MODELS : AB *A30GATH, AB *A36GATH, AB *A45GATH, AB *A54GATH

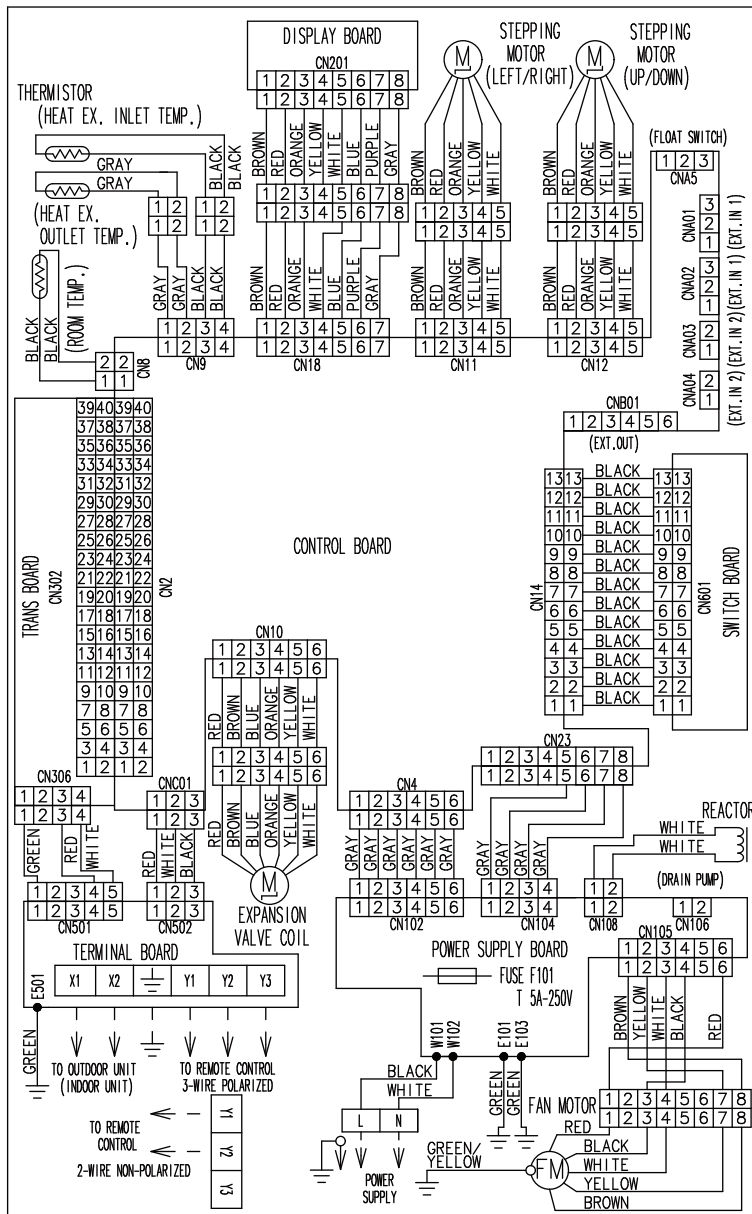

**MODELS : AS* A04GACH, AS* A07GA* H, AS* A09GA* H,
AS* A12GA* H, AS* A14GA* H**

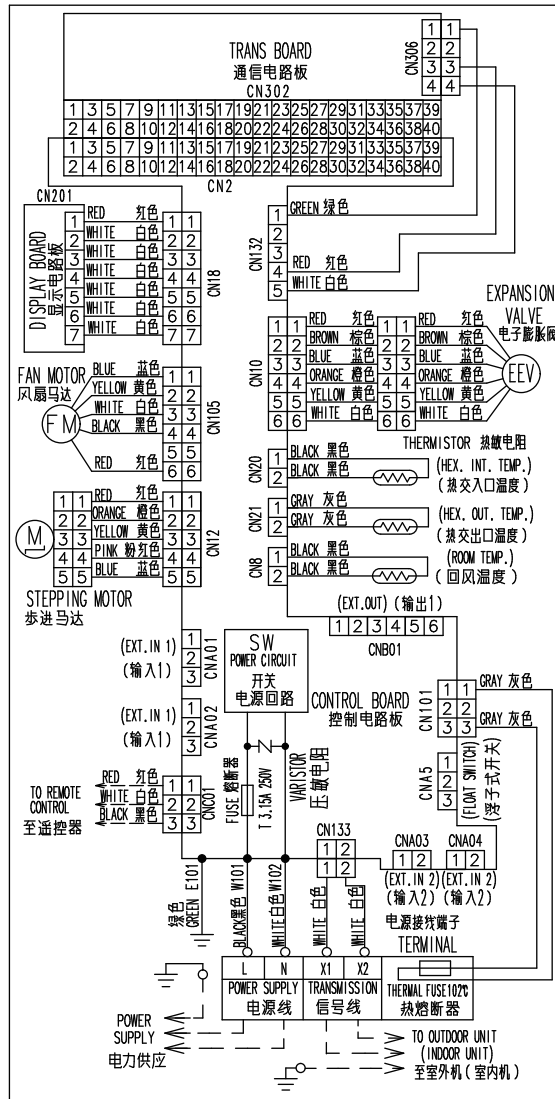

MODELS : AS *E04GACH, AS *E07GACH, AS *E09GACH, AS *E12GACH, AS *E14GACH

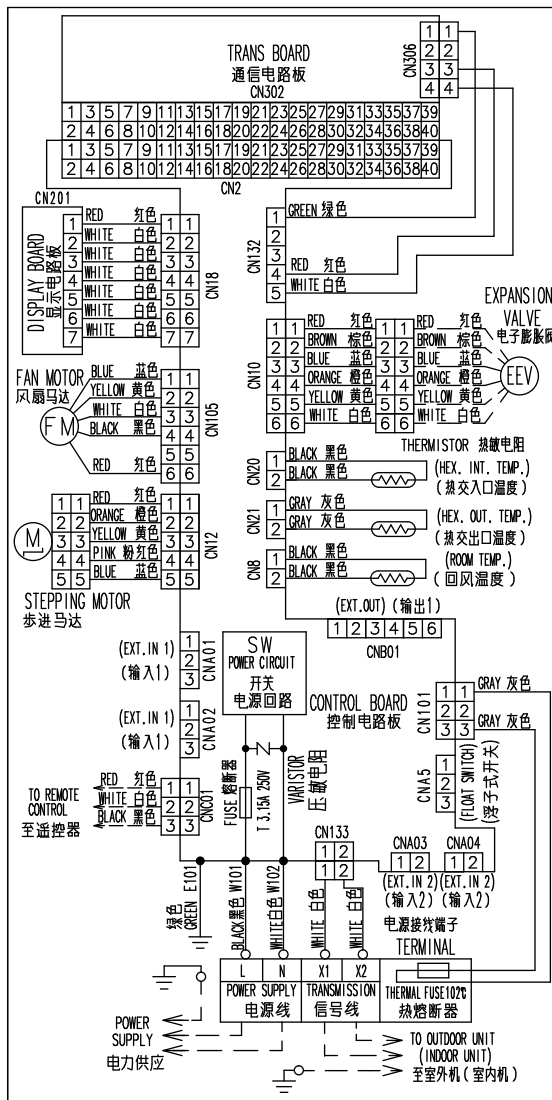

MODELS : AS* A18GA* H, AS* A24GA* H, AS* A30GA* H

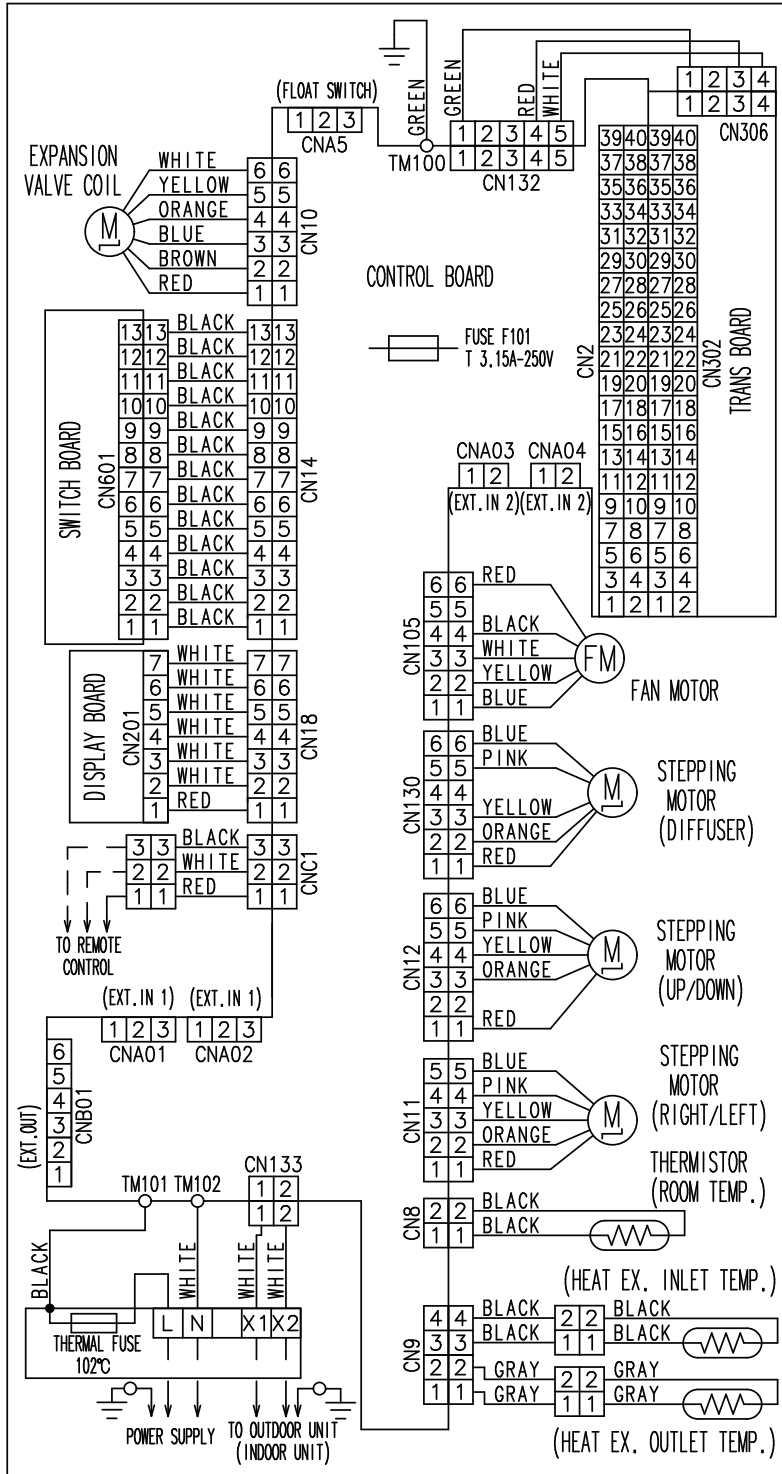

COMPACT WALL MOUNTED TYPE (EEV internal)

MODELS : ASYA004/ 007/ 009GTAH
 ASHA004/ 007/ 009GTAH

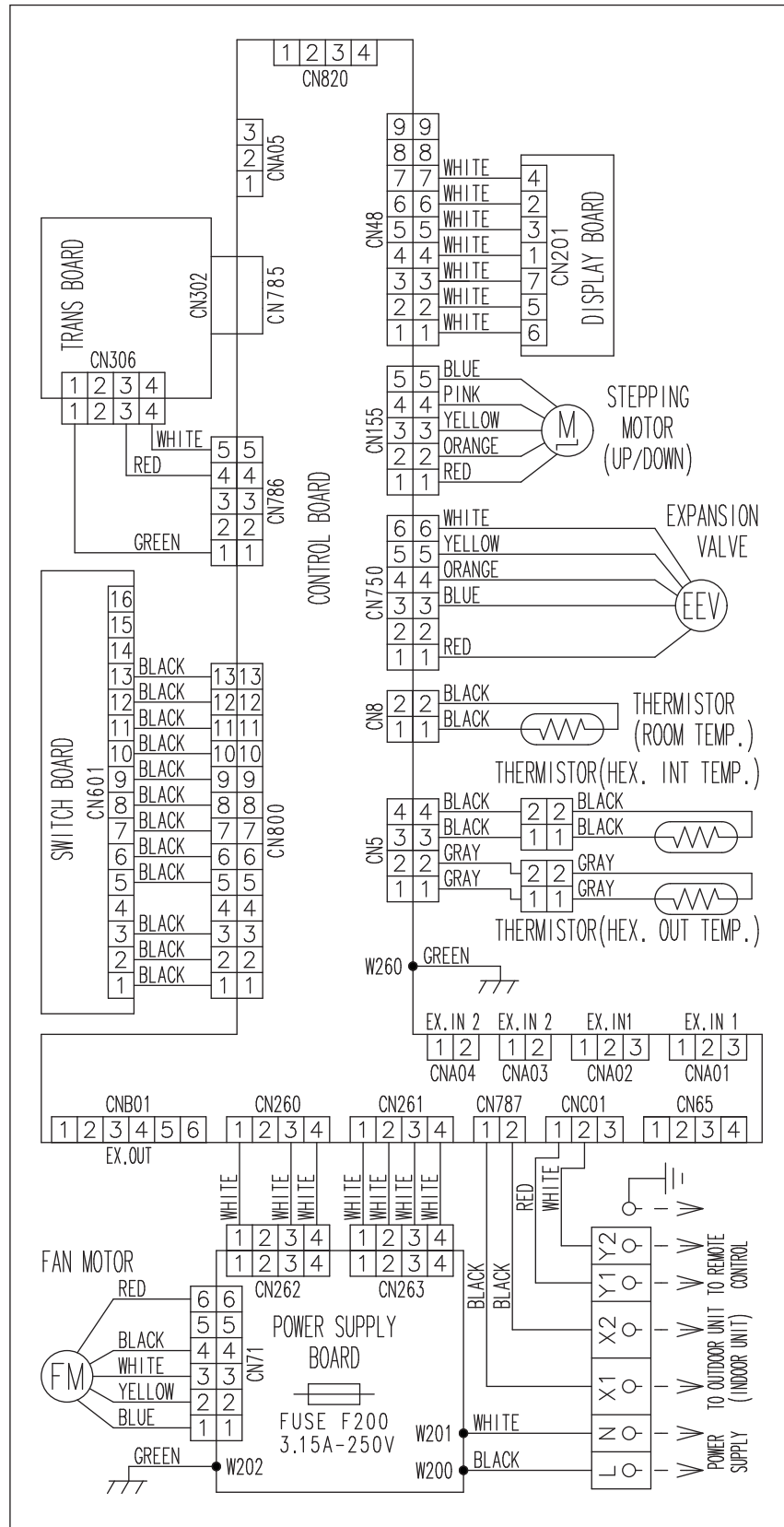

COMPACT WALL MOUNTED TYPE (EEV external)

MODELS : ASYE004/ 007/ 009GTAH
ASHE004/ 007/ 009GTAH

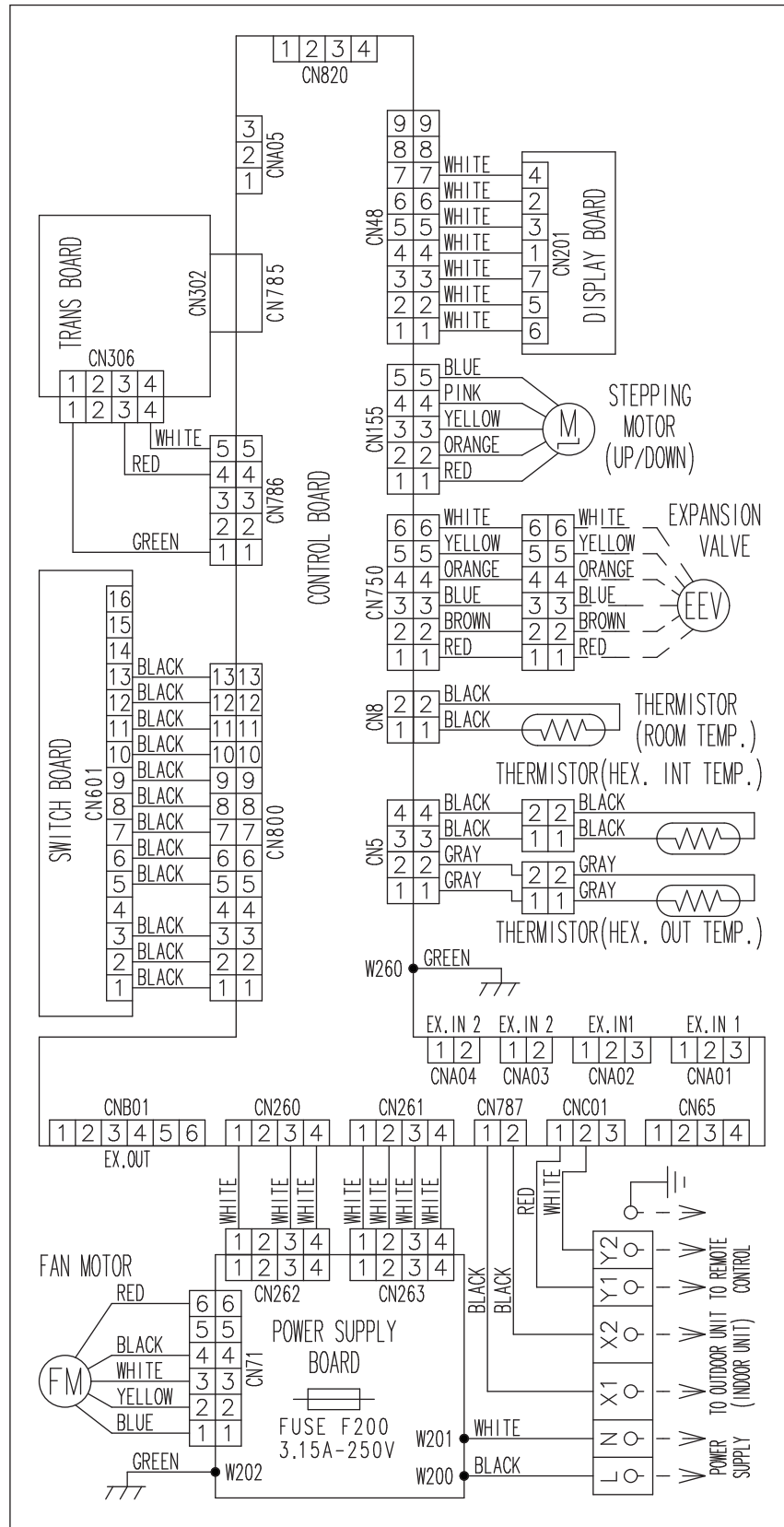

WALL MOUNTED TYPE

**MODELS : ASYA18/ 24/ 30GACH, ASHA18/ 24/ 30GACH
 ASYA18/ 24/ 30GBCH, ASHA18/ 24/ 30GBCH**

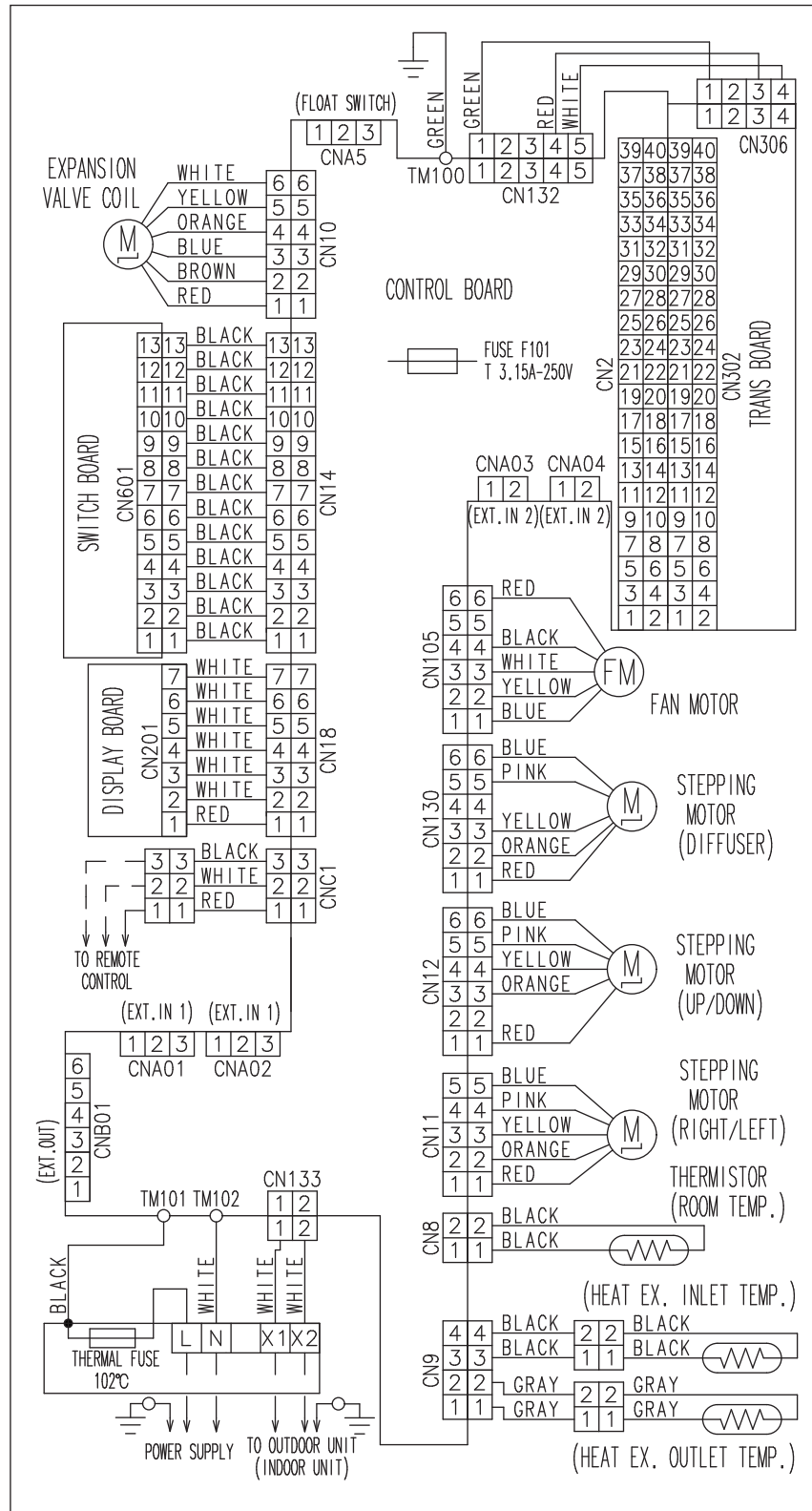

MODELS : ASYA030/ 034GTAH ASHA030/ 034GTAH

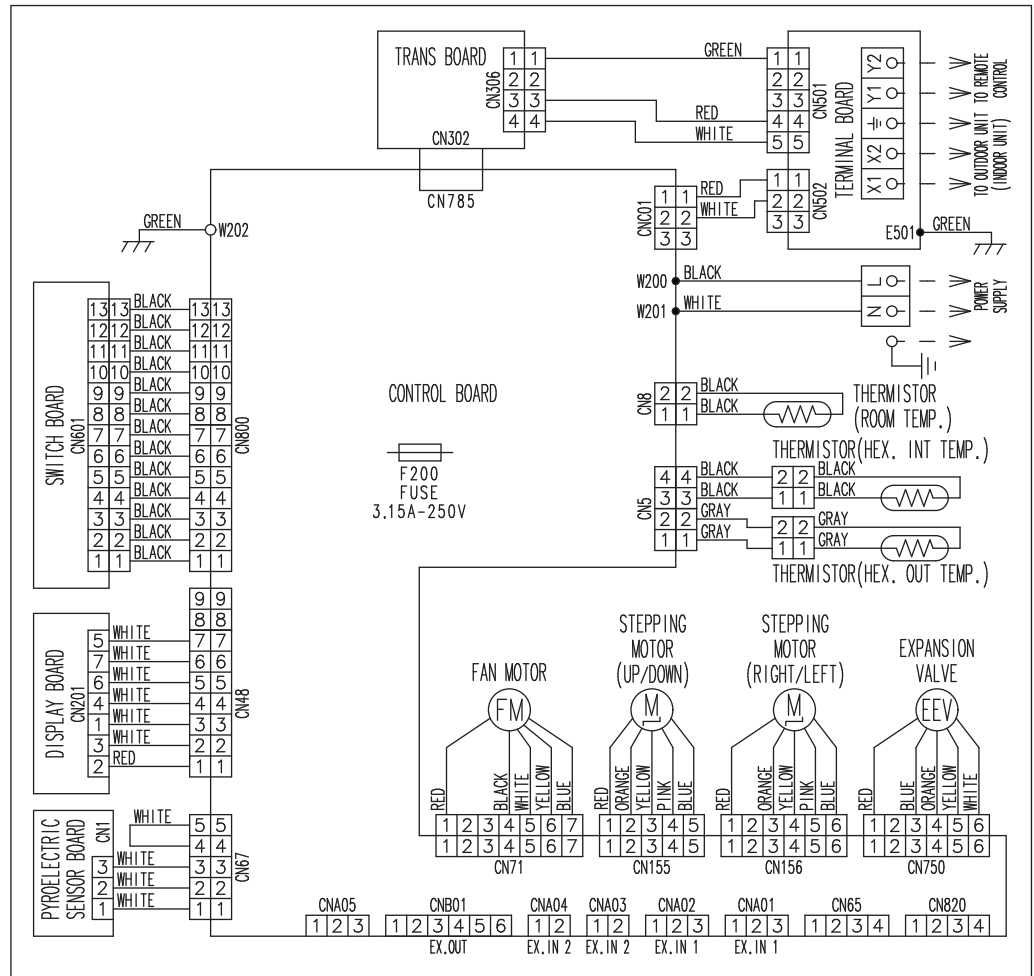

COMPACT FLOOR TYPE (EEV internal)

MODELS : AGYA004/ 007/ 009/ 012/ 014GCAH
 AGHA004/ 007/ 009/ 012/ 014GCAH

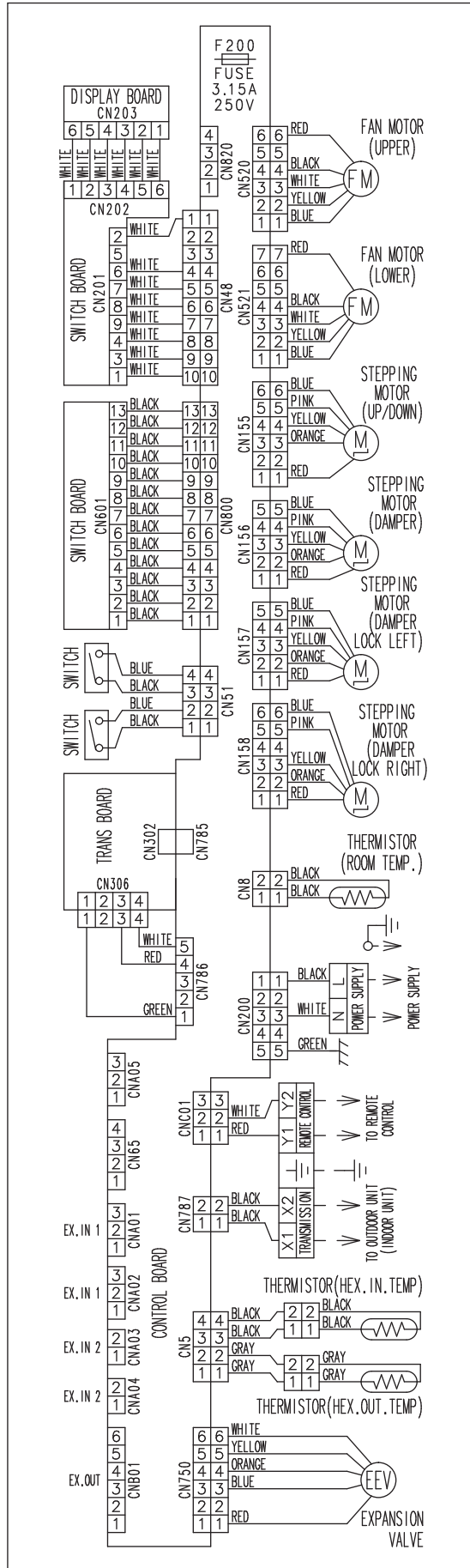

COMPACT FLOOR TYPE (EEV external)

MODELS : AGYE004/ 007/ 009/ 012/ 014GCAH
 AGHE004/ 007/ 009/ 012/ 014GCAH

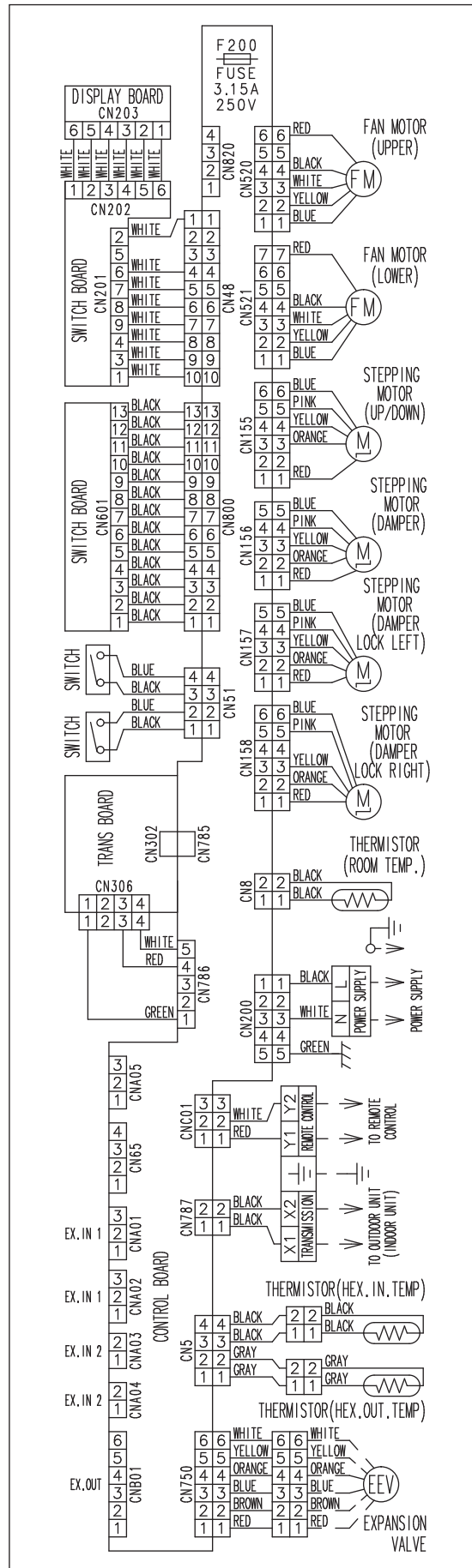

5-2-2 Outdoor Unit

MODELS : AJ*040/ 045LCLAH

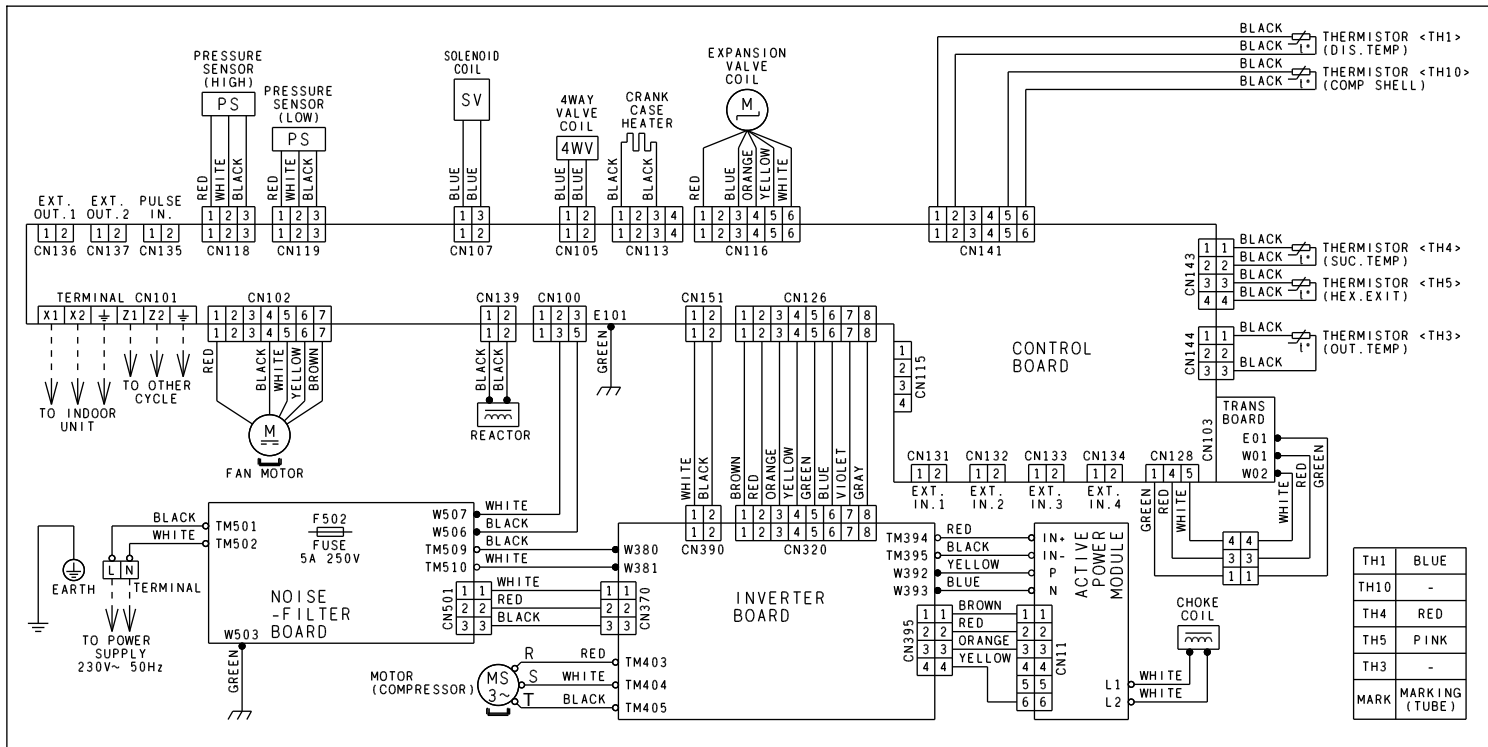

MODELS : AJ*054LCLAH

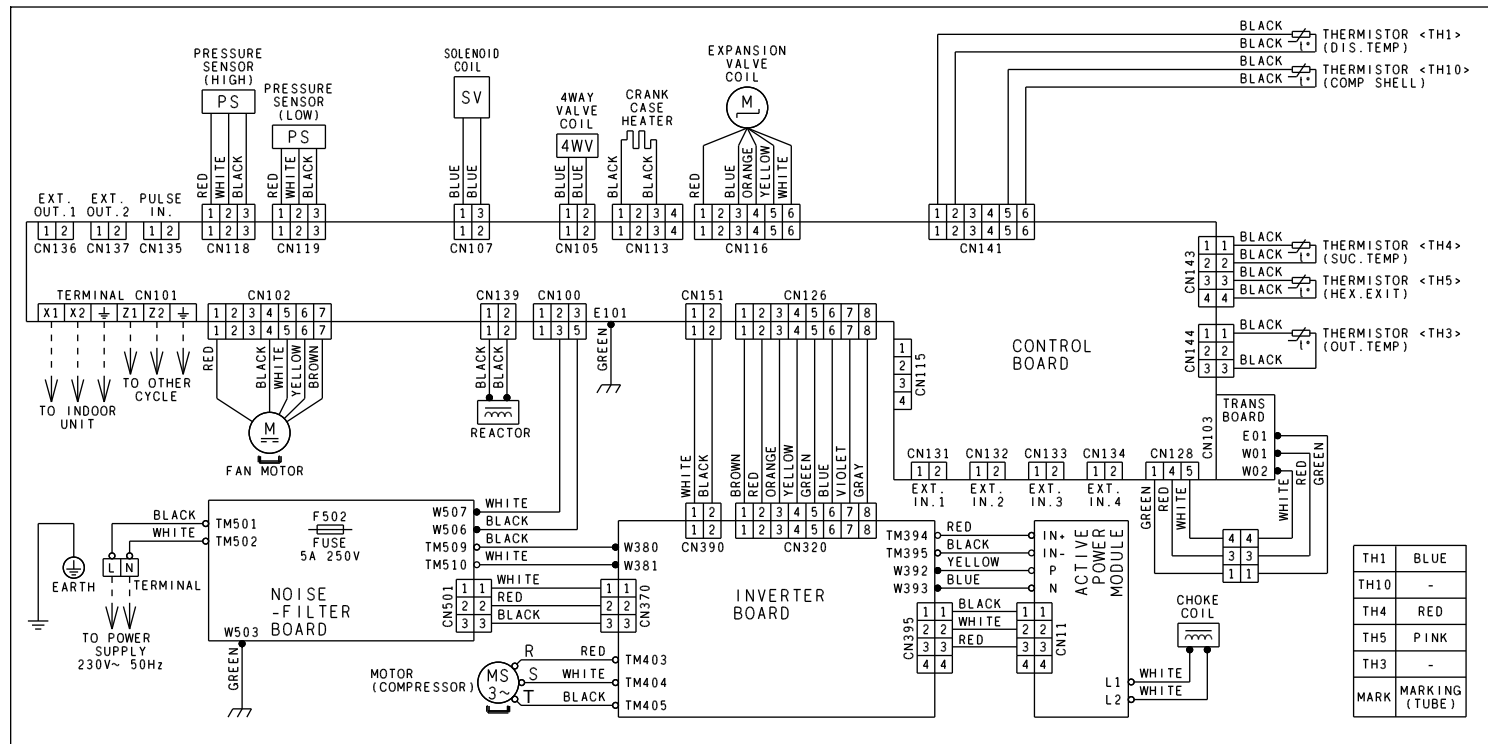

5-2-3 Outdoor Air Unit

MODELS : ARXH054GTAH, ARQH140GTAH

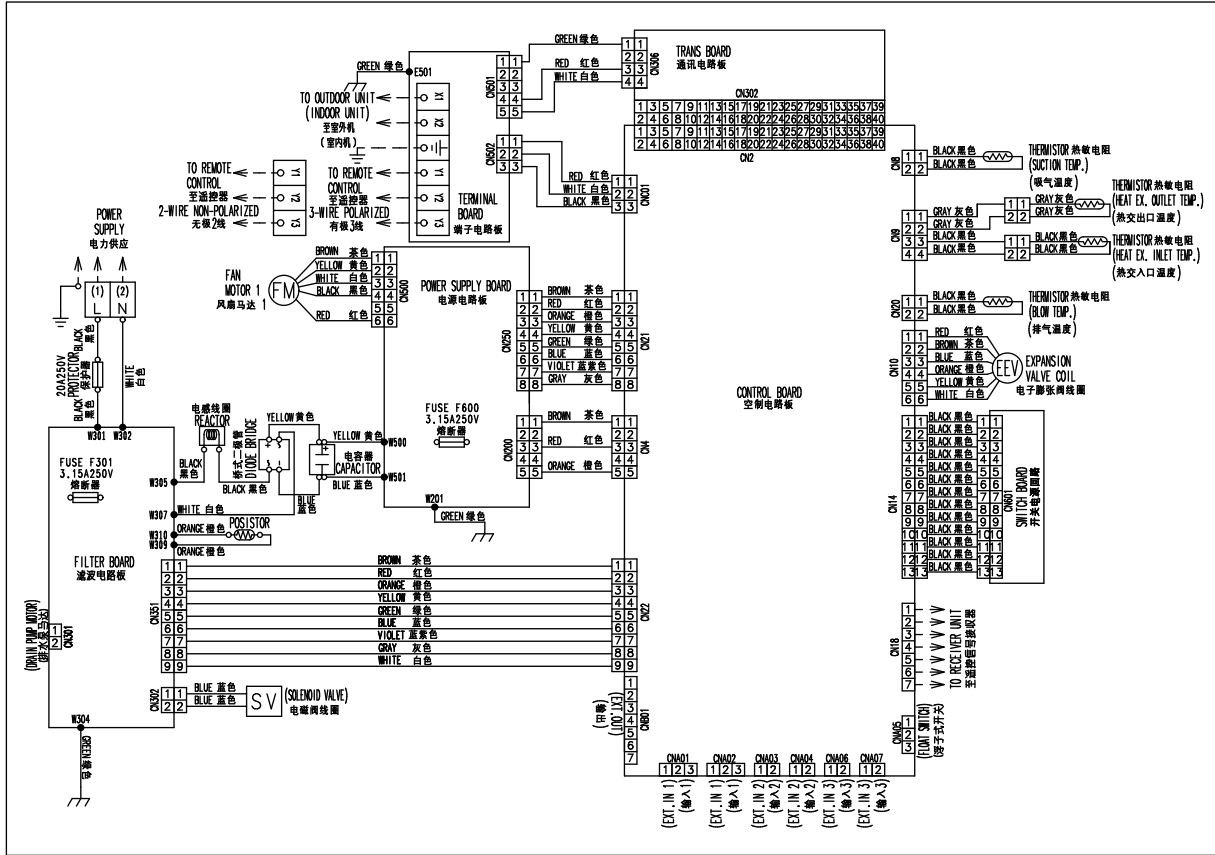

MODELS : ARXH072GTAH, ARQH224GTAH

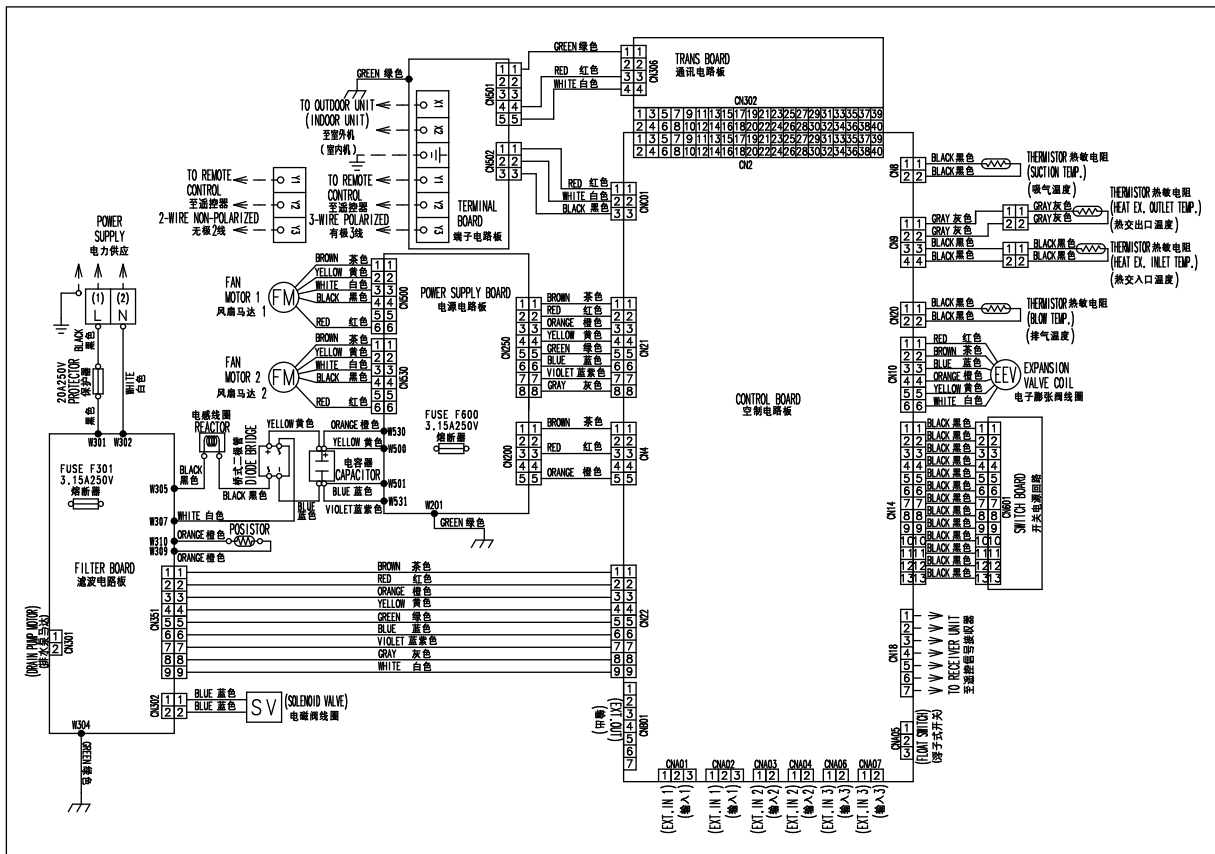

MODELS : ARXH096GTAH, ARQH280GTAH

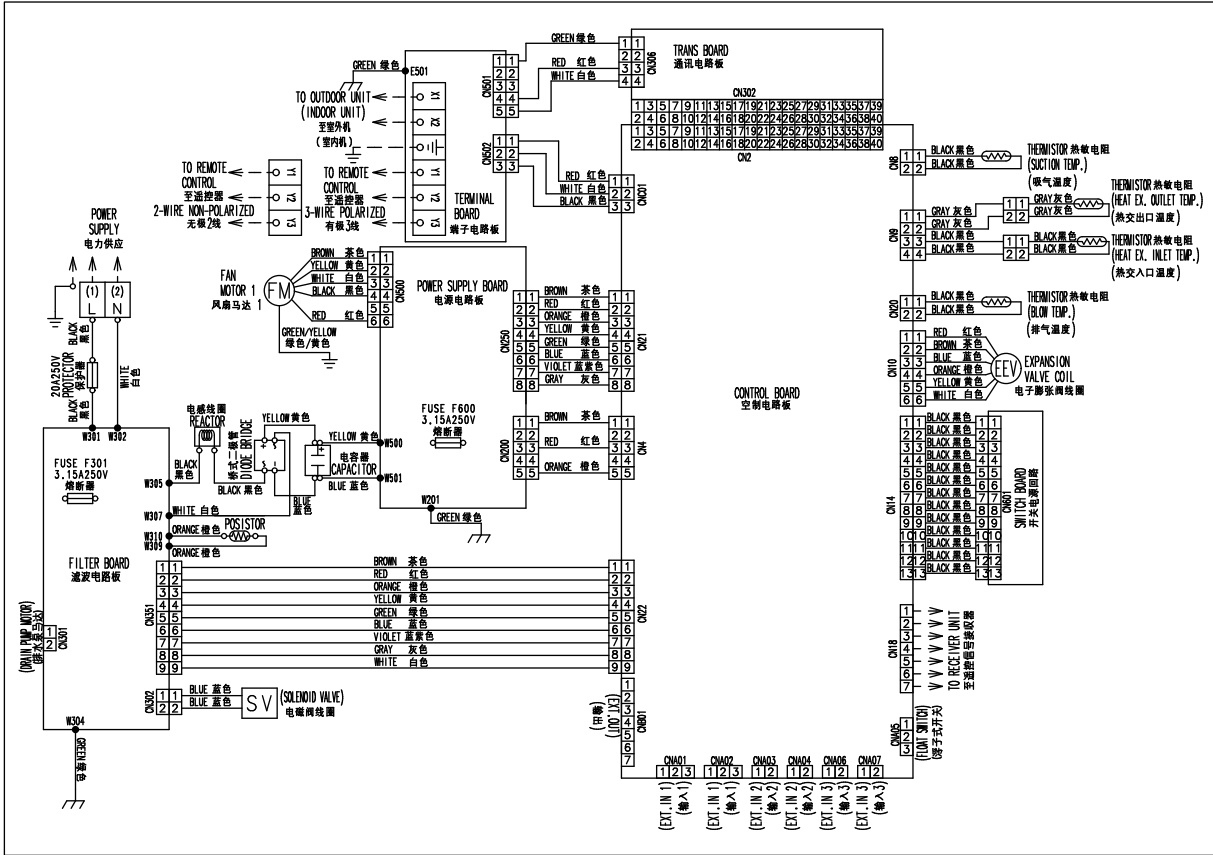

5-2-4 DX-KIT

1. REFRIGERANT CIRCUIT

MODELS: UTP-VX30A, UTP-VX60A, UTP-VX90A

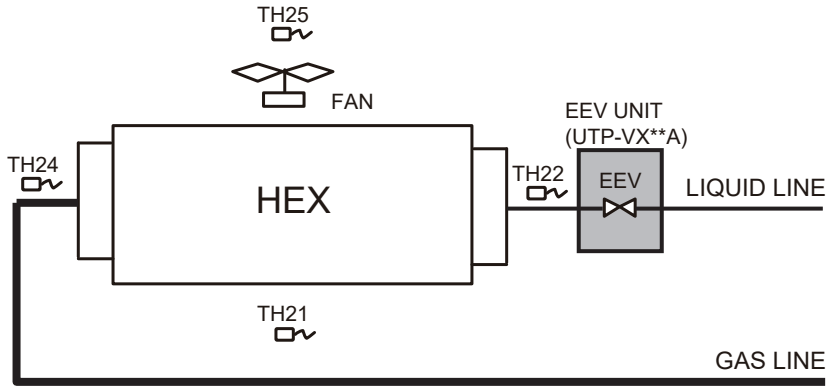

SYMBOL DESCRIPTION

MARK	DESCRIPTION
HEX	Heat exchanger (Locally purchased)
FAN	Fan (Locally purchased)
EEV	Electric expansion valve
TH21	Suction airflow temperature thermistor
TH22	Heat exchanger (inlet) thermistor
TH24	Heat exchanger (outlet) thermistor
TH25	Discharge airflow temperature thermistor

2. WIRING DIAGRAMS

MODEL: UTY-VDGX

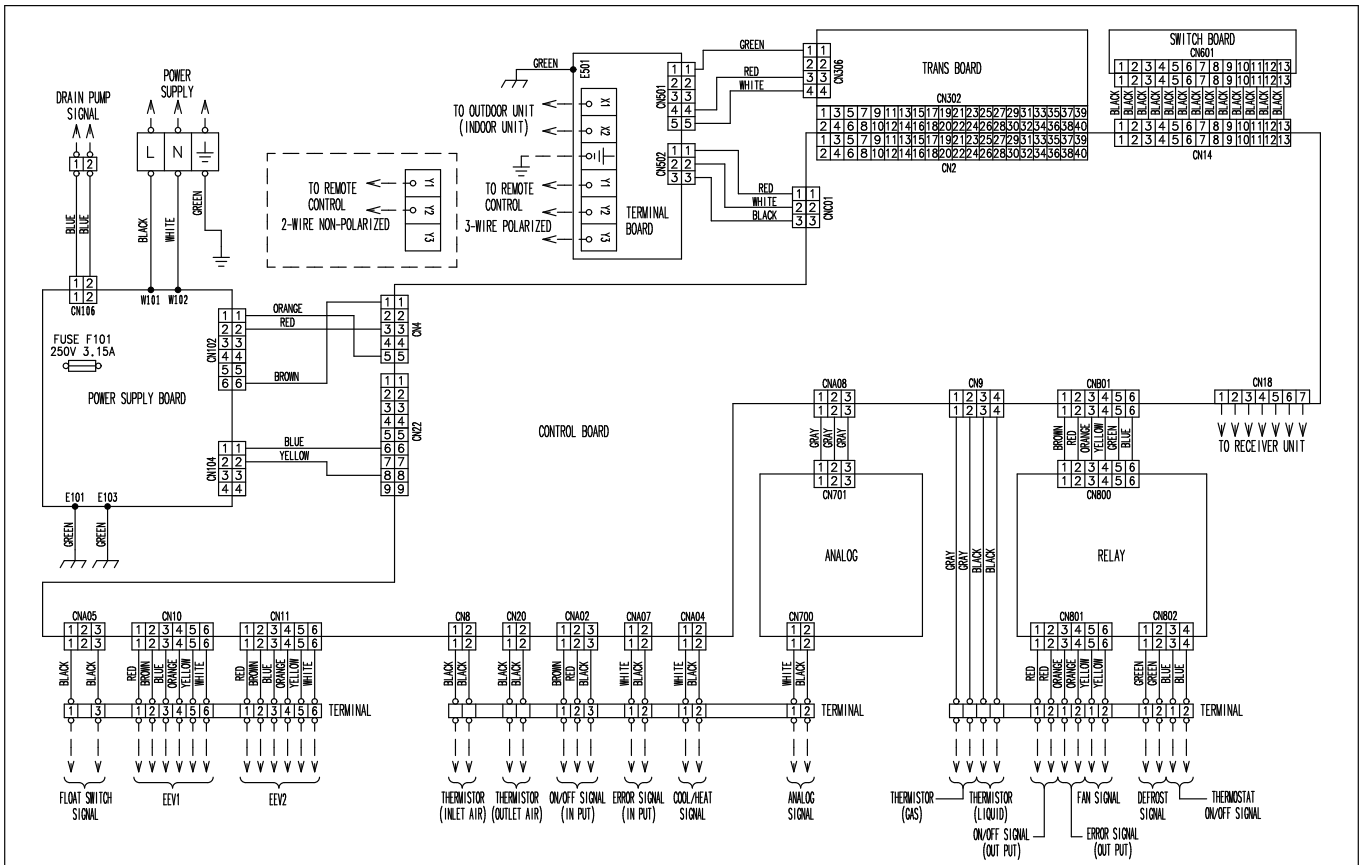

3. TERMINAL BLOCK LAYOUT

3rd row

				1	2	1	2	1	2	1	2	1	2
Thermistor (GAS)		Thermistor (LIQUID)		ON/OFF Signal (OUT PUT)		Error SIGNAL (OUT PUT)		FAN SIGNAL		DEFROST SIGNAL		THERMOSTAT ON/OFF SIGNAL	

2nd row

				1	2	3	1	2	1	2	1	2	
Thermistor (INLET AIR)		Thermistor (OUTLET AIR)		ON/OFF Signal (IN PUT)			ERROR SIGNAL (IN PUT)		COOL/HEAT SIGNAL		ANALOG SIGNAL		

1st row

1	2	1	2	3	4	5	6	1	2	3	4	5	6
FLOAT SW SIGNAL		EEV1						EEV2					

1	2	L	N	E
DRAIN PUMP OUTPUT		POWER SUPPLY		

X1	X2	E	Y1	Y2	Y3
TRANSMISSION TO OUTDOOR UNIT			TO REMOTE-CONTROL		

5-3 CHARACTERISTICS OF SENSORS

5-3-1 Pressure sensor

1. Discharge Pressure Sensor - Pressure Sensor (HIGH): CN118 -

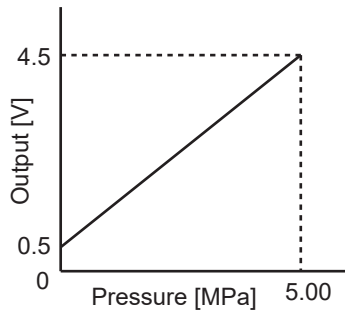

With the connector connected to the PCB, measure the voltage between CN118 : 2-3 of the Main PCB.

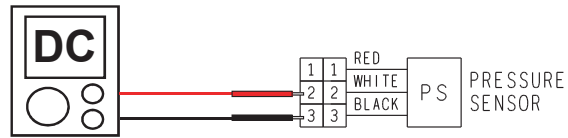

Pressure (MPa)	0.00	0.10	0.20	0.30	0.40	0.50	0.70	0.80	0.90	1.00	1.20	1.40	1.60	1.80	2.00
Output (V)	0.50	0.58	0.66	0.74	0.82	0.90	1.06	1.14	1.22	1.30	1.46	1.62	1.78	1.94	2.10
Pressure (MPa)	2.20	2.40	2.60	2.80	3.00	3.20	3.40	3.60	3.80	4.00	4.20	4.40	4.60	4.80	5.00
Output (V)	2.26	2.42	2.58	2.74	2.90	3.06	3.22	3.38	3.54	3.70	3.86	4.02	4.18	4.34	4.50

2. Suction Pressure Sensor - Pressure Sensor (Low): CN119 -

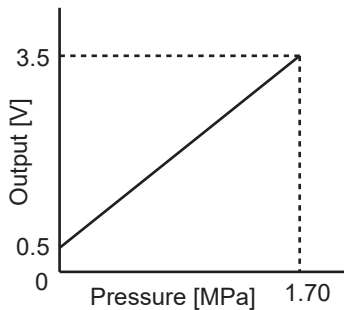

With the connector connected to the PCB, measure the voltage between CN119 : 2-3 of the Main PCB.

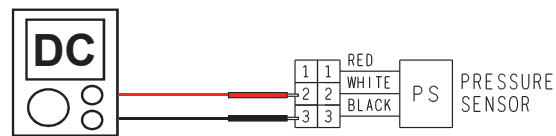

Pressure (MPa)	0.00	0.10	0.20	0.30	0.40	0.50	0.70	0.80	0.90	1.00	1.10	1.20
Output (V)	0.50	0.68	0.85	1.03	1.21	1.38	1.74	1.91	2.09	2.27	2.44	2.62
Pressure (MPa)	1.30	1.40	1.50	1.60	1.70							
Output (V)	2.79	2.97	3.15	3.32	3.50							

5-3-2 Thermistor resistance

Thermistor resistance value <Outdoor unit side>

Temperature [°C]	Resistance Value [kΩ]		
	Thermistor A	Thermistor B	Thermistor C
- 20	---	---	105.4
- 10	---	27.8	58.2
- 5	---	21.0	44.0
0	168.6	16.1	33.6
5	129.8	12.4	25.9
10	100.9	9.6	20.2
15	79.1	7.6	15.8
20	62.6	6.0	12.5
25	49.8	4.8	10.0
30	40.0	3.8	8.0
40	26.3	2.5	5.3
50	17.8	1.7	3.6
60	12.3	1.2	---
70	8.7	---	---
80	6.3	---	---
90	4.6	---	---
100	3.4	---	---
110	2.6	---	---
120	2.0	---	---
Applicable Thermistors	Discharge temp. TH : [TH1] Comp temp. TH : [TH10]	Heat exchanger. TH : [TH5] Suction temp. TH : [TH4]	Outdoor temp. TH : [TH3]

Thermistor resistance value <Indoor unit side>

Indoor Temperature Thermistor (TH21)

Temperature (°C)	0	5	10	15	20	25	30	35
Resistance Value (kΩ)	33.6	25.9	20.2	15.8	12.5	10.0	8.0	6.5

Temperature (°C)	40	45
Resistance Value (kΩ)	5.3	4.3

Heat Exchanger Thermistor (Inlet TH22 / Outlet TH23)

Temperature (°C)	0	5	10	15	20	25	30	35
Resistance Value (kΩ)	168.6	129.8	100.9	79.1	62.5	49.8	40.0	32.4

Temperature (°C)	40	45	50	55	60
Resistance Value (kΩ)	26.3	21.6	17.8	14.8	12.3

5-3-3 Saturation temperature and saturation pressure tables (R410A)

(Pressure: Gauge pressure)

Temp. (°C)	Saturation pressure (Mpa)	
	Saturated liquid	Saturated gas
-30	0.1722	0.1717
-29	0.1836	0.1830
-28	0.1953	0.1947
-27	0.2074	0.2067
-26	0.2199	0.2192
-25	0.2328	0.2320
-24	0.2460	0.2452
-23	0.2597	0.2588
-22	0.2737	0.2728
-21	0.2882	0.2872
-20	0.3031	0.3021
-19	0.3185	0.3174
-18	0.3343	0.3331
-17	0.3505	0.3493
-16	0.3672	0.3659
-15	0.3844	0.3830
-14	0.4021	0.4006
-13	0.4202	0.4187
-12	0.4389	0.4373
-11	0.4580	0.4563
-10	0.4776	0.4759
-9	0.4978	0.4960
-8	0.5185	0.5166
-7	0.5398	0.5377
-6	0.5616	0.5594
-5	0.5839	0.5817
-4	0.6069	0.6045
-3	0.6304	0.6279
-2	0.6545	0.6519
-1	0.6791	0.6765
0	0.7044	0.7017
1	0.7303	0.7274
2	0.7569	0.7539
3	0.7840	0.7809
4	0.8119	0.8086
5	0.8403	0.8369
6	0.8695	0.8659
7	0.9000	0.8956
8	0.930	0.926
9	0.961	0.957
10	0.993	0.989
11	1.026	1.022
12	1.059	1.055
13	1.093	1.089
14	1.128	1.123
15	1.164	1.159
16	1.200	1.195
17	1.237	1.232

Temp. (°C)	Saturation pressure (Mpa)	
	Saturated liquid	Saturated gas
18	1.275	1.270
19	1.314	1.308
20	1.353	1.348
21	1.394	1.388
22	1.435	1.429
23	1.477	1.471
24	1.520	1.513
25	1.563	1.557
26	1.608	1.601
27	1.654	1.647
28	1.700	1.693
29	1.747	1.740
30	1.796	1.788
31	1.845	1.837
32	1.895	1.887
33	1.946	1.938
34	1.998	1.990
35	2.051	2.043
36	2.105	2.097
37	2.160	2.152
38	2.216	2.208
39	2.273	2.265
40	2.332	2.323
41	2.391	2.382
42	2.451	2.442
43	2.513	2.503
44	2.575	2.565
45	2.639	2.629
46	2.703	2.693
47	2.769	2.759
48	2.836	2.826
49	2.904	2.894
50	2.974	2.963
51	3.044	3.034
52	3.116	3.106
53	3.189	3.178
54	3.263	3.253
55	3.338	3.328
56	3.415	3.405
57	3.493	3.483
58	3.572	3.562
59	3.653	3.643
60	3.735	3.725
61	3.818	3.808
62	3.902	3.893
63	3.988	3.979
64	4.075	4.066
65	4.164	4.155

Saturation pressure (Mpa)	Saturation temperature (°C)	
	Saturated liquid	Saturated gas
0.0	-51.85	-51.83
0.1	-37.25	-37.21
0.2	-27.61	-27.55
0.3	-20.21	-20.14
0.4	-14.12	-14.04
0.5	- 8.89	- 8.80
0.6	- 4.30	- 4.20
0.7	- 0.17	- 0.06
0.8	3.58	3.69
0.9	7.02	7.15
1.0	10.22	10.35
1.1	13.21	13.34
1.2	16.01	16.15
1.3	18.66	18.80
1.4	21.17	21.31
1.5	23.55	23.70
1.6	25.83	25.98
1.7	28.01	28.16
1.8	30.10	30.25
1.9	32.11	32.26
2.0	34.04	34.20
2.1	35.91	36.06
2.2	37.72	37.87
2.3	39.46	39.62
2.4	41.16	41.31
2.5	42.80	42.95
2.6	44.40	44.55
2.7	45.95	46.10
2.8	47.47	47.62
2.9	48.94	49.09
3.0	50.38	50.53
3.1	51.78	51.93
3.2	53.16	53.30
3.3	54.50	54.63
3.4	55.81	55.94
3.5	57.09	57.22
3.6	58.35	58.48
3.7	59.58	59.70
3.8	60.79	60.91
3.9	61.98	62.09
4.0	63.14	63.25
4.1	63.99	64.38

5-3-4 Temperature and pressure of refrigerant (Graph)

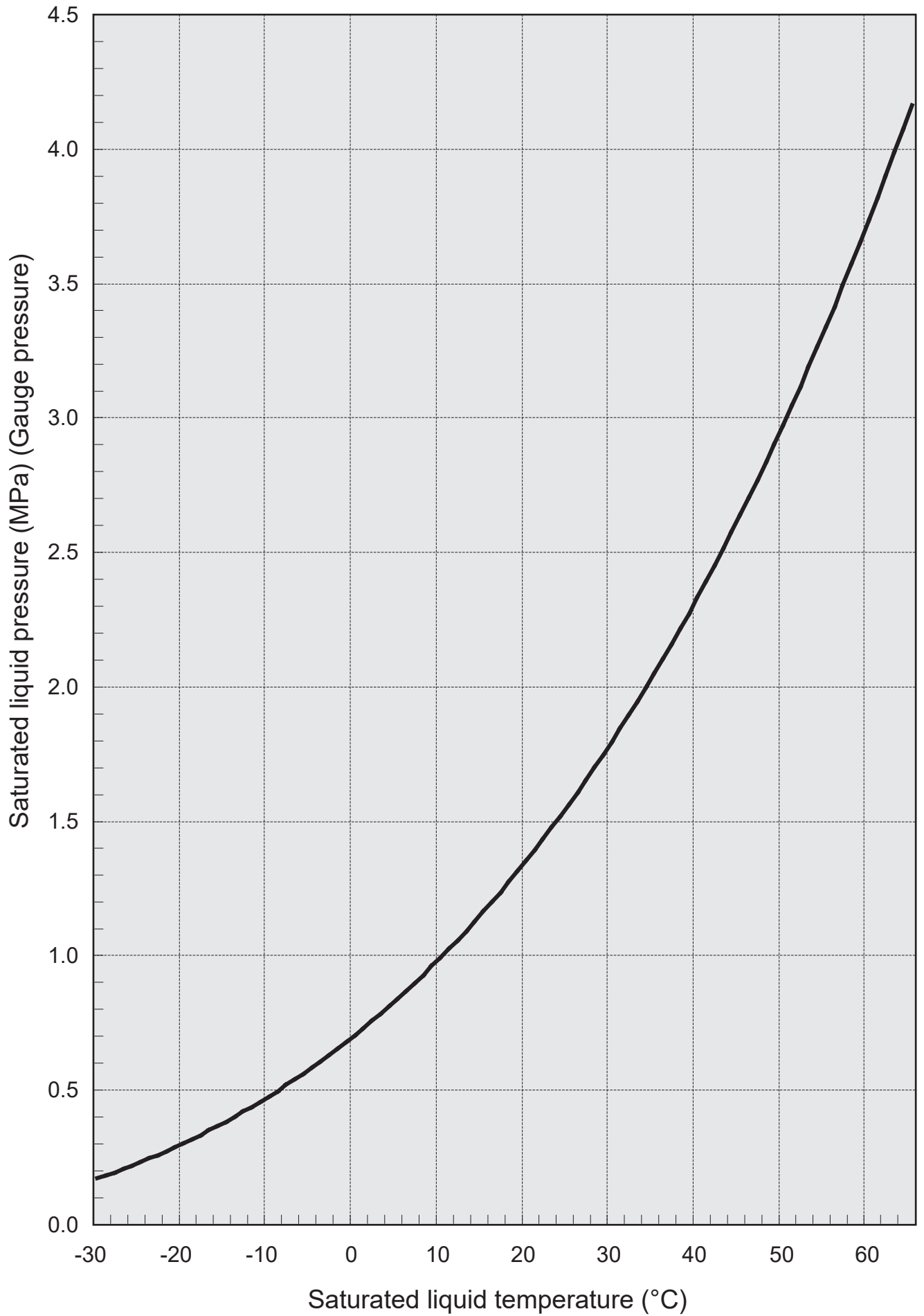

AIRSTAGE™ J-IIS

Variable Refrigerant Flow System

6. DISASSEMBLY PROCESS

6. DISASSEMBLY PROCESS

⚠ WARNING

Before servicing the unit, turn the power supply switch OFF,
Then, do not touch electric parts for 10 minutes due to the risk of electric shock.

1. Appearance



2. SERVICE PANEL removal

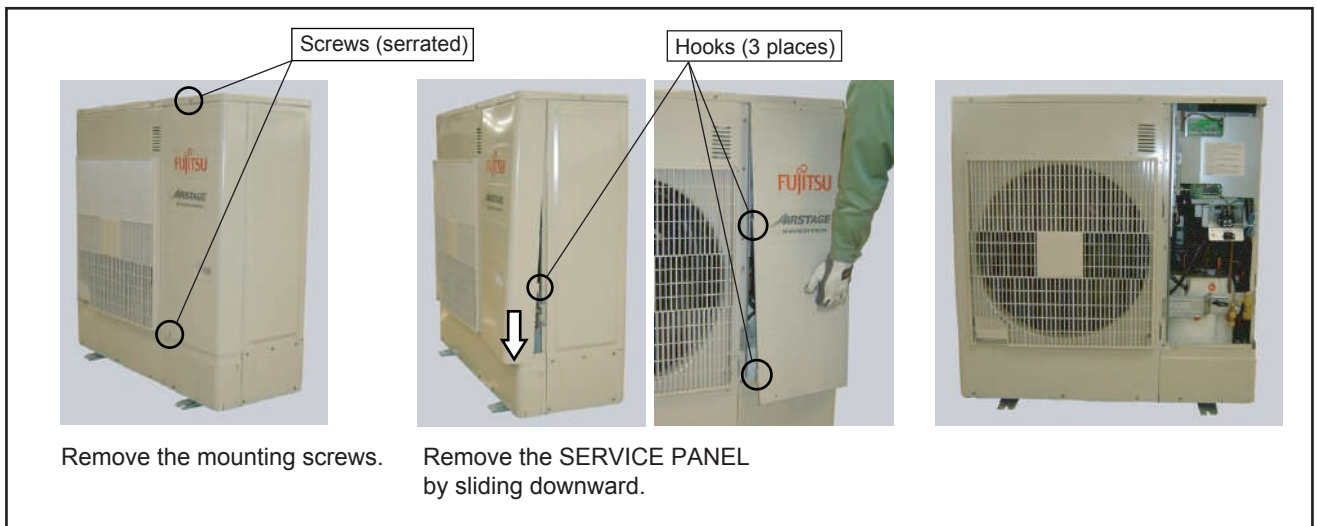

3. CONTROL COVER removal

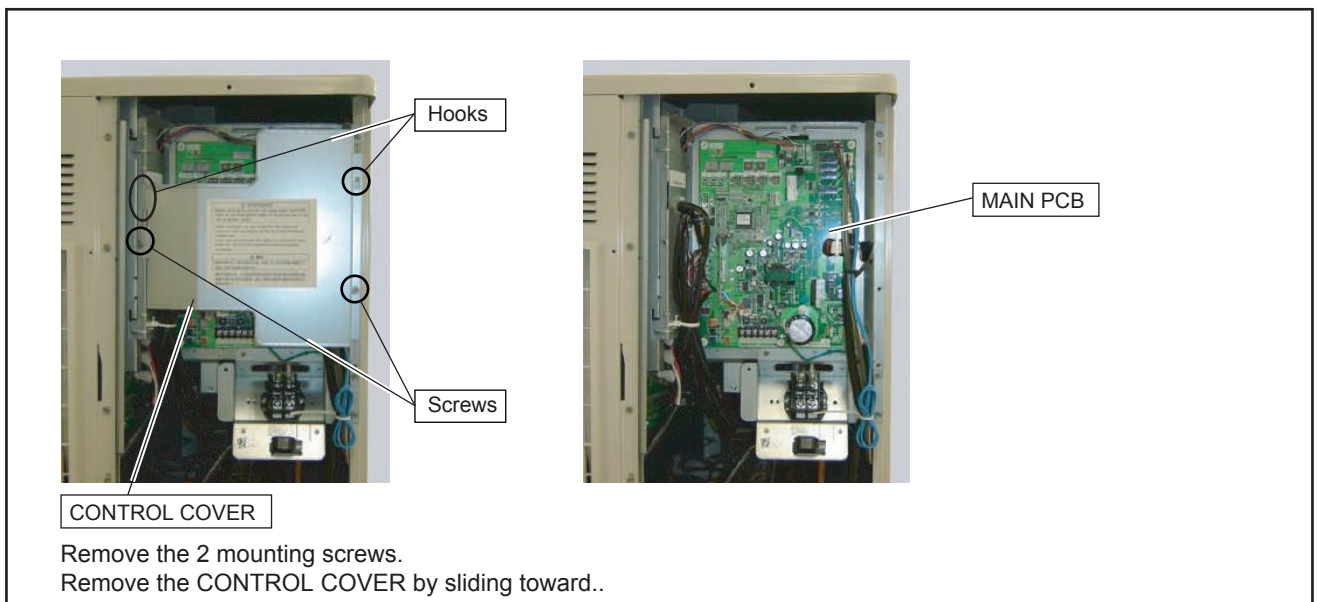

4. MAIN PCB removal

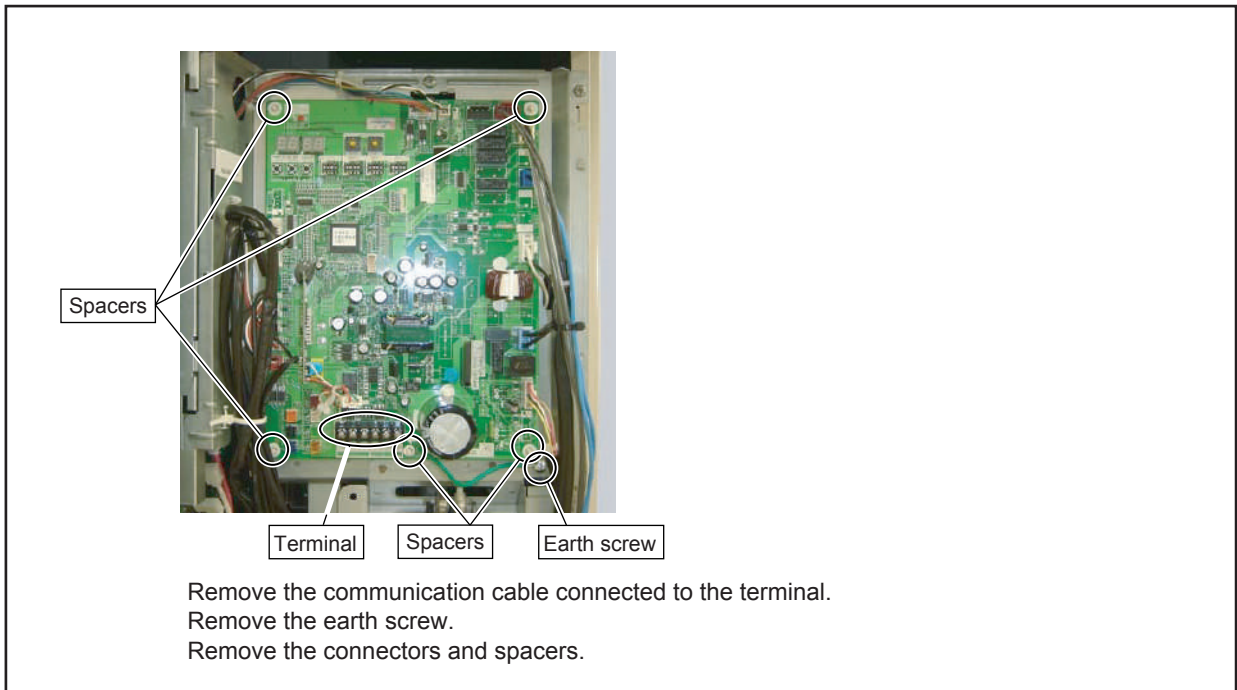

The diagram shows a green printed circuit board (PCB) mounted inside a metal chassis. Several components are highlighted with callouts: 'Spacers' at the top corners, 'Terminal' at the bottom center, 'Spacers' at the bottom center-right, and 'Earth screw' at the bottom right. Below the image, there are three lines of text: 'Remove the communication cable connected to the terminal.', 'Remove the earth screw.', and 'Remove the connectors and spacers.'

5. COMMUNICATION PCB removal

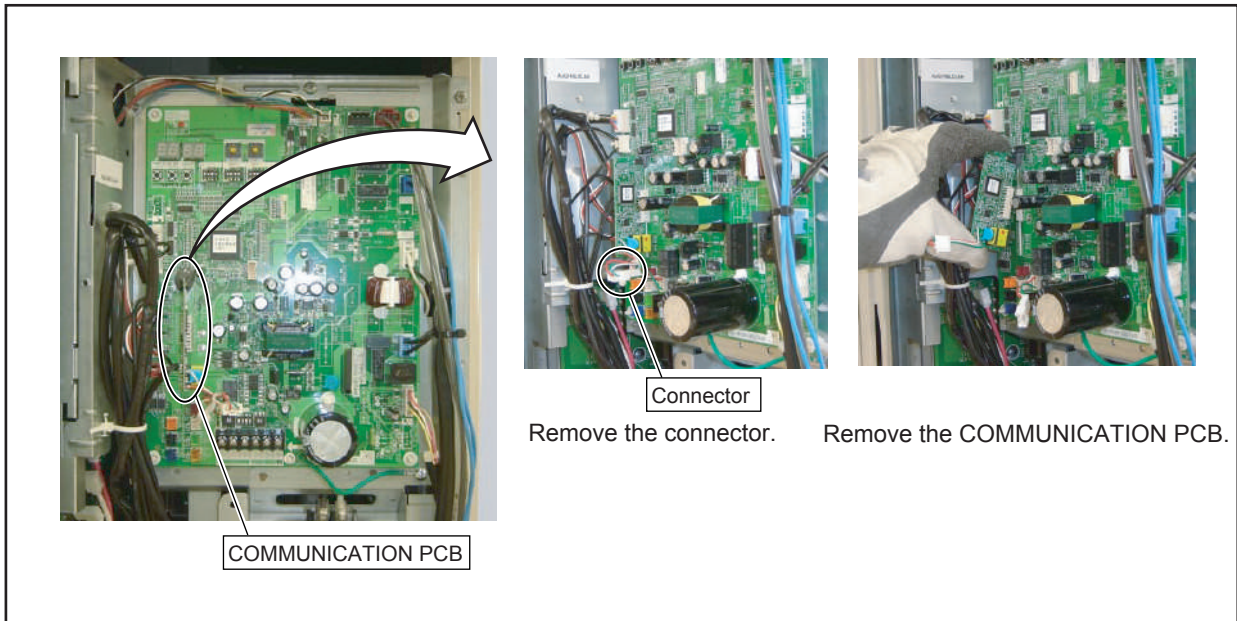

The diagram illustrates the removal of a communication PCB. It consists of three images. The first image on the left shows the communication PCB highlighted with a white oval and a curved arrow pointing to the right. A callout labeled 'COMMUNICATION PCB' points to this oval. The second image in the middle is a close-up of a component on the board, with a callout labeled 'Connector' pointing to it. The third image on the right shows a hand using a tool to lift the communication PCB out of the chassis. Below the images, there are two lines of text: 'Remove the connector.' and 'Remove the COMMUNICATION PCB.'

6. INVERTER PCB, FILTER PCB and ACTPM removal

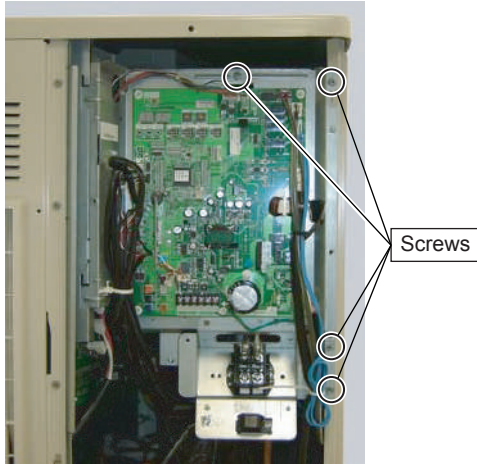

Remove the 4 mounting screws

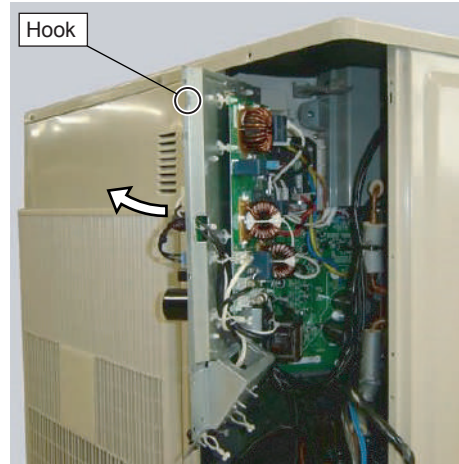

Open the CONTROL BOX (MAIN).

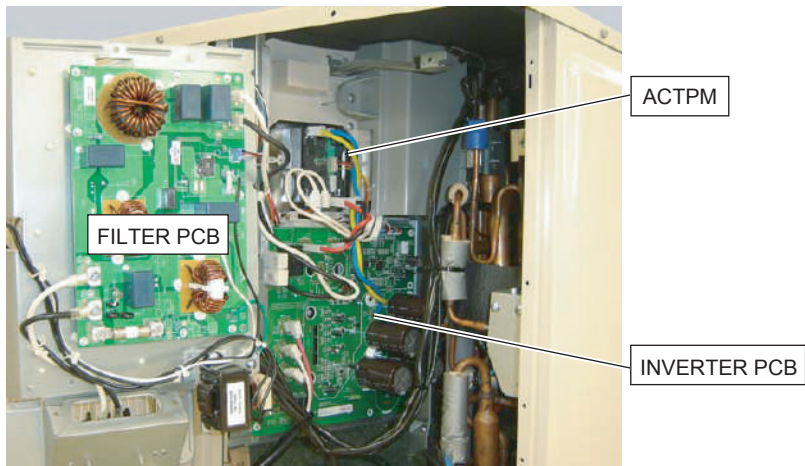

6-1. FILTER PCB removal

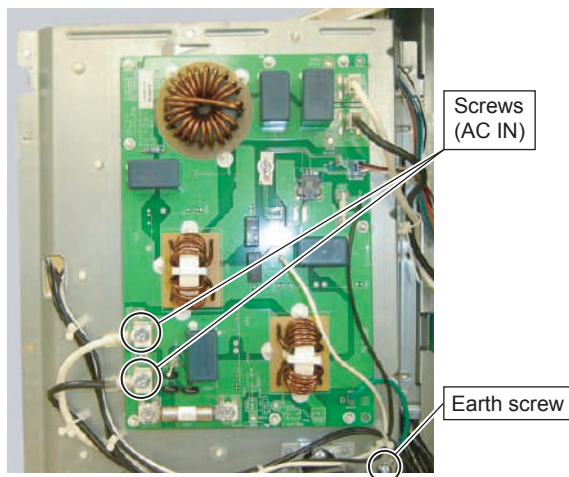

Remove the connectors and screws.

Note the tightening torque at the installation.
Tightening torque is $2.5 \pm 0.2\text{N}\cdot\text{m}$.
(except for the earth screw)

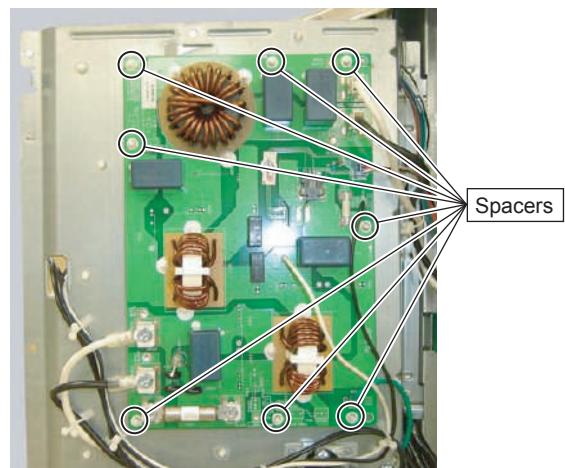

Remove the spacers.
(8 places)

6-2. INVERTER PCB removal

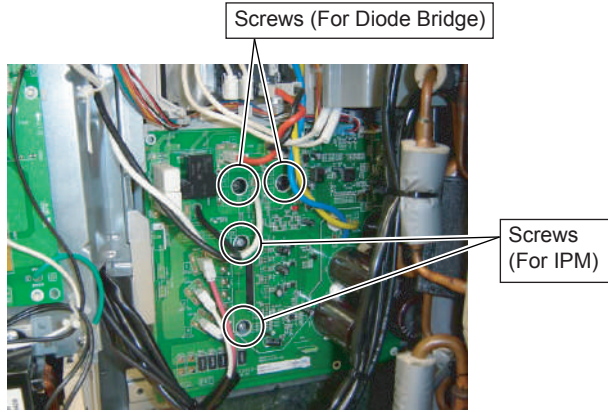

Remove the 4 mounting screws.

For screws of IPM.

Note the tightening torque at the installation.

1. Temporary tightening : 0.2 to 0.4N·m
2. Final tightening : 0.98 to 1.47N·m

For screws of Diode Bridge.

Note the tightening torque at the installation.

1. Temporary tightening : 0.2 to 0.4N·m
2. Final tightening : 0.5 to 0.8N·m

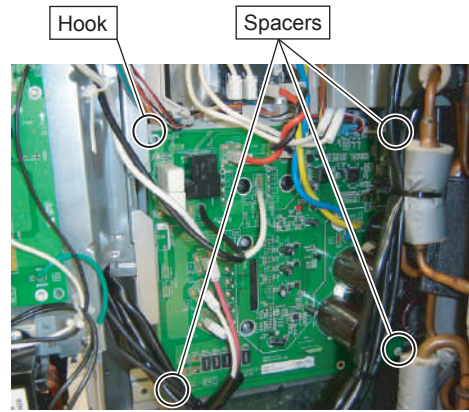

Remove the connectors and spacers.

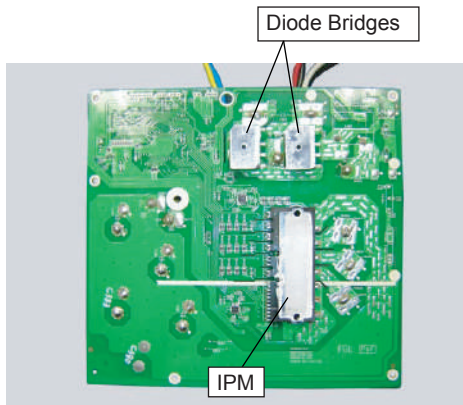

Spread the heat transfer compound on IPM and Diode Bridges when you exchange INVERTER PCB by the repair.

Note at the installation.

1. Remove the old heat transfer compound as possible from IPM and Diode Bridges when you exchange INVERTER PCB by the repair.
2. Spread the heat transfer compound evenly on IPM and Diode Bridges.
3. Prevent foreign matter from attaching to the surface of IPM and Diode Bridges.

Specifications for the heat transfer compound

- Manufacturer : Shin-Etsu Chemical Co.,Ltd
- Grade : G746

6-3. ACTPM removal

[AJ*040/ 045LCLAH]



Remove the connectors.

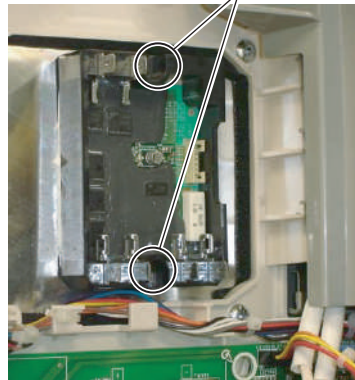

Remove the screws.

For screws of ACTPM.
Note the tightening torque at the installation.
1. Temporary tightening : 0.2 to 0.4N·m
2. Final tightening : 0.6 to 0.9N·m



Remove the ACTPM.

Spread the heat transfer compound on ACTPM when you exchange ACTPM by the repair.

[AJ*054LCLAH]

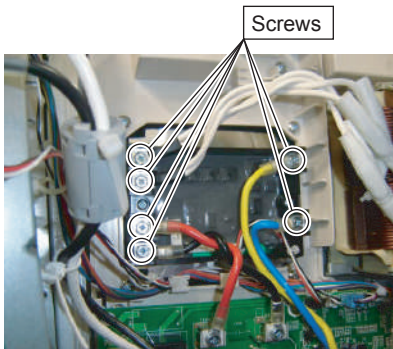

Remove the screws.
Remove the wires.

Note the tightening torque at the installation.
Tightening torque is 1.27 to 1.47N·m.

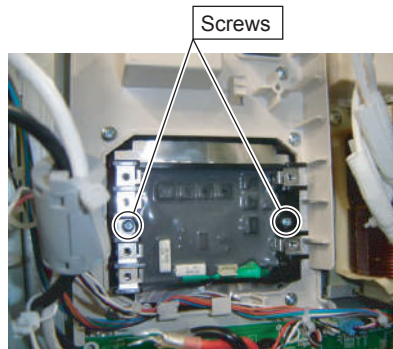

Remove the screws.

For screws of ACTPM.
Note the tightening torque at the installation.
1. Temporary tightening : 0.2 to 0.4N·m
2. Final tightening : 0.6 to 0.9N·m



Remove the ACTPM.

Spread the heat transfer compound on ACTPM when you exchange ACTPM by the repair.

Note at the installation.

1. Remove the old heat transfer compound as possible from ACTPM when you exchange ACTPM by the repair.
2. Spread the heat transfer compound evenly on ACTPM.
3. Prevent foreign matter from attaching to the surface of ACTPM.

Specifications for the heat transfer compound
- Manufacturer : Shin-Etsu Chemical Co.,Ltd
- Grade : G746

7. SOLENOID COIL removal

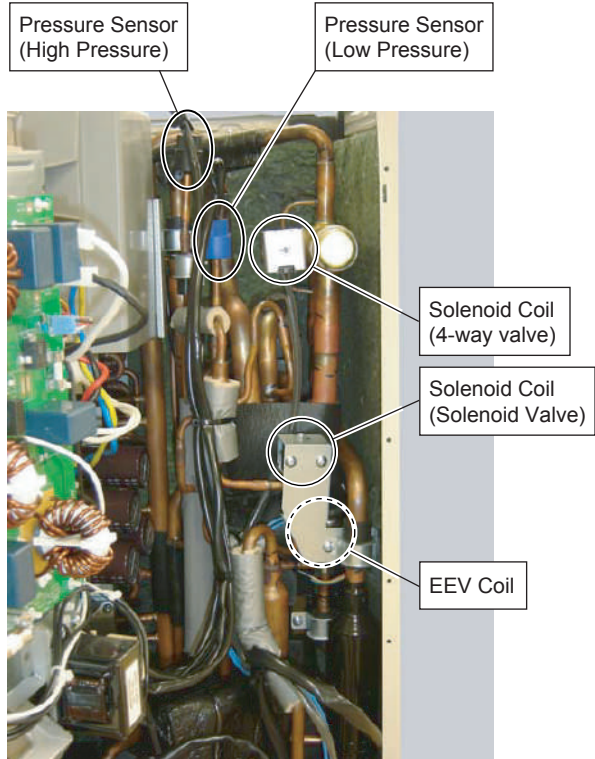

7-1. SOLENOID COIL (4way valve) removal

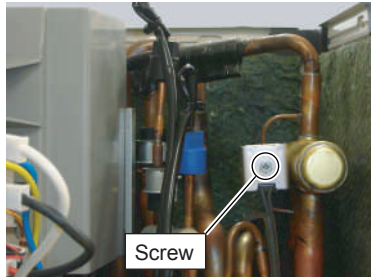

Remove the mounting screw.



Remove the SOLENOID COIL.

7-2. SOLENOID COIL (Solenoid valve) removal

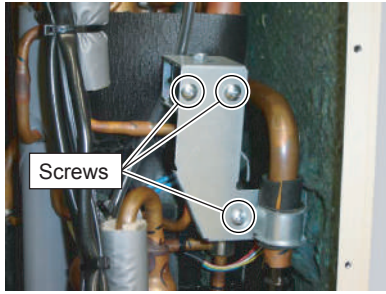

Remove the 3 mounting screws.

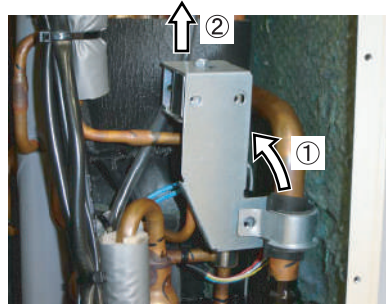

Remove the BRACKET (Solenoid valve)

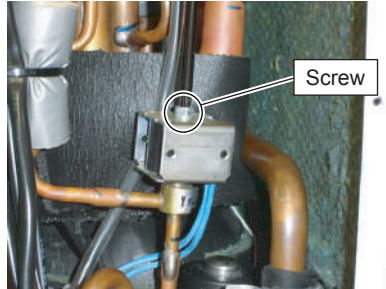
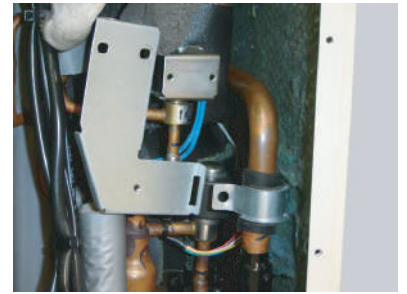

Remove the mounting screw.



Remove the SOLENOID COIL.

8. EEV COIL removal

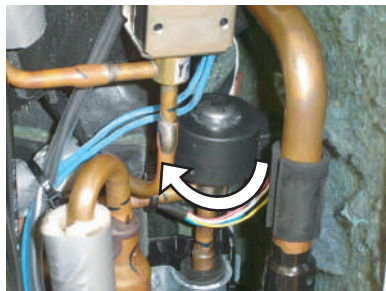

Turn the EEV coil.

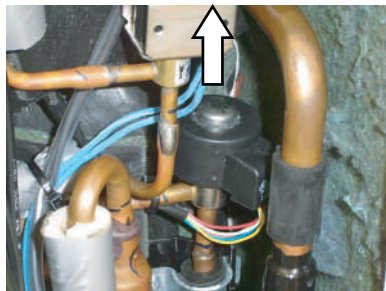

Remove the EEV coil.



9. FAN MOTOR removal

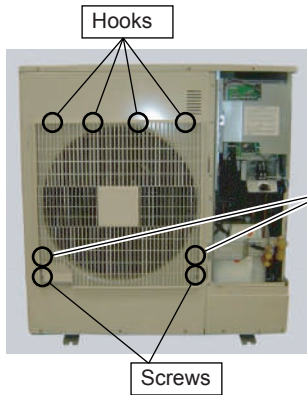

Remove the 2 mounting screws.

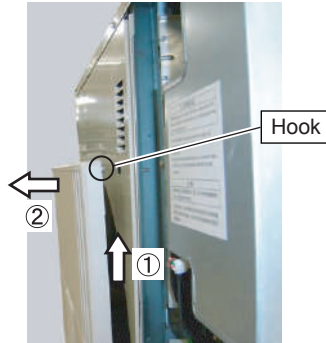

Remove the FAN GUARD



Remove the nut.
And remove the PROPELLER FAN.
Note at the installation.
Insert propeller Fan and Moter shaft reference
D cutting position.
And the tightening torque at the installation.
Tightening torque is from 10 to 12N·m.

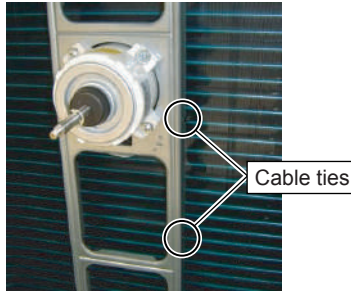

Cut the cable ties.(2 places)



Loose the wire clamp, and
remove the lead wires.

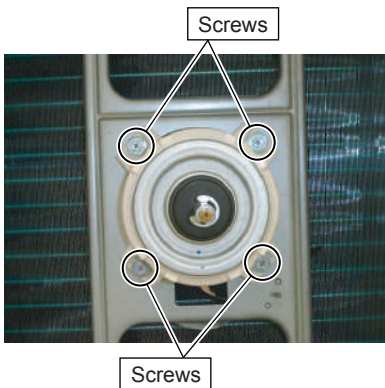

Remove the 4 mounting screws.
Remove the FAN MOTOR.
Note at the installation.
Motor wire is underside of Fan motor.

10. TOP PANEL removal

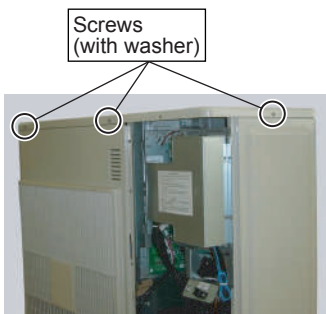

Remove the mounting screws.

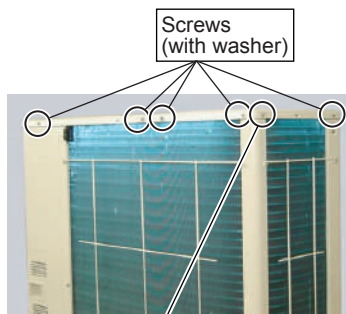

Screw (serrated)



Remove the TOP PANEL.

11. CHOKE COIL removal

[AJ*040/ 045LCLAH]

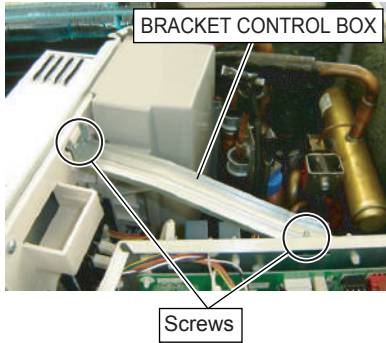

Remove the mounting screws.
Remove the BRACKET CONTROL BOX.

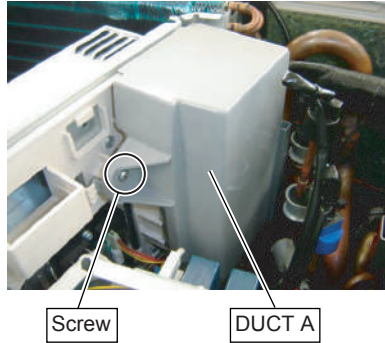

Remove the mounting screw.

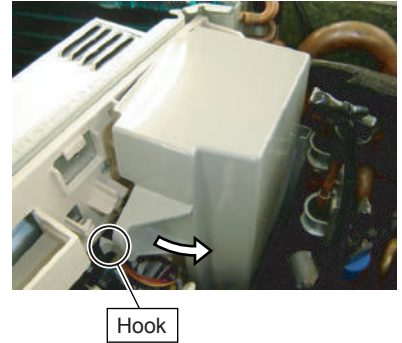

Remove the DUCT A.

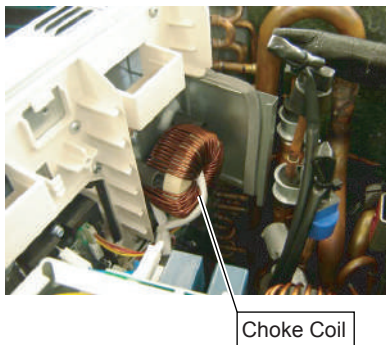

Choke Coil

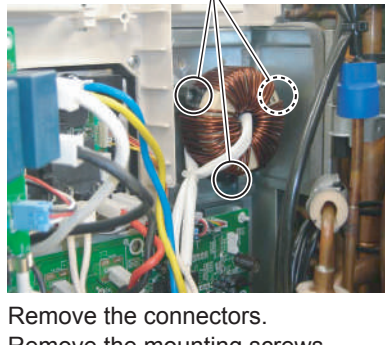

Remove the connectors.
Remove the mounting screws.
Remove the CHOKE COIL.

[AJ*054LCLAH]

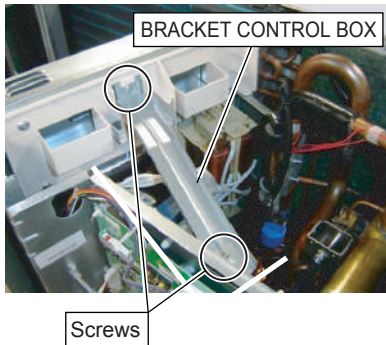

Remove the mounting screws.
Remove the BRACKET CONTROL BOX.

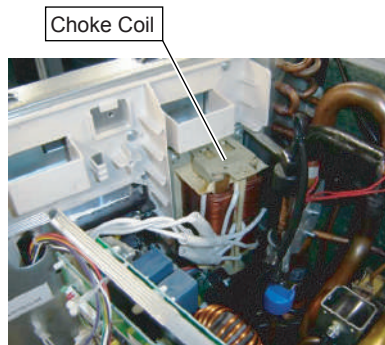

Choke Coil

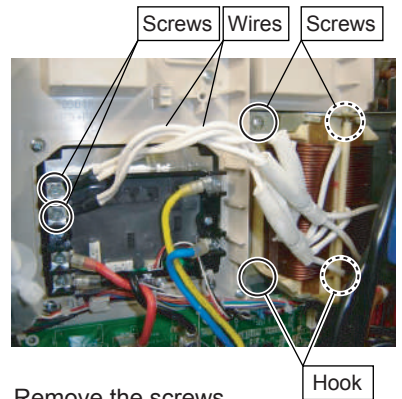

Remove the screws.
Remove the wires.
Remove the mounting screws.
Remove the CHOKE COIL.

12. PIPE COVER FRONT removal

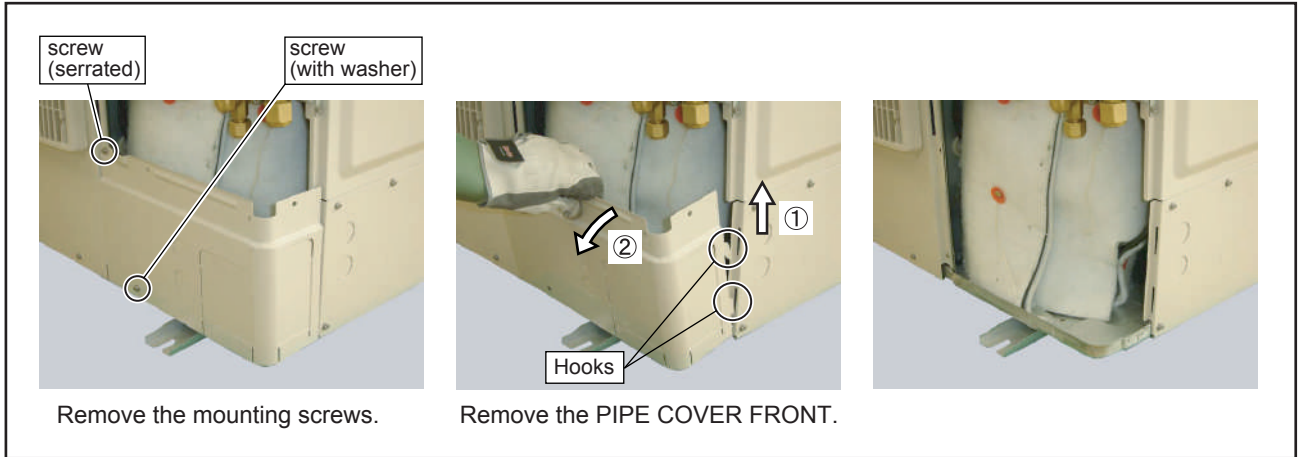

13. PIPE COVER REAR removal

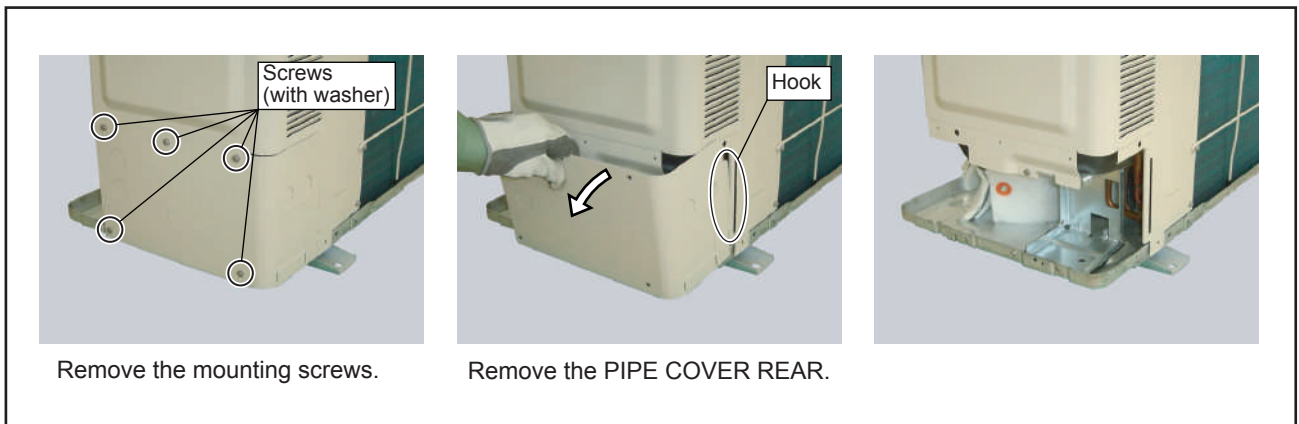

14. RIGHT PANEL removal

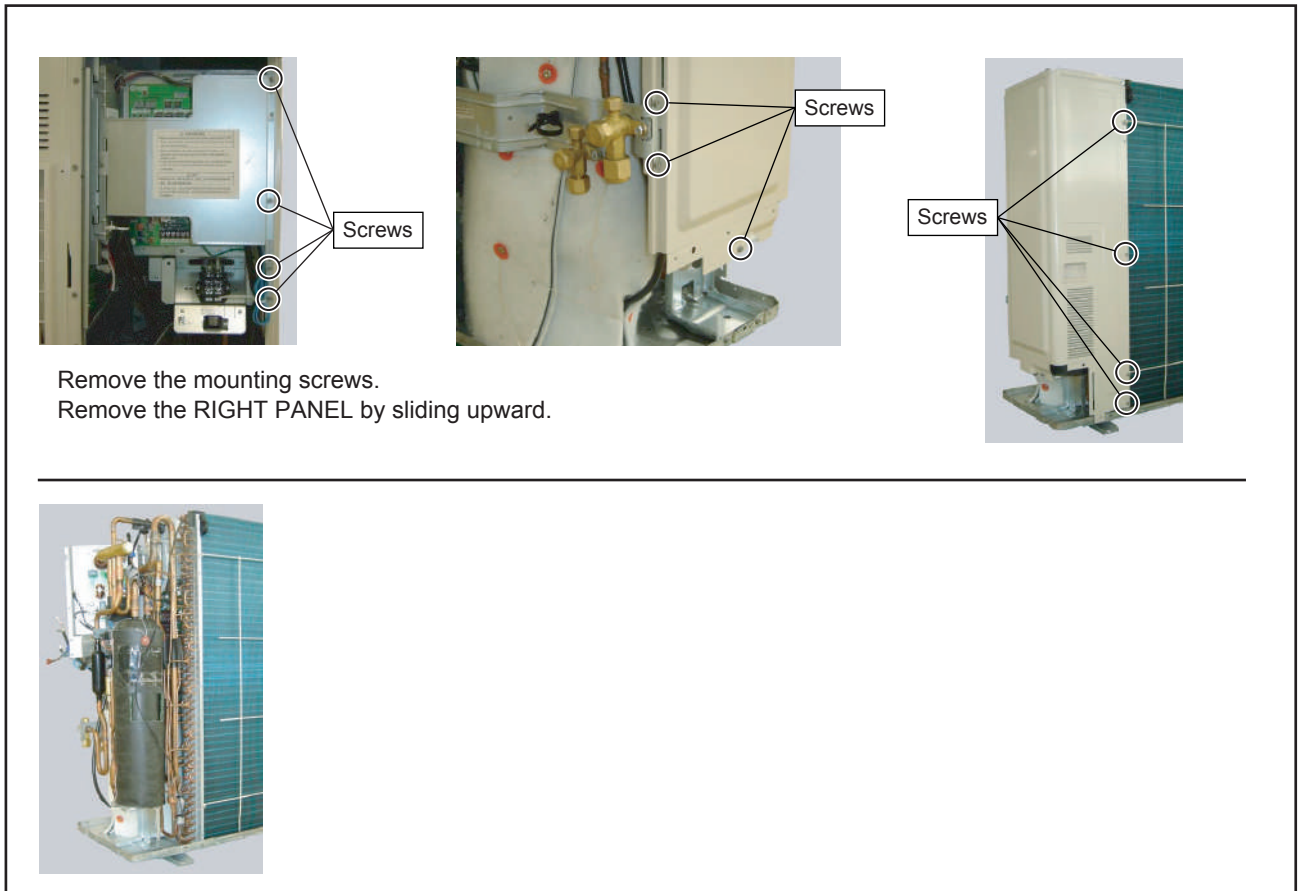

15. COMPRESSOR removal

Precautions for exchange of Compressor.

Do not allow moisture or debris to get inside refrigerant pipes during work.

Procedure for compressor removal.

- (1) Turn off power.
- (2) Remove the SERVICE PANEL and PIPE COVER FRONT.
- (3) Fully open the 3WAY VALVE(Gas) and 3WAY VALVE(Liquid).
- (4) Open the EEVs of Outdoor units and Indoor units by vaccuming mode.
- (5) Collect the refrigerant from the 3WAY VALVE.

Start the following work after completely collecting the refrigerant.

Do not reuse the refrigerant that has been collected.

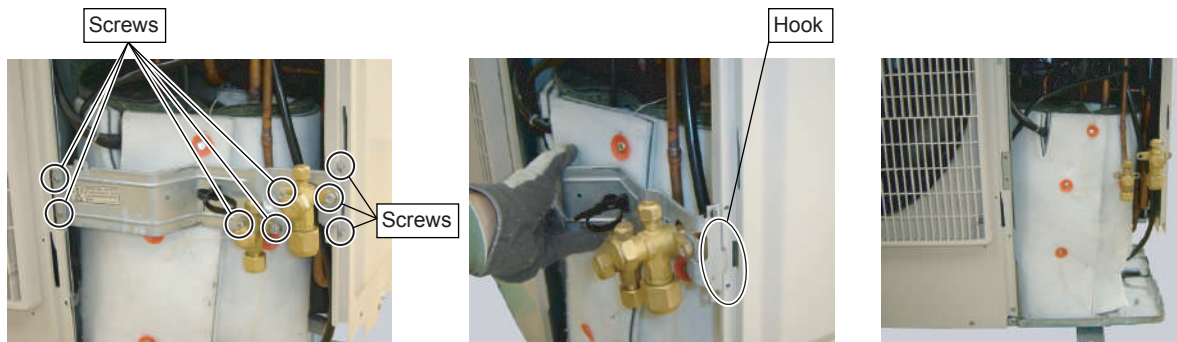

Remove the 8 mounting screws.

Remove the VALVE PLATE.

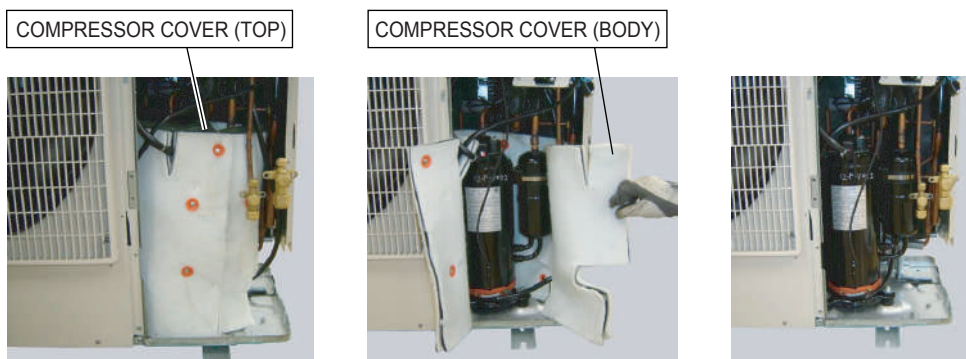

Remove the COMPRESSOR COVER BODY and TOP.

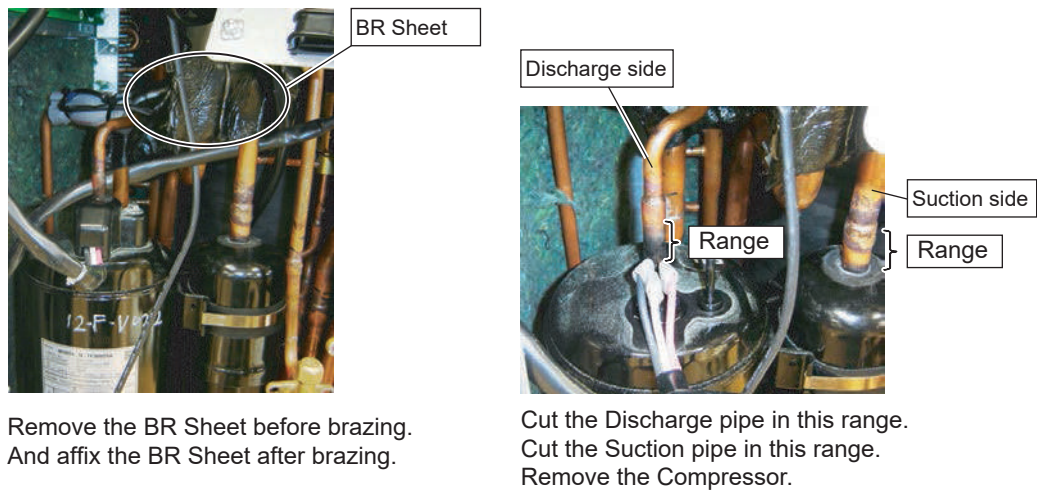
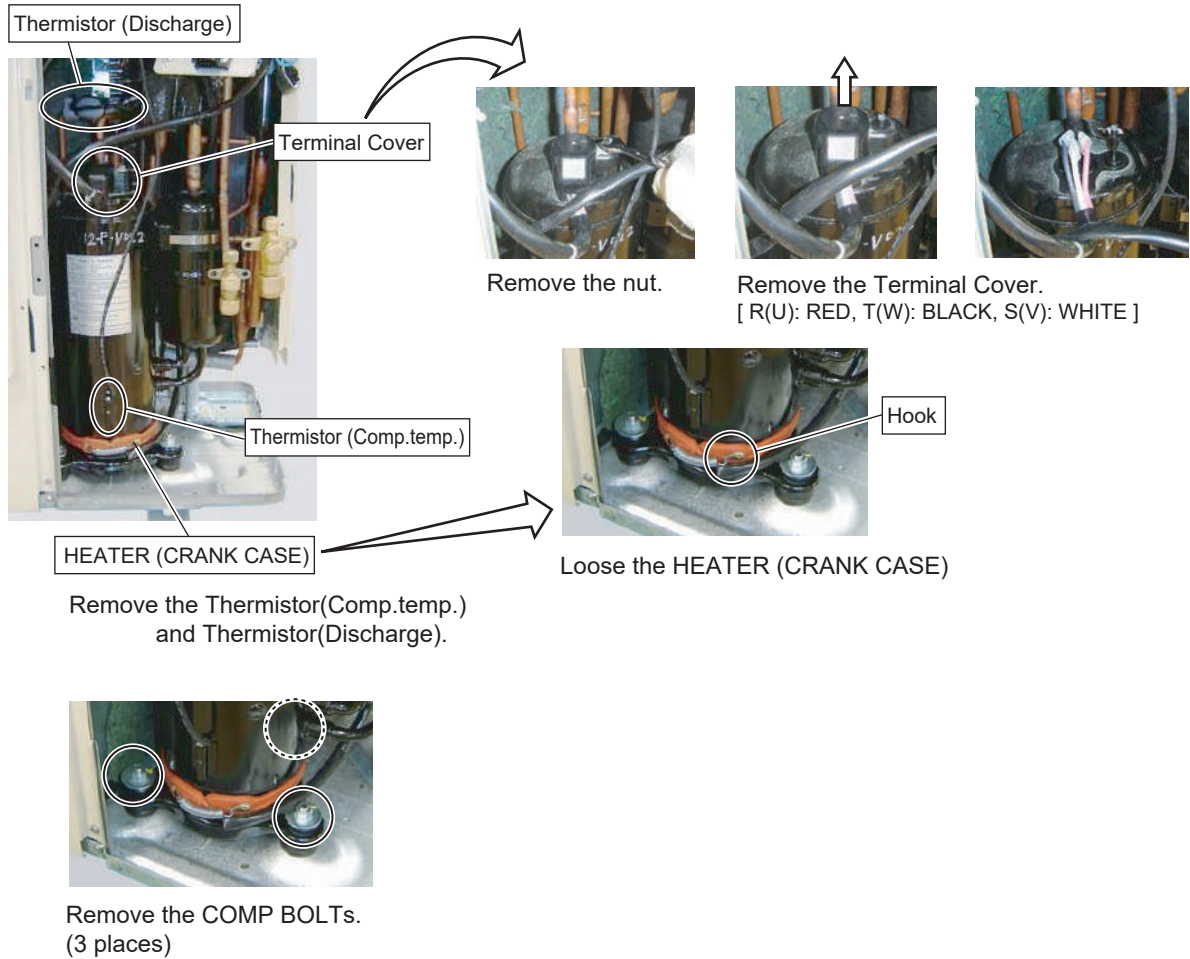

Caution

- Keep their shape better.
- There is a possibility of catching fire to oil when removing by the welding without cutting it.

Procedure for compressor installation.

Reverse procedure to removing the compressor.

Precautions for installation of Compressor.

- (1) When brazing, do not apply the flame to the terminal.
- (2) When brazing, be sure to replace the air in the pipe with nitrogen gas to prevent forming oxidization scale.

16. Precautions for exchange of refrigerant-cycle-parts

- (1) During exchange the following parts shall be protected by wet rag and not make the allowable temperature or more.
- (2) Remove the heat insulation when there is the heat insulation near the welding place.
Move and cool it when its detaching is difficult.
- (3) Cool the parts when there are parts where heat might be transmitted besides the replacement part.
- (4) Interrupt the flame with the fire-retardant board when the flame seems to hit the following parts directly.
- (5) Do not allow moisture or debris to get inside refrigerant pipes during work.
- (6) When brazing, be sure to replace the air in the pipe with nitrogen gas to prevent forming oxidization scale.
- (7) Open the 3WAY VALVE because there is a possibility of squirting the refrigerant from the heated pipes at brazing.

Part name	Allowable temperature	Precautions in work
SOLENOID VALVE	120°C	Remove the coil before brazing. And install the coil after brazing.
EXPANSION VALVE	120°C	Remove the coil before brazing. And install the coil after brazing.
4WAY VALVE	120°C	Remove the coil before brazing. And install the coil after brazing.
3WAY VALVE (GAS)	100°C	
3WAY VALVE (LIQUID)		
PRESSURE SENSOR	100°C	



FUJITSU GENERAL LIMITED

1116, Suenaga, Takatsu-ku, Kawasaki 213-8502, Japan

Product specifications are subject to change without notice.

"**AIRSTAGE**" is a worldwide trademark of FUJITSU GENERAL LIMITED.

Copyright © 2004 Fujitsu General Limited. All rights reserved.