

AIR CONDITIONER

2-unit multi-split type

SERVICE MANUAL



OUTDOOR



AOYG14KBTA2



AOYG18KBTA2

2-6. Outdoor unit

■ Model: AOYG14KBTA2

Unit: mm

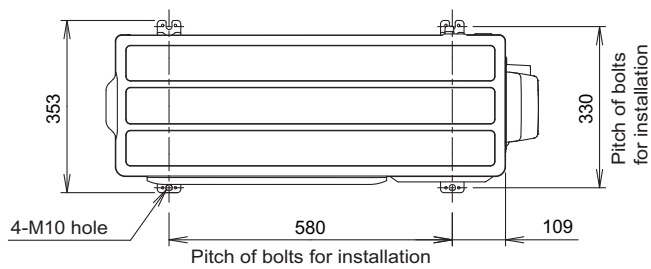

Top view

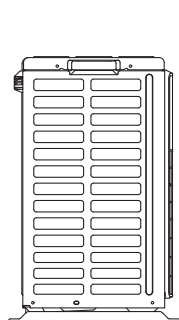

Side view

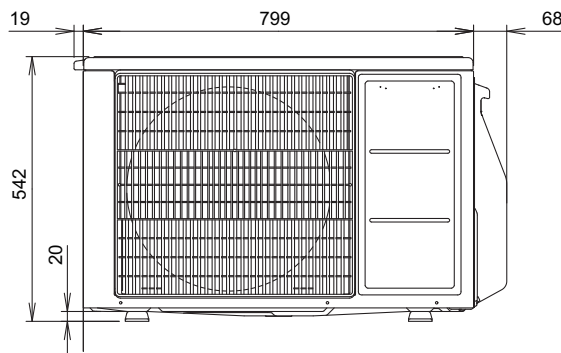

Front view

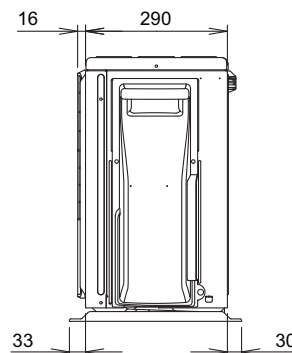

Side view

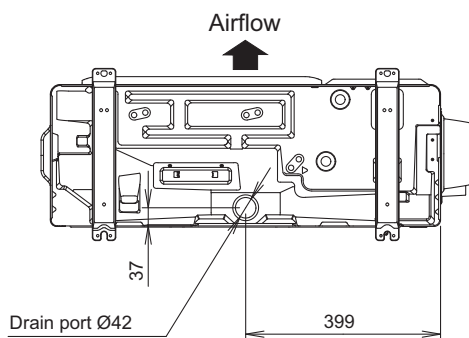

Bottom view

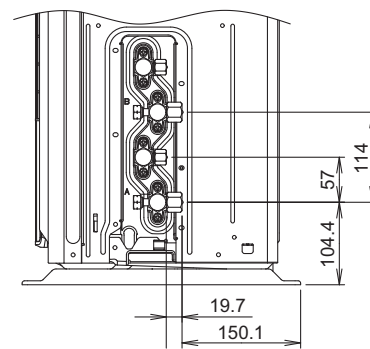

Side view (Valve part)

■ Model: AOYG18KBT A2

Unit: mm

GENERAL INFORMATION

GENERAL INFORMATION

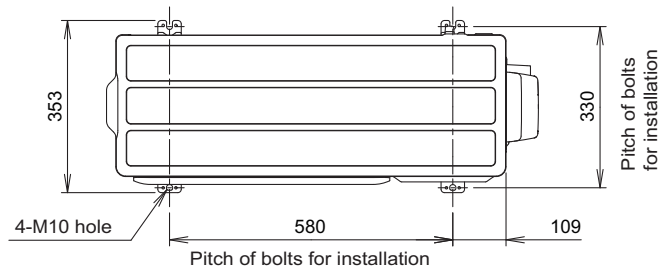

Top view

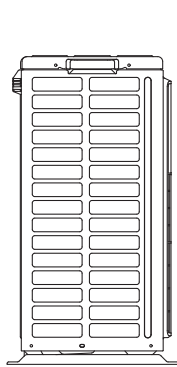

Side view

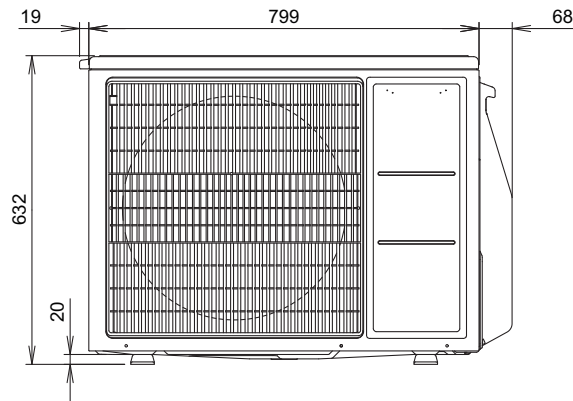

Front view

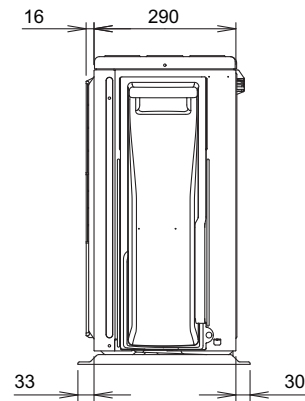

Side view

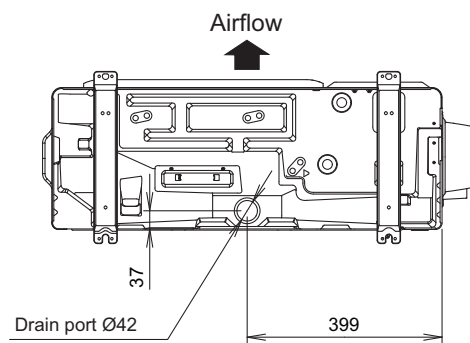

Bottom view

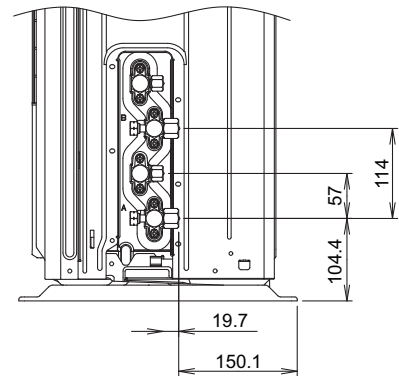

Side view (Valve part)

4. Outdoor unit parts list

4-1. Model: AOYG14KBTA2

■ Exterior parts and Chassis

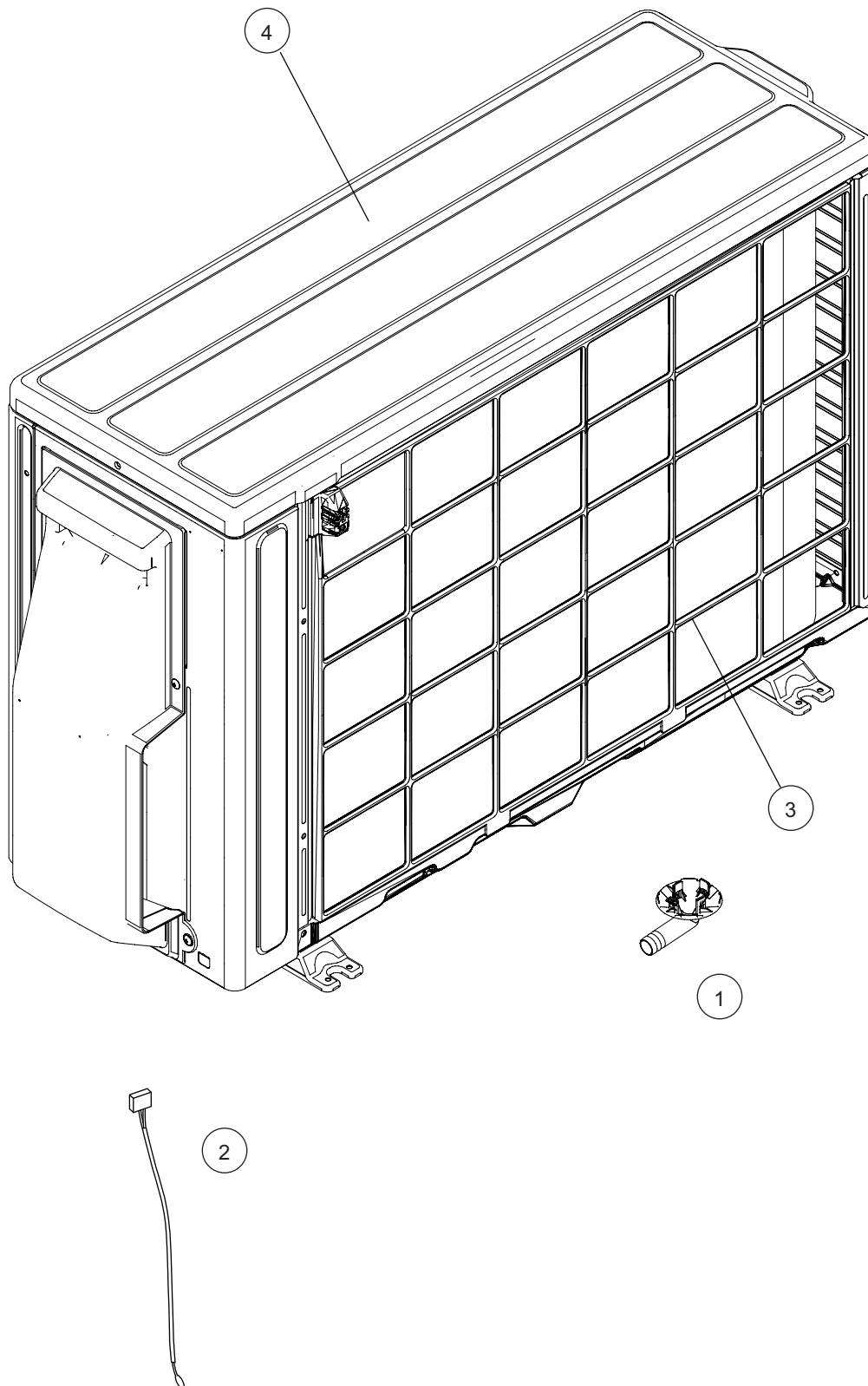

Item no.	Part no.	Part name	Service part
1	9322144003	Drain pipe	◆
2	9900565060	Outdoor thermistor	◆
3	9322811011	Protective net assy	◆
4	9322556028	Top panel assy	◆

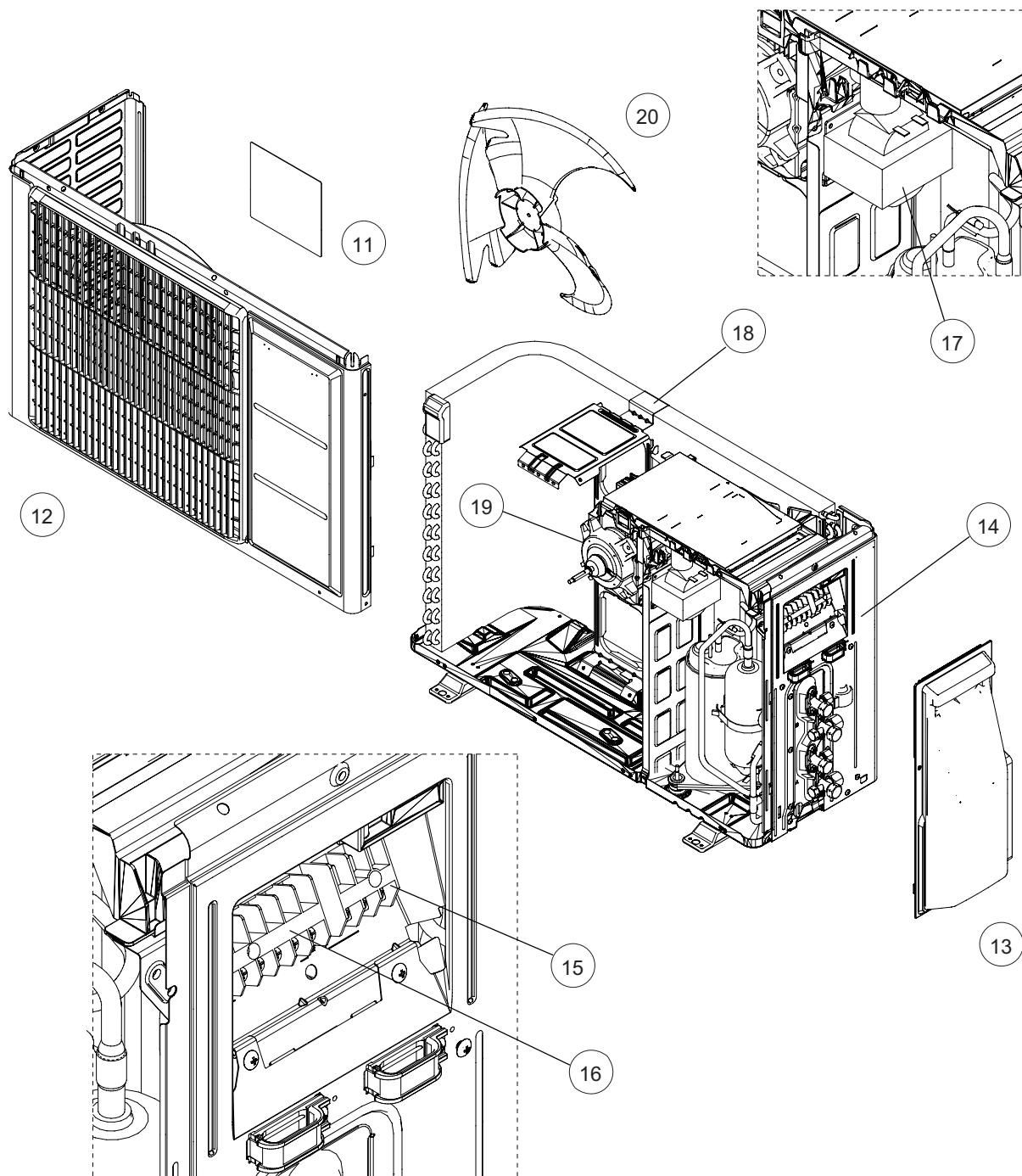

Item no.	Part no.	Part name	Service part
11	9319151007	Emblem	◆
12	9322555014	Front panel assy	◆
13	9322570055	Switch cover assy	◆
14	9322552181	Cabinet right assy	◆
15	9900369064	Terminal 3P	◆
16	9900435042	Terminal 6P	◆
17	9900963019	Reactor assy	◆
18	9322553010	Motor bracket assy	◆
19	9603553005	Brushless motor	◆
20	9322136008	Propeller fan	◆

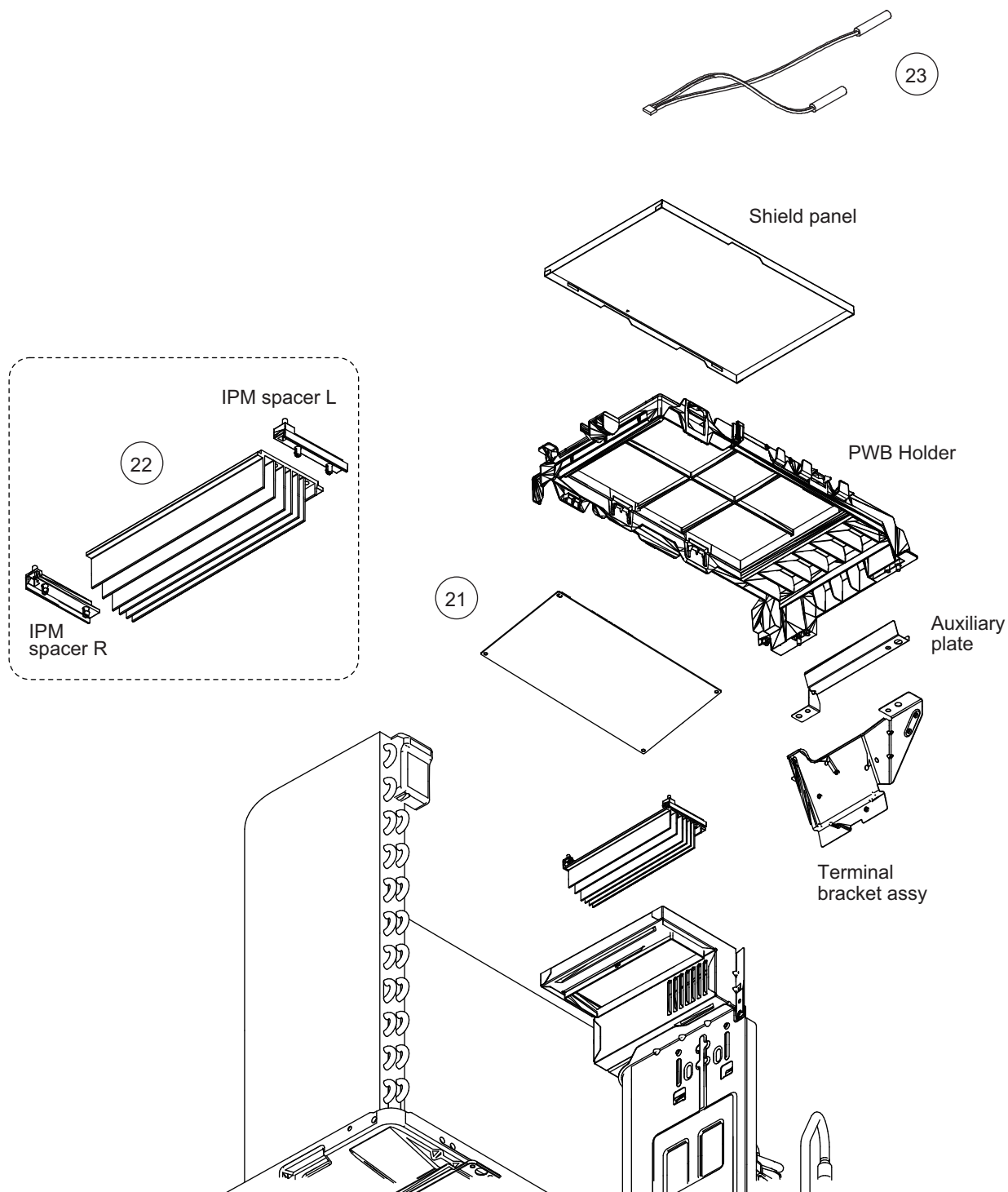

Item no.	Part no.	Part name	Service part
21	9709683781	Main PCB (Service unit)	◆
22	9322418005	Heat sink	◆
23	9900727062	Thermistor assy	◆
—	9900984014	Thermistor (Heat exchanger)	◆
—	9901025013	Thermistor assy (AB)	◆
—	9900985035	Compressor temp. thermistor	◆

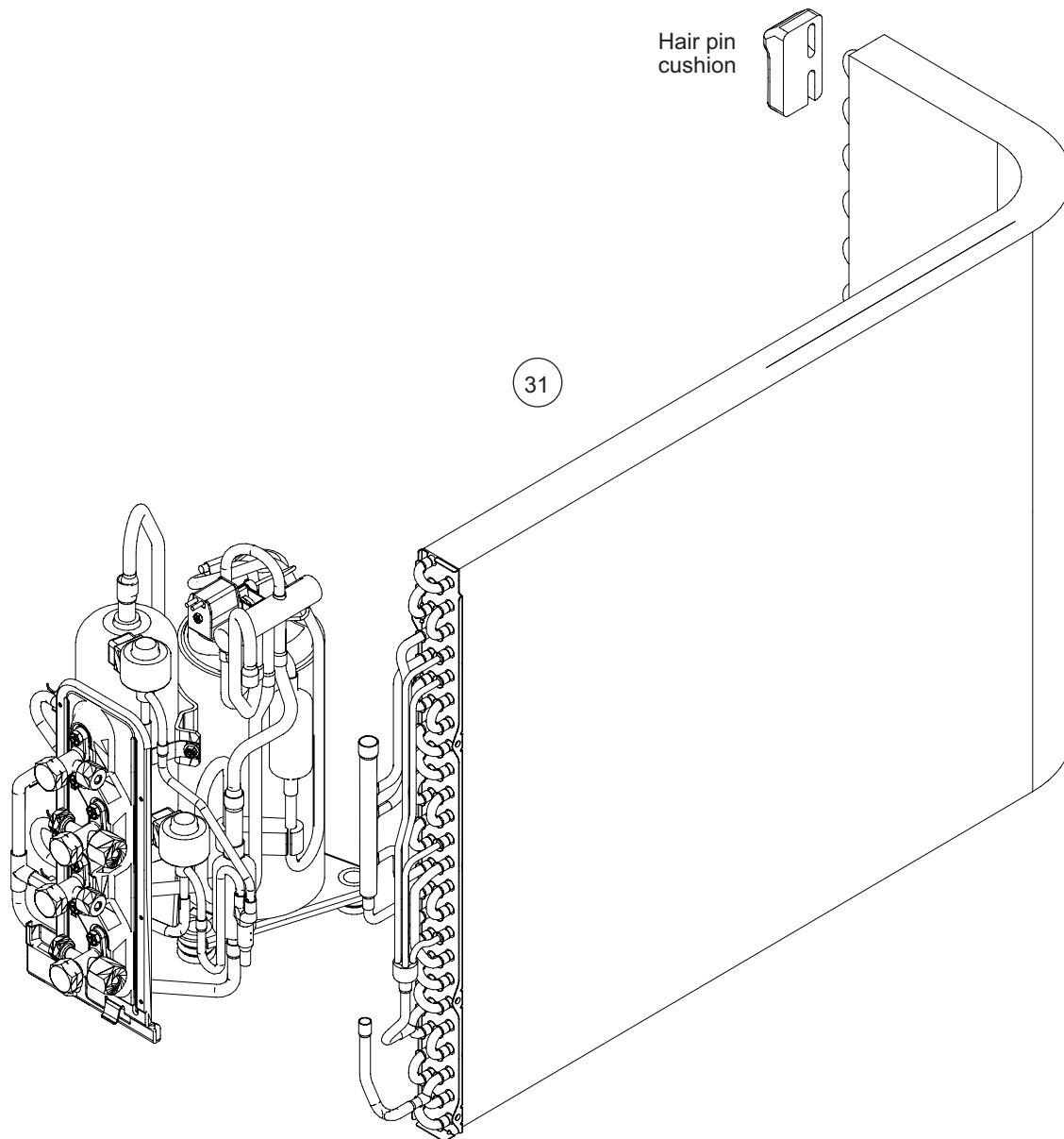

Item no.	Part no.	Part name	Service part
31	9323834576	Heat exchanger unit	◆
—	9322535009	S-insulator B	◆
—	9322536013	S-insulator F	◆
—	9322537003	S-insulator H	◆
—	9323045002	S-insulator V	◆

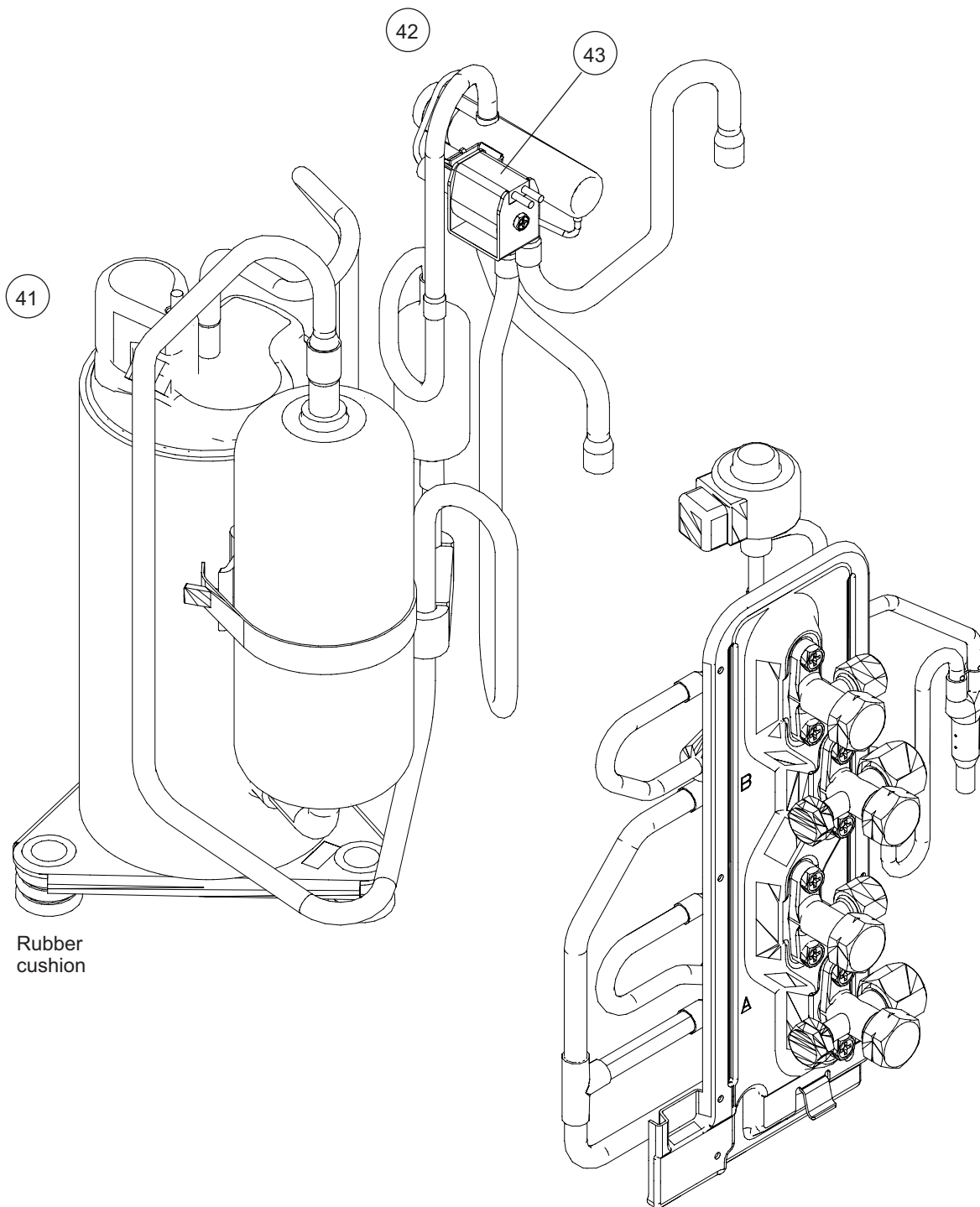

Rubber
cushion

Item no.	Part no.	Part name	Service part
41	9322427021	Compressor assy	◆
42	9322444035	4-way valve assy	◆
43	9970206009	Solenoid	◆

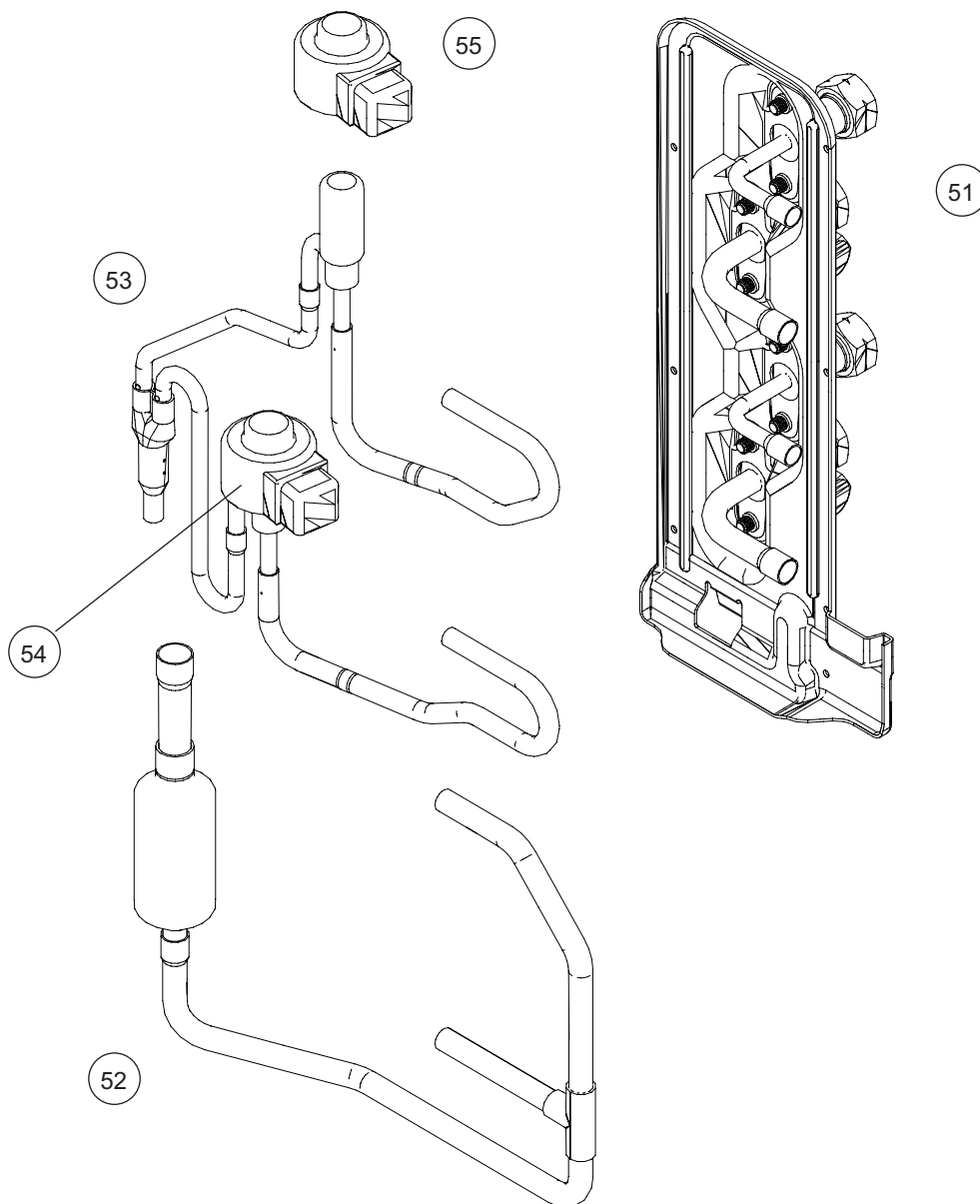

Item no.	Part no.	Part name	Service part
51	9383070006	Valve assy	◆
52	9382236038	Valve gas pipe assy	◆
53	9383071003	Pulse motor valve assy	◆
54	9970186042	Expansion valve coil (A)	◆
55	9970187032	Expansion valve coil (B)	◆

4-2. Model: AOYG18KBTA2

■ Exterior parts and Chassis

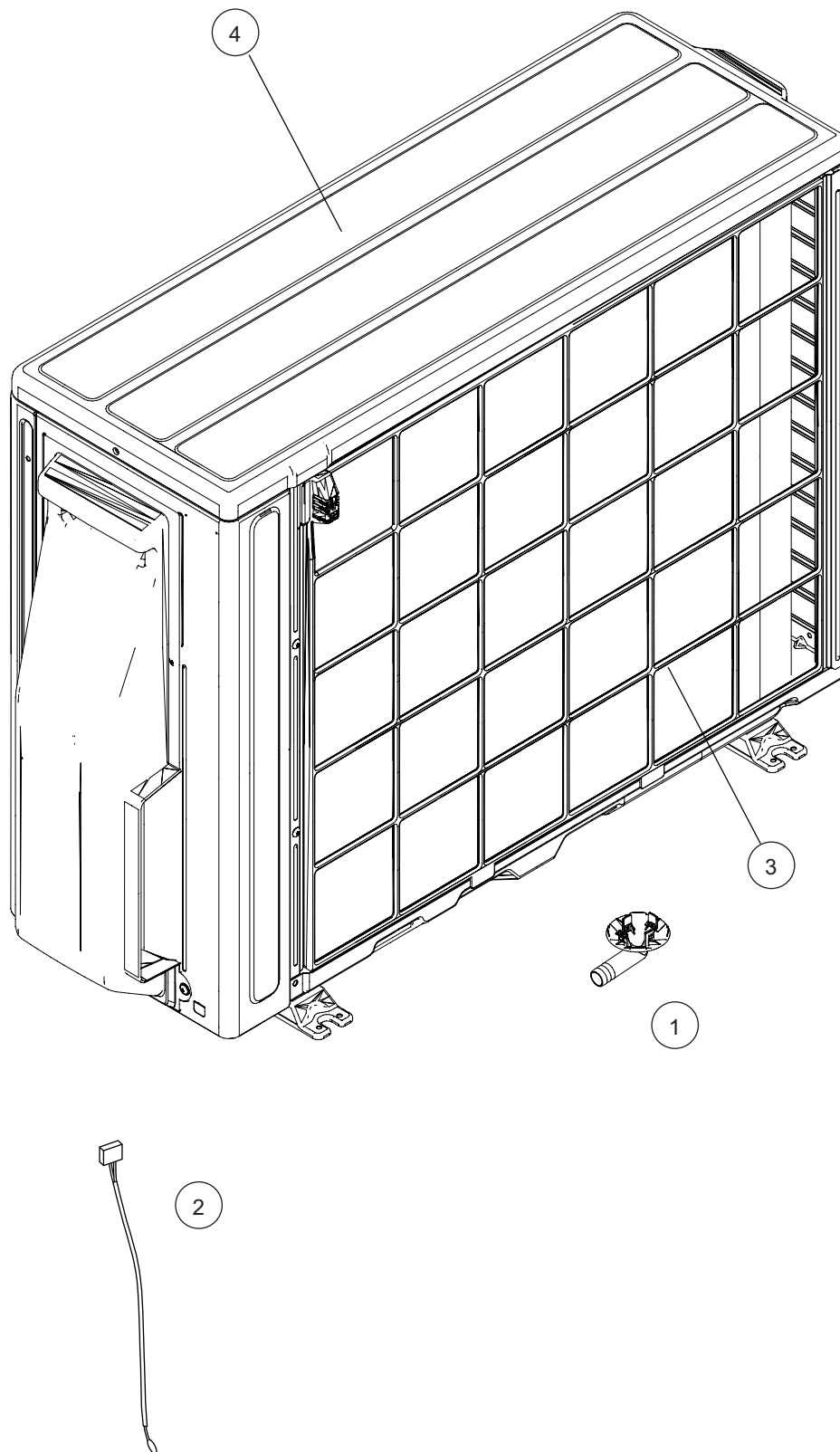

Item no.	Part no.	Part name	Service part
1	9322144003	Drain pipe	◆
2	9900565060	Outdoor thermistor	◆
3	9322811028	Protective net assy	◆
4	9322556028	Top panel assy	◆

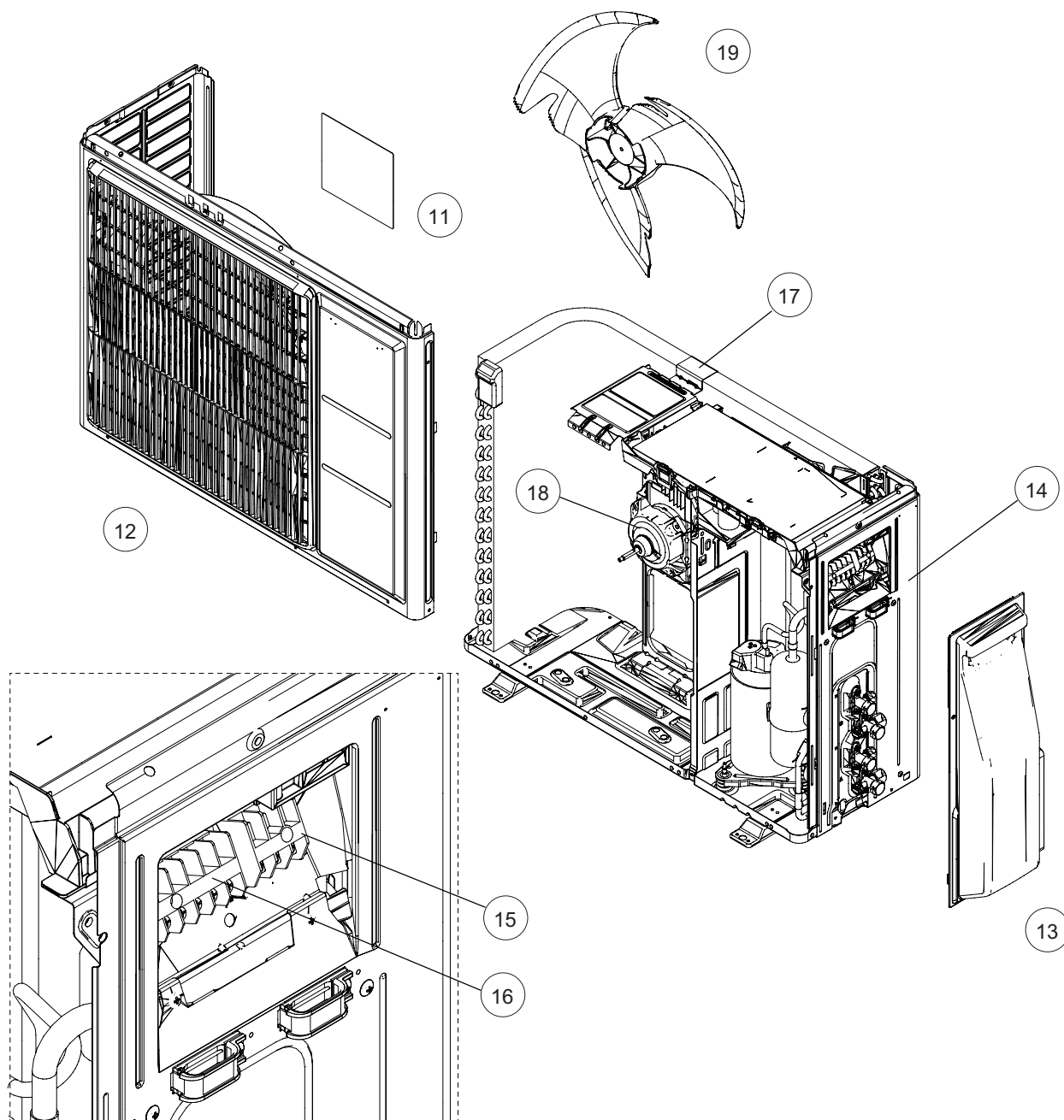

Item no.	Part no.	Part name	Service part
11	9319151007	Emblem	◆
12	9322555021	Front panel assy	◆
13	9322570062	Switch cover assy	◆
14	9322552198	Cabinet right assy	◆
15	9900369064	Terminal 3P	◆
16	9900435042	Terminal 6P	◆
17	9322553027	Motor bracket assy	◆
18	9603601003	Brushless motor	◆
19	9322150004	Propeller fan	◆

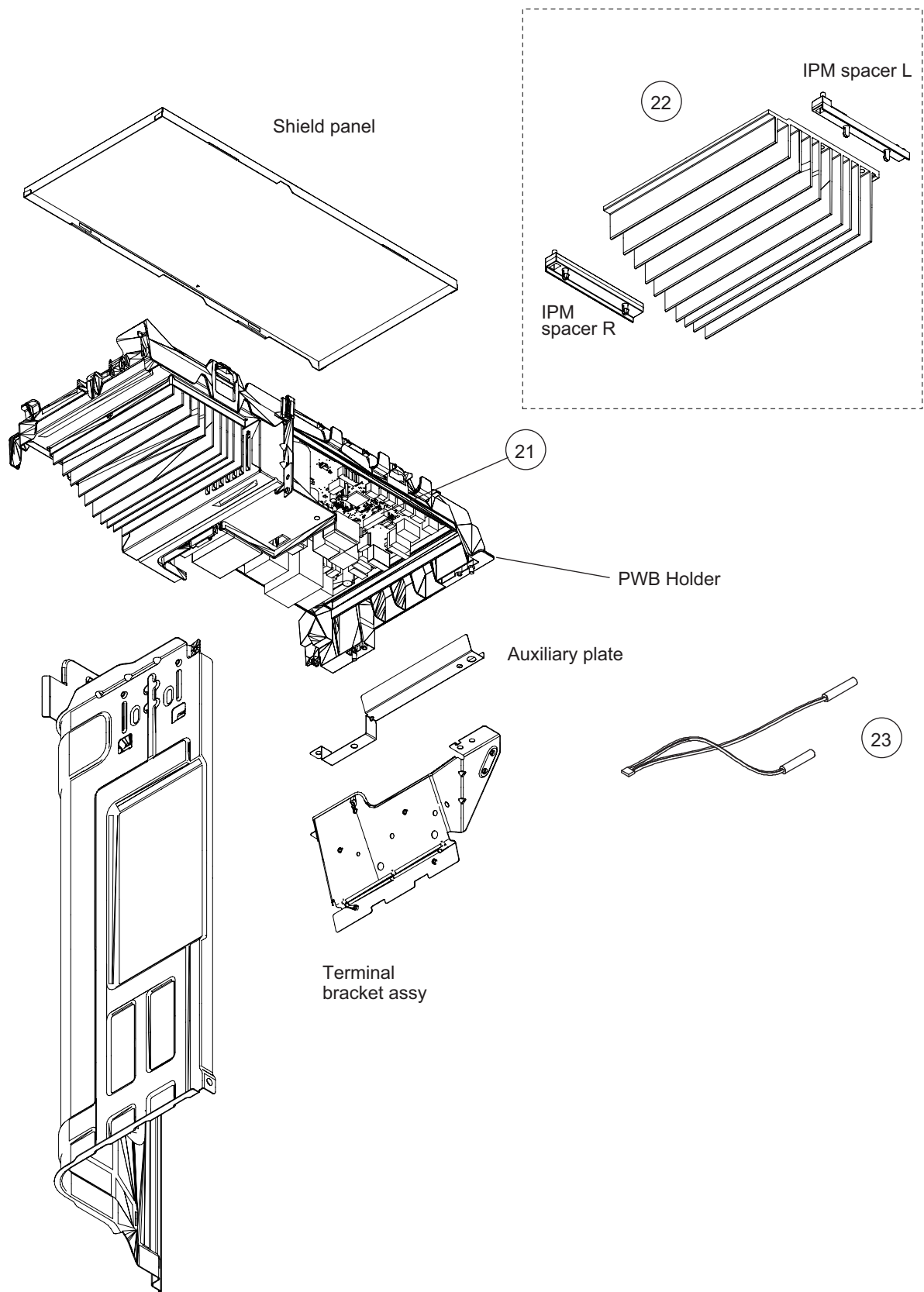

Item no.	Part no.	Part name	Service part
21	9709683774	Main PCB (Service unit)	◆
22	9322420039	Heat sink	◆
23	9900727079	Thermistor assy	◆
—	9900984014	Thermistor (Heat exchanger)	◆
—	9901025013	Thermistor assy (AB)	◆
—	9900985035	Compressor temp. thermistor	◆

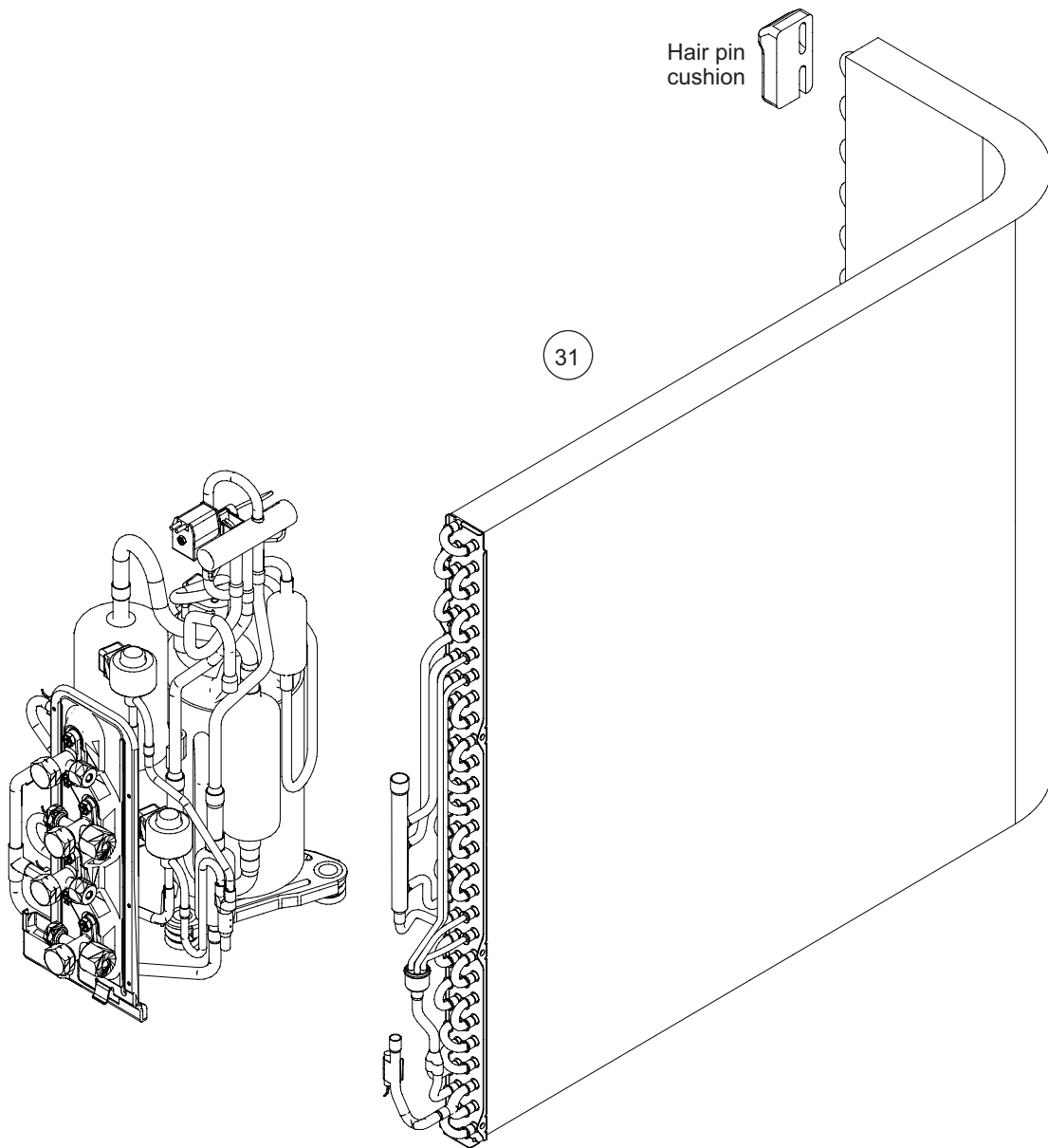

Item no.	Part no.	Part name	Service part
31	9323834583	Heat exchanger unit	◆
—	9322500007	S-insulator B	◆
—	9322847010	S-insulator F	◆
—	9322501004	S-insulator H	◆
—	9323045002	S-insulator V	◆

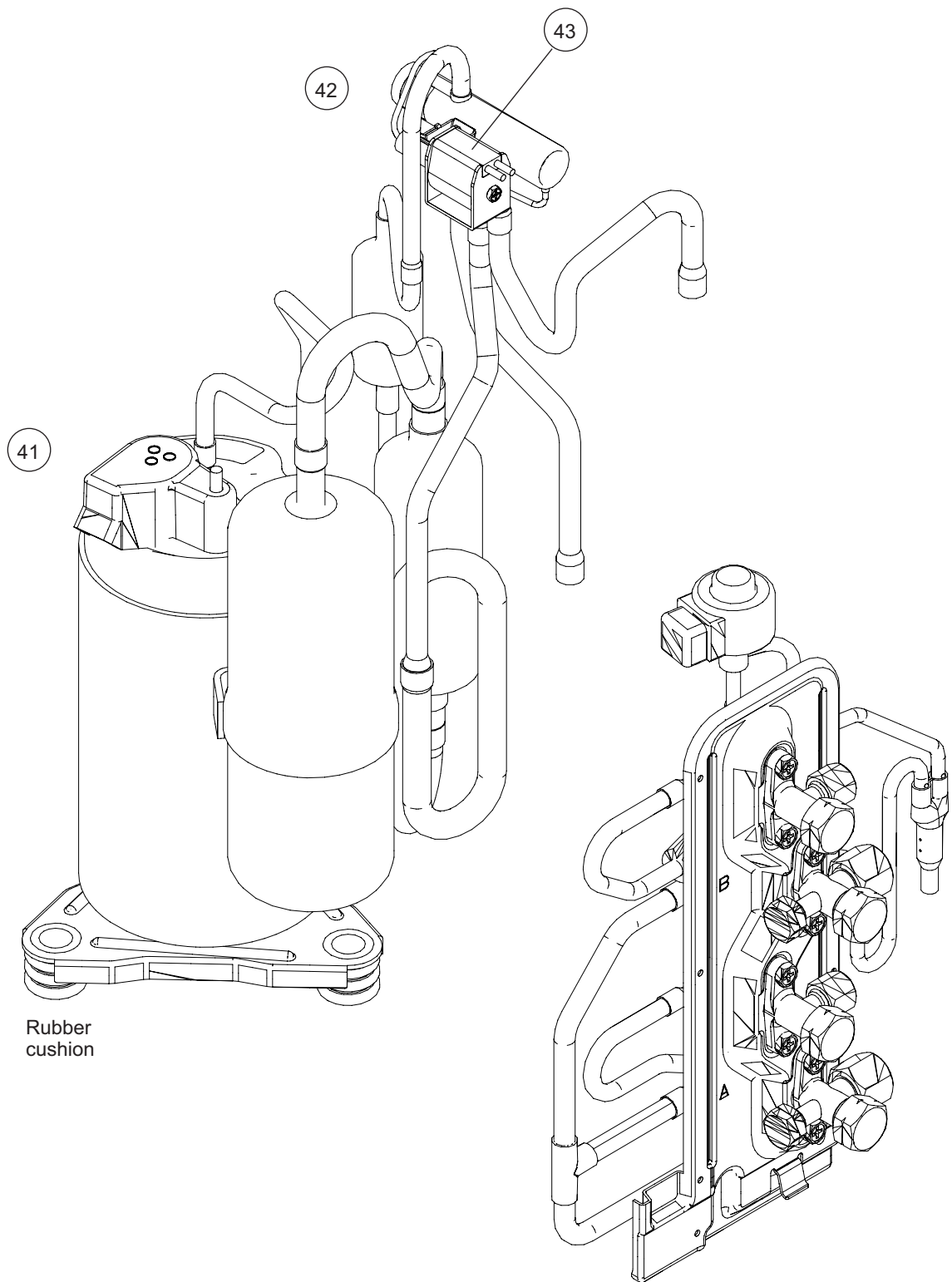

Rubber
cushion

Item no.	Part no.	Part name	Service part
41	9322433046	Compressor assy	◆
42	9322783011	4-way valve assy	◆
43	9970206009	Solenoid	◆

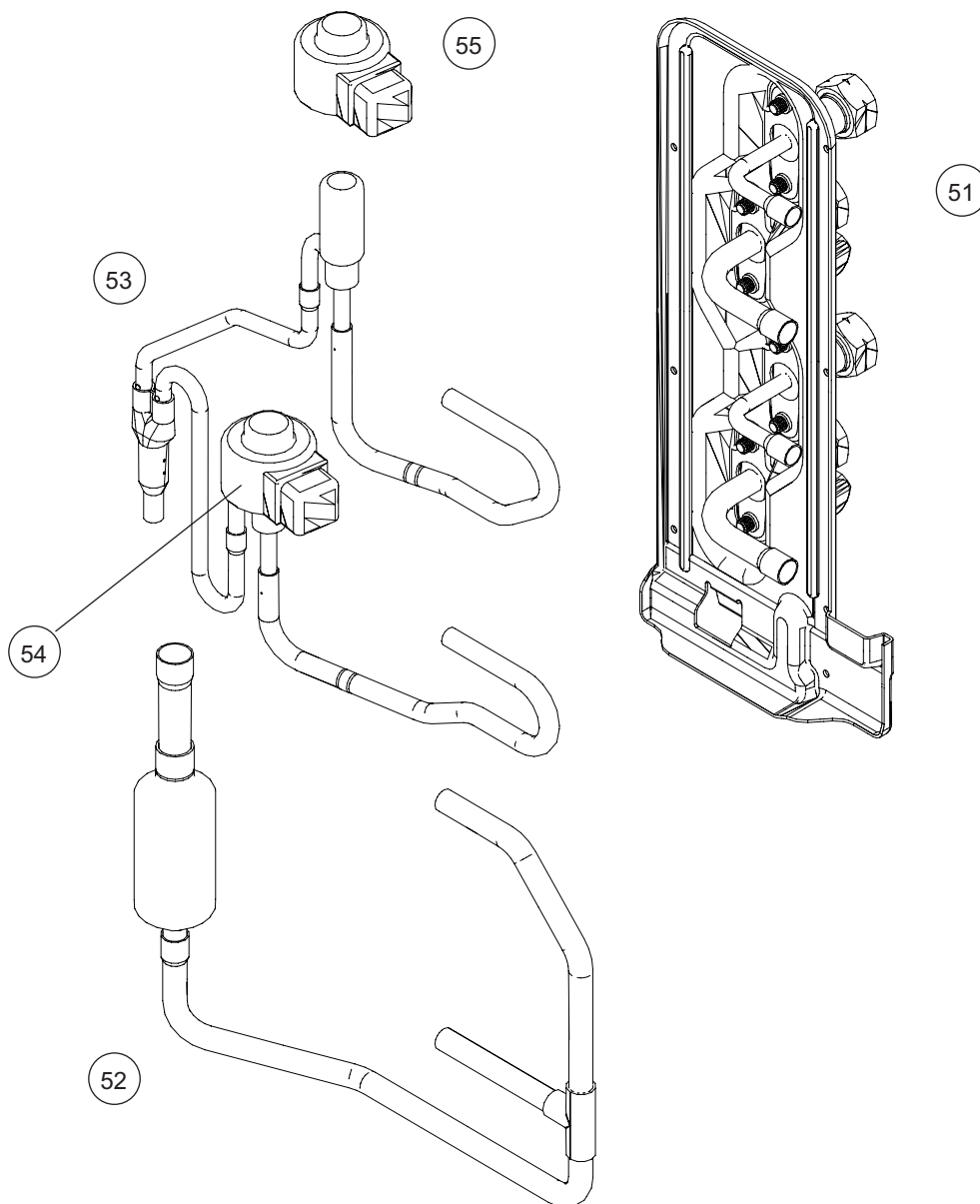

Item no.	Part no.	Part name	Service part
51	9383070006	Valve assy	◆
52	9382236038	Valve gas pipe assy	◆
53	9383071003	Pulse motor valve assy	◆
54	9970186042	Expansion valve coil (A)	◆
55	9970187032	Expansion valve coil (B)	◆