

SPLIT TYPE
AIR CONDITIONER
DUCT TYPE (50Hz)

SERVICE MANUAL



Indoor unit	Outdoor unit
ARYA30LBTU	AOYA30LFTL
ARYA36LBTU	AOYA36LFTL

CONTENTS

SPECIFICATIONS.....	1
DIMENSIONS.....	2
REFRIGERANT SYSTEM DIAGRAM.....	4
CIRCUIT DIAGRAM.....	5
INDOOR PCB CIRCUIT DIAGRAM.....	6
OUTDOOR PCB CIRCUIT DIAGRAM.....	9
ERROR DETECTION.....	14
PARTS (INDOOR UNIT).....	16
PARTS (OUTDOOR UNIT).....	19
ACCESSORIES.....	23

SPECIFICATIONS

ELECTRICAL DATA

TYPE		Cooling & Heating	
INDOOR UNIT		ARYA30LBTU	ARYA36LBTU
OUTDOOR UNIT		AOYA30LFTL	AOYA36LFTL
COOLING CAPACITY		8.5 kW	9.4 kW
HEATING CAPACITY		10.0 kW	11.2 kW
POWER SOURCE		230 V 50 Hz	230 V 50 Hz
RUNNING CURRENT	Cooling	11.6 A	12.8 A
	Heating	11.7 A	13.6 A
INPUT WATTS	Cooling	2.65 kW	2.93 kW
	Heating	2.68 kW	3.10 kW
E.E.R.	Cooling	3.21 kW/kW	3.21 kW/kW
	Heating	3.73 kW/kW	3.61 kW/kW
STARTING CURRENT		15 A	15 A
MOISTURE REMOVAL		2.5 L/hr	3.0 L/hr
AIRCIRCULATION INDOOR	Cooling	1,950 m3/hr	1,950 m3/hr
	Heating	2,100 m3/hr	2,100 m3/hr
AIRCIRCULATION OUTDOOR		3,600 m3/hr	3,800 m3/hr
MAXIMUM CURRENT		17.0 A	20.0 A

FAN SPEED

INDOOR UNIT	Discrimination	MFG-45RVN	MFG-45RVN
	High (cooling)	1,170 r.p.m.	1,170 r.p.m.
	High (heating)	1,270 r.p.m.	1,270 r.p.m.
	Med speed	980 r.p.m.	980 r.p.m.
	Low speed	790 r.p.m.	790 r.p.m.
	Quiet	630 r.p.m.	630 r.p.m.
OUTDOOR UNIT	Discrimination	MFE-60TVT	MFE-60TVT
	Speed	850 r.p.m.	900 r.p.m.

NOISE LEVEL

INDOOR UNIT	High speed	42 dB	42 dB
	Med speed	37 dB	37 dB
	Low speed	32 dB	32 dB
	Quiet	29 dB	29 dB
OUTDOOR UNIT	Cooling	53 dB	54 dB
	Heating	55 dB	55 dB

Note : Static pressure : 47Pa
Duct length : Inlet 1m, Outlet 2m

DIMENSIONS

INDOOR UNIT	H x W x D	270 x 1,135 x 700 mm
OUTDOOR UNIT	H x W x D	830 x 900 x 330 mm

WEIGHT

INDOOR UNIT	Shipping / Net	47 kg / 40 kg
OUTDOOR UNIT	Shipping / Net	68 kg / 61 kg

COMPRESSOR AND REFRIGERANT

COMPRESSOR TYPE	Hermetic type, Inverter, 6 poles, 3 phase, DC motor, Twin Rotary	
DISCRIMINATION	N-TF30ND1A	
WEIGHT (with oil)	15.5 kg	
PRECHARGED REFRIGERANT	2,100 g	
REFRIGERANT TYPE	R410A	
MAX PIPE LENGTH	50 m	
MAX PIPE HEIGHT	30 m	
FULL CHARGE	Pipe length 20 m	2,100 g
	30 m	2,500 g
	40 m	2,900 g
	50 m	3,300 g
ADDITIONAL CHARGE	40 g/m	

DIMENSIONS

INDOOR UNIT

(Unit : mm)

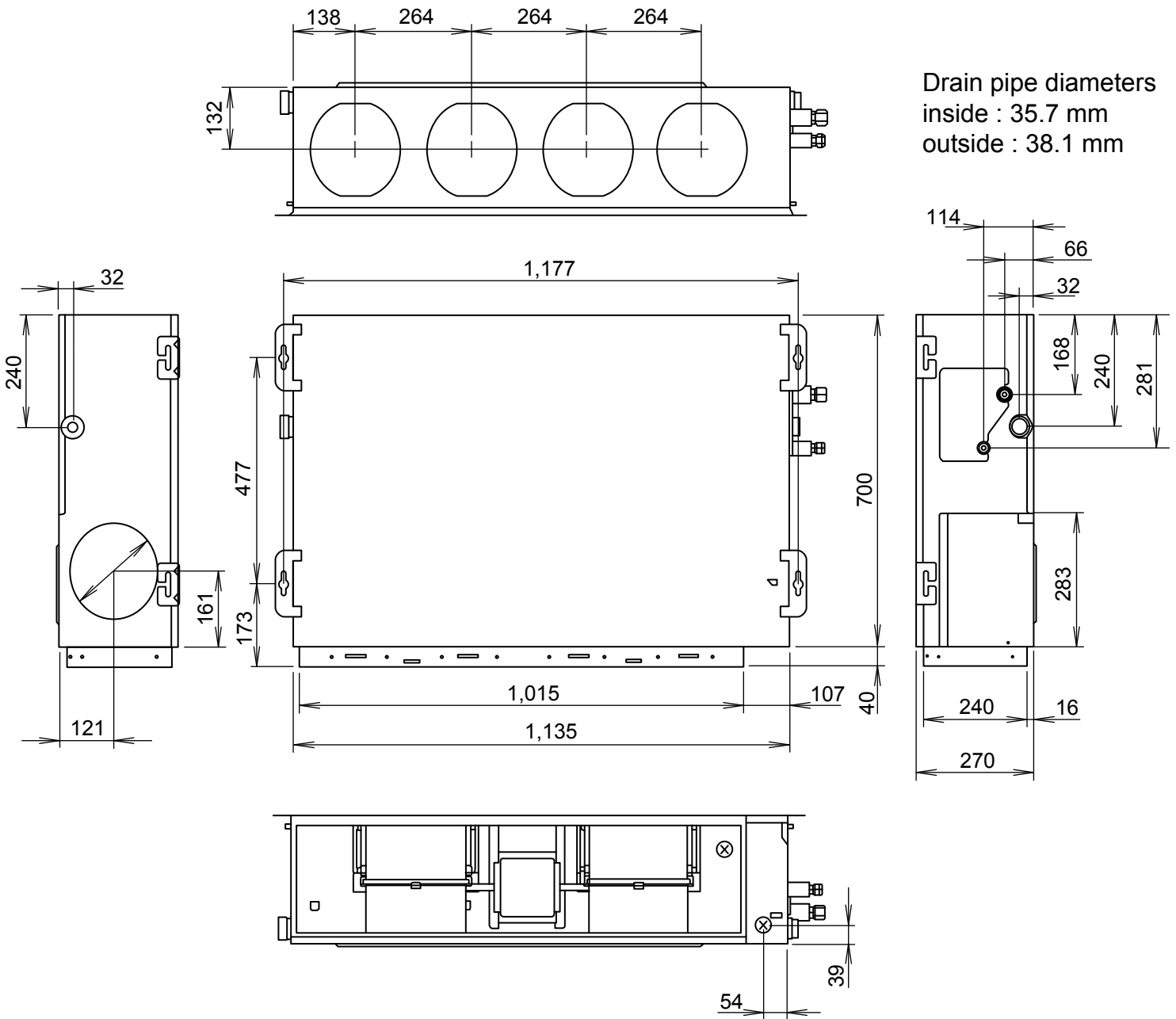

OUTDOOR UNIT

(Unit : mm)

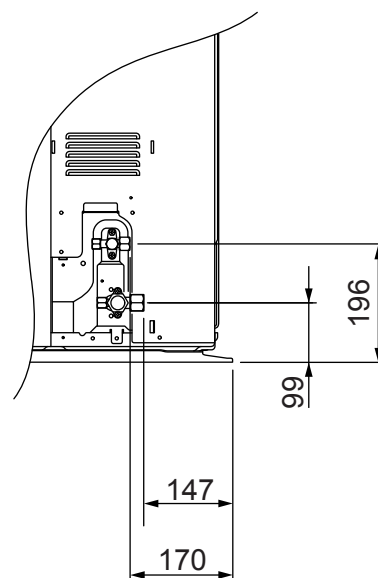
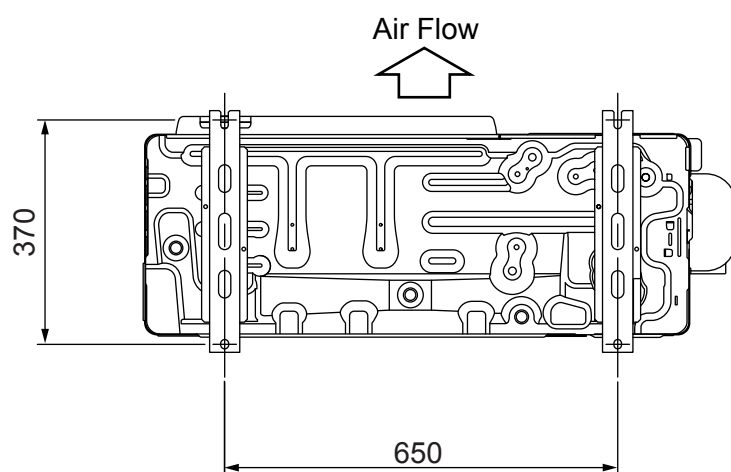
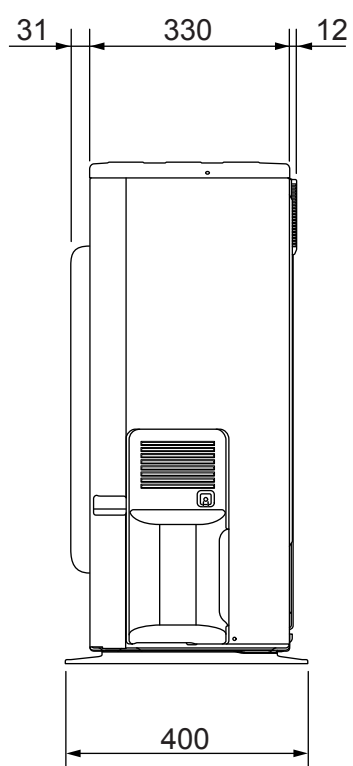
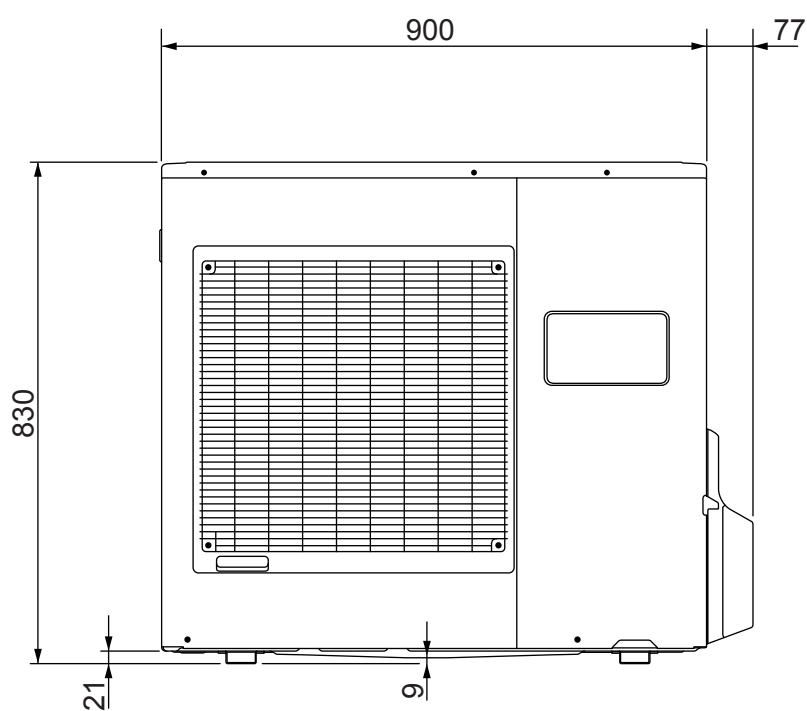
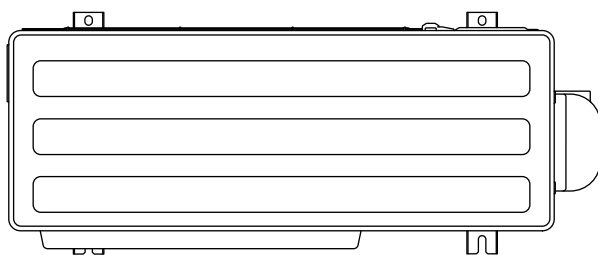

REFRIGERANT SYSTEM DIAGRAM

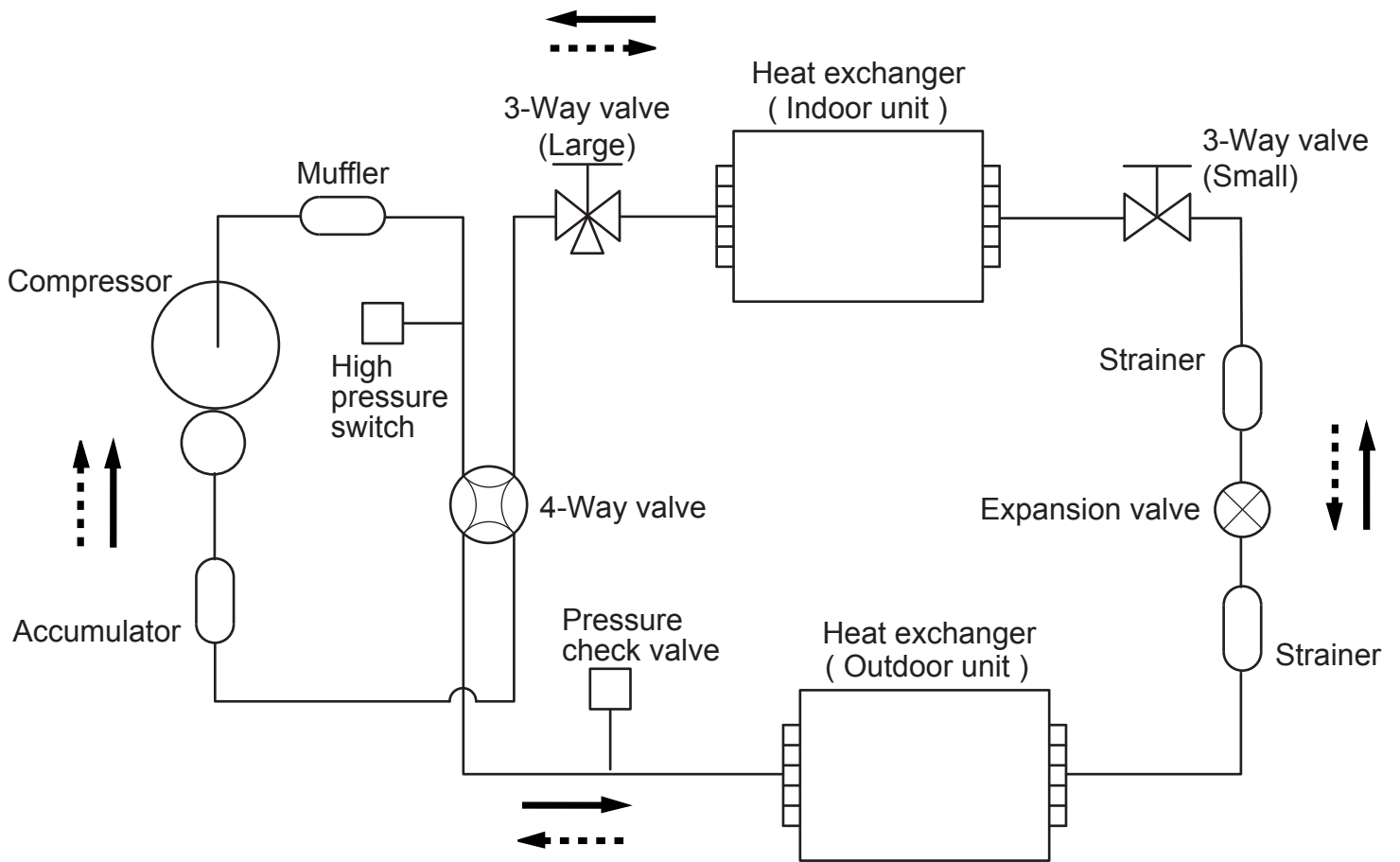

Refrigerant direction

—————▶ Cooling flow

.....▶ Heating flow

Refrigerant pipe diameter

Liquid : 3/8" (9.52 mm)

Gas : 5/8" (15.88 mm)

CIRCUIT DIAGRAM

INDOOR UNIT

OUTDOOR UNIT

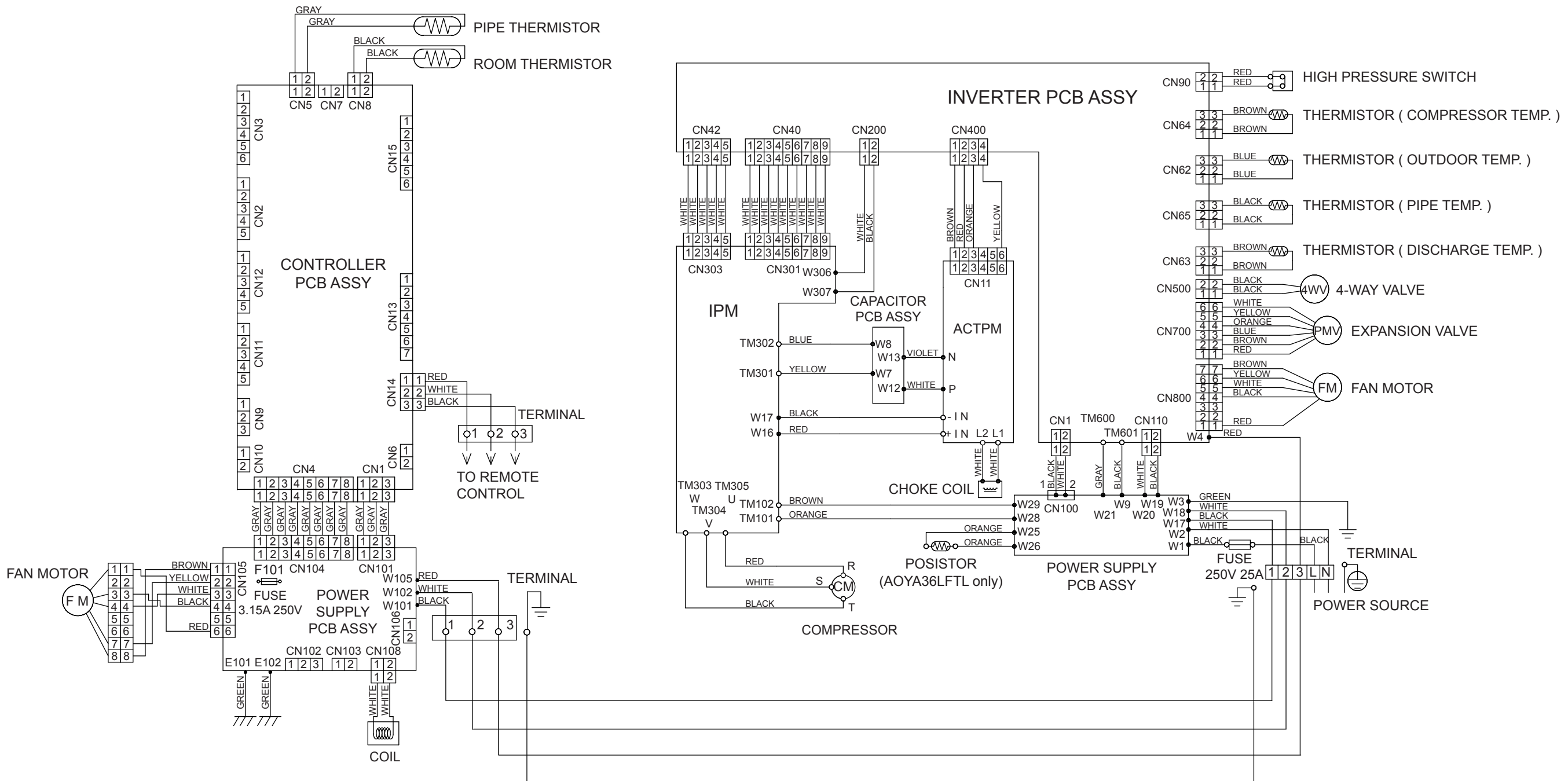

INDOOR UNIT
 CONTROLLER PCB ASSEMBLY
 ARYA30LBTU : K06AK-070AHSE-C1
 ARYA36LBTU : K06AK-070BHSE-C1

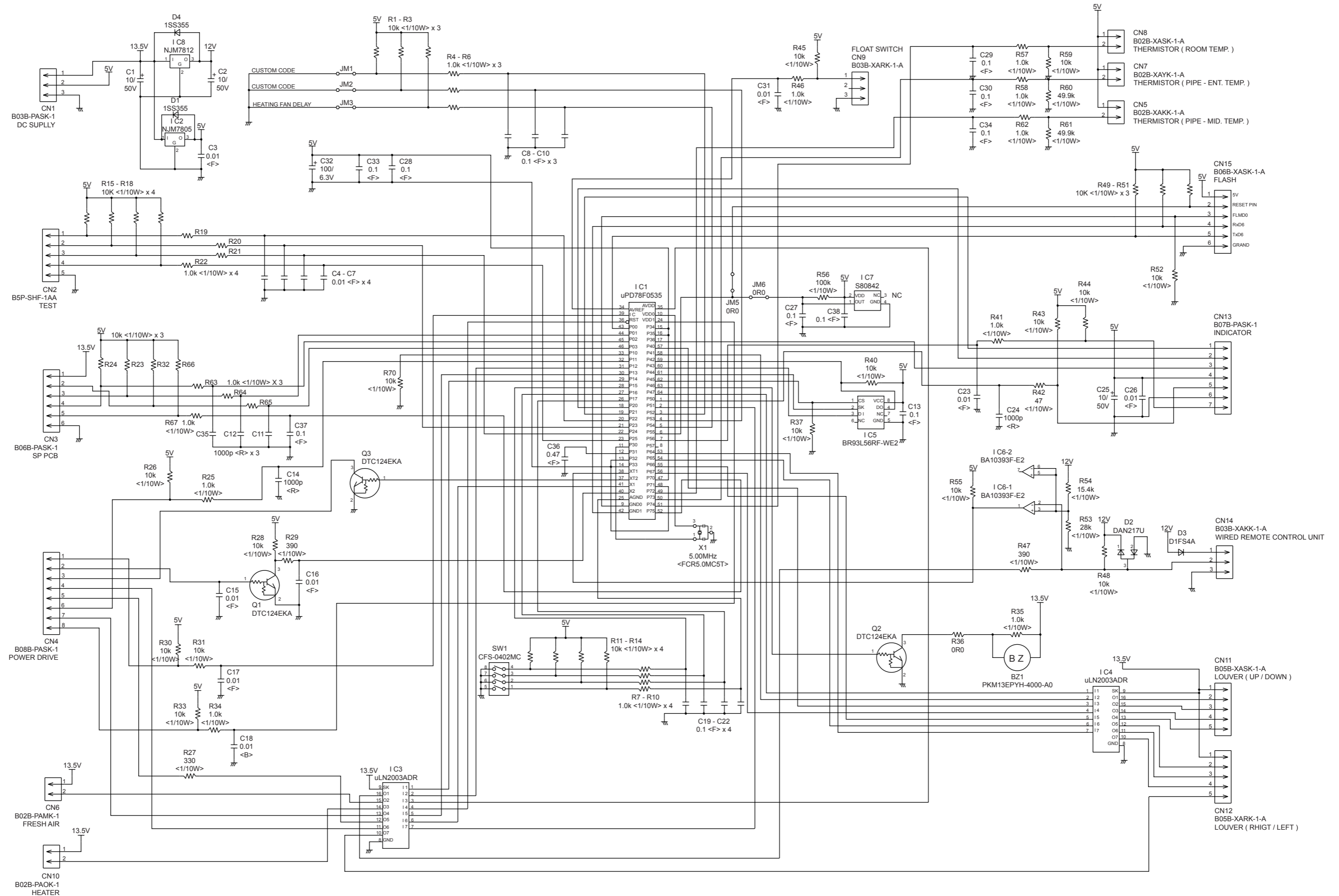

INDOOR UNIT
POWER SUPPLY PCB ASSEMBLY
K06AL-0605HSE-P0

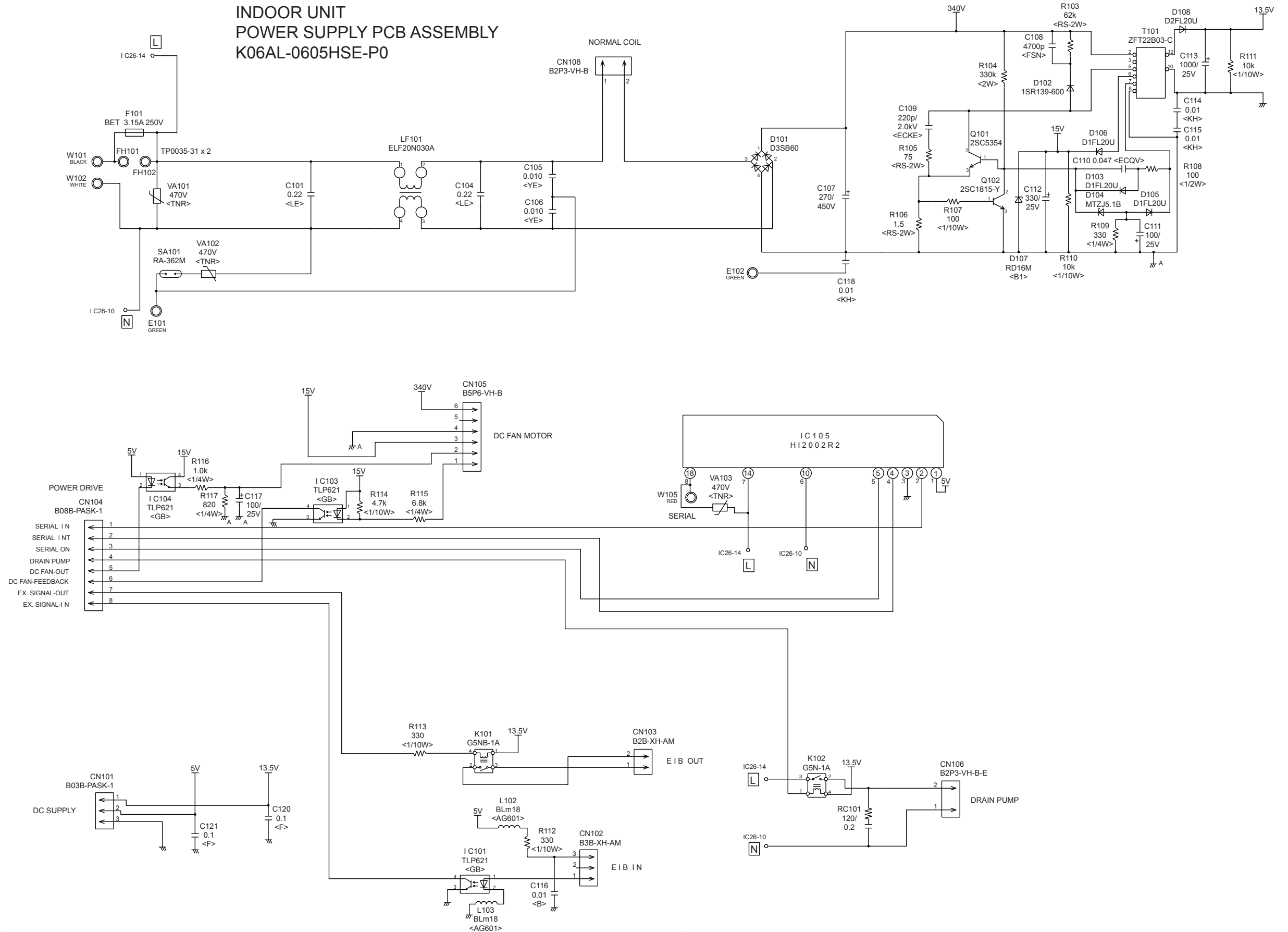

OUTDOOR PCB CIRCUIT DIAGRAM

INVERTER ASSEMBLY
 AOYA30LFTL : EZ-0099HUE
 AOYA36LFTL : EZ-009BHUE

TRANSISTOR PCB ASSEMBLY
 (I. P. M.)
 AOYA30LFTL : K07BT-0901HUE-TR0
 AOYA36LFTL : K07BT-0900HUE-TR0

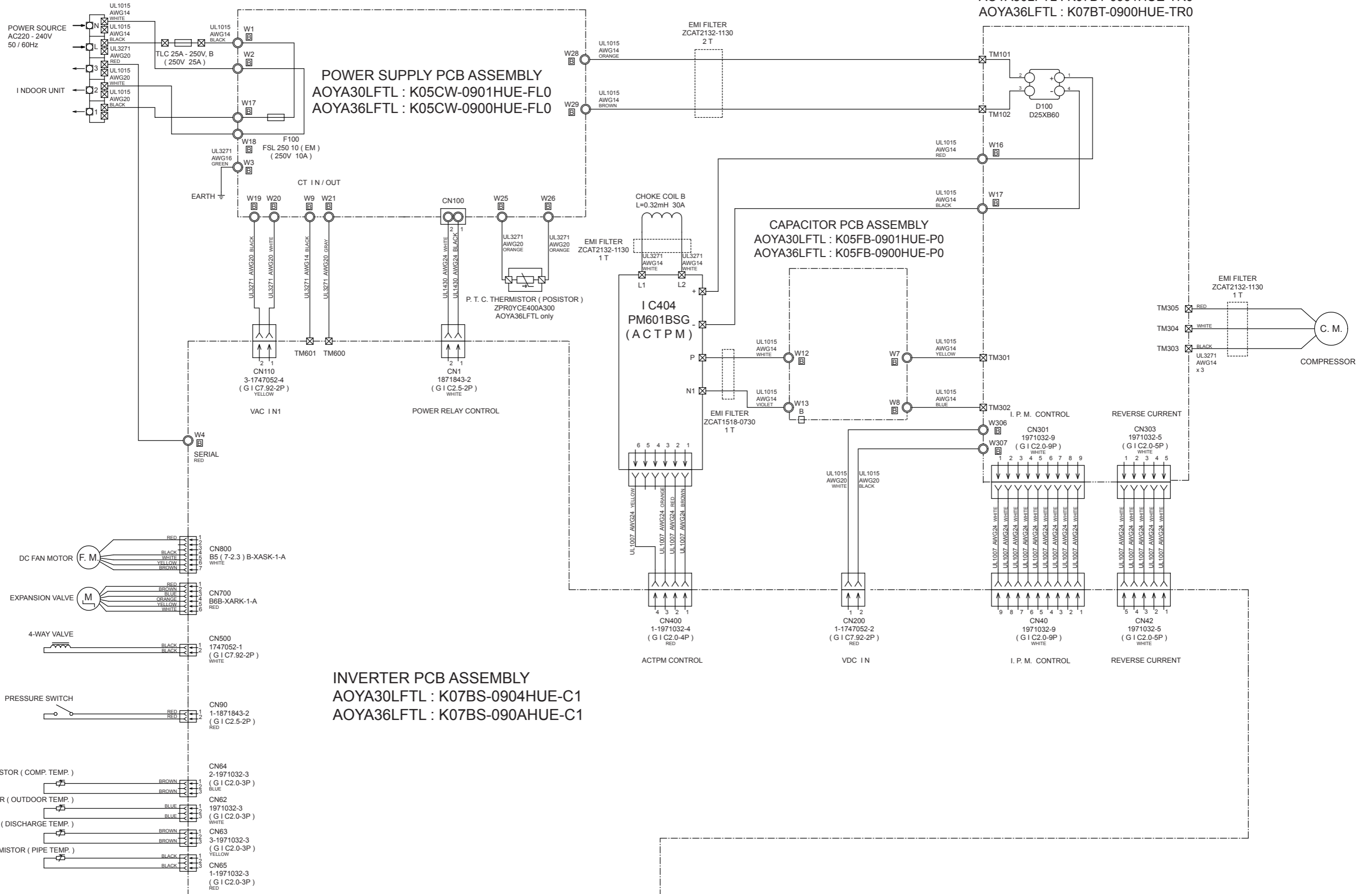

OUTDOOR UNIT
 INVERTER PCB ASSEMBLY
 AOYA30LFTL : K07BS-0904HUE-C1
 AOYA36LFTL : K07BS-090AHUE-C1

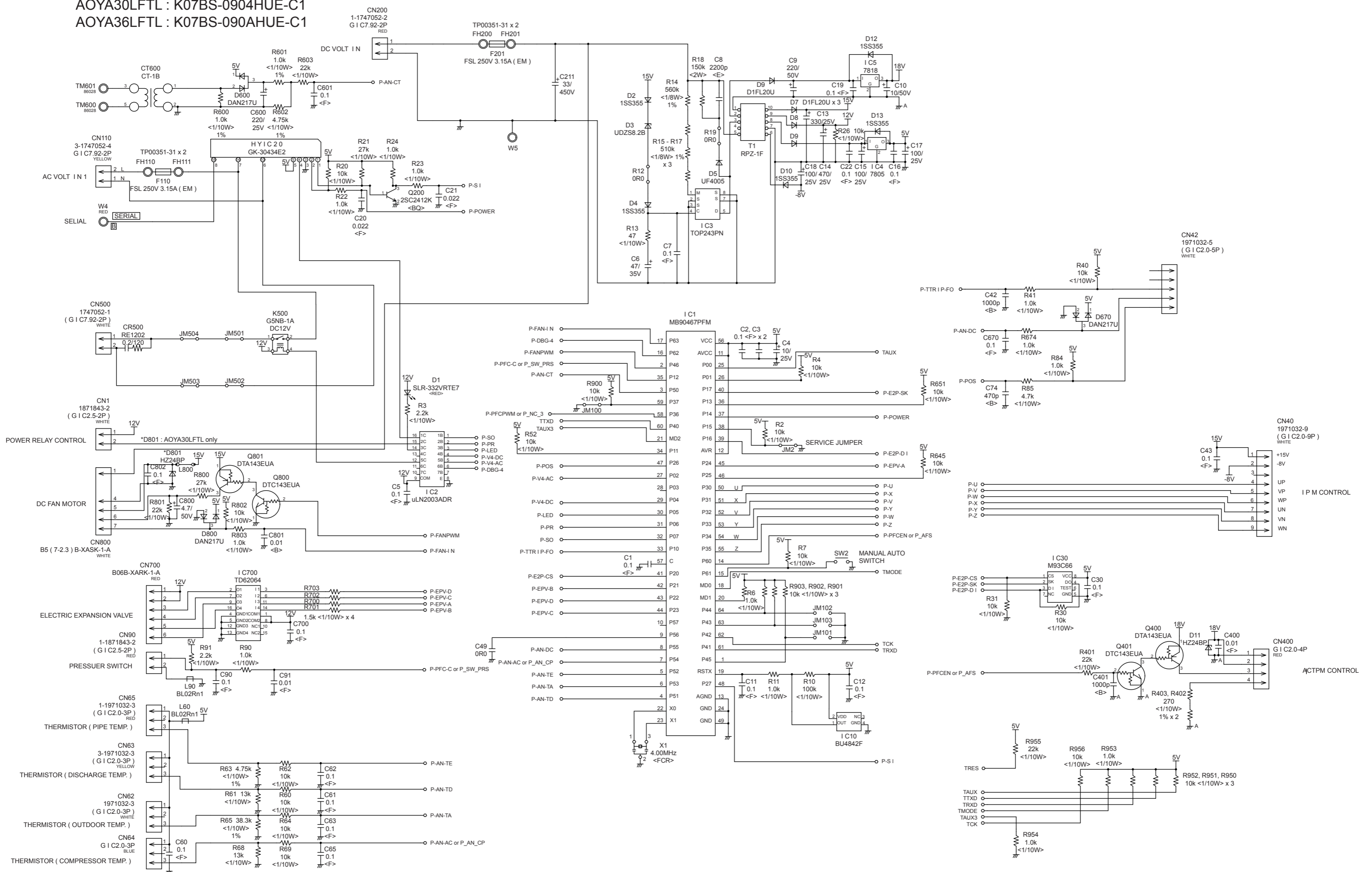

OUTDOOR UNIT
 TRANSISTOR PCB ASSEMBLY (IPM PCB)
 AOYA30LFTL : K07BT-0901HUE-TR0
 AOYA36LFTL : K07BT-0900HUE-TR0

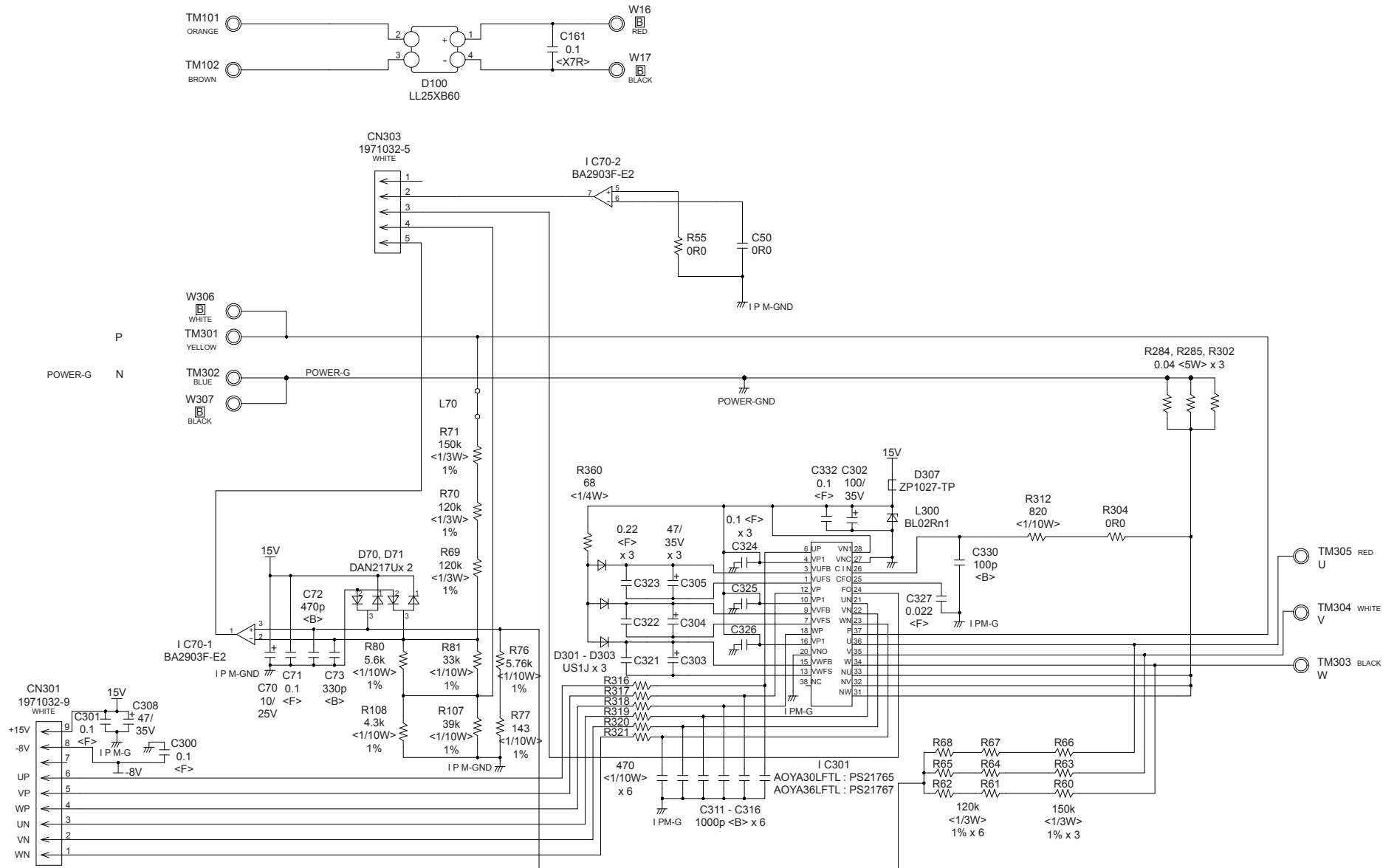

OUTDOOR UNIT
AOYA30LFTL
POWER SUPPLY PCB ASSEMBLY
K05CW-0901HUE-FL0

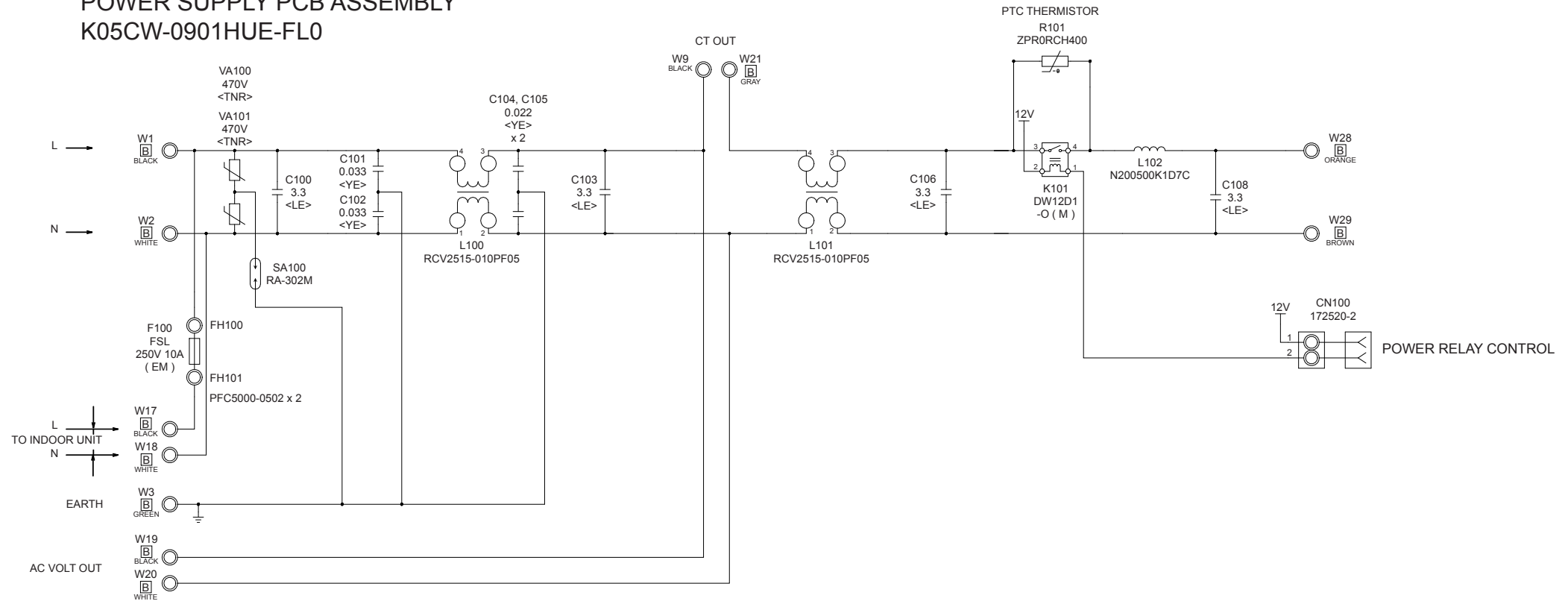

AOYA36LFTL
POWER SUPPLY PCB ASSEMBLY
K05CW-0900HUE-FL0

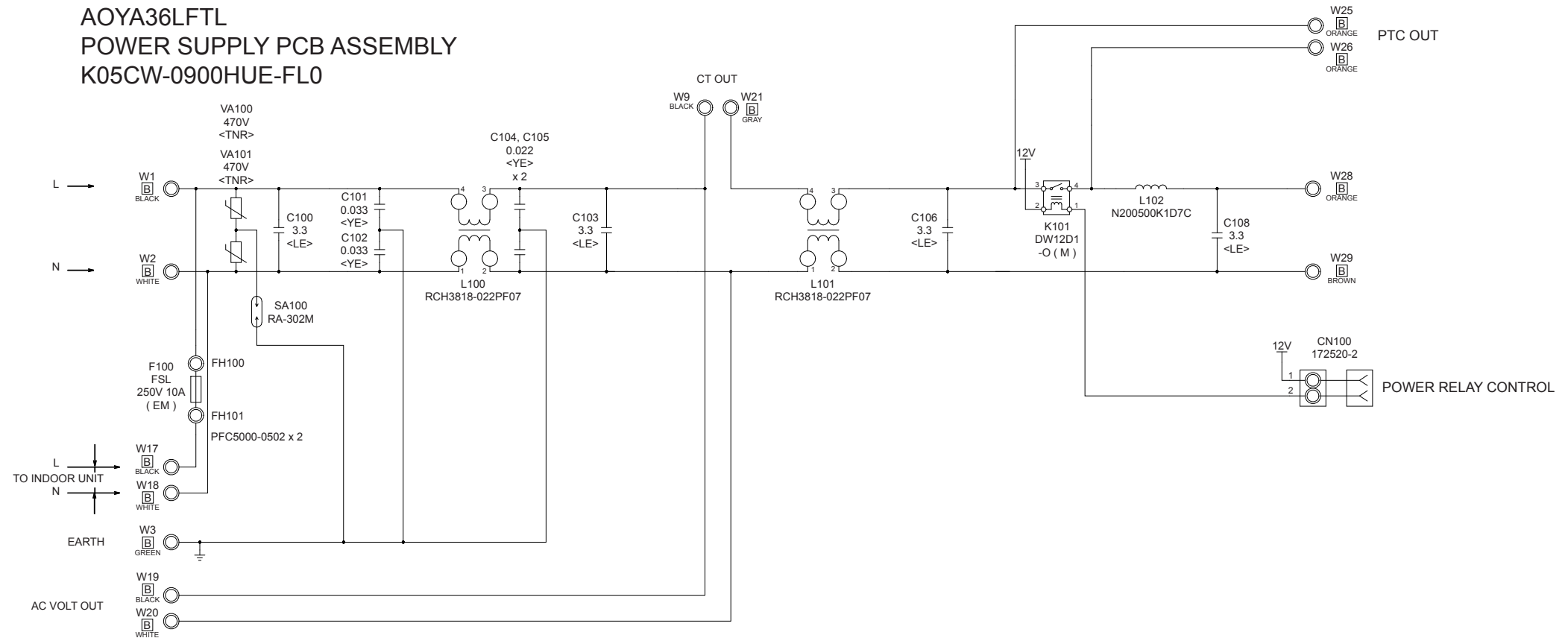

OUTDOOR UNIT
 AOYA30LFTL
 CAPACITOR PCB ASSEMBLY
 K05FB-0901HUE-P0

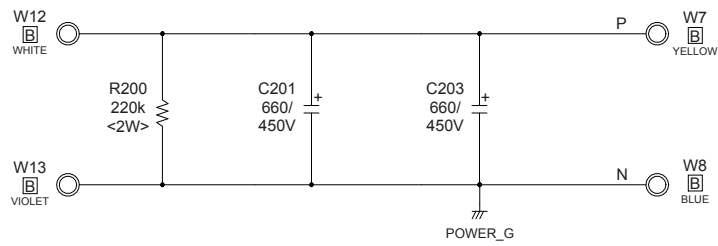

AOYA36LFTL
 CAPACITOR PCB ASSEMBLY
 K05FB-0900HUE-P0

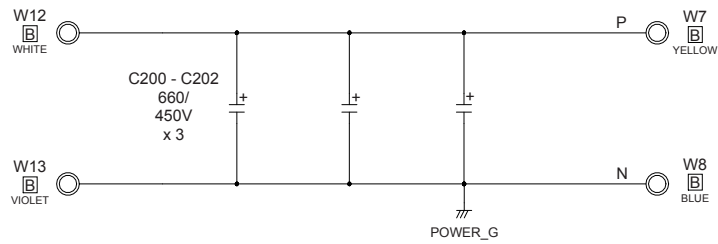

ERROR DETECTION

REMOTE CONTROL

Troubleshooting at the remote control LCD

This is possible only on the wired remote control.

If an error occurs, the following display will be shown.
("EE" will appear in the set room temperature display.)

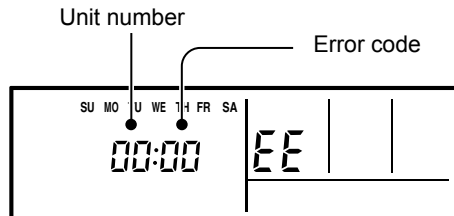

Code	Error contents
01 13 26 27	Indoor signal error
00	Wired remote controller abnormal
02	Indoor room temperature sensor error
04	Indoor heat exchanger temperature sensor (middle) error
28	Indoor heat exchanger temperature sensor (inlet) error
09	Float switch operated
0C	Outdoor discharge pipe temperature sensor error
06	Outdoor heat exchanger temperature sensor (outlet) error
0A	Outdoor temperature sensor error
15	Compressor temperature sensor error
20	Indoor manual auto switch abnormal
2A	Power supply frequency detection error
17	IPM protection
18	CT error
1A	Compressor location error
1b	Outdoor fan error
12	Indoor fan abnormal
0F	Discharge temperature error
24	Excessive high pressure protection on cooling
2c	4-way valve abnormal
16	Pressure switch abnormal
2b	Compressor temperature error
19	Active filter abnormal
25	PFC circuit error

If "CO" appears in the unit number display, there is a remote control error. Refer to the installation instruction sheet included with the remote control.

OUTDOOR UNIT

⚠ CAUTION

Always turn on the power 12 hours prior to the start of the operation in order to ensure compressor protection

1. Make a TEST RUN in accordance with the installation instruction sheet for the indoor unit.

2. OUTDOOR UNIT LEDS

When a malfunction occurs in the outdoor unit, the LED on the circuit board lights to indicate the error. Refer to the following table for the description of each error according to the LED.

LED	ERROR CONTENTS
FLASH (0.1sec ON/0.1sec OFF)	Temperature sensor error
FLASH (0.5sec ON/0.5sec OFF)	IPM protection
FLASH (2sec ON/2sec OFF)	Current trans. error
FLASH (5sec ON/5sec OFF)	Outdoor fan error
FLASH (0.1sec ON/2sec OFF)	Compressor rotor position cannot be detected
FLASH (5sec ON/0.1sec OFF)	ACTPM error
Lighting	Overheat discharge temperature protection

SPECIAL INSTALLATION SETTING

PUMP DOWN (Refrigerant collecting operation)

Perform the following procedures to collect the refrigerant when moving the indoor unit or the outdoor unit.

- (1) Press the push-button switch on the circuit board once.
The LED on the circuit board starts flashing (one second ON/one second OFF). This indicates the start of PUMP DOWN operation.
When the switch is pressed while the compressor is in operation, PUMP DOWN operation starts automatically.
When the switch is pressed while the compressor is in stop, the compressor starts to operate automatically, and then move on to PUMP DOWN operation.
- (2) PUMP DOWN operation continues for about 1 minute. When PUMP DOWN operation is completed, the compressor stops automatically. Then close the 2-way valve and 3-way valve immediately.
- (3) Turn the power off.

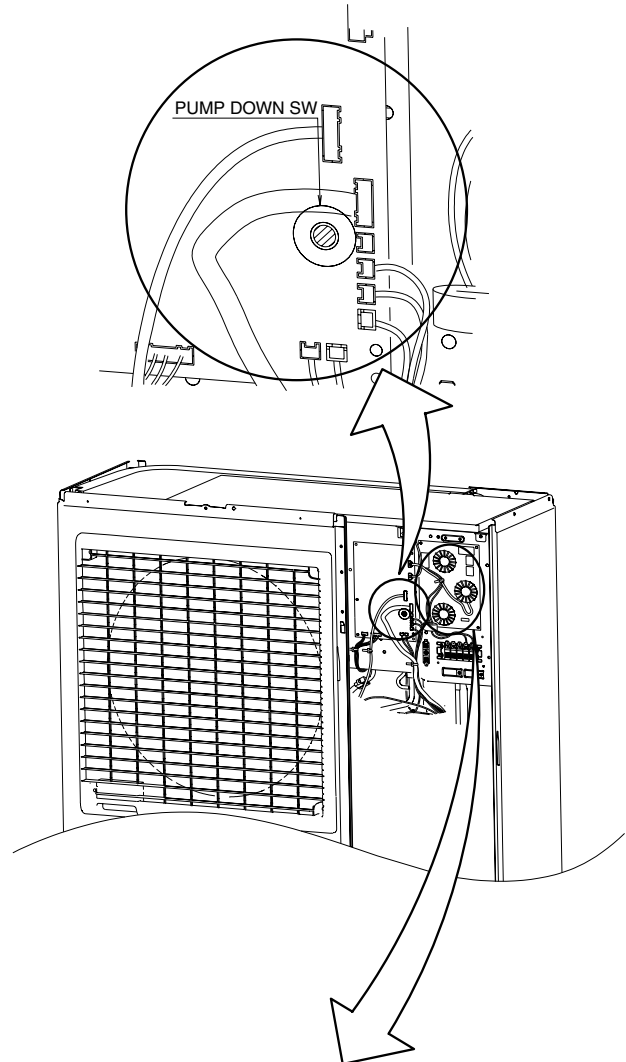

⚠ DANGER

This part (Choke coil) generates high voltages. Never touch this part.

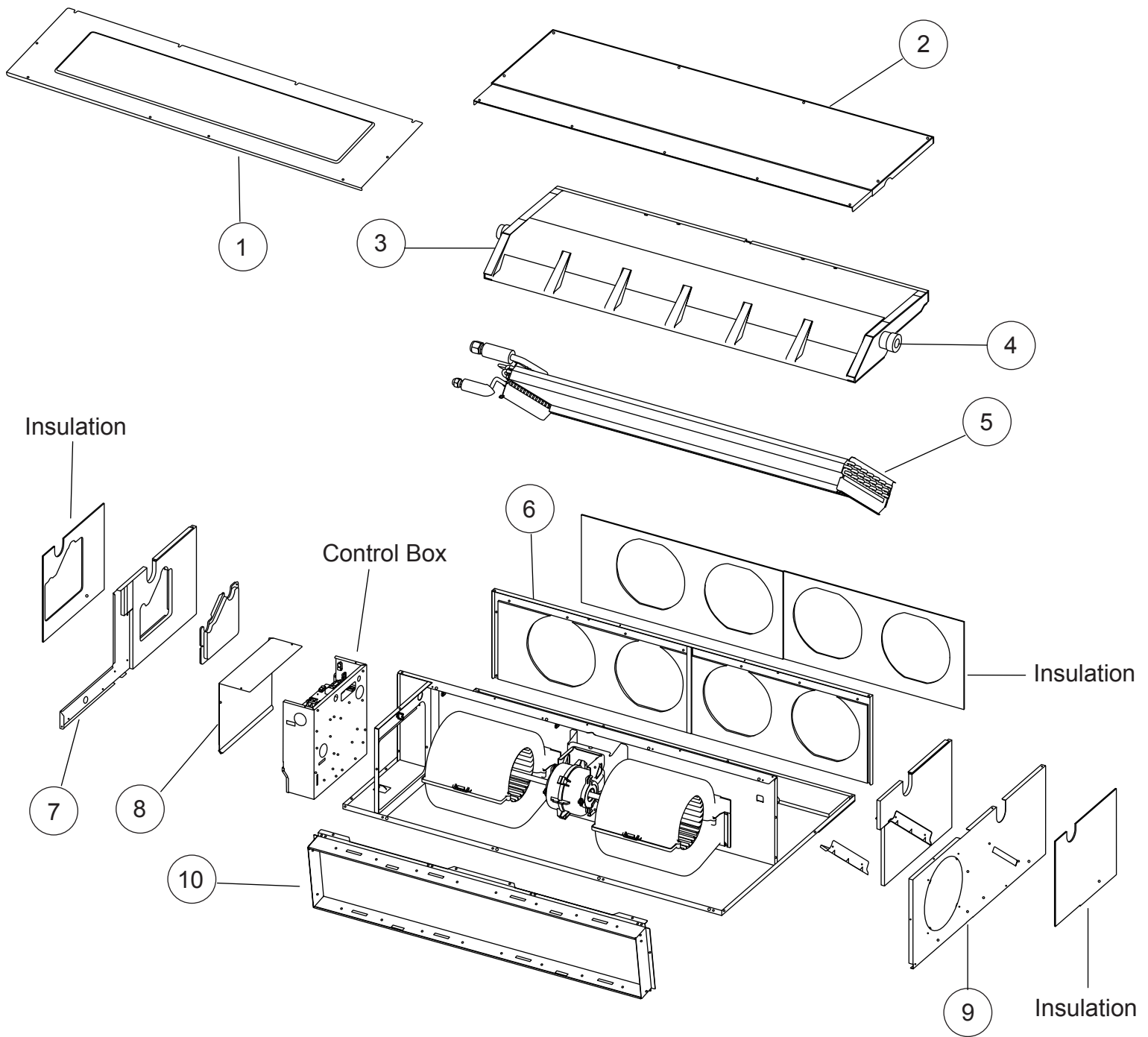

PARTS

INDOOR UNIT

Ref.	Description	Part number
1	Intake Cover Sub Assy	9374512010
2	Main Panel Sub Assy	9374511013
3	Drain Pan Sub Assy	9374513017
4	Drain Cap	9356541007
5	Evaporator Assy	9374518012
6	Outlet Panel Sub Assy	9374510016
7	Cabinet R Sub Assy	9374508020
8	Control Cover A Sub Assy	9374516018
9	Cabinet L Sub Assy	9374509010
10	Intake Frame Assy	9374216017
--	Distributor Assy	9371325439
--	Coupling Pipe Assy	9371333052
--	Seal Panel Sub Assy	9374515011
--	Bracket Pipe Sub Assy	9374514014
--	Thermo Holder Pipe	313714262805
--	Thermistor Spring A	313728262708

INDOOR UNIT

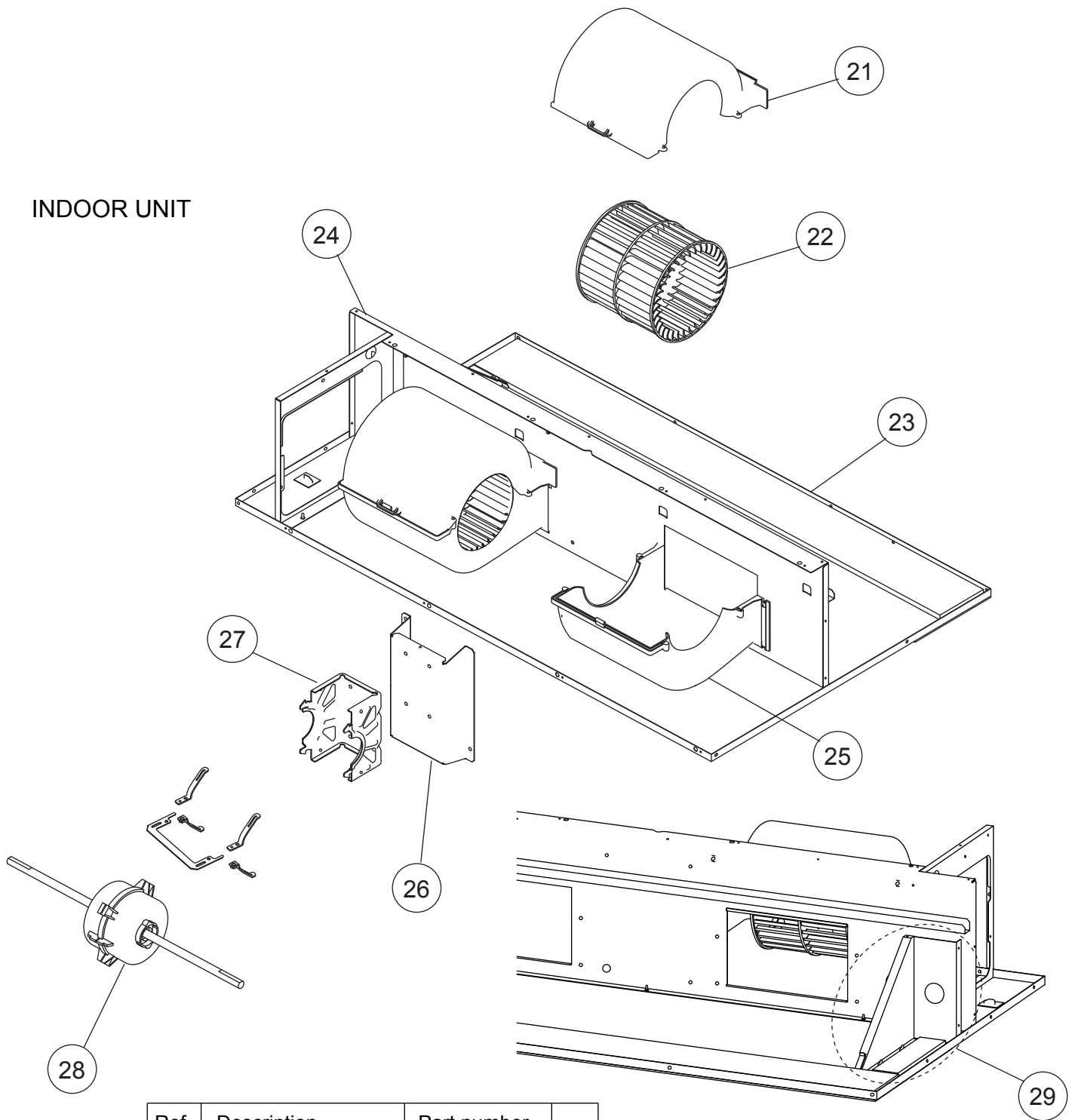

Ref.	Description	Part number
21	Casing B	9374234011
22	Sirocco Fan Assy	9356531046
23	Base Sub Assy	9374504015
24	Separate Wall Assy	9374228010
25	Casing A	9374233014
26	Bracket Motor Assy	9374230013
27	Motor Mount	9378002012
28	Fan Motor	9602466016
29	Bracket (Eva) R	9374207015
--	Bracket (Eva) L	9374208012
--	Panel (Control Box)	9374210015
--	Cap (Power)	9352173011
--	Motor Band	9378031012

INDOOR UNIT
Control unit

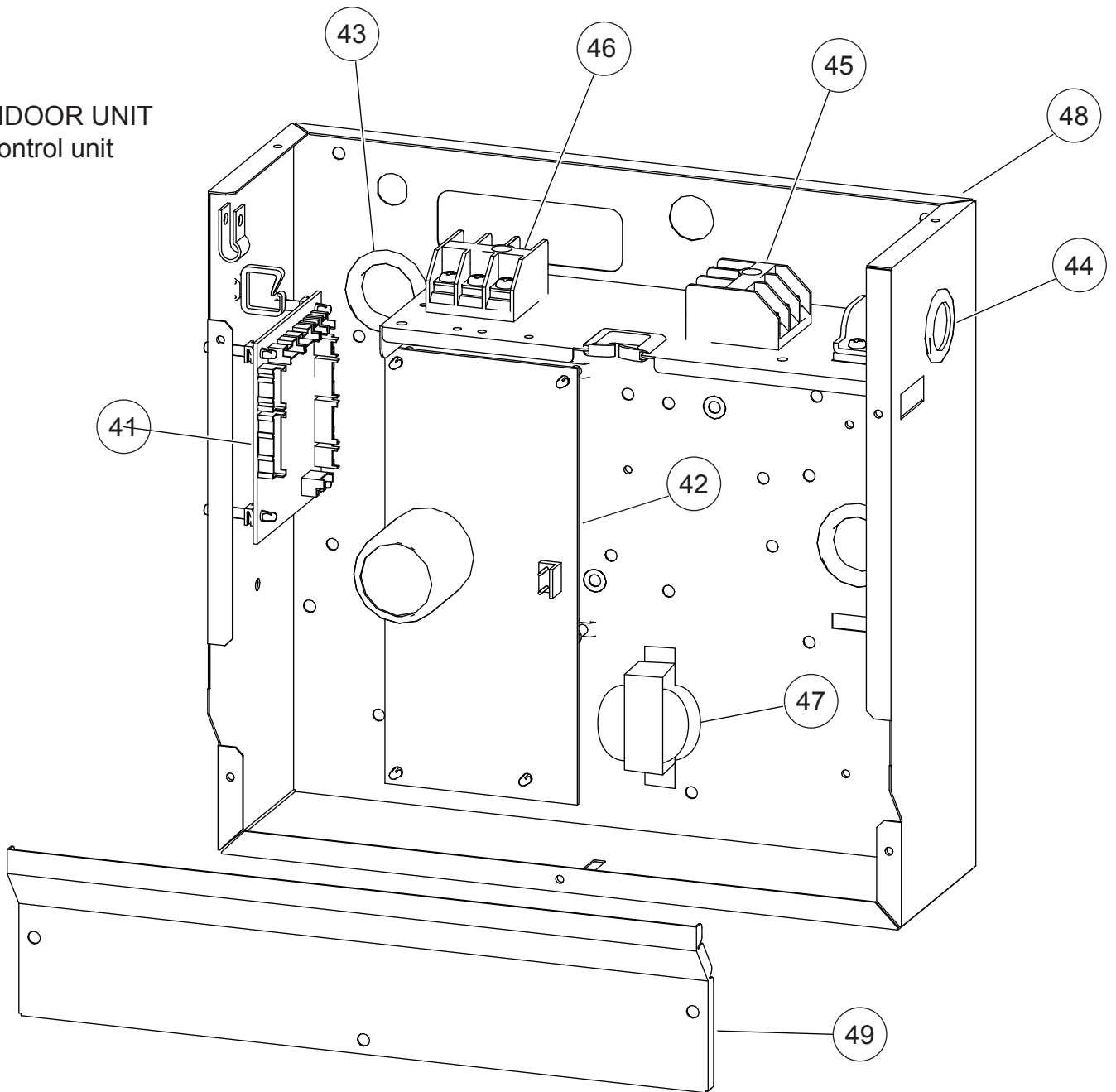

Ref.	Description	Part number	
41	Controller PCB Assy (30)	9707393293	
41	Controller PCB Assy (36)	9707393309	
42	Power Supply PCB Assy	9707398069	
43	Cap (Power)	9352173011	
44	One Touch Bush	9374407019	
45	Terminal 3P	9703345012	
46	Terminal 3P	9306489045	
47	Reactor Assy	9707457018	
48	Control Box A	9374219018	
49	Control Cover B	9374222018	
--	Control Box B	9374220014	
--	Room Thermistor	9703299025	
--	Pipe Thermistor	9703297021	
--	Remote Control	9372266199	
--	Wire Assembly	9372714010	

PARTS

OUTDOOR UNIT

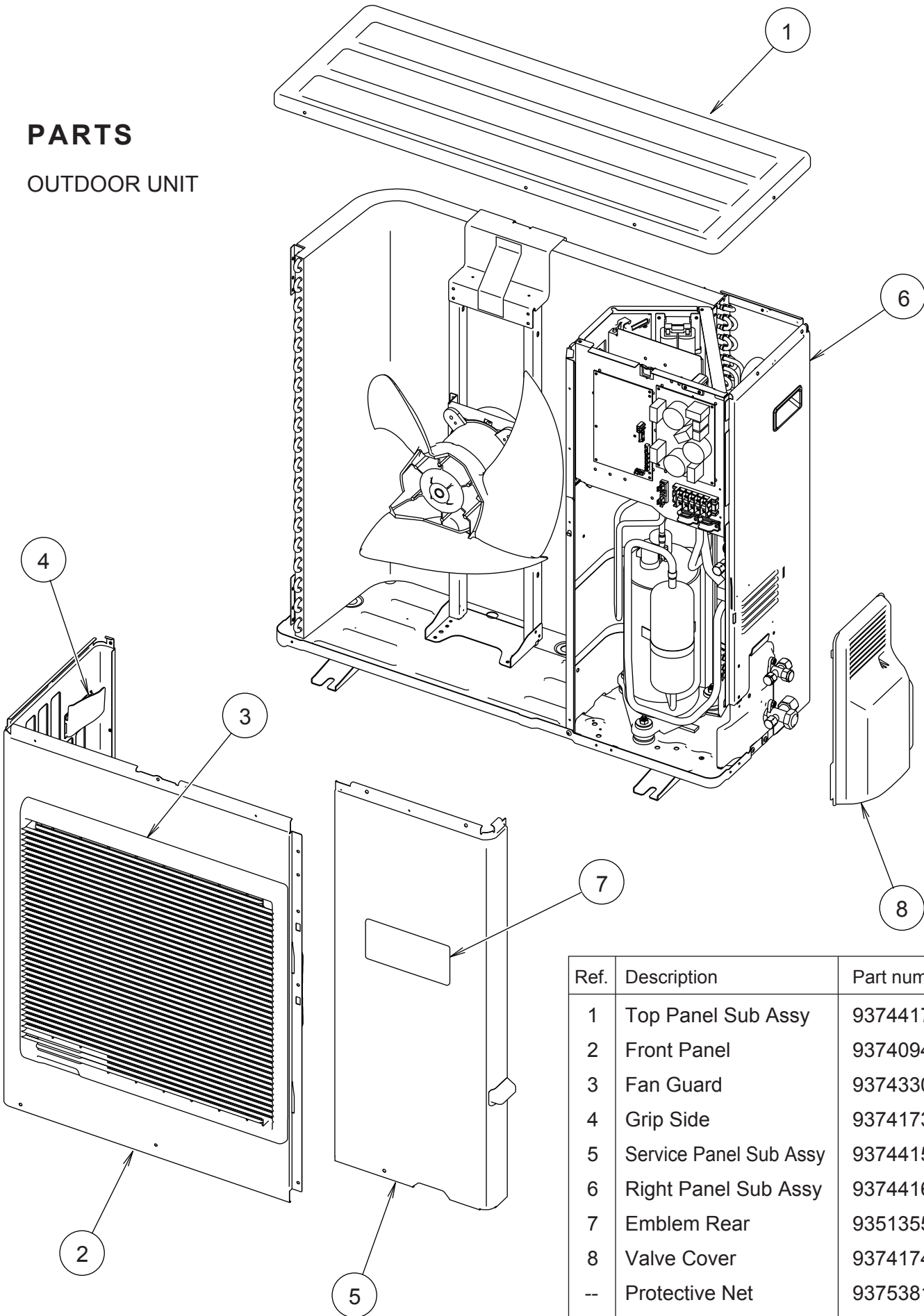

Ref.	Description	Part number
1	Top Panel Sub Assy	9374417032
2	Front Panel	9374094066
3	Fan Guard	9374330010
4	Grip Side	9374173013
5	Service Panel Sub Assy	9374415052
6	Right Panel Sub Assy	9374416127
7	Emblem Rear	9351355005
8	Valve Cover	9374174010
--	Protective Net	9375381011
--	Fan Guard Cover	9378111011

OUTDOOR UNIT

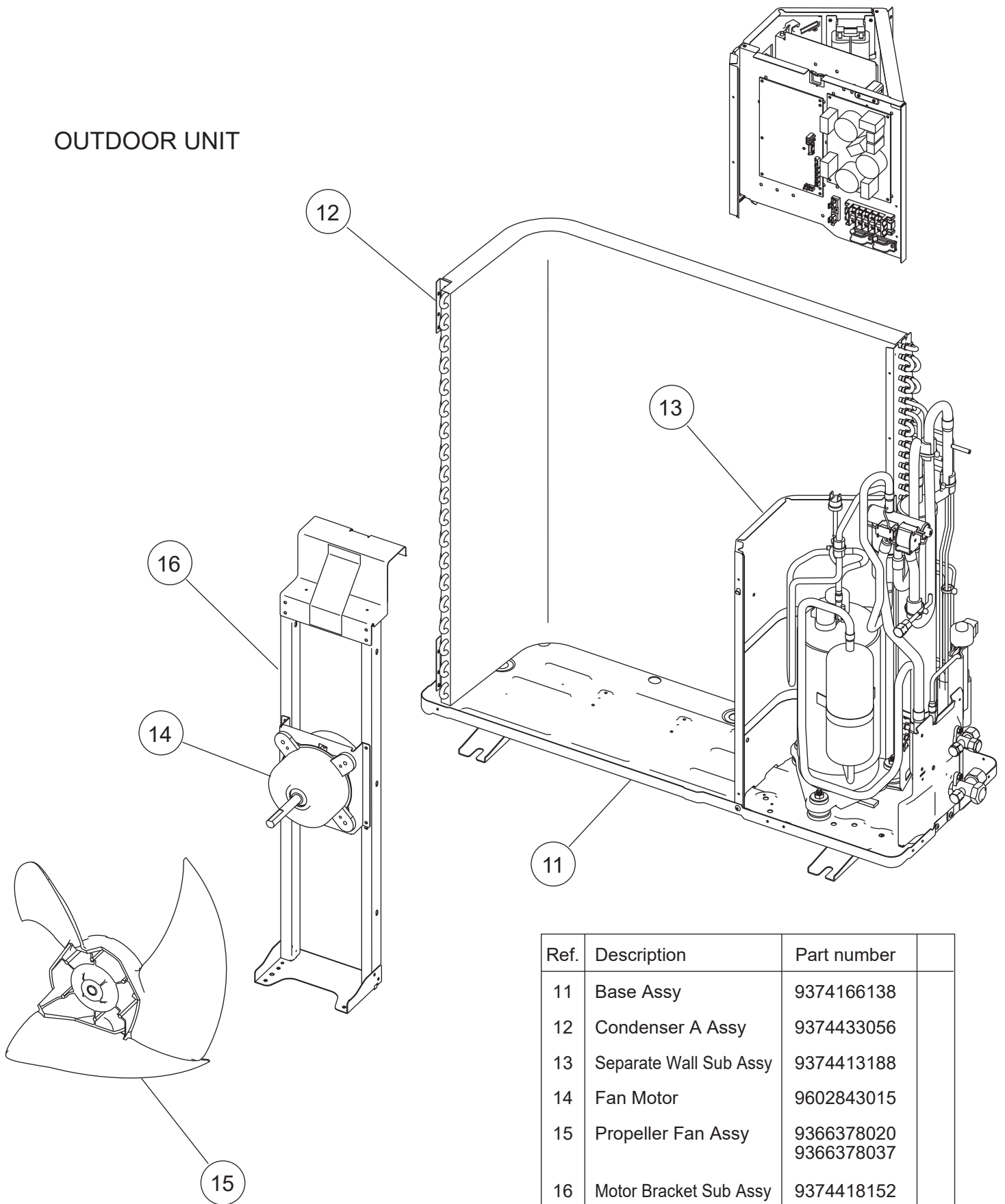

Ref.	Description	Part number
11	Base Assy	9374166138
12	Condenser A Assy	9374433056
13	Separate Wall Sub Assy	9374413188
14	Fan Motor	9602843015
15	Propeller Fan Assy	9366378020 9366378037
16	Motor Bracket Sub Assy	9374418152
--	Valve Plate	9374099030

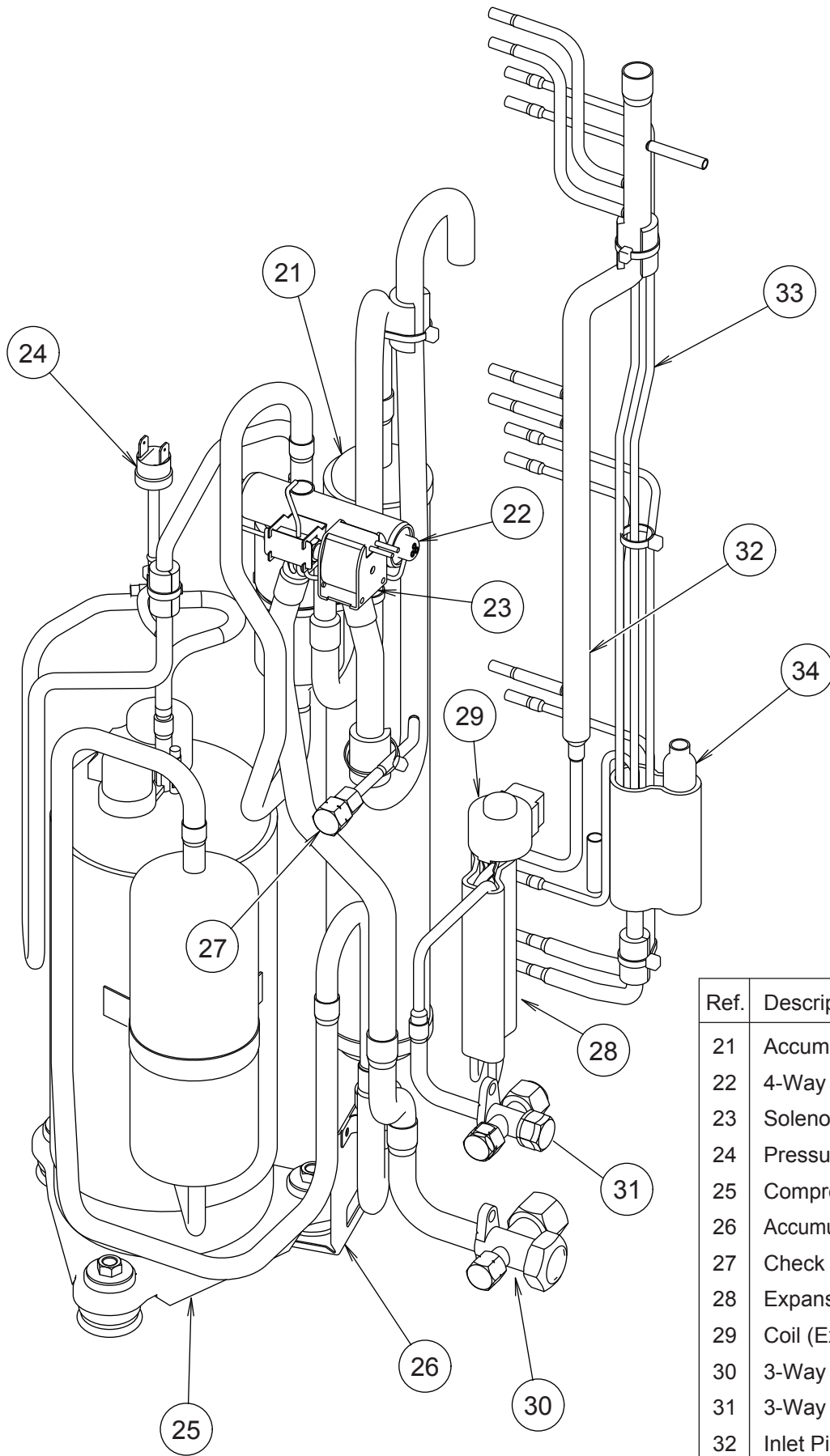

OUTDOOR UNIT

Ref.	Description	Part number
21	Accumulator	9385005006
22	4-Way Valve	9900164010
23	Solenoid	9970055034
24	Pressure Switch	9900186012
25	Compressor Assy	9810135001
26	Accumulator Support Assy	9355351003
27	Check Joint Assy	9372802038
28	Expansion Valve Assy	9370947144
29	Coil (Expansion Valve)	9900057039
30	3-Way Valve Assy	9377959010
31	3-Way Valve Assy	9377958013
32	Inlet Pipe (Cond) A Assy	9373461067
33	Outlet Pipe (Cond) A Assy	9374266104
34	Strainer Assy	9372524015
--	Discharge Pipe Assy	9372264249



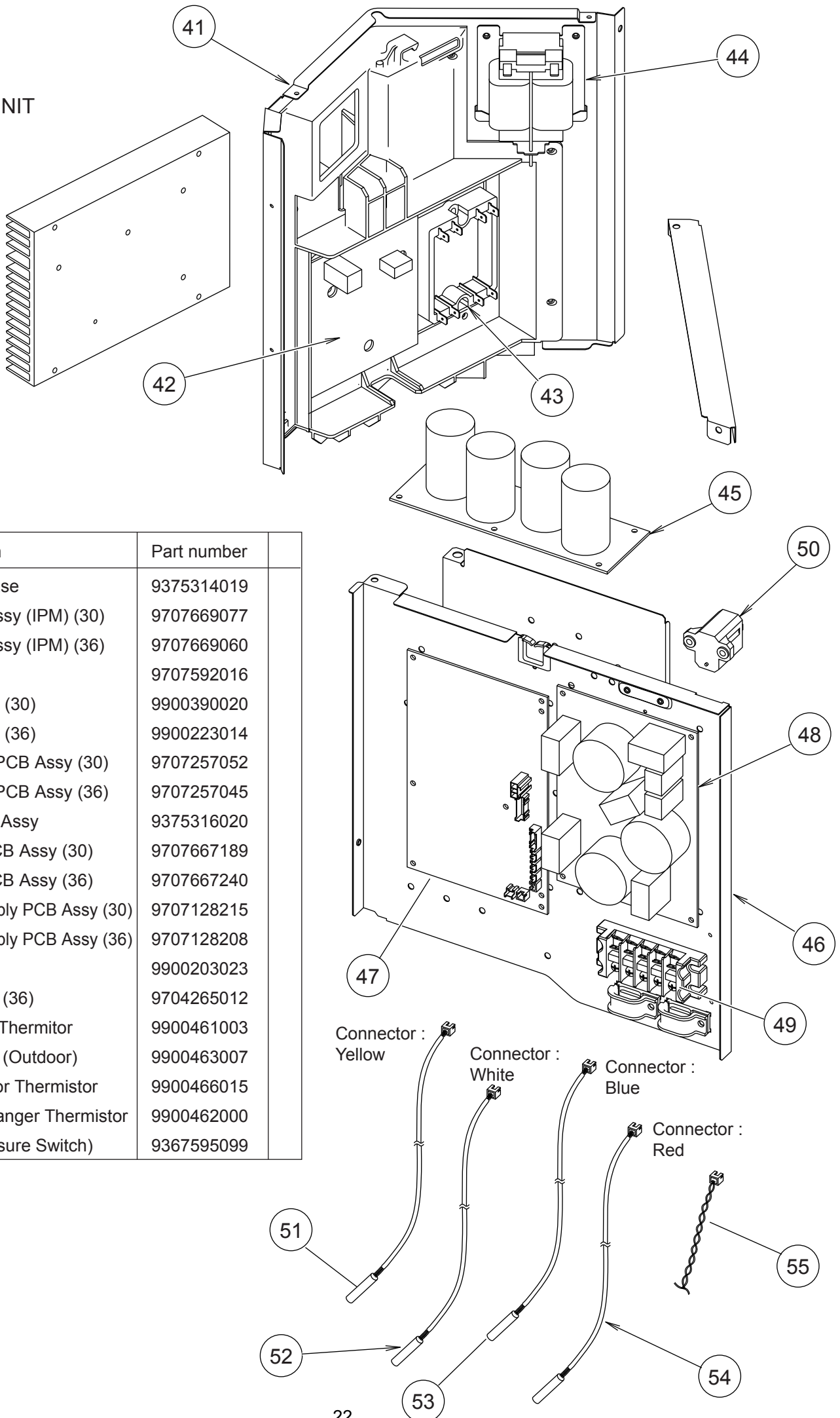



OUTDOOR UNIT



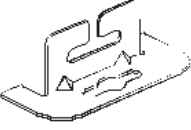

Ref.	Description	Part number
41	Inverter Case	9375314019
42	TR PCB Assy (IPM) (30)	9707669077
42	TR PCB Assy (IPM) (36)	9707669060
43	ACTPM	9707592016
44	Choke Coil (30)	9900390020
44	Choke Coil (36)	9900223014
45	Capacitor PCB Assy (30)	9707257052
45	Capacitor PCB Assy (36)	9707257045
46	PCB Case Assy	9375316020
47	Inverter PCB Assy (30)	9707667189
47	Inverter PCB Assy (36)	9707667240
48	Power Supply PCB Assy (30)	9707128215
48	Power Supply PCB Assy (36)	9707128208
49	Terminal	9900203023
50	Thermistor (36)	9704265012
51	Discharge Thermistor	9900461003
52	Thermistor (Outdoor)	9900463007
53	Compressor Thermistor	9900466015
54	Heat Exchanger Thermistor	9900462000
55	Wire (Pressure Switch)	9367595099

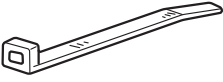
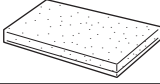
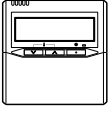
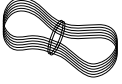
ACCESSORIES

INDOOR UNIT

Name and Shape	Q'ty	Application
Hanger 	4	For suspending the indoor unit from ceiling
Special nut A (large flange) 	4	For suspending the indoor unit from ceiling
Special nut B (small flange) 	4	
Coupler heat insulation (large) 	1	For indoor side pipe joint (large pipe)
Coupler heat insulation (small) 	1	For indoor side pipe joint (small pipe)
Binder 	1 (large)	For fixing the drain hose
	1 (small)	For fixing the remote controller cord
Drain hose insulation 	1	Insulates the drain hose and vinyl hose
Remote control 	1	For air conditioner operation
Remote control cord (*1) 	1	For connecting the remote control
Tapping screw (ø4 × 16) 	2	For installing the remote control

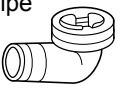
OUTDOOR UNIT

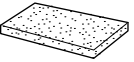
Name and Shape	Q'ty	Application	Part number
Drain pipe 	1	For outdoor unit drain piping work (May not be supplied, depending on the model)	9303029015
Drain cap 	2		313166024302
Installation (seal) 	1	For filling in a gap at the entrance of connection cords	9374756018

OPTIONAL PARTS

Square flange

Model name : UTD-SF045T (P/N 9098180007)

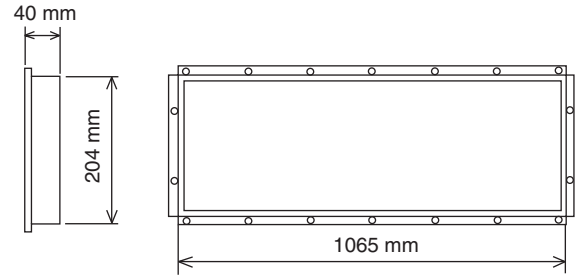

Flexible duct

Model name : UTD-RD202 (P/N 9074165004)



Round flange

Model name : UTD-RF204 (P/N 9093160004)

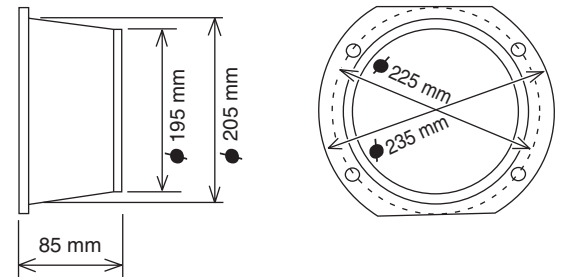

Long-life filter

Model name : UTD-LF25NA (P/N9079892004)

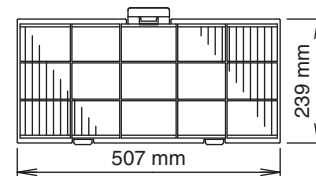

Remote sensor

Model name : UTD-RS100 (P/N9072619004)

External control set

Model name : UTD-ECS5A (P/N 9077359004)

0911G3683