

FUJII ELECTRIC

INVERTER SPLIT TYPE AIR CONDITIONER

CASSETTE type (50Hz)

SERVICE MANUAL

Models	Indoor unit	Outdoor unit
	RC-18LA	ROT-18LA
	RC-24LA	ROT-24LA



C O N T E N T S

SPECIFICATIONS	1
DIMENSIONS	3
CIRCUIT DIAGRAM	6
REFRIGERANT SYSTEM DIAGRAM	8
ERROR CONTENTS	10
INDOOR PRINTED CIRCUIT BOARD CIRCUIT DIAGRAM ...	11
OUTDOOR PRINTED CIRCUIT BOARD CIRCUIT DIAGRAM ..	13
DISASSEMBLY ILLUSTRATION	14
PARTS LIST	22
STANDARD ACCESSORIES	25

S P E C I F I C A T I O N S

TYPE		COOLING & HEATING	
INDOOR UNIT		RC-18LA	RC-24LA
OUTDOOR UNIT		ROT-18LA	ROT-24LA
COOLING CAPACITY	(kW)	4.70	7.10
HEATING CAPACITY	(kW)	4.80	7.80

ELECTRICAL DATA

POWER SOURCE		(V)	230	
FREQUENCY		(Hz)	50	
RUNNING CURRENT	(A)	COOLING	7.2	11.1
		HEATING	7.5	10.5
INPUT WATTS	(kW)	COOLING	1.65	2.53
		HEATING	1.71	2.40
E.E.R.	(kW/kW)	COOLING	2.85	2.81
		HEATING	2.81	3.25
STARTING CURRENT		(A)	10	
MOISTURE REMOVAL		(ℓ/hr)	2.0	

COMPRESSOR

TYPE		Hermetic type, 4 poles, DC motor, Twin Rotary	
DISCRIMINATION		TNB220FPCM	
REFRIGERANT	R410A	(g)	1,500 1,800

	DISCRIMINATION	MFA-18GTBT	MFA-30JTT
		FAN SPEED (r.p.m.)	INDOOR
	OUTDOOR HI / LO	780 / 400	
AIR FLOW (m³/h)	INDOOR	620	1,250
	OUTDOOR	2,800	3,200
DIMENSIONS H x W x D (mm)	INDOOR	235 x 580 x 580 + 70	246 x 830 x 830
	OUTDOOR	650 x 830 x 320	
WEIGHT NET / GROSS (kg)	INDOOR	18 / 23	34 / 44
	OUTDOOR	54 / 58	
MAX PIPE LENGTH / HEIGHT (m)		25 / 15	
REMOTE CONTROLLER TYPE		WIRELESS	WIRED

TYPE	COOLING & HEATING	
INDOOR UNIT	RC-18LA	RC-24LA
OUTDOOR UNIT	ROT-18LA	ROT-24LA

NOISE LEVEL

INDOOR UNIT	HI-SPEED (dB)	44	46
	MED-SPEED (dB)	41	43
	LO-SPEED (dB)	38	37
OUTDOOR UNIT	(dB)	COOL 50 / HEAT 52	COOL 52 / HEAT 54

FULL CHARGE AMOUNT	Pipe Length	7.5 m	1,500 g	1,800 g
		10.0 m	1,500 g	1,800 g
		15.0 m	1,600 g	2,000 g
		20.0 m	1,700g	2,200 g
		25.0 m	1,800g	2,400 g
ADDITIONAL REFRIGERANT			20 g / m	40 g / m

When you dismantle indoor units which are installed, take care not to make parts fall down, especially motors.

DIMENSIONS

INDOOR UNIT

Model : RC-18LA

Unit : (mm)

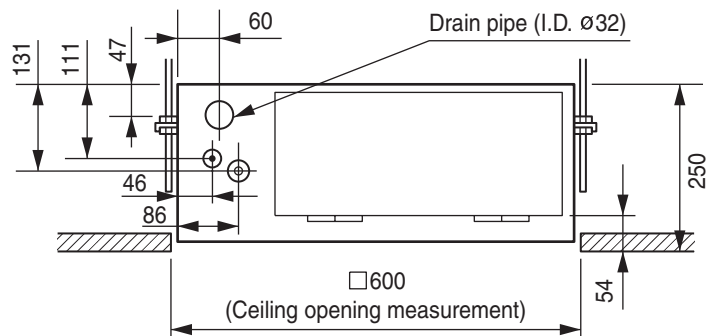
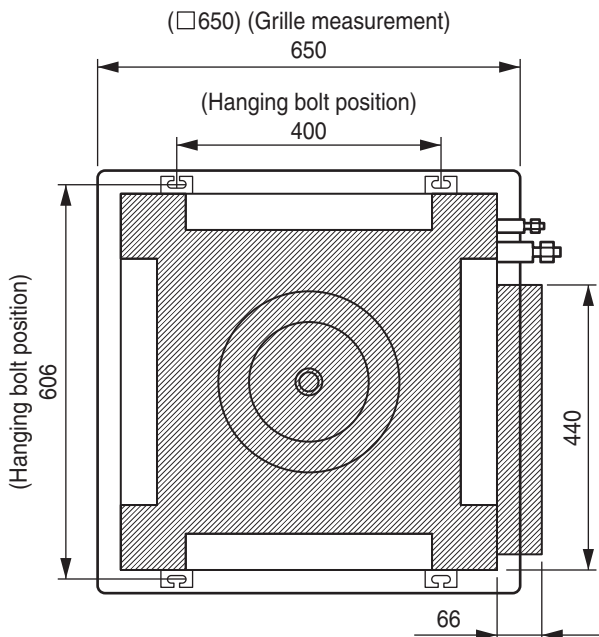
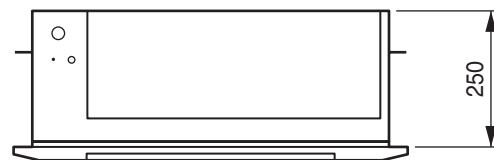
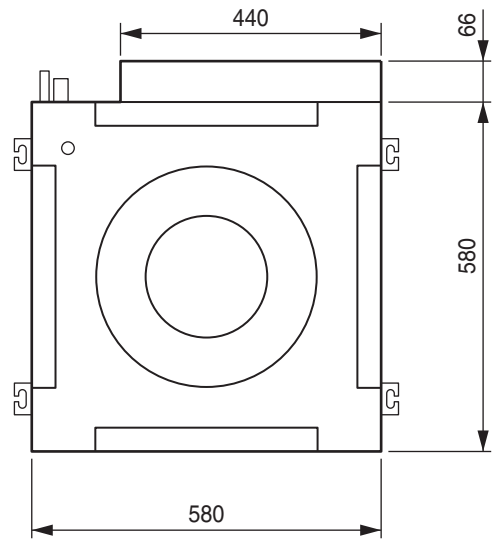
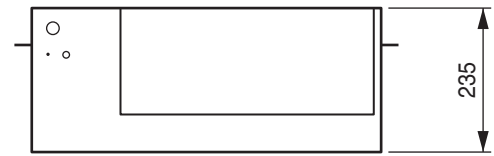
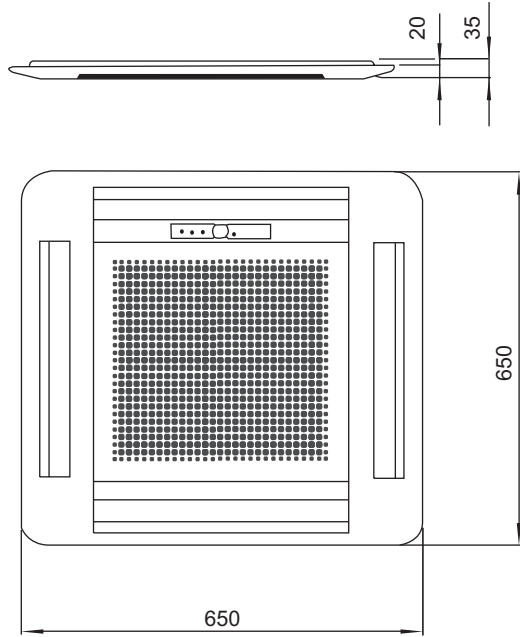

Model : RC-24LA

Unit : (mm)

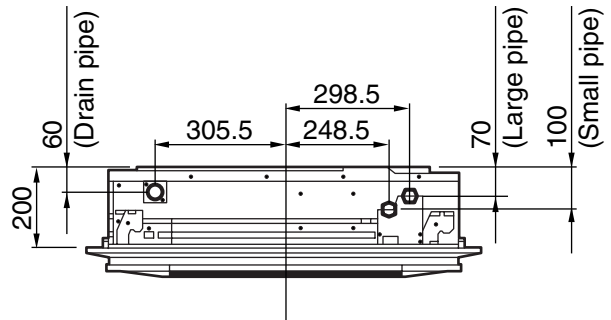
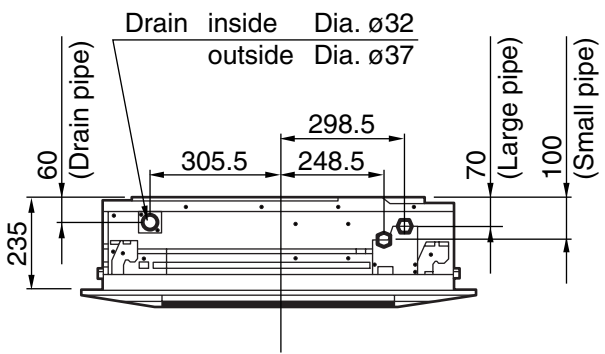
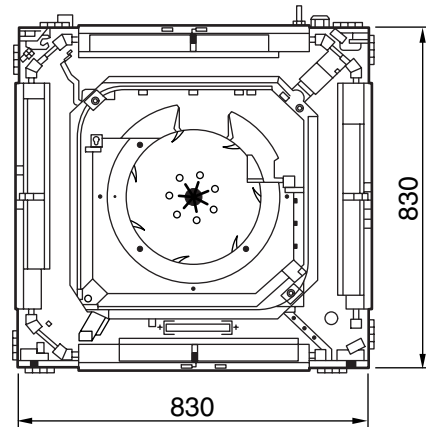
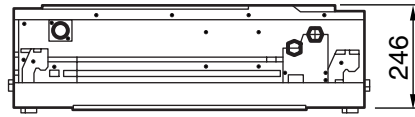
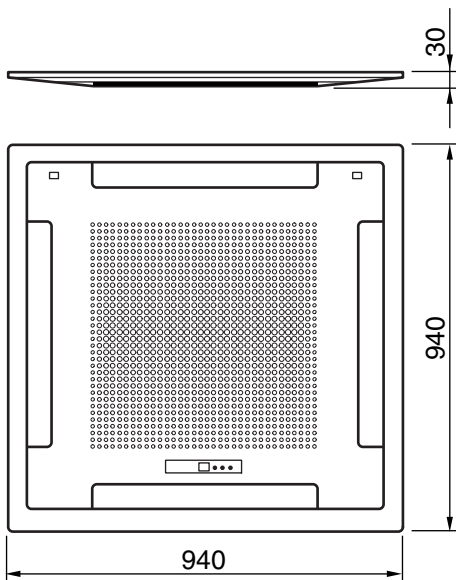

OUTDOOR UNIT

Models : ROT-18LA
ROT-24LA

Unit : (mm)

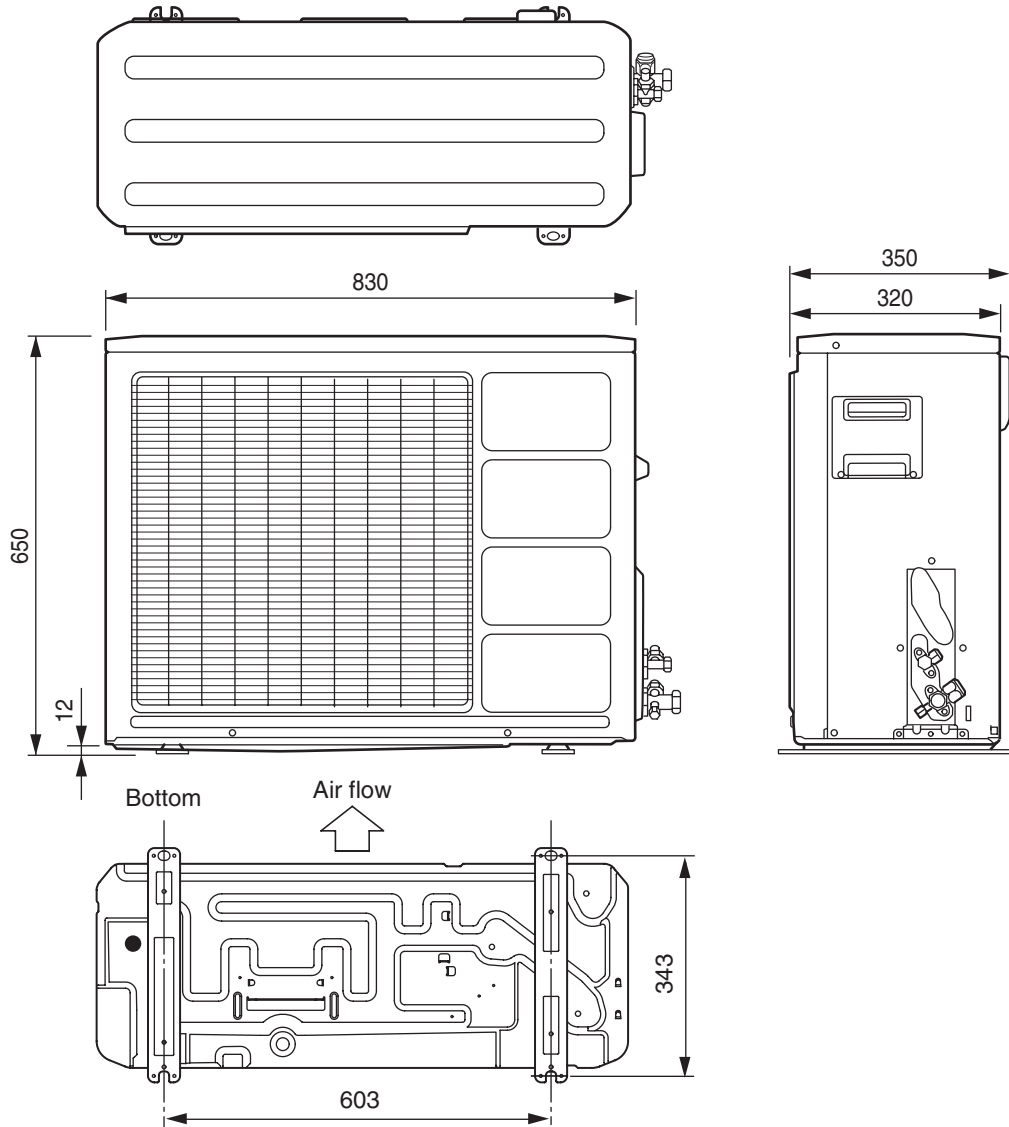

CIRCUIT DIAGRAM

Model : RC-18LA

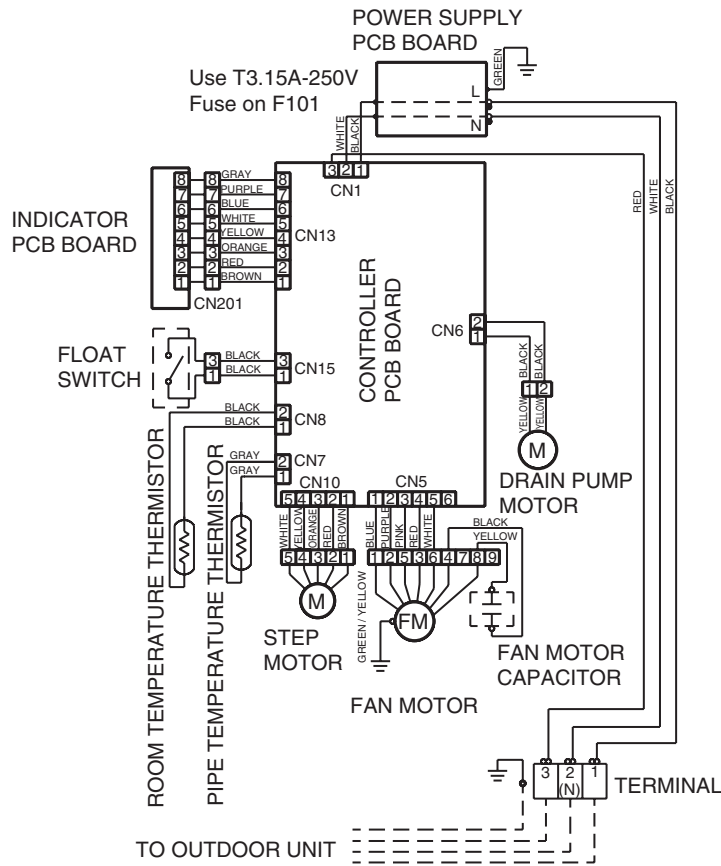

Model : ROT-18LA

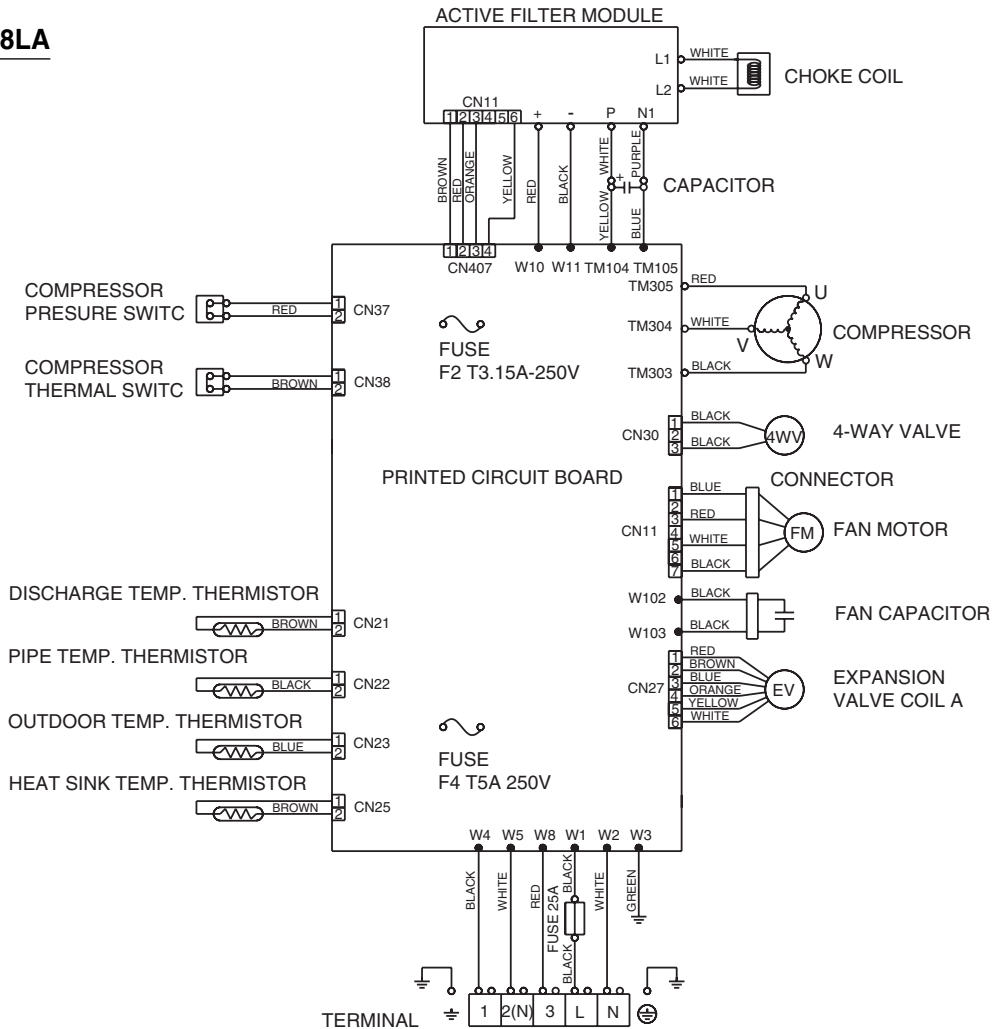

Model : RC-24LA

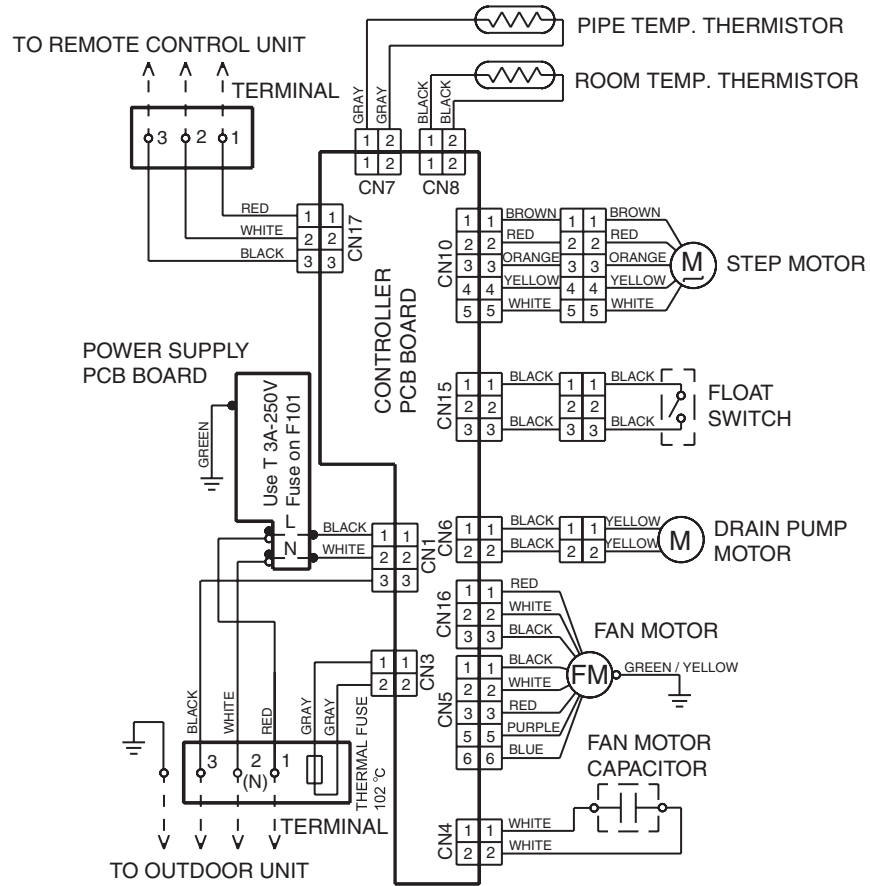

Model : ROT-24LA

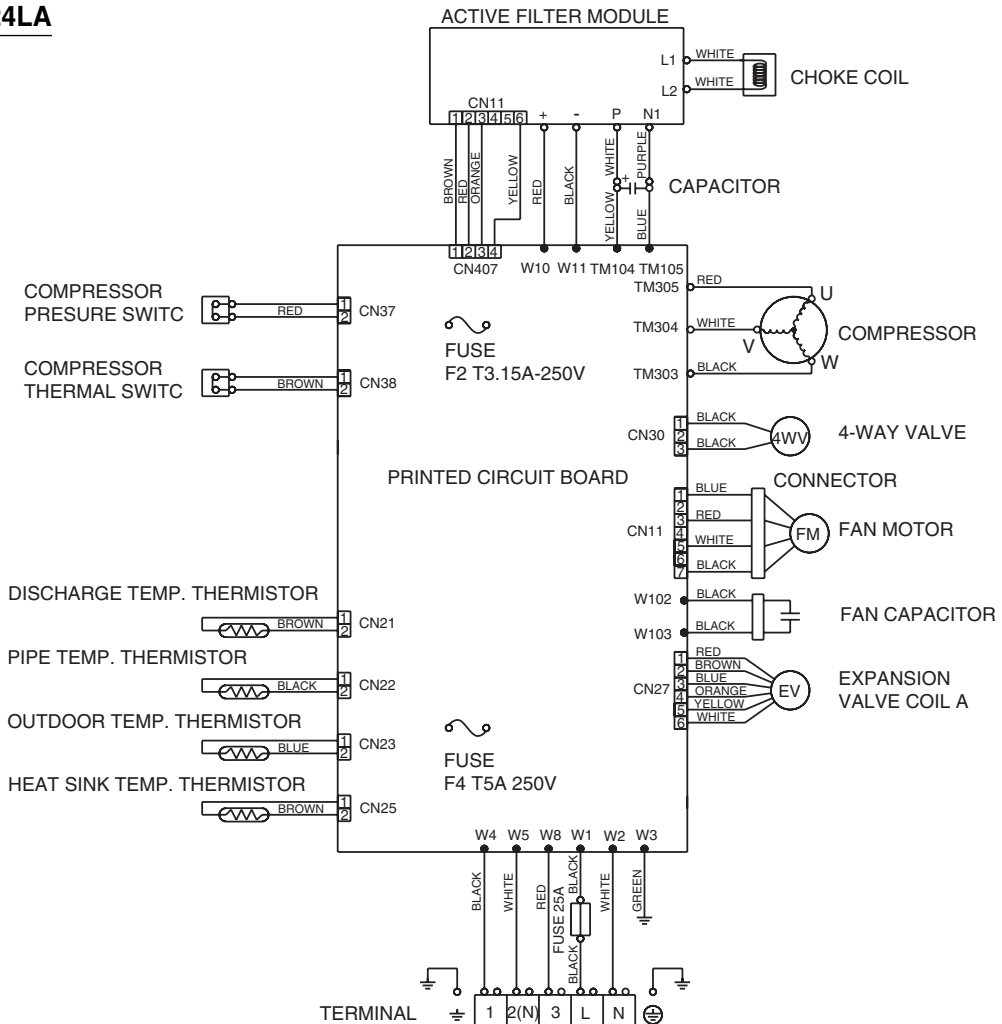

REFRIGERANT SYSTEM DIAGRAM

Models : RC-18LA / ROT-18LA

OUTDOOR UNIT

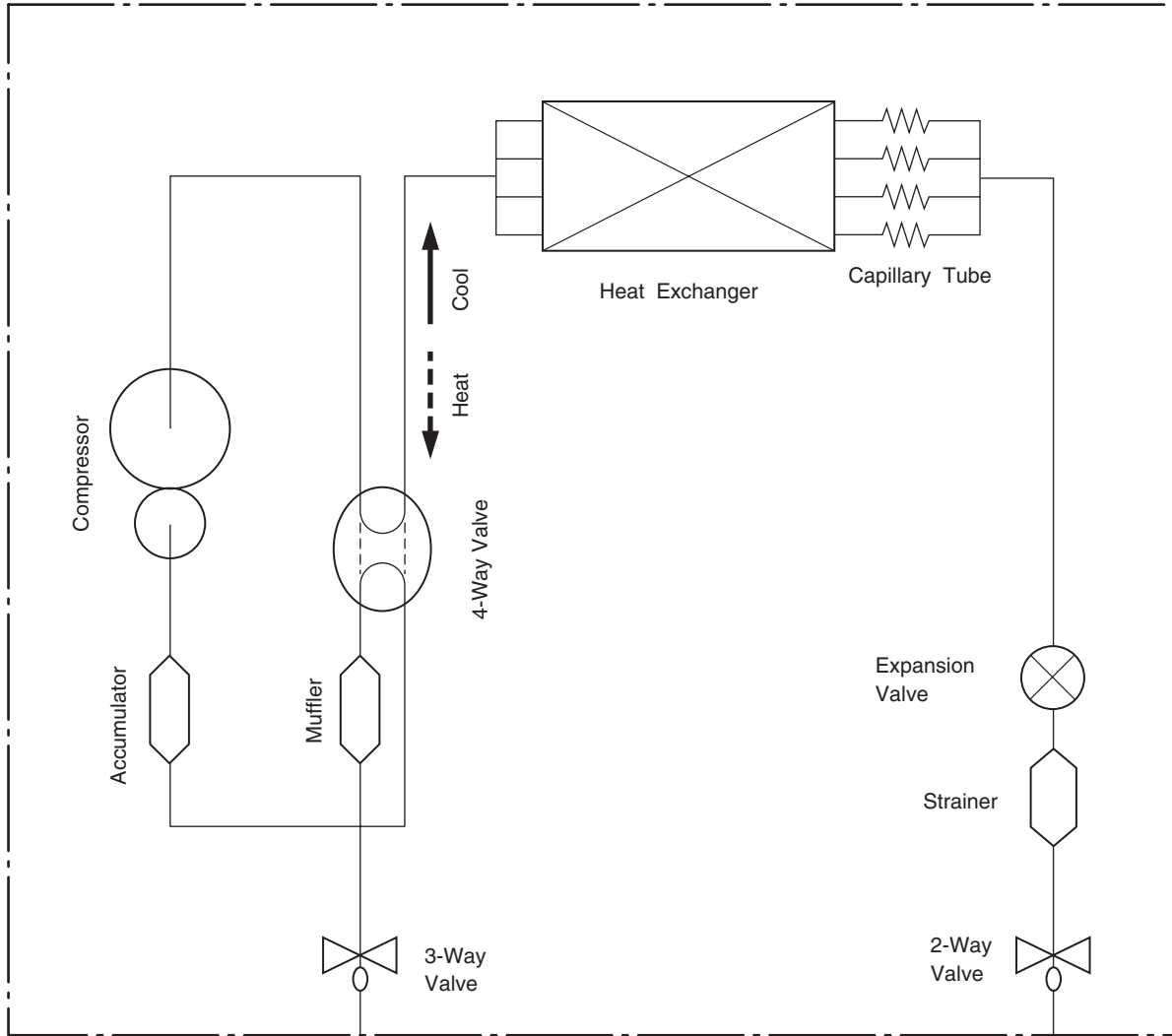

INDOOR UNIT

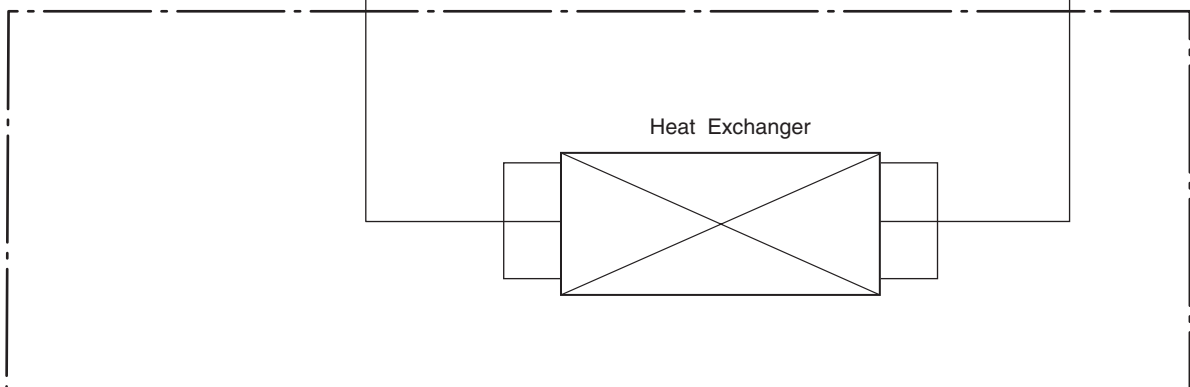

Models : RC-24LA / ROT-24LA

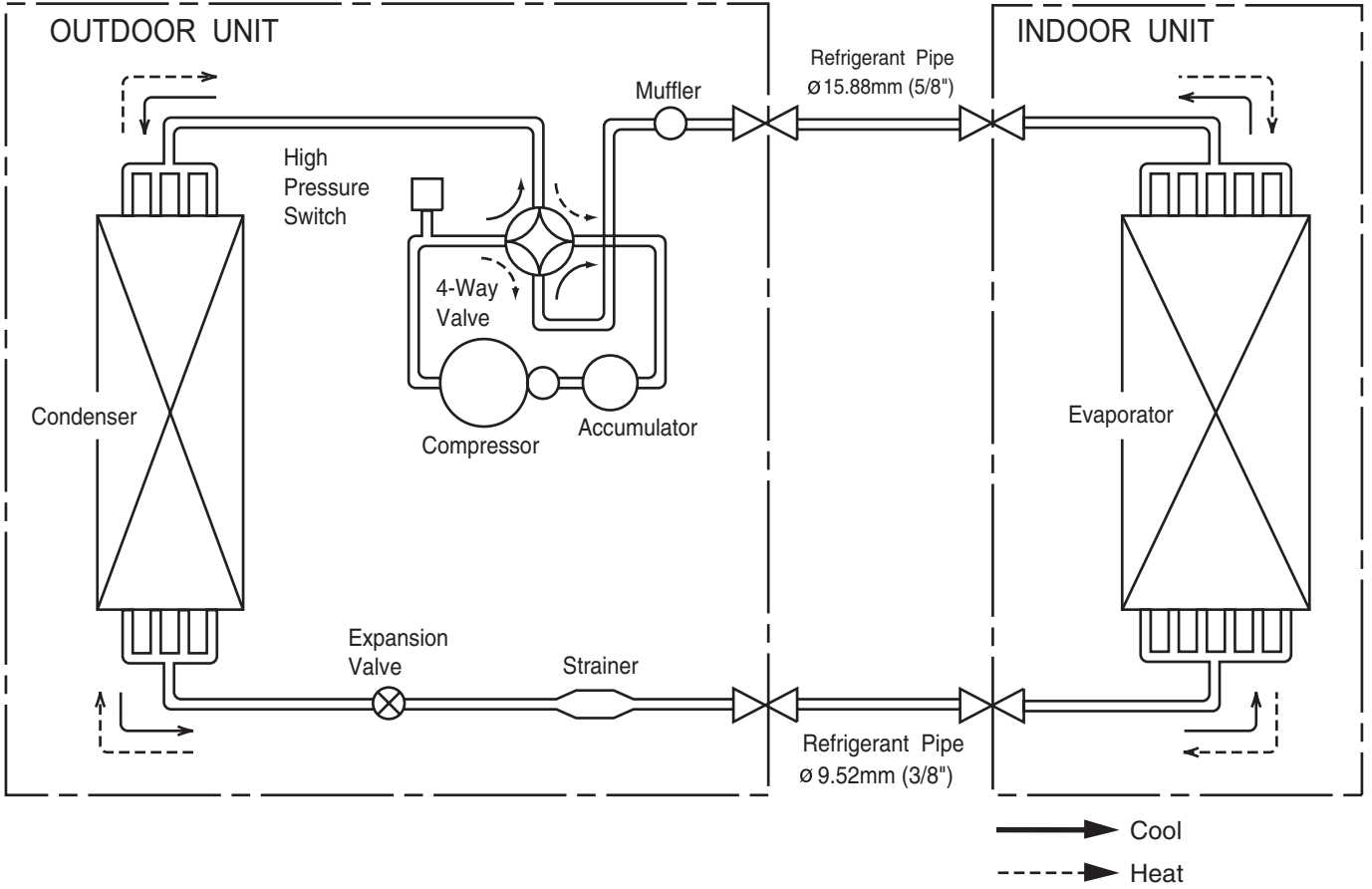

ERROR CONTENTS

- (1) Stop the air conditioner operation.
- (2) Press the master control button and the fan control button simultaneously for 2 seconds or more to start the test run.

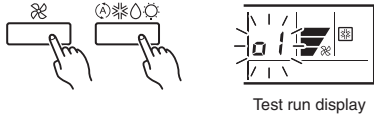

- (3) Press the start/stop button to stop the test run.

[SELF-DIAGNOSIS]

When the error indication E:EE is displayed, follow the following items to perform the self-diagnosis. E:EE indicates an error has occurred.

REMOTE CONTROLLER DISPLAY

- 1) Stop the air conditioner operation.
- 2) Press the set temperature buttons \wedge / \vee simultaneously for 5 seconds or more to start the self-diagnosis.
Refer to the following tables for the description of each error code.

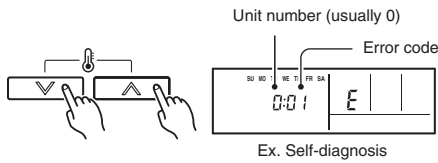

- (3) Press the set temperature buttons \wedge / \vee simultaneously for 5 seconds or more to stop the self-diagnosis.

Error code	Error contents
00	Communication error (indoor unit ↔ remote controller)
01	Communication error (indoor unit ↔ outdoor unit)
02	Room temperature sensor open
03	Room temperature sensor short-circuited
04	Indoor heat exchanger temperature sensor open
05	Indoor heat exchanger temperature sensor short-circuited
06	Outdoor heat exchanger temperature sensor
08	Power source connection error
09	Float switch operated
0A	Outdoor temperature sensor
0c	Discharge pipe temperature sensor
0E	Outdoor high pressure abnormal
11	Model abnormal
12	Indoor fan abnormal
13	Outdoor signal abnormal
14	Outdoor EEPROM abnormal
15	Compressor temperature sensor
16	Pressure switch error
17	IPM error
18	CT error
19	Active filter module (AFM) error

Error code	Error contents
1A	Compressor does not operate
1b	Outdoor unit fan error
1c	Communication error (inverter → multicontroller)
1d	2 way valve sensor error
1E	Expansion valve error
1F	Connection indoor unit error

OUTDOOR UNIT

- (1) Is there any abnormal noise and vibration during operation?
- (2) Will noise, wind or drain water from the unit disturb the neighbours?
- (3) Is there any gas leakage?

- Do not operate the air conditioner in the test running state for a long time.

OUTDOOR UNIT

Error contents	LED (RED)
Serial signal error	1 time blink
Discharge pipe thermistor error	2 times blink
Heat exchanger thermistor error	3 times blink
Outdoor temperature thermistor error	4 times blink
2 - way valve thermistor A, B error	5 times blink
3 - way valve thermistor A, B error	6 times blink
Compressor thermistor error	7 times blink
Pressure switch error	8 times blink
Indoor unit communication error	9 times blink
Current trip error	10 times blink
CT error	11 times blink
Compressor position detection error	12 times blink
Compressor starting error	13 times blink
Timer error	14 times blink

INDOOR PRINTED CIRCUIT BOARD CIRCUIT DIAGRAM

Model : RC-18LA

CON TROLLER PCB ASSEMBLY (MAIN PCB)
K01AL-040HSE-C1

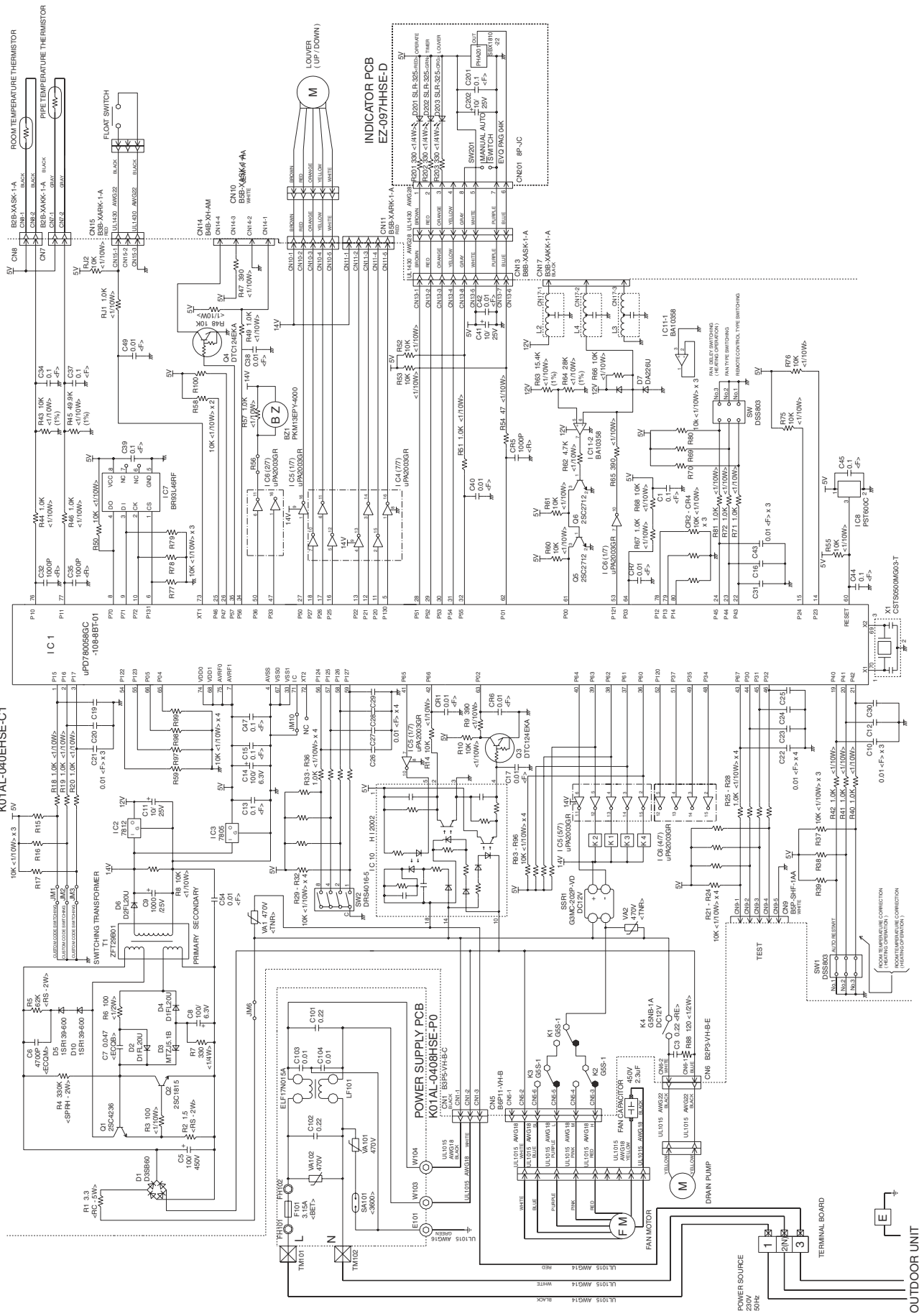

Model : RC-24LA

CONTROLLER PCBASSEMBLY (MAIN PCB)
K01AL-0415HSE-C1

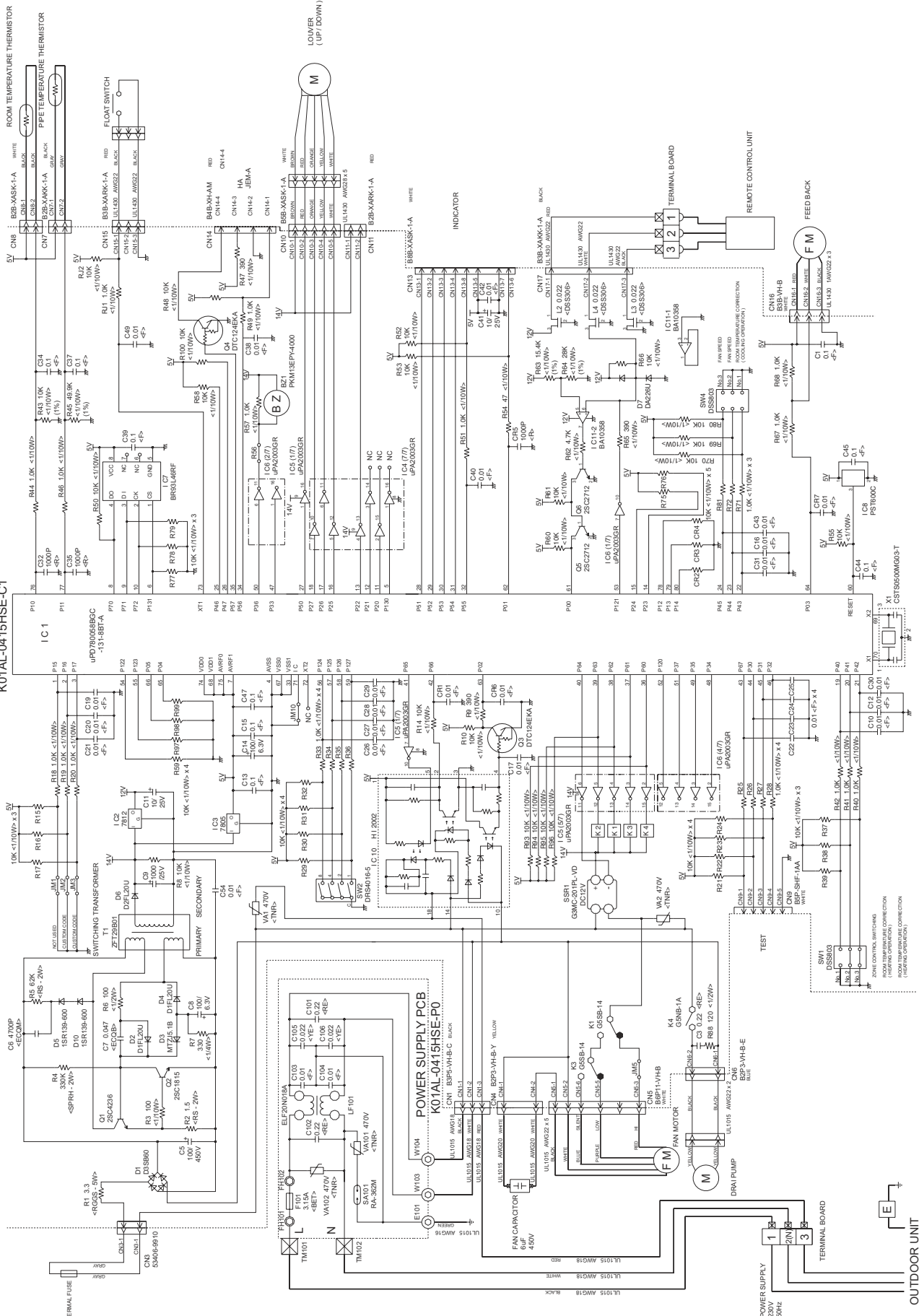

OUTDOOR UNIT

OUTDOOR PRINTED CIRCUIT BOARD CIRCUIT DIAGRAM

**Models : ROT-18LA
ROT-24LA**

CONTROLLER PCB ASSEMBLY
 ROT-18LA : K03AV-0401HUE-C1
 ROT-24LA : K03AV-0402HUE-C1

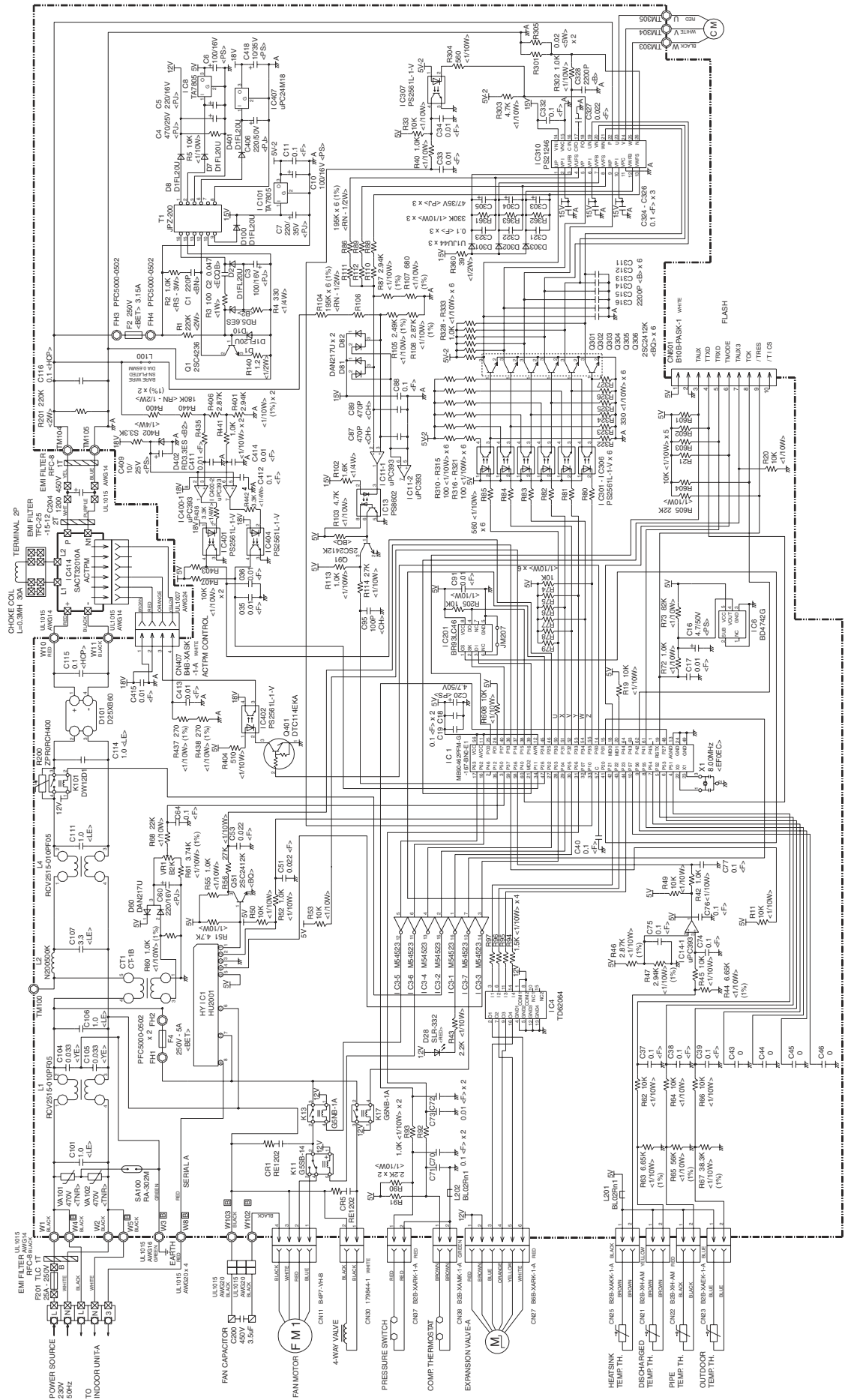

DISASSEMBLY ILLUSTRATION

Model : RC-18LA

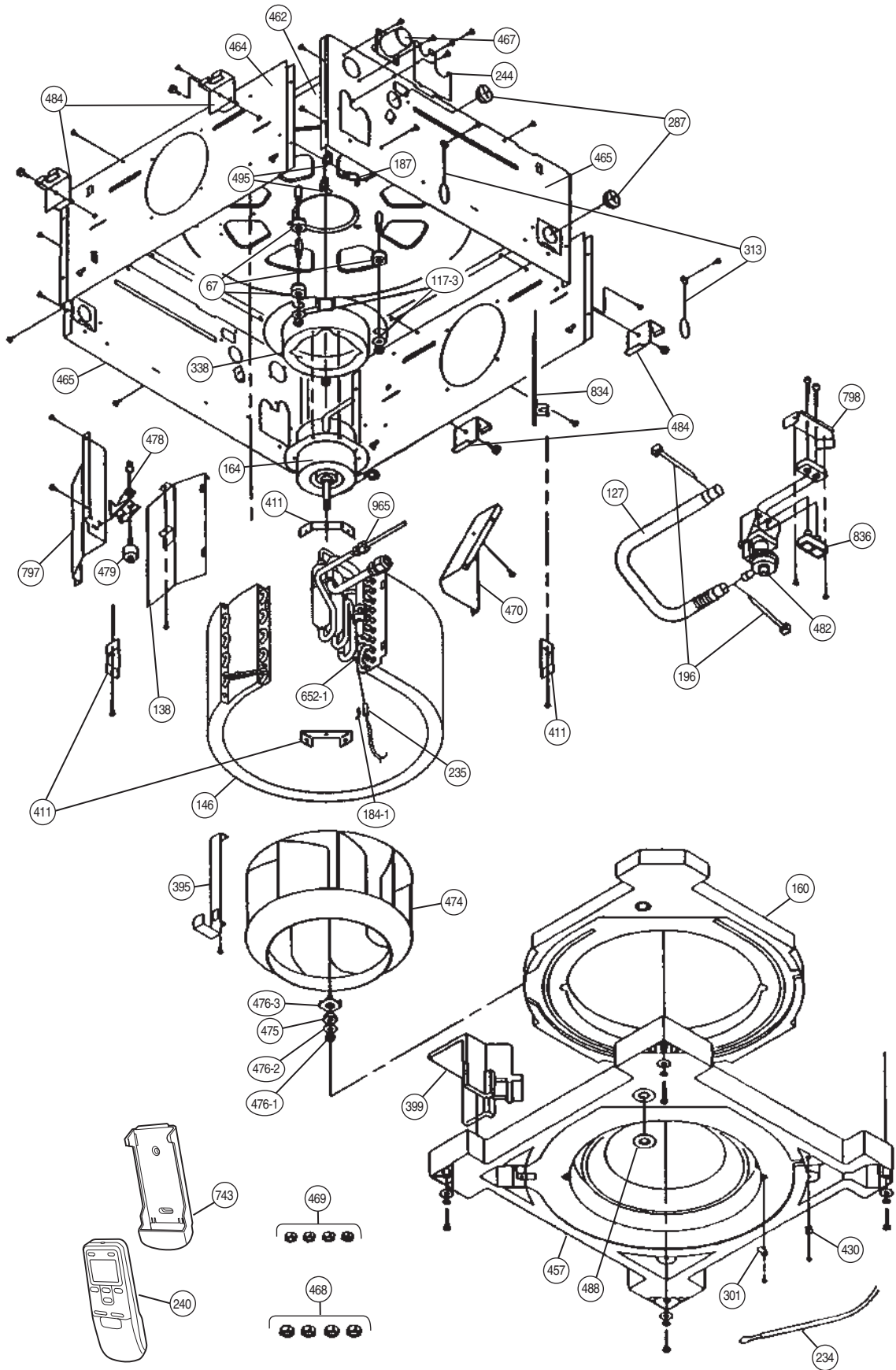

Model : RC-18LA

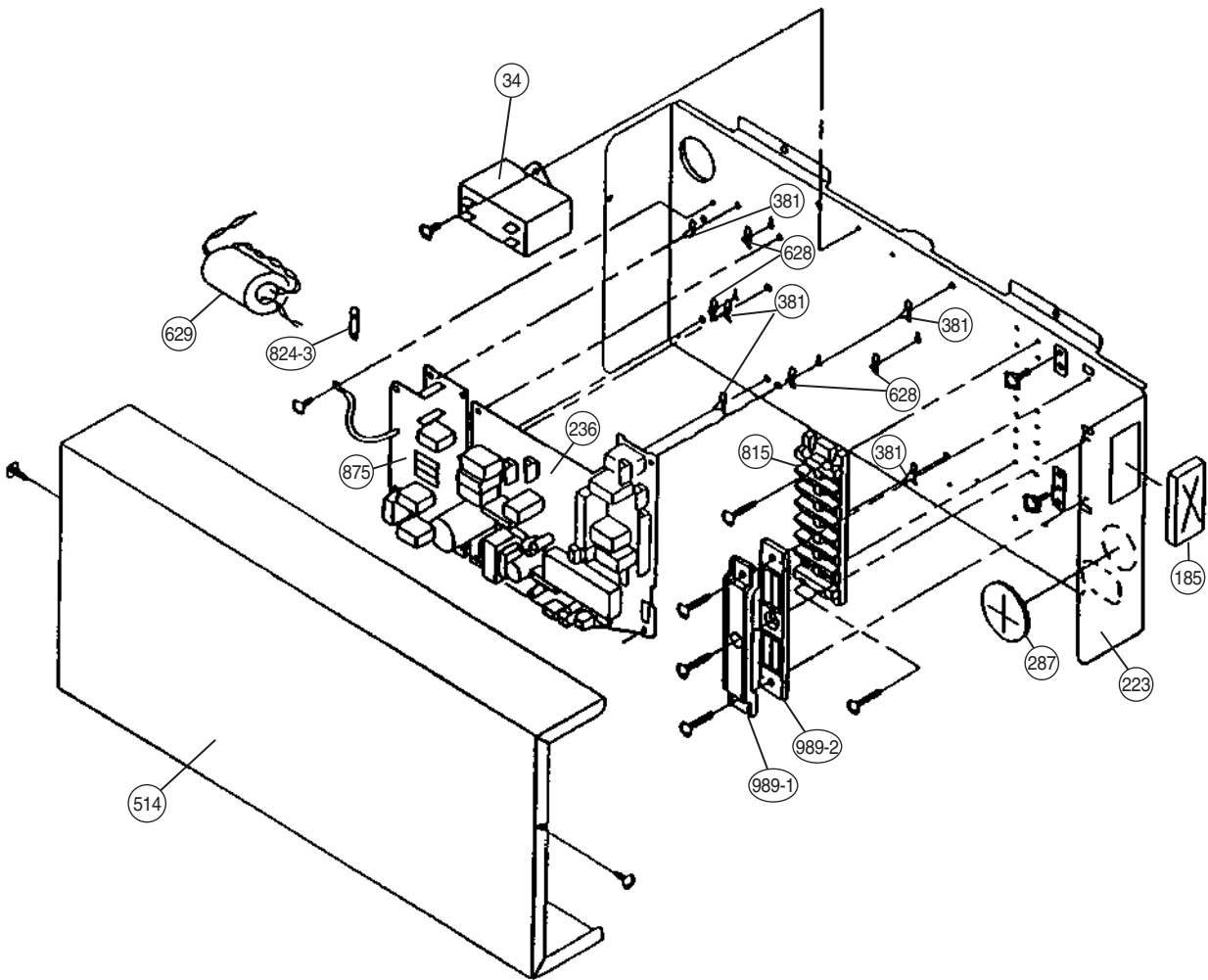

Model : UTG-UDFB-W

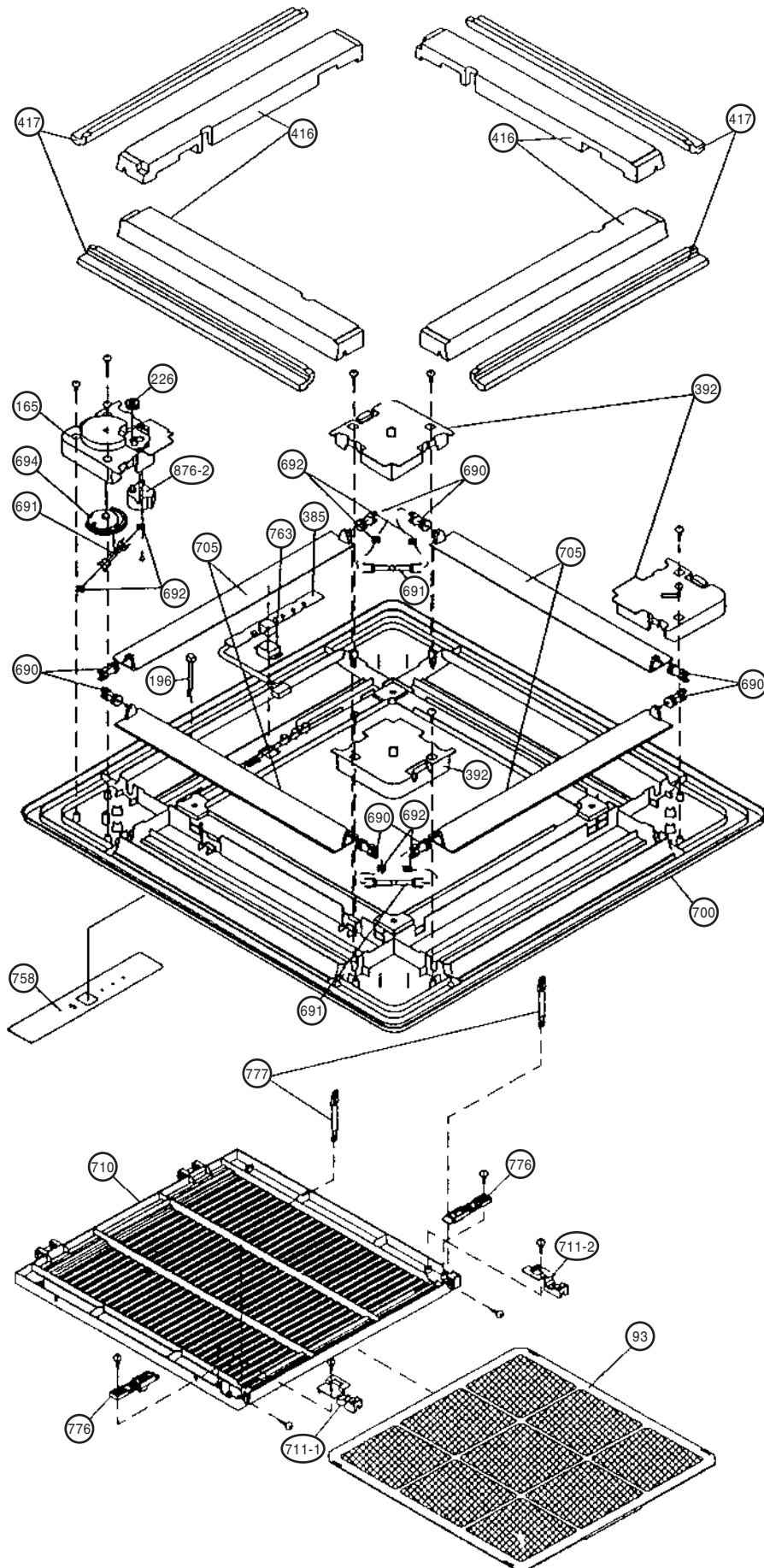

Model : RC-24LA

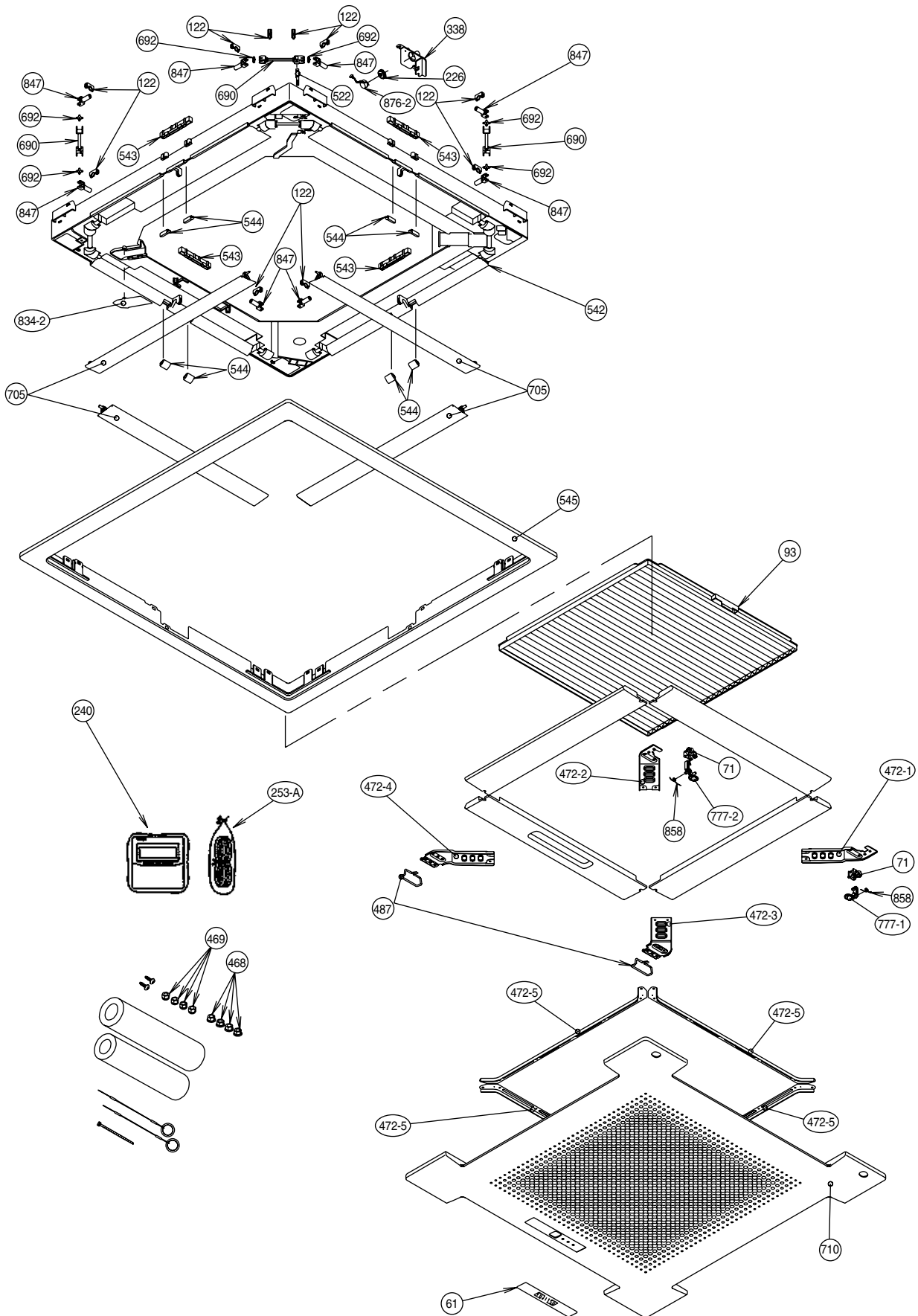

Model : RC-24LA

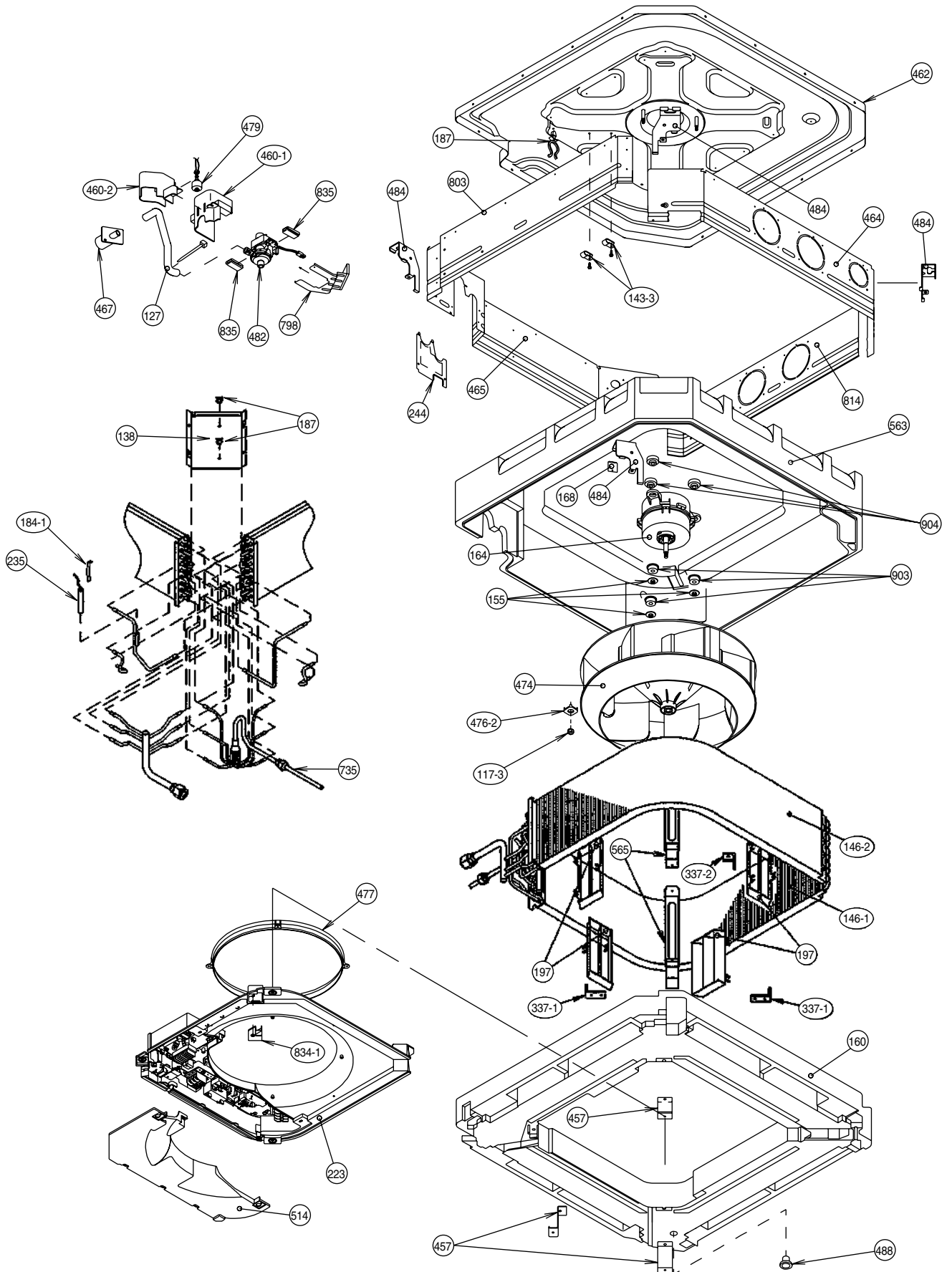

Model : RC-24LA

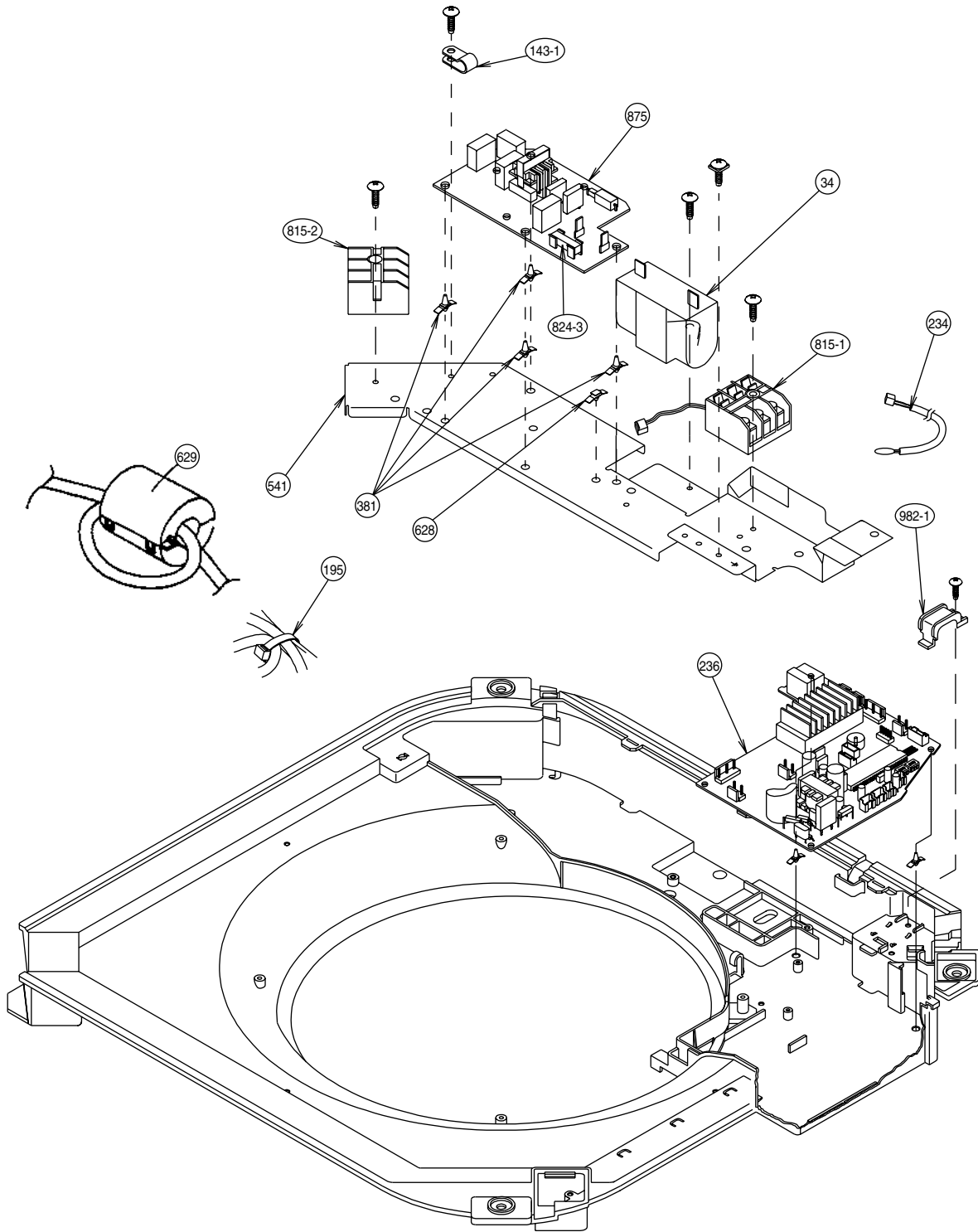

Models : ROT-18LA
ROT-24LA

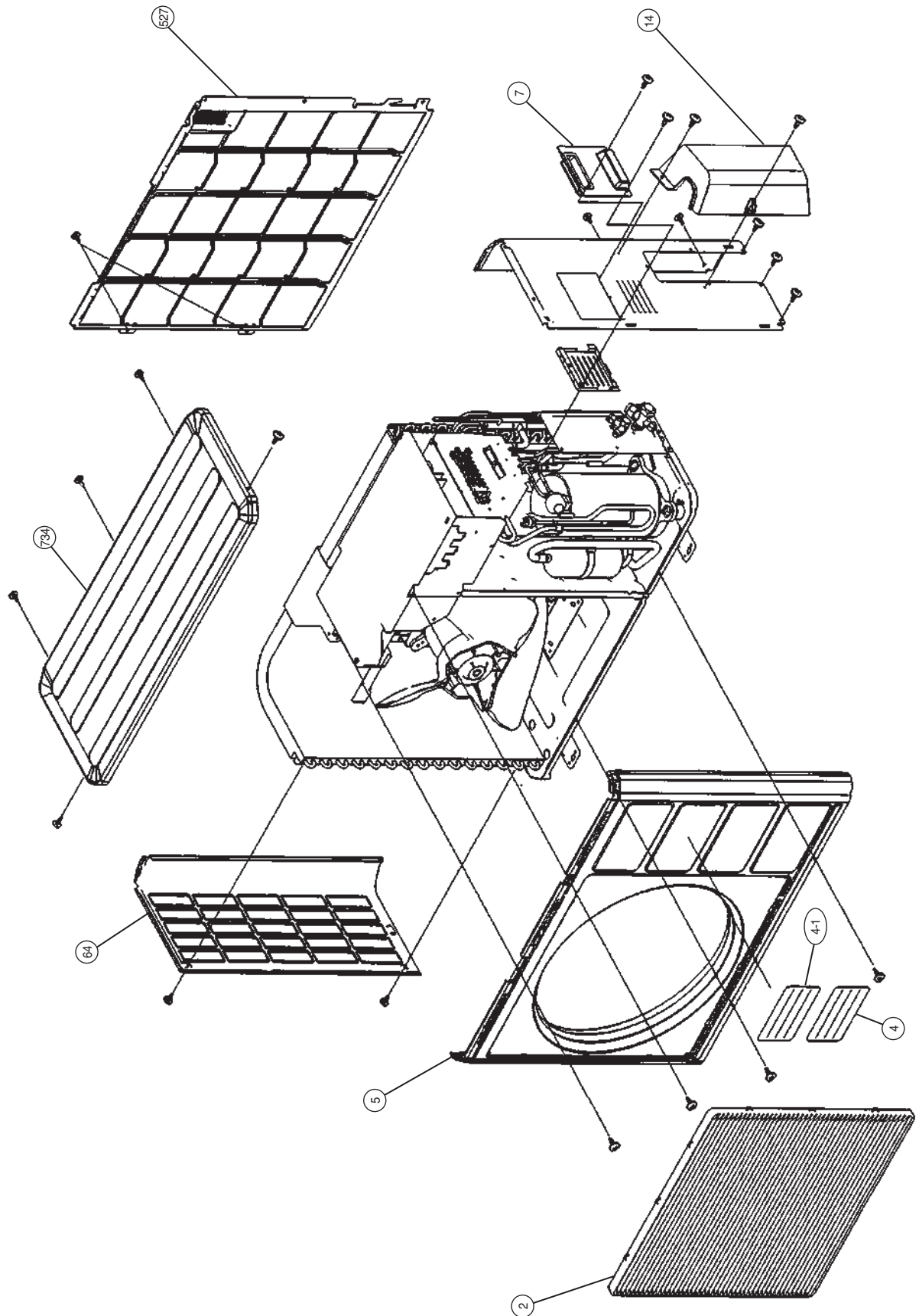

**Models : ROT-18LA
ROT-24LA**

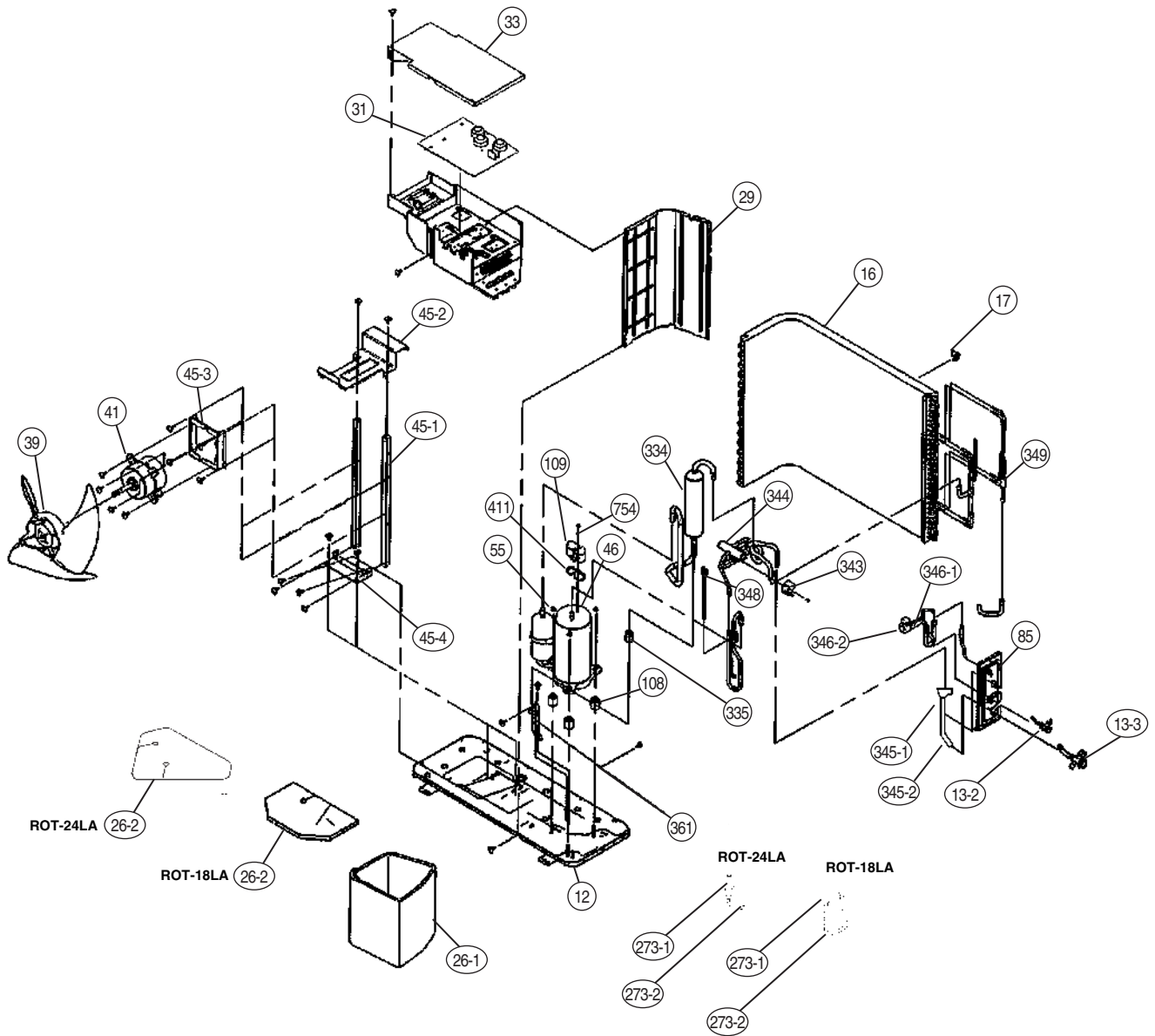

PARTS LIST

When you order parts, please make a photocopy of this page
and fill the number of the parts in the "Order" column.

INDOOR UNIT

Ref. No.	Description	Part No.	Ord. Q'ty	Ref. No.	Description	Part No.	Ord. Q'ty
		RC-18LA				RC-18LA	
34	Capacitor, Plastic	9703306044		467	Drain Port	313005415658	
67	Rubber	9361279001		468	Special Nut-A (Large)	313005446653	
117-3	Special Washer M6	313306391007		469	Special Nut-B (Small)	313005446759	
127	Drain Hose	9359659013		470	Separate Wall-B	9359648000	
138	Separate Wall-A	9359647003		474	Turbo Fan	9359658009	
146	Evaporator Assy-IN	9373214014		475	Turbo Fan Rubber	9366013006	
160	Drain Pan	9359651000		476-1	Special Nut M8	313005360755	
164	Fan Motor Assy-IN	9601040057		476-2	Special Washer	301801185049	
184-1	Thermistor Spring-A	313728262708		476-3	Special Washer	9359954002	
185	Rubber Bushing	313005066051		478	Senser-M. Bracket	9359654001	
187	Clamp No. 1219	313361271706		479	Float Switch	313005416154	
196	Clamp SKB-150	313035356905		482	Pump Unit	9359974000	
223	Control Box	9359661016		484	Hanger Metal	9359644002	
234	Room Temperature Thermistor	9703299032		488	Drain Pan Plug	9359653004	
235	Pipe Temperature Thermistor	9703297014		495	Clamp Nu. 2U46	9352715006	
236	Controller PCB Assy	9704557797		514	Control Box Cover	9359662006	
240	Remote Control Unit	9371190037		628	Locink Spacer -B	313005446558	
244	Pipe Cover	9359646006		629	EMI Filter	0400197119	
287	Power Cap	9352173011		652-1	Thermistor Holder Pipe	313806262805	
301	Clamp NK-2N	313985355201		743	Remotre Control Unit Holder Case	9305642014	
313	Hooking Wire	9359983002		797	Separate Wall-C	9359649007	
338	Motor Fixture	9359656005		798	Pump Hook Bracket	9359650003	
381	Locking Spacer	313209391506		815	Terminal-3P	9900203016	
395	Supporter (Eva.)	9373179016		824-3	Fuse	0600222512	
399	Air Duct	9359660002		834	Wire Cover	9359878001	
411	Supporter-A	9359655008		836	Cushion-B (For Pump)	9356084016	
430	Clamp NK-7N	313095365602		875	Power Supply PCB Assy	9704561213	
457	Drain Pan Supporter	9359652007		965	Flare Nut-B	9351062019	
462	Top Cover Plate	9359642015		989-1	Cord Clamp-A	9359822011	
464	Body-A	9359643005		989-2	Cord Clamp-B	9359823018	
465	Body-B	9359645009					

Grille Assy (UTG-UDFB-W)

Ref. No.	Description	Part No.	Ord. Q'ty	Ref. No.	Description	Part No.	Ord. Q'ty
93	Filter	9359632009		700	Panel	9359619017	
165	Motor Cover	9359623014		705	Louver	9359624011	
196	Clamp SKB-150	313035356905		710	Intake Grille	9360543011	
226	Motor Gear	9359629009		711-1	Filter Clamp-A	9359634003	
385	Indicator PCB Assy	9702224011		711-2	Filter Clamp-B	9359635000	
392	Cover-A	9359622017		758	Decoration Plate (UTG-UDFA-W)	9360862013	
416	Insulation (Panel)-A	9359620006		763	Receiver Cover	9359630005	
417	Insulation (Panel)-B	9359621003		776	Grille Stopper	9359633013	
690	Joint-A	9359626008		777	Grille Hook	9359761006	
691	Joint-B	9359627005					
692	Joint Shaft	9359625001		876-2	Step Motor-V	9360307019	
694	Cam Gear	9359628002		—	Intake Grille Sub Assy	9360031020	

When you order parts, please make a photocopy of this page and fill the number of the parts in the "Order" column.

INDOOR UNIT

Ref. No.	Description	Part No.	Ord. Q'ty	Ref. No.	Description	Part No.	Ord. Q'ty
		RC-24LA				RC-24LA	
34	Capacitor, Plastic	9900270216		472-4	Grille Reinforcement-D	9362741002	
61	Decoration Plate	9363133004		472-5	Grille Reinforcement-E	9362742009	
71	Grille Hook Holder	9362782005		474	Tube Fan Assy	9362810012	
93	Filter	9362766005		476-2	Special Washer	9362756006	
117-3	Hex. Nut w/Spring Washer	301721180114		477	Bellmouth (B)	9362774000	
122	Louver Support Holder	9362799003		479	Float Switch	9703285004	
127	Drain Hose	9365074008		482	Pump Unit	9703125010	
138	Separate Wall	9362793001		484	Hook	9362736008	
143-1	Clamp NK-3N	313361274700		487	Grille Hinge Wire	9362754002	
143-3	Clamp NK-9N	313209399700		488	Drain Pan Plug	313005174654	
146-1	Evaporator-A Assy	9373799030		514	Control Box Cover	9362763004	
146-2	Evaporator-B Assy	9373800033		522	Joint Gear	9362772006	
155	Special Nut M6	9307615016		541	Terminal Plate	9363642001	
160	Drain Pan Assy	9362804004		542	Panel Base	9362759014	
164	Fan Motor Assy-IN	9601558019		543	Panel Frame Holder	9362761017	
168	Cabinet-E	9362735001		544	Panel Base Holder	9362760010	
184-1	Thermistor Spring-A	313728262708		545	Panel Frame	9362758017	
187	Clamp No. 1219	313361271706		563	Insulation (Inner Box)	9362797009	
195	Clamp SKB-100	313361275805		565	Evaporator Holder Assy	9362802024	
197	Wind Guide Board	9373444015		628	Locking Spacer-B	313005446558	
223	Control Box	9362762007		629	EMI Filter	0400247074	
226	Motor Gear	9362764001		690	Joint-A	9362773003	
234	Room Temperature Thermistor	9703299025		692	Joint Shaft	9362771009	
235	Pipe Temperature Thermistor	9703297014		705	Louver	9362769013	
236	Controller PCB Assy	9705914025		710	Intake Grille	9362854016	
240	Remote Control Unit	9372266052		735	Distributor Assy	9371325040	
244	Pipe Cover	9362748001		777-1	Grille Hook-A	9362779012	
253-A	Wire Assy (Remote)	9372714010		777-2	Grille Hook-B	9362778015	
337-1	Reinforcement (Eva.)-A	9362749008		798	Pump Hook Bracket	9362753005	
337-2	Reinforcement (Eva.)-B	9362750004		803	Cabinet-D	9362792004	
338	Motor Holder	9362765008		814	Cabinet-C	9362791007	
381	Locking Spacer	313209391506		815-1	Terminal-3P	9306489069	
457	Reinforcement (Drain Pan)	9362757003		815-2	Terminal-3P	9703345012	
460-1	Pump Cover-A	9362775007		824-3	Fuse	0600222512	
460-2	Pump Cover-B	9362776004		834-1	Wire Cover-A	9362789004	
462	TOP Cover Plate Assy	9362806022		834-2	Wire Cover-B	9362788007	
464	Cabinet-A Assy	9362807012		835	Cushion Rubber (Pump)	9362777001	
465	Cabinet-B Assy	9362808019		847	Louver Supporter	9362770019	
467	Drain Port	9362786003		858	Grille Spring	9362755009	
468	Special Nut-A (Large)	313005446653		875	Power Supply PCB Assy	9704561244	
469	Special Nut-B (Small)	313005446759		876-2	Step Motor	9360307019	
472-1	Grille Reinforcement-A	9362738002		903	Rubber (Vibration-proof)-A	9364891002	
472-2	Grille Reinforcement-B	9362739009		904	Rubber (Vibration-proof)-B	9364892009	
472-3	Grille Reinforcement-C	9362740005		982-1	Cord Clamp	9356857009	

When you order parts, please make a photocopy of this page and fill the number of the parts in the "Order" column.





OUTDOOR UNIT

Ref. No.	Description	Part No.		Ord. Q'ty	Ref. No.	Description	Part No.		Ord. Q'ty
		ROT-18LA	ROT-24LA				ROT-18LA	ROT-24LA	
3	Fan Guard	9371187013	9371187013		69-3	Hex. Bolt Socket	301210060360	301210060360	
5	Front Panel, Painted	9371924014	9371924014		85	Valve Plate, Painted	9371928036	9371928036	
7	Connector Cover (Cabinet)	9366398004	9366398004		108	Rubber Seat (For Comp.)	9358080009	9358080009	
12	Base Assy, Painted	9371920078	9371920078		109	Terminal Cover (For Comp.)	9373264019	9373264019	
13-2	2-Way Valve	9372204054	9372204023		187	Clip (Cable)	9352715006	9352715006	
13-3	3-Way Valve	9372205051	9372205075		199	BR Sheet	9363708042	9363708042	
14	Valve Cover	9372796016	9372796016		218-3	Relay	9900117016	9900117016	
15	Condenser Sub Assy	9372313183	9372313183		273-1	Strainer Assy	9372524015	9372524015	
16	Condenser Assy	9372181096	9372181096		273-2	Joint Pipe (2-Way)-A	9373729549	9373729495	
17	Thermistor Holder Pipe	313714262805	313714262805		334	Accumulator	9368391003	9368391003	
26-1	Compressor Cover-A	9373730019	9374430055		335	Accumulator Holder Rubber	9354022010	9354022010	
26-2	Compressor Cover-B	9373730026	9374431052		343	Solenoid	9900165079	9900165079	
29	Separate Wall	9372795019	9372795019		344	4-Way Valve	9900163013	9900163013	
31	Controller PCB Assy	9705285033	9705285033		345-1	Muffler	9372369029	9372369029	
—	ACTPM	9703457012	9703457012		345-2	Joint Pipe (3-Way)	9373729556	9373729501	
—	Capacitor, Elec.	9705387010	9705387010		346-1	Expansion Valve Assy	9373729518	9373729518	
33	Control Cover	9372792018	9372792018		346-2	Coil (Expansion Valve)	9900057022	9900057022	
—	Fuse	0600086039	0600086039		348	Pressure Switch Assy	9373729044	9373729044	
—	Fuse Holder	0501454012	0501454012		349	Capillary Assy	9373729433	9373729433	
34	Capacitor, Plastic	9704305077	9704305077		361	Accumulator Support Assy	9372252017	9372252017	
—	Terminal-5P	9900203023	9900203023		411	Gasket	9373266013	9373266013	
—	Terminal-2P	9701971015	9701971015		527	Protective Net	9371934013	9371934013	
39	Propeller Fan Assy	9366378013	9366378013		734	Top Plate	9371925011	9371925011	
41	Fan Motor Assy-IN	9601671046	9601671046		754	Rubber Washer	9358078006	9358078006	
45-1	Motor Bracket	9371929019	9371929019		—	Compressor Pressure Switch	9900186012	9900186012	
45-2	Motor Bracket-Top	9371931012	9371931012		—	Compressor Thermal Switch	9373263012	9373263012	
45-3	Motor Bracket-Center	9371930015	9371930015		—	Discharge Temperature Thermistor	9704219039	9704219039	
45-4	Motor Bracket-Bottom	9371932019	9371932019		—	Heat Exchanger Thermistor	9704220059	9704220059	
46	Compressor Assy	9373262015	9373262015		—	Outdoor Temperature Thermistor	9703516047	9703516047	
55	Special Nut M8	9355091008	9355091008		—	Heat Sink Thermistor	9900195014	9900195014	
64	Side Panel-L, Painted	9371926018	9371926018						

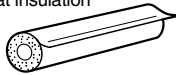

STANDARD ACCESSORIES

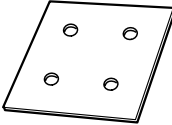
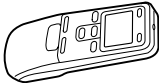
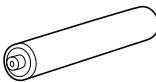
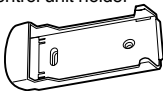
Models : RC-18LA / ROT-18LA

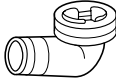

INDOOR UNIT ACCESSORIES

Name and Shape	Application	Part No.
Coupler heat insulation 	For indoor side pipe joint	9350716029
		9352766015
Special nut A (large flange) 	For installing indoor unit	313005446653
Special nut B (small flange) 	For installing indoor unit	313005446759
Template 	For ceiling hole cutting	9360256003
Remote control unit 	Use for air conditioner operation	9371190037
Battery (penlight) 	For remote control unit	0600185534
Remote control unit holder 	For mounting the remote control unit	9305642014
Tapping screw (φ3 x 12) 	For remote control unit holder installation	301141533125

OUTDOOR UNIT ACCESSORIES



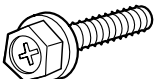





Name and Shape	Application	Part No.
Drain Pipe 	For outdoor unit drain piping work [Heat & Cool (Reverse cycle) model only]	9303029015
Drain Cap 		313166024302

GRILLE ASSY ACCESSORIES



Name and Shape	Application	Part No.
Bolt 	For opening the refrigerant valve on the outdoor unit	0700139116
Washer 	For mounting grille	301801155020
Blower cover insulation 	For discharged air	9360047007

Models : RC-24LA / ROT-24LA

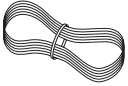
INDOOR UNIT ACCESSORIES

Name and Shape	Part No.
Coupler heat insulation 	9350716029 } 1 each 9352766015 }
Binder 	313361275805 (Small)
Screw 	0700181108 For installing the remote controller
Special nut A (large flange) 	313005446653
Special nut B (small flange) 	313005446759
Remote control unit 	(Cooling & Heating model) 9372266052
Template 	9363173000
Blower cover insulation 	9363265002
Hook wire 	9363168006
Remote controller cord 	9372714010

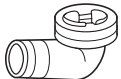
OUTDOOR UNIT ACCESSORIES

Name and Shape	Application	Part No.
Drain Pipe 	For outdoor unit drain piping work [Heat & Cool (Reverse cycle) model only]	9303029015
Drain Cap 		313166024302



MANUFACTURER :

Fuji Denki Sosetsu Co., Ltd.

Tokyo, Japan