

INVERTER SPLIT TYPE
AIR CONDITIONER (50Hz)
CASSETTE TYPE

SERVICE MANUAL



Indoor unit	Outdoor unit
AUYG24LVLA	AOYG24LALA

CONTENTS

SPECIFICATIONS.....	1
DIMENSIONS.....	2
REFRIGERANT SYSTEM DIAGRAM ...	3
CIRCUIT DIAGRAM.....	4
INDOOR PCB CIRCUIT DIAGRAM....	5
OUTDOOR PCB CIRCUIT DIAGRAM...	8
ERROR DETECTION.....	10
PARTS (DECORATION PANEL).....	13
PARTS (INDOOR UNIT).....	15
PARTS (OUTDOOR UNIT).....	18
ACCESSORIES.....	20

SPECIFICATIONS

ELECTRICAL DATA

TYPE		Inverter cool & heat
INDOOR UNIT		AUYG24LVLA
OUTDOOR UNIT		AOYG24LALA
COOLING CAPACITY		6.80 kW
HEATING CAPACITY		8.00 kW
POWER SOURCE		230 V
FREQUENCY		50 Hz
RUNNING CURRENT	Cooling	9.7 A
	Heating	9.9 A
INPUT WATTS	Cooling	2.21 kW
	Heating	2.26 kW
E.E.R.	Cooling	3.08 kW/kW
COP	Heating	3.54 kW/kW
AIR FLOW, INDOOR UNIT		930 m ³ /h
AIR FLOW, OUTDOOR UNIT		2,470 m ³ /h
MOISTURE REMOVAL		2.7 L/hr
MAXIMUM CURRENT	Cooling	12.0 A
	Heating	13.5 A

FAN SPEED

INDOOR UNIT	Discrimination	MFF-24RVL
	High	960 r.p.m.
	Medium	850 r.p.m.
	Low	650 r.p.m.
	Quiet	500 r.p.m.
OUTDOOR UNIT	Discrimination	MFE-24ROAM
	Cooling	1,050 r.p.m.
	Heating	1,050 r.p.m.

DECORATION PANEL

MODEL NAME		UTG-UFYD-W
DIMENSIONS	H x W x D	49 x 700 x 700 mm
WEIGHT	Net / Shipping	2.6 kg / 4.5 kg

NOISE LEVEL

INDOOR UNIT Cooling	High	49 dB
	Medium	44 dB
	Low	36 dB
	Quiet	30 dB
INDOOR UNIT Heating	High	49 dB
	Medium	45 dB
	Low	40 dB
	Quiet	33 dB
OUTDOOR UNIT	Cooling	52 dB
	Heating	53 dB

COMPRESSOR AND REFRIGERANT

TYPE		Hermetic type, 4 poles	
DISCRIMINATION		DA150A1F-20NA	
COMPRESSOR WEIGHT (with oil)		10.0 kg	
PRECHARGED REFRIGERANT		1,700 g	
REFRIGERANT TYPE		R410A	
FULL CHARGE	Pipe length	15 m	1,700 g
		20 m	1,800 g
		25 m	1,900 g
		30 m	2,000 g
ADDITIONAL CHARGE		20 g/m	
MAXIMUM PIPE HEIGHT		20 m	

DIMENSIONS

INDOOR UNIT	H x W x D	245 x 570 x 570 mm
OUTDOOR UNIT	H x W x D	570 x 790 x 315 mm

WEIGHT

INDOOR UNIT	Net / Shipping	16 kg / 19 kg
OUTDOOR UNIT	Net / Shipping	44 kg / 48 kg

DIMENSIONS

Unit : mm

DECORATION
PANEL

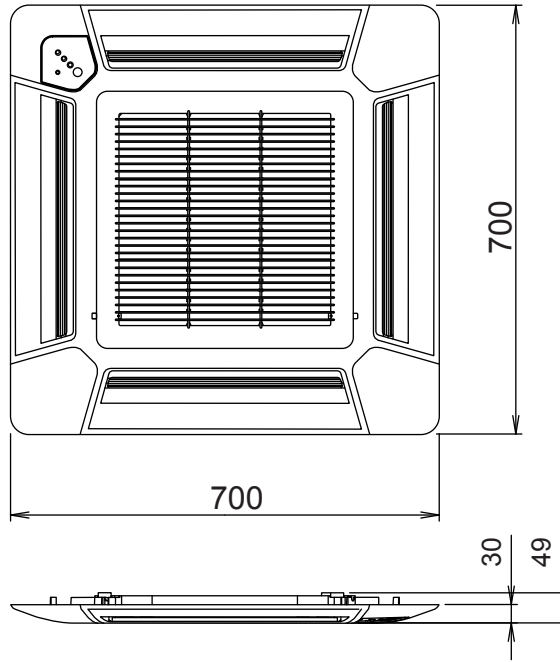

INDOOR
UNIT

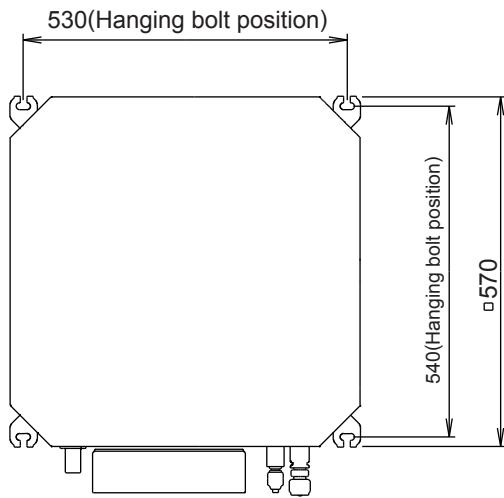

Top view

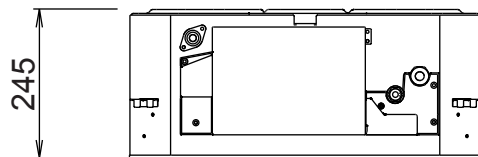

Side view

OUTDOOR UNIT

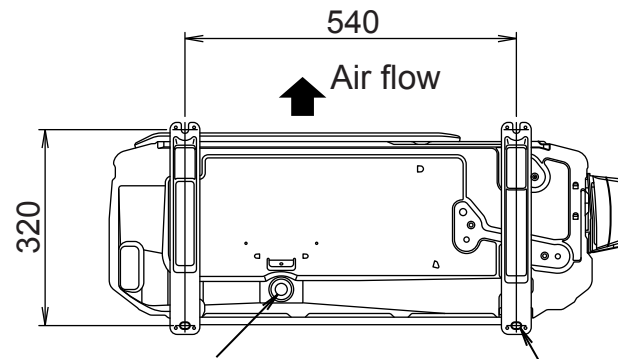
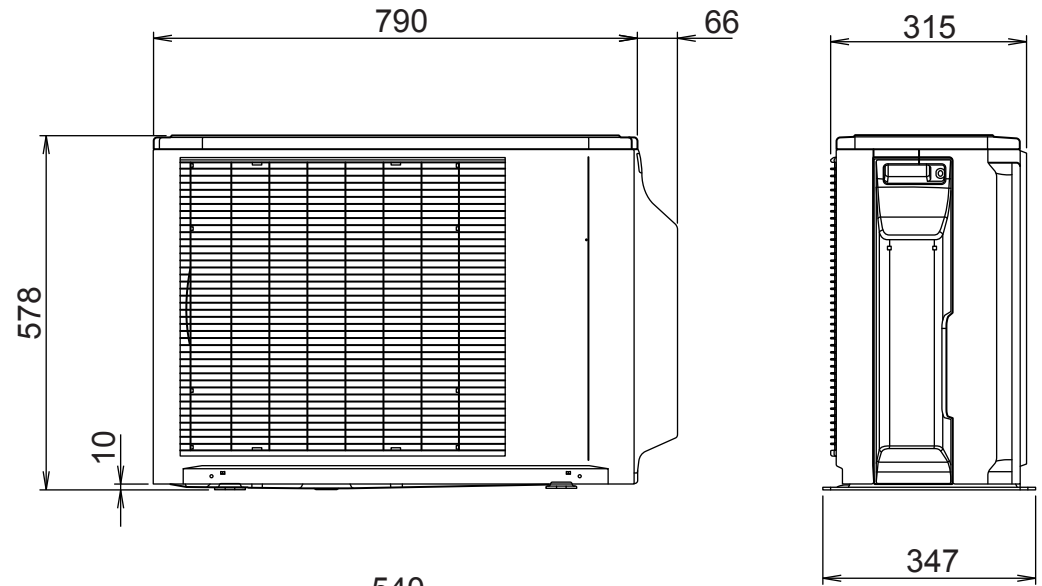
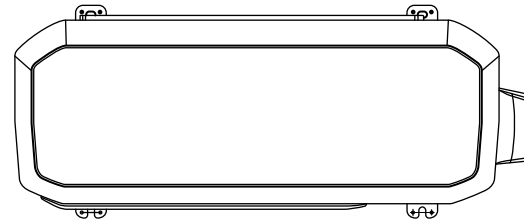

Drain pipe
mounting place
(ϕ 20)

4- ϕ 10mm hole

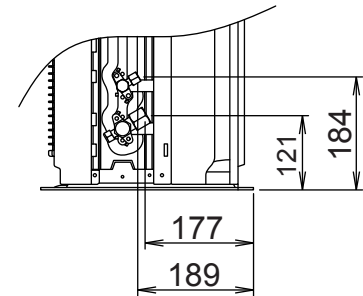

REFRIGERANT SYSTEM DIAGRAM

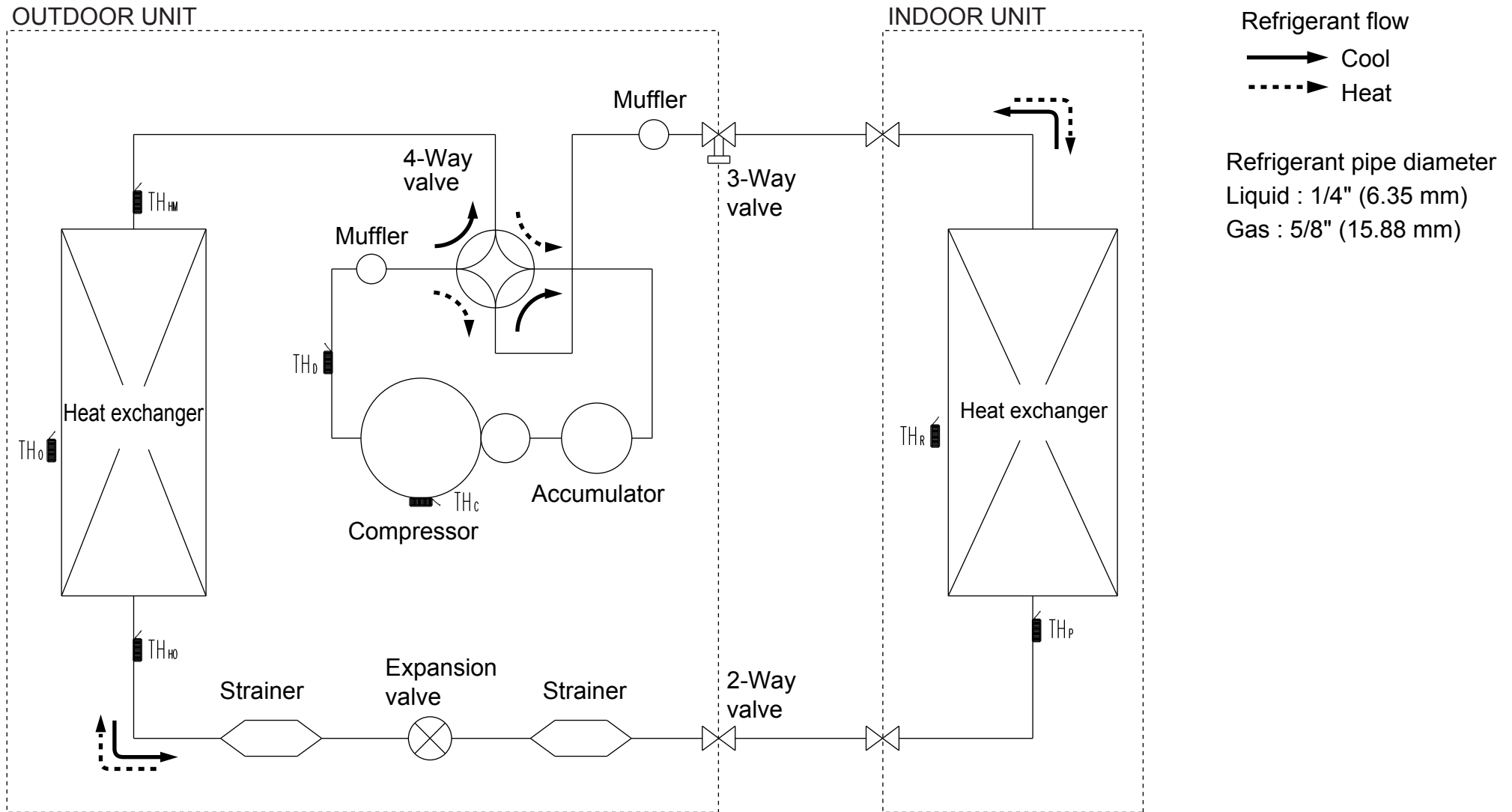

TH_c : THERMISTOR (COMPRESSOR TEP.)
 TH_d : THERMISTOR (DISCHARGE TEP.)
 TH_{HM} : THERMISTOR (HEAT EXCHANGER MED TEP.)
 TH_{HO} : THERMISTOR (HEAT EXCHANGER OUT TEP.)
 TH_o : THERMISTOR (OUTDOOR TEP.)

TH_p : THERMISTOR (PIPE TEP.)
 TH_R : THERMISTOR (ROOM TEP.)

CIRCUIT DIAGRAM

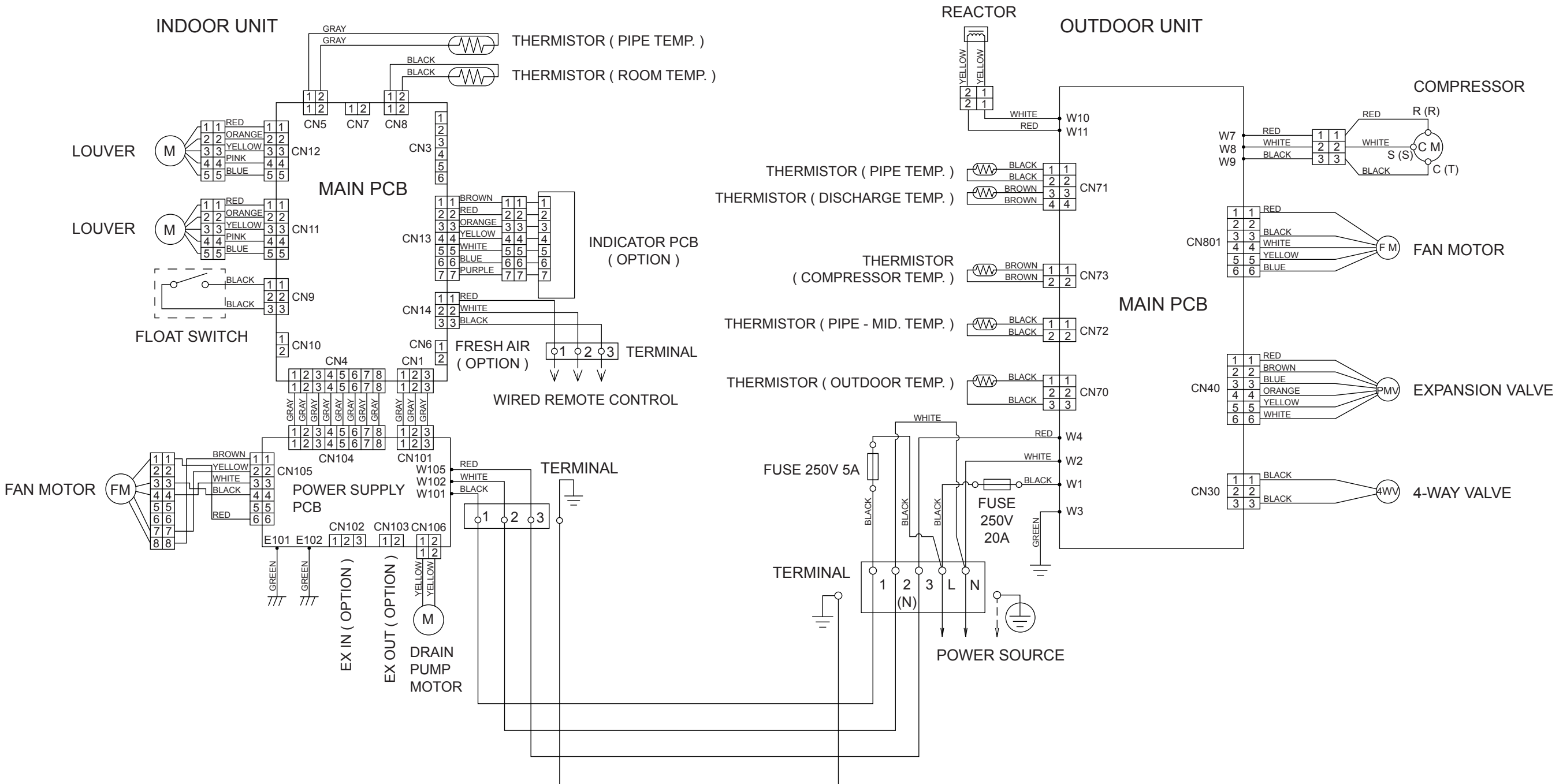

INDOOR PCB CIRCUIT DIAGRAM

CONTROL UNIT
EZ-0122MHSE

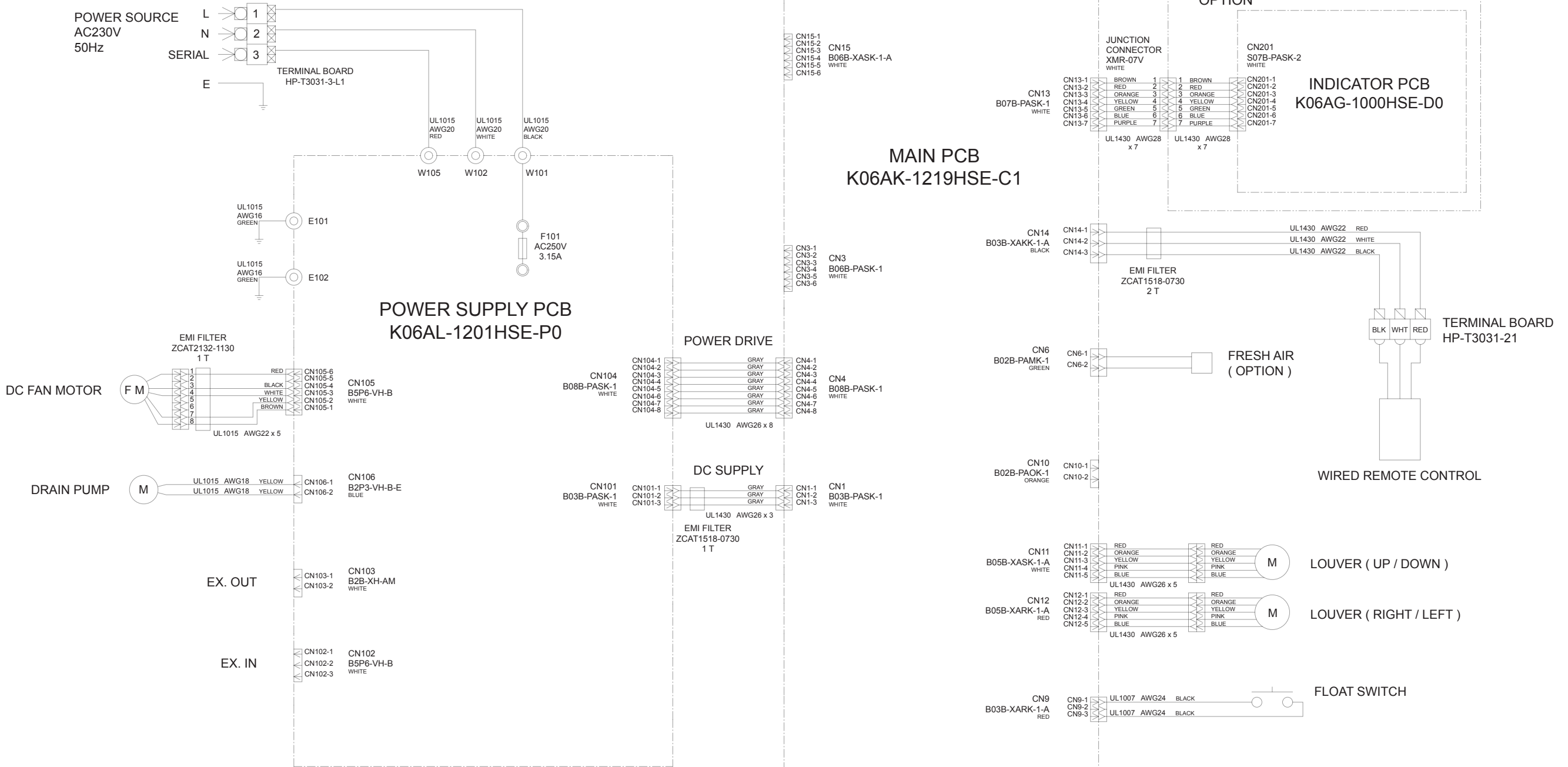

INDOOR UNIT
MAIN PCB
K06AK-1219HSE-C1

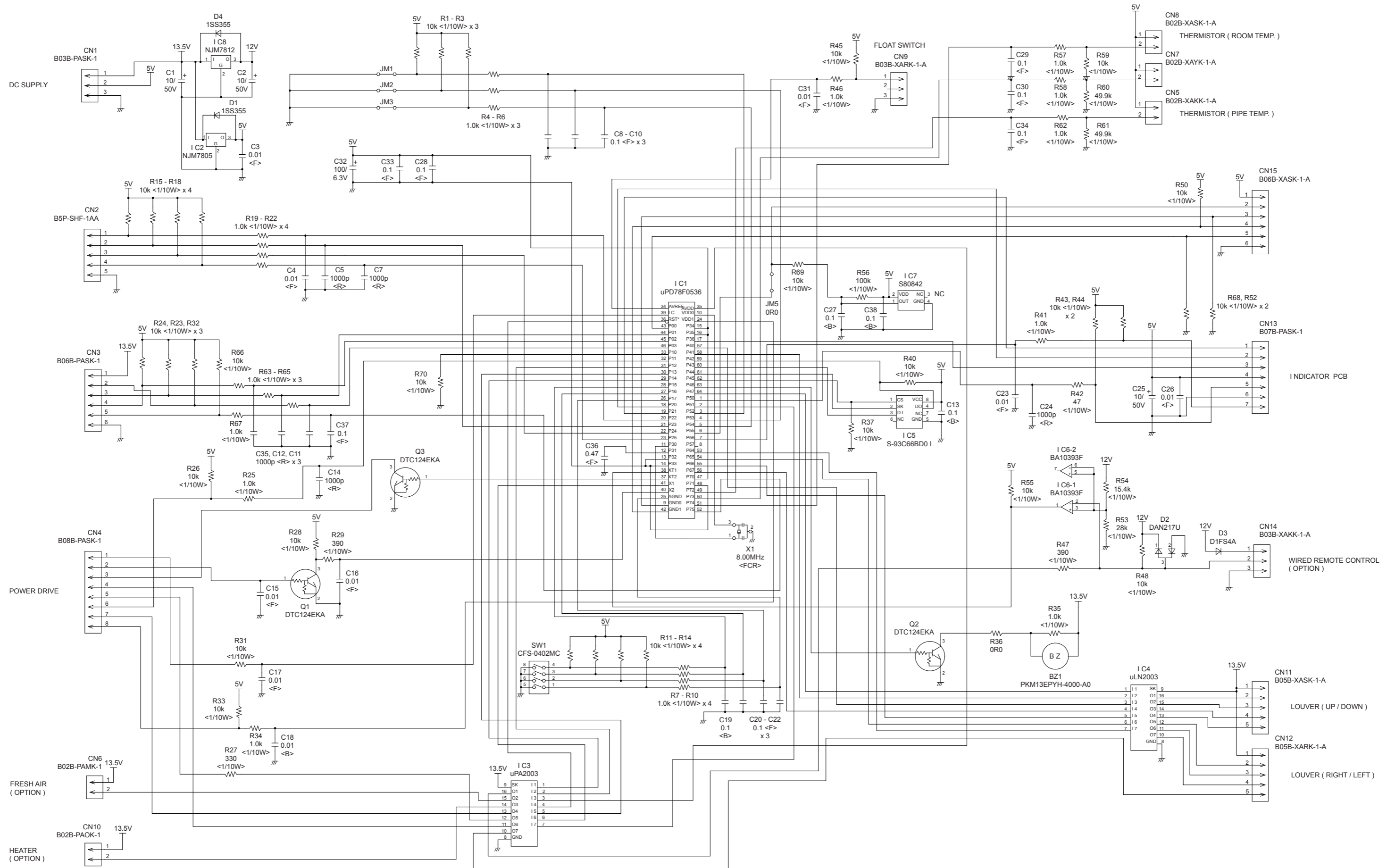

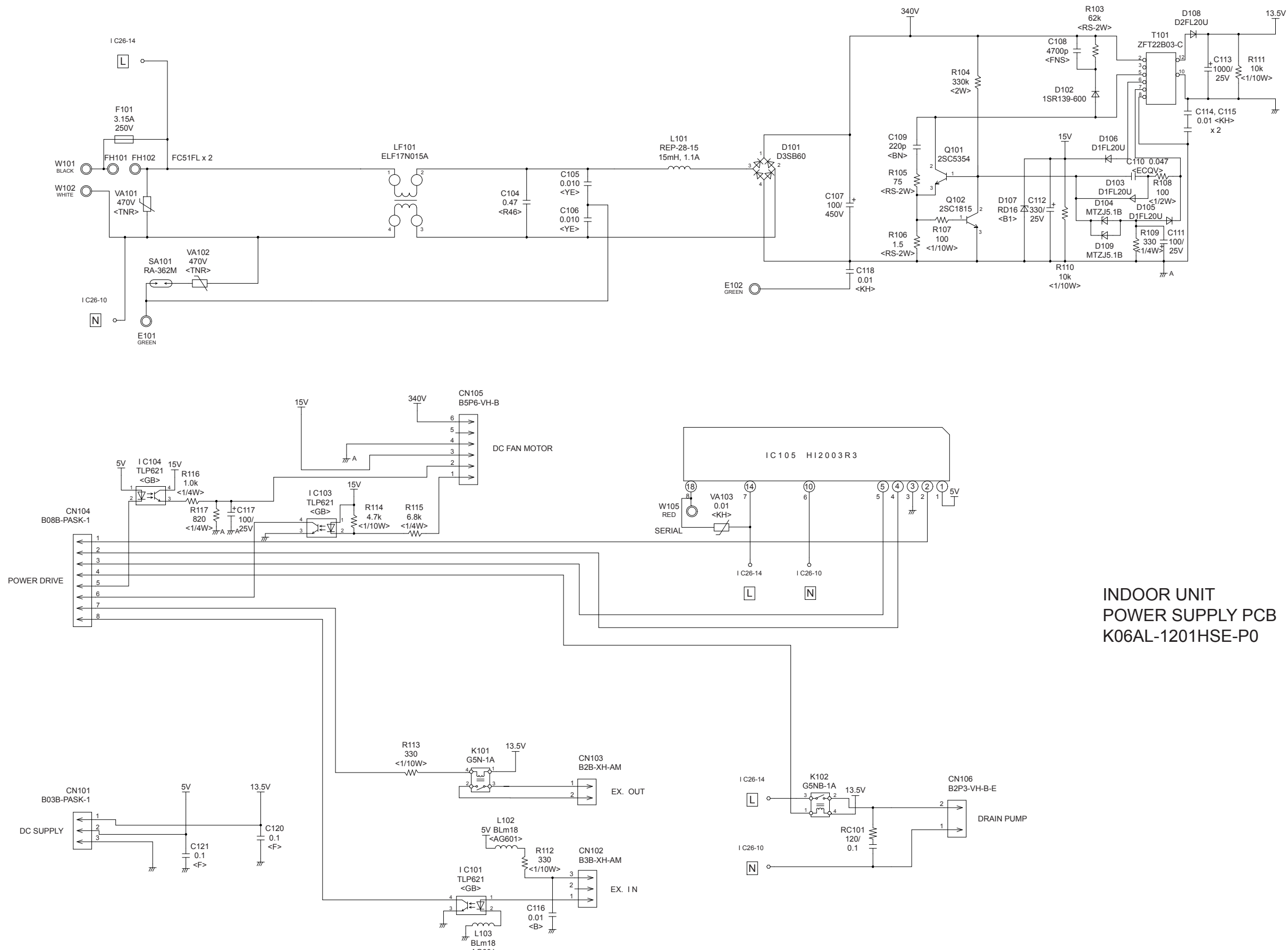

INDOOR UNIT
POWER SUPPLY PCB
K06AL-1201HSE-P0

INDOOR UNIT
INDICATOR PCB
K06AG-1000HSE-D0

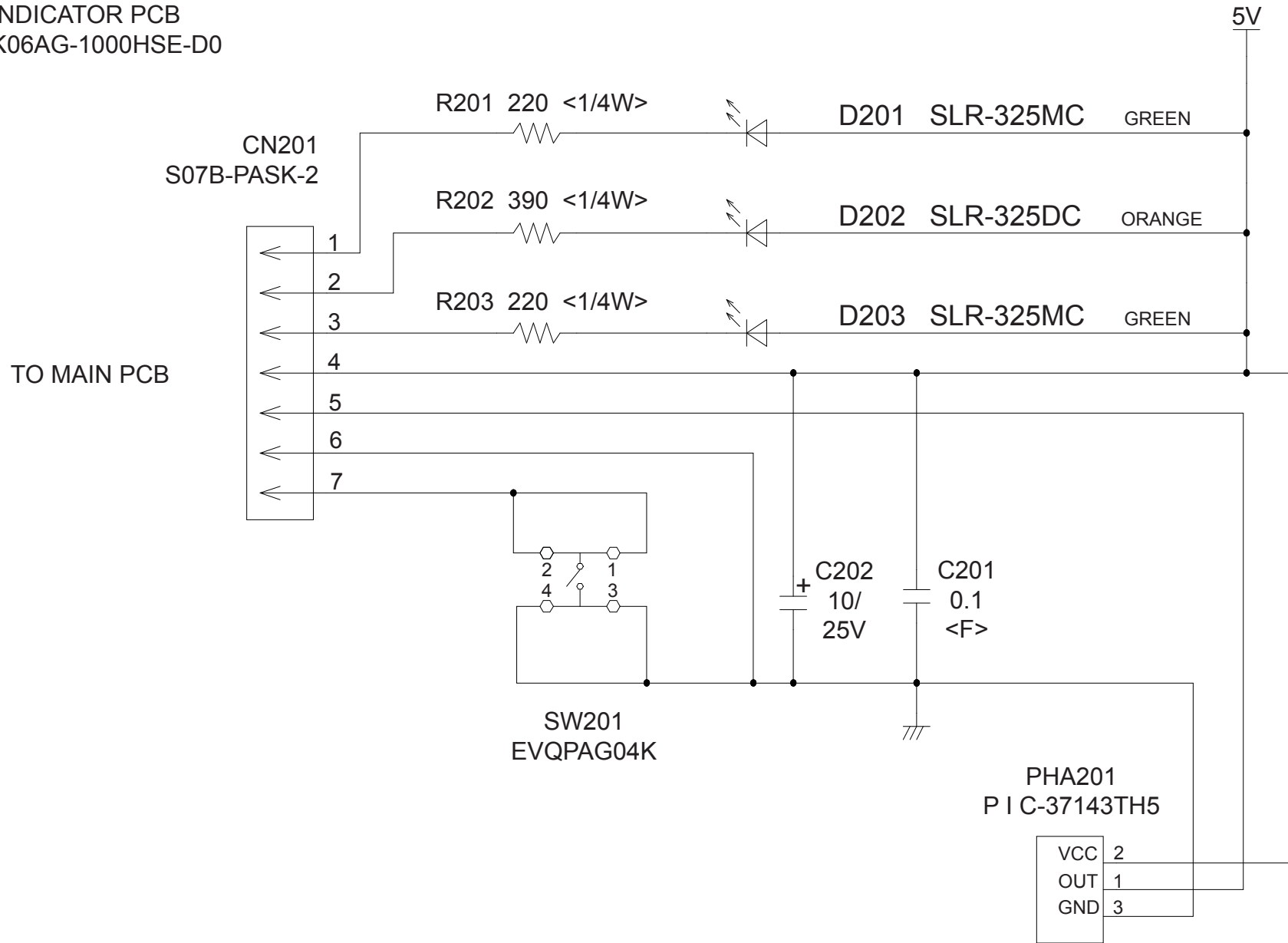

OUTDOOR PCB CIRCUIT DIAGRAM

INVERTER ASSEMBLY
EZ-0121EHUE

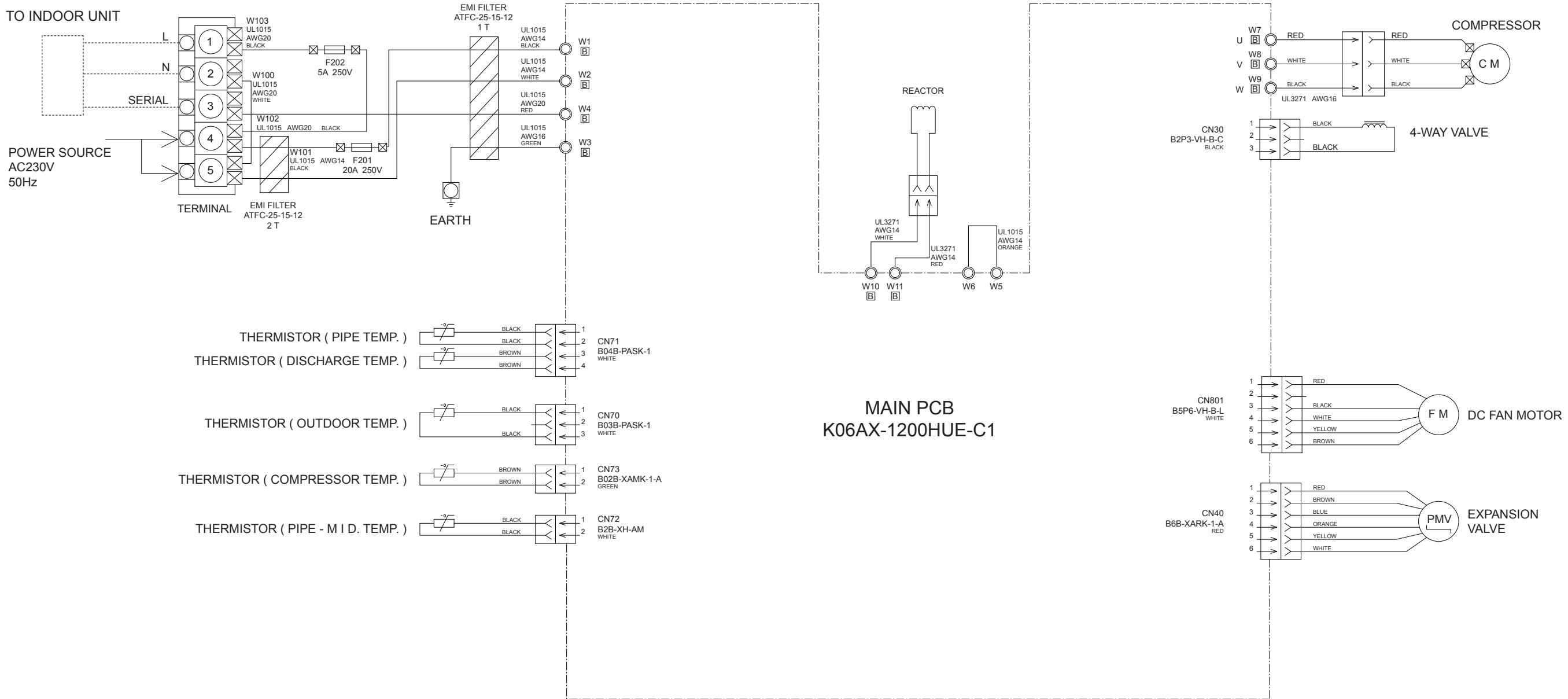

OUTDOOR UNIT MAIN PCB K06AX-1200HUE-C1

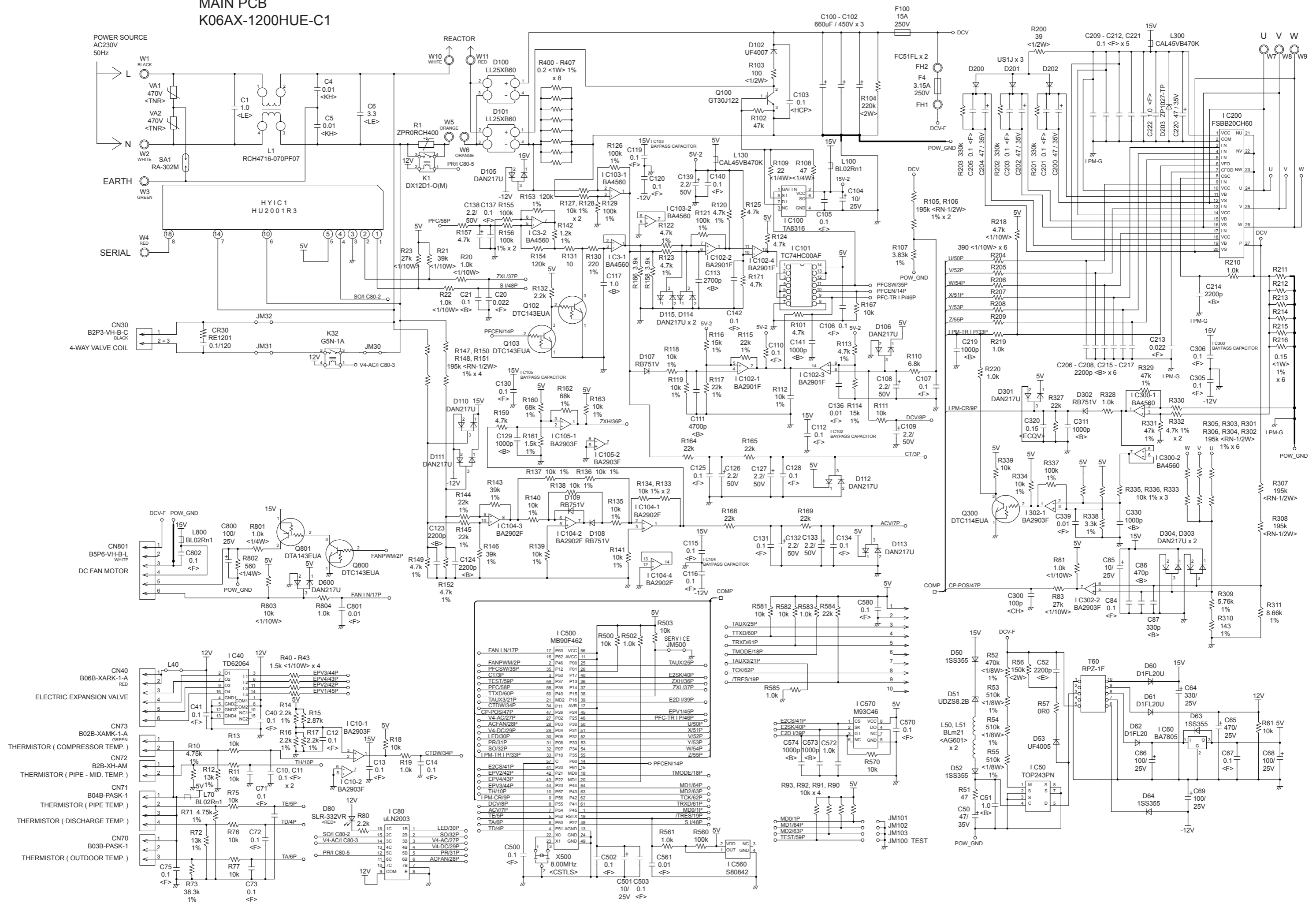

ERROR DETECTION

WIRED REMOTE CONTROL

This is possible only on a wired remote control.
If an error occurs, the following display will be shown.
("Er" will appear in the set room temperature display.)

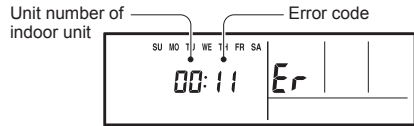

EX. Self-diagnosis

INDOOR UNIT (CASSETTE)

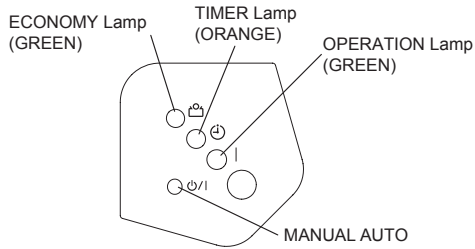

- : 0.5s on / 0.5s off
- ◇ : 0.1s on / 0.1s off
- () : Number of flashing

Indoor unit			Wired remote control	Description
OPERATION lamp (green)	TIMER lamp (orange)	ECONOMY lamp (green)		
● (1)	● (1)	◇	11	Serial communication error
● (1)	● (2)	◇	12	Wired remote control communication error
● (1)	● (5)	◇	15	Check run unfinished
● (2)	● (1)	◇	21	Unit number or Refrigerant circuit address setting error [Simultaneous Multi]
● (2)	● (2)	◇	22	Indoor unit capacity error
● (2)	● (3)	◇	23	Combination error
● (2)	● (4)	◇	24	• Connection unit number error (indoor slave unit) [Simultaneous Multi] • Connection unit number error (indoor unit or branch unit) [Flexible Multi]
● (2)	● (7)	◇	27	Master unit, slave unit set-up error [Simultaneous Multi]
● (3)	● (1)	◇	31	Power supply interruption error
● (3)	● (2)	◇	32	Indoor unit PCB model information error
● (3)	● (5)	◇	35	Manual auto switch error
● (4)	● (1)	◇	41	Inlet air temp. sensor error
● (4)	● (2)	◇	42	Indoor unit Heat Ex. Middle temp. sensor error
● (5)	● (1)	◇	51	Indoor unit fan motor error
● (5)	● (3)	◇	53	Drain pump error
● (5)	● (7)	◇	57	Damper error
● (5)	● (15)	◇	5U	Indoor unit error
● (6)	● (2)	◇	62	Outdoor unit main PCB model information error or communication error
● (6)	● (3)	◇	63	Inverter error
● (6)	● (4)	◇	64	Active filter error, PFC circuit error
● (6)	● (5)	◇	65	Trip terminal Error
● (6)	● (10)	◇	6A	Display PCB microcomputers communication error

Indoor unit			Wired remote control	Description
OPERATION lamp (green)	TIMER lamp (orange)	ECONOMY lamp (green)		
● (7)	● (1)	◇	71	Discharge temp. sensor error
● (7)	● (2)	◇	72	Compressor temp. sensor error
● (7)	● (3)	◇	73	Outdoor unit Heat Ex. liquid temp. sensor error
● (7)	● (4)	◇	74	Outdoor temp. sensor error
● (7)	● (5)	◇	75	Suction Gas temp. sensor error
● (7)	● (6)	◇	76	• 2-way valve temp. sensor error • 3-way valve temp. sensor error
● (7)	● (7)	◇	77	Heat sink temp. sensor error
● (8)	● (2)	◇	82	• Sub-cool Heat Ex. gas inlet temp. sensor error • Sub-cool Heat Ex. gas outlet temp. sensor error
● (8)	● (3)	◇	83	Liquid pipe temp. sensor error
● (8)	● (4)	◇	84	Current sensor error
● (8)	● (6)	◇	86	• Discharge pressure sensor error • Suction pressure sensor error • High pressure switch error
● (9)	● (4)	◇	94	Trip detection
● (9)	● (5)	◇	95	Compressor rotor position detection error (permanent stop)
● (9)	● (7)	◇	97	Outdoor unit fan motor error
● (9)	● (8)	◇	98	Outdoor unit fan motor 2 error
● (9)	● (9)	◇	99	4-way valve error
● (9)	● (10)	◇	9A	Coil (expansion valve) error
● (10)	● (1)	◇	A1	Discharge temp. error
● (10)	● (3)	◇	A3	Compressor temp. error
● (10)	● (4)	◇	A4	High pressure error
● (10)	● (5)	◇	A5	Low pressure error
● (13)	● (2)	◇	J2	Branch boxes error [Flexible Multi]

PARTS

DECORATION PANEL
UTG-UFYD-W

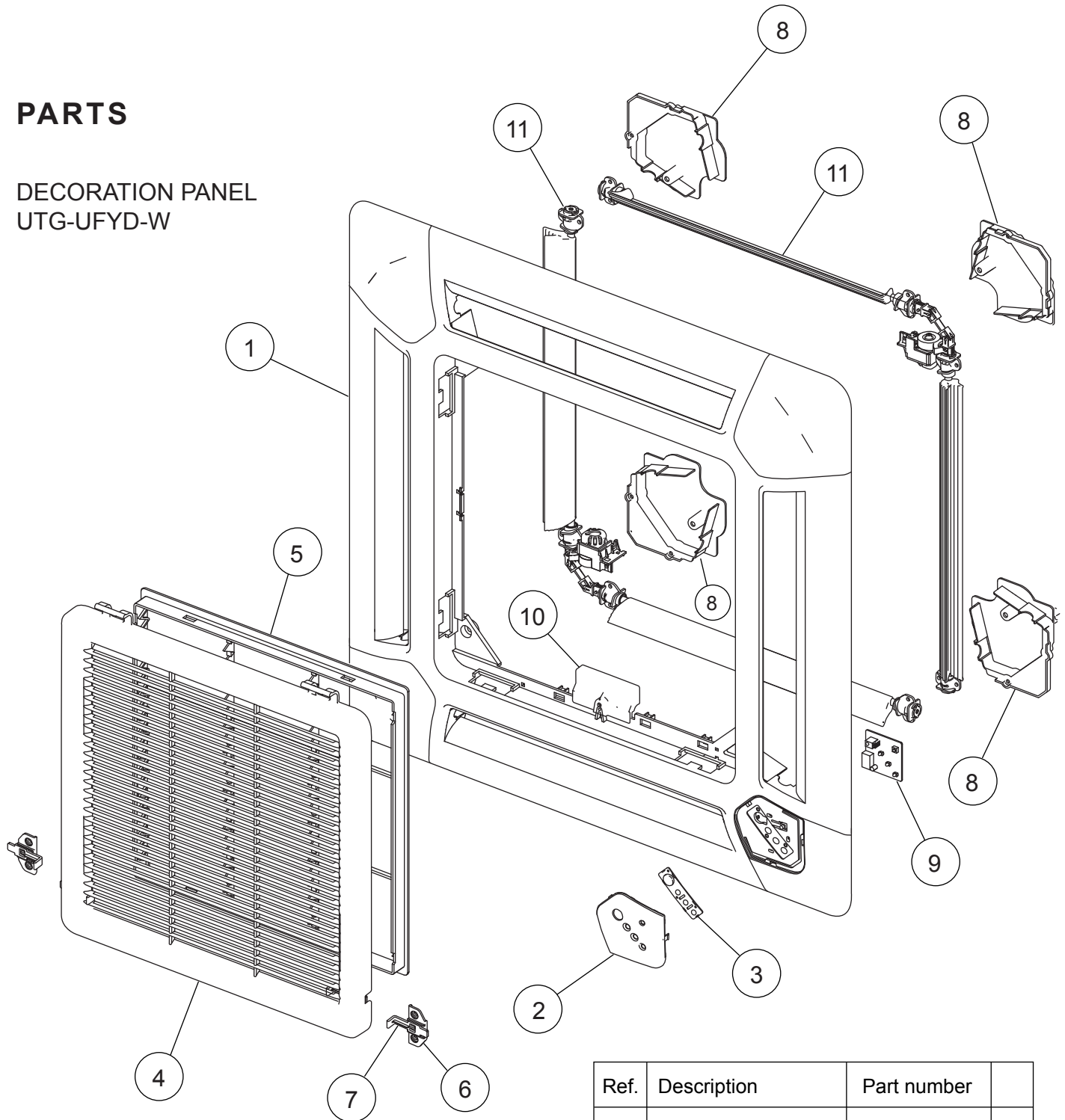

Ref.	Description	Part number
1	Decoration Panel	9375525040
2	Display Panel	9375529123
3	Receiver Window	9375547011
4	Intake Grille	9375531027
5	Long Life Filter	9375533014
6	Hook Bracket	9375546014
7	Grille Hook	9375532024
8	Panel Cover	9375530013
9	Indicator PCB Assy	9707371031
10	Connector Cover	9375549015
11	Flap Total Assy	9377760029

DECORATION PANEL
UTG-UFYD-W

Flap total assy
Motor holder assy

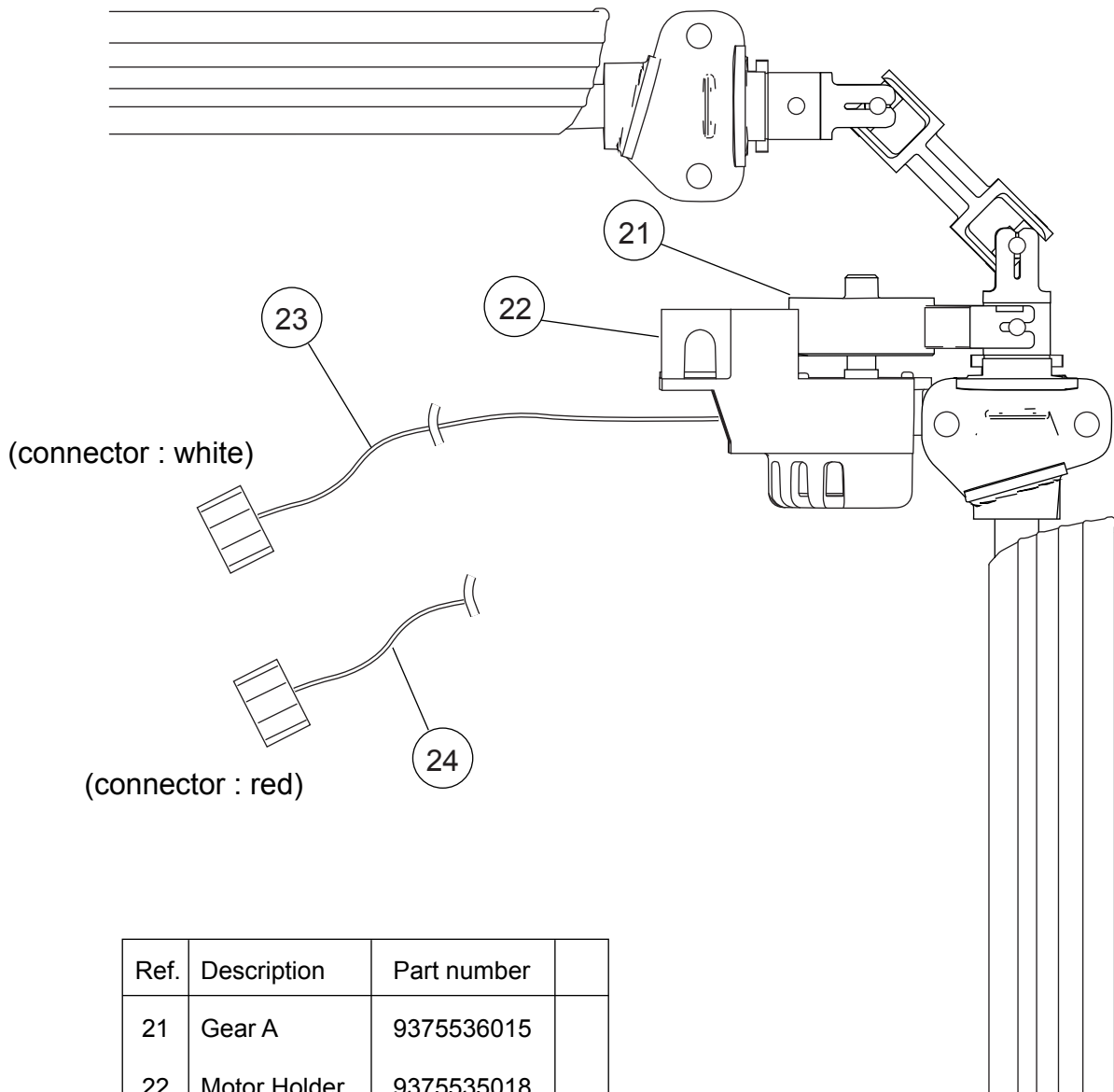

Ref.	Description	Part number	
21	Gear A	9375536015	
22	Motor Holder	9375535018	
23	Step Motor	9900139070	
24	Step Motor	9900139087	

PARTS

INDOOR UNIT

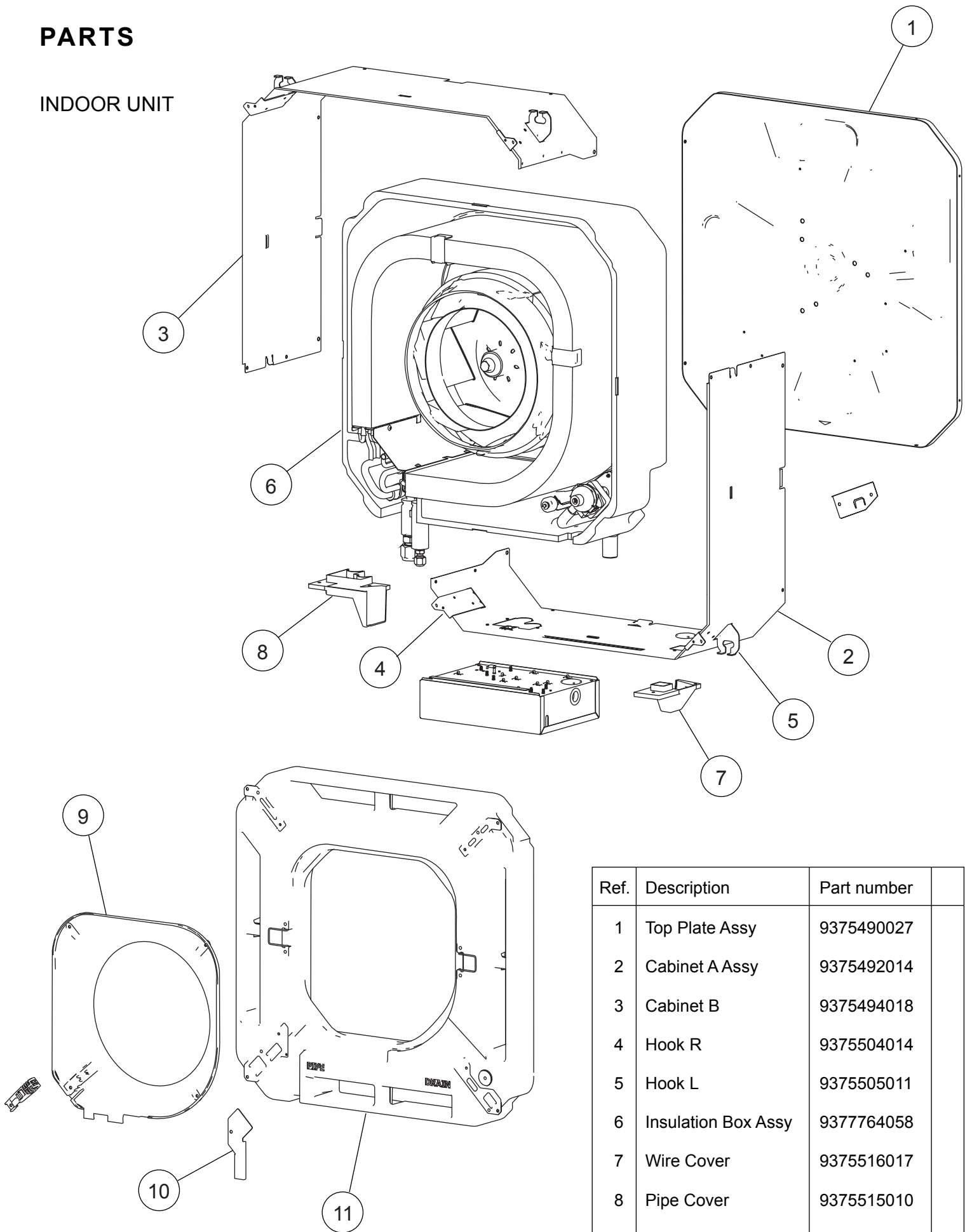

Ref.	Description	Part number
1	Top Plate Assy	9375490027
2	Cabinet A Assy	9375492014
3	Cabinet B	9375494018
4	Hook R	9375504014
5	Hook L	9375505011
6	Insulation Box Assy	9377764058
7	Wire Cover	9375516017
8	Pipe Cover	9375515010
9	Bell Mouse	9375503017
10	Wire Holder	9375478018
11	Drain Pan Sub Assy	9377765017

INDOOR UNIT

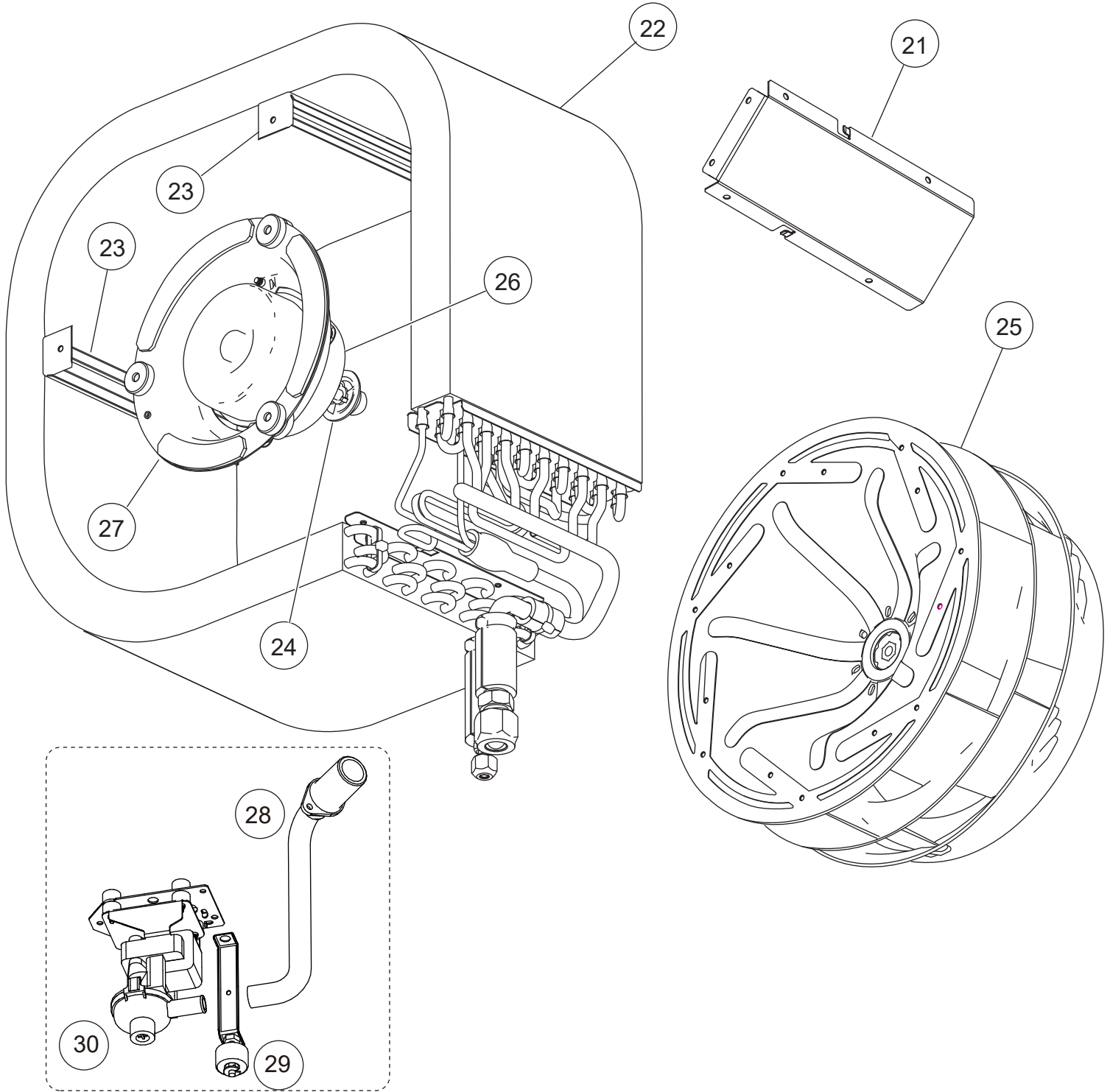

Ref.	Description	Part number
21	Separate Wall	9375506018
22	Evaporator Total Assy	9375720018
23	Evaporator Holder	9375507015
24	Turbo Fan Washer	9375487010
25	2 Stage Turbo Fan Assy	9375480011
26	Fan Motor	9602436019

Ref.	Description	Part number
27	Fan Motor Holder	9375552015
28	Drain port sub assy	9375718015
29	Float switch sub assy	9375721039
30	Drain pump sub assy	9375717025

INDOOR UNIT

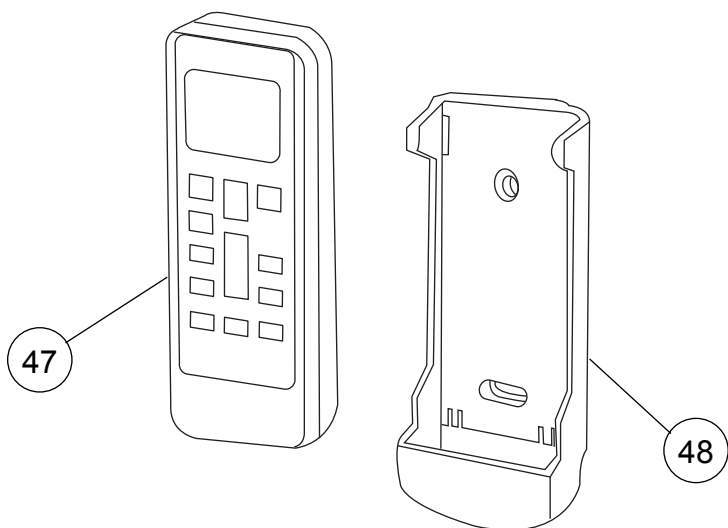
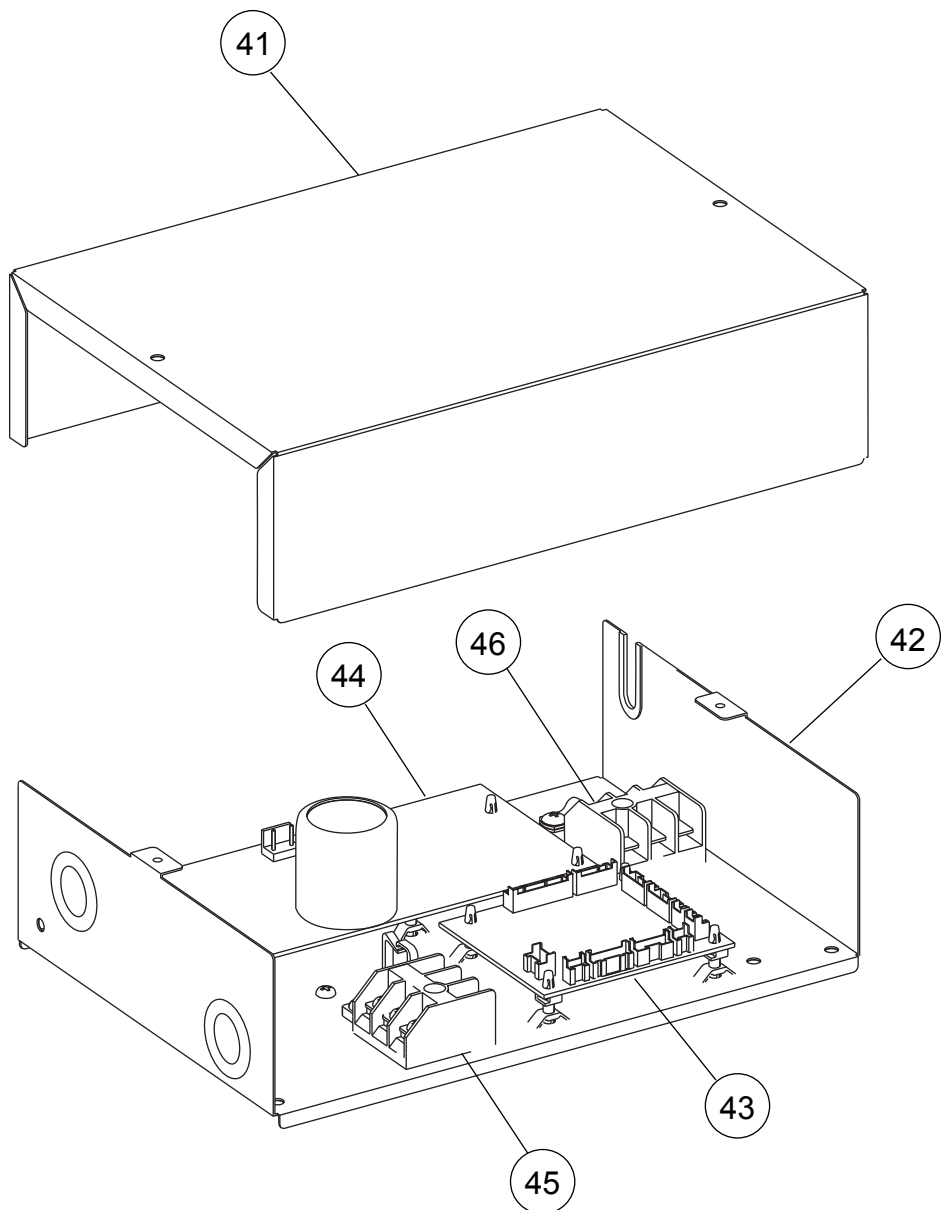

Ref.	Description	Part number
41	Control Box Cover	9375512019
42	Control Box A	9375511012
43	Main PCB	9709245149
44	Power Supply PCB	9707398380
45	Terminal	9306489045
46	Terminal	9703345012
47	Remote Control	9379219006
48	Remote Control Holder	9305642045
--	Pipe Thermistor	9703297014
--	Room Thermistor	9900502003

PARTS

OUTDOOR UNIT

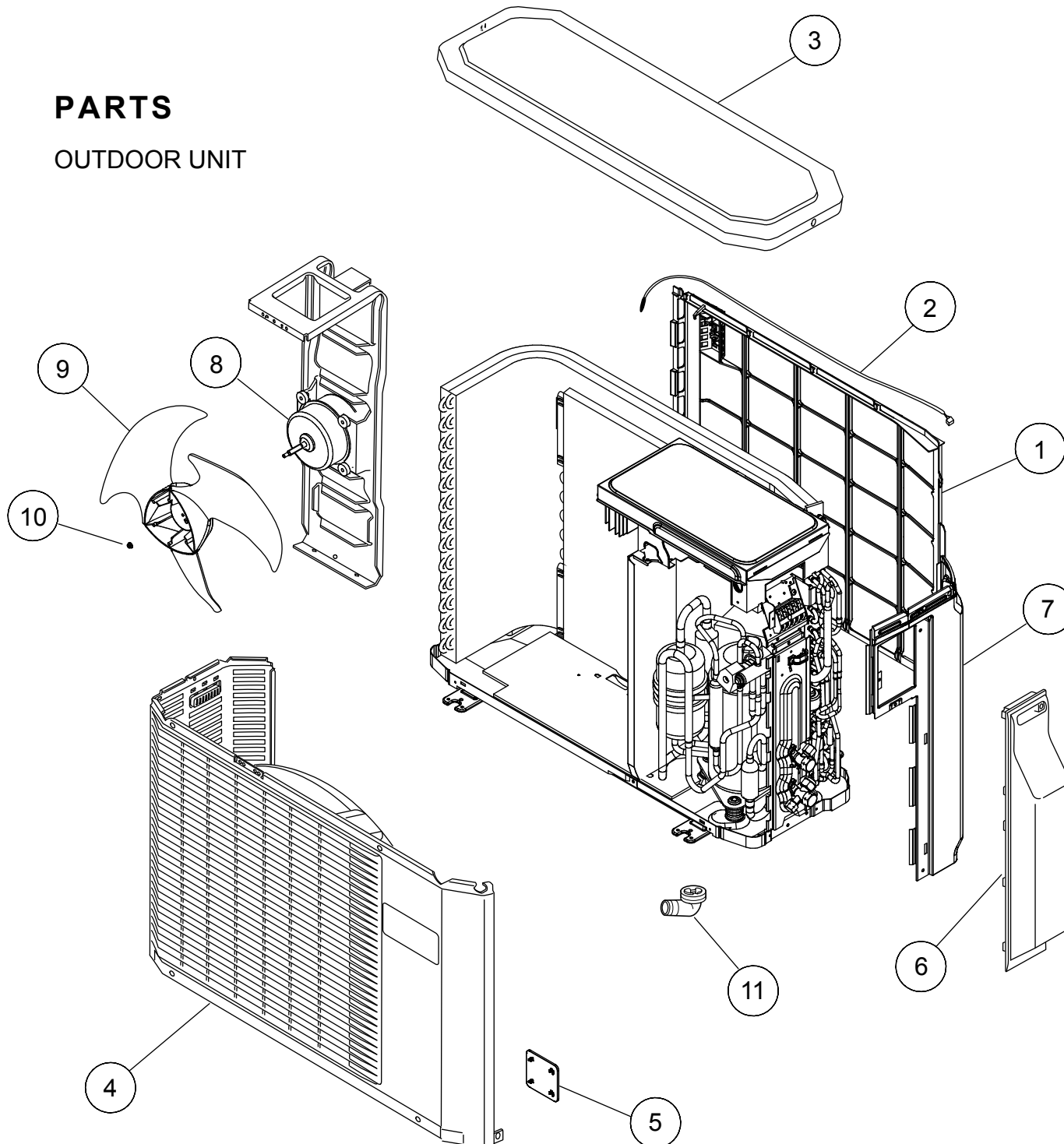

Ref	Description	Parts number
1	Protective Net	9315033017
2	Outdoor Thermistor	9900210045
3	Top Panel Assy	9309230057
4	Cabinet Assy	9312799459
5	Fan Guard Cover	9378110014
6	Switch Cover Assy	9309237032
7	Cabinet Right Assy	9309236028
8	Fan Motor	9602451012
9	Propeller Fan	9309909014
10	Nut with Washer	9304902003
11	Drain Assy	9303029015

OUTDOOR UNIT

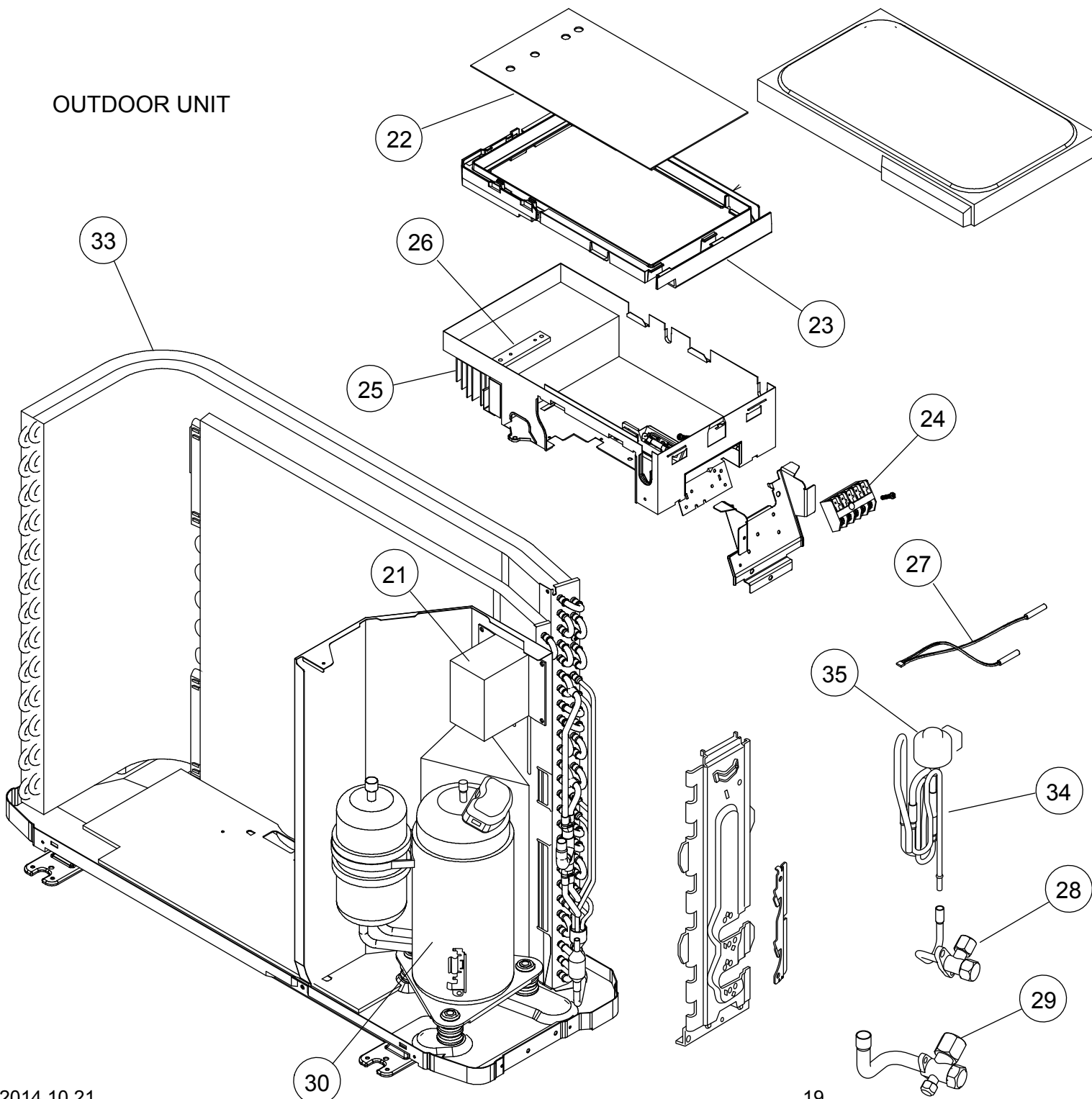



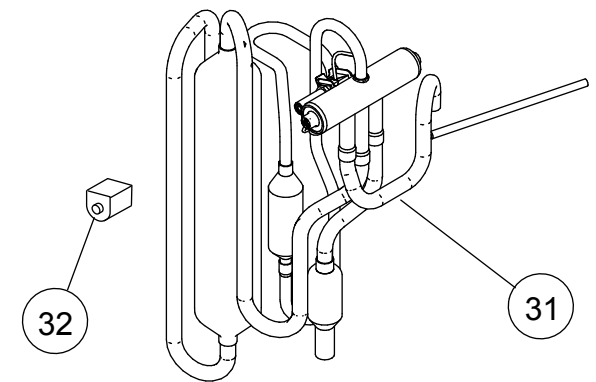



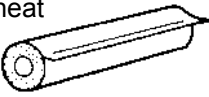
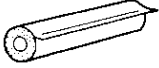

Ref	Description	Parts number
21	Reactor Assy	9900354015
22	Main PCB with grease	9709680322
23	PCB Holder	9313074029
24	Terminal	9703874031
25	Heat Sink A	9314410017
26	Heat Sink B	9314090011
27	Thermistor Assy	9900148027
28	2-way Valve Assy	9313062019
29	3-way Valve Assy	9315414014
30	Compressor Assy	9315297037
31	4-way Valve Assy	9315311023
32	Solenoid	9970055010
33	Condenser Sub Assy	9312069118
34	Pulse Motor Valve Assy	9315310019
35	Expansion Valve Coil	9900057039
--	Compressor Thermistor	9900156046
--	Heat Exchanger Thermistor	9900403010

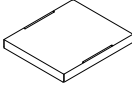
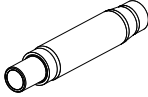

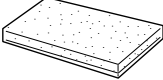
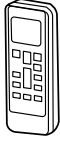
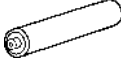



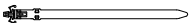

ACCESSORIES

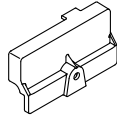
INDOOR UNIT

Name and Shape	Q'ty	Use
Coupler heat insulation (Large) 	1	For indoor side pipe joint (Gas pipe)
Coupler heat insulation (Small) 	1	For indoor side pipe joint (Liquid pipe)
Special nut A (Large flange) 	4	For installing indoor unit
Special nut B (Small flange) 	4	For installing indoor unit
Template (Carton top) 	1	For ceiling openings cutting Also used as packing
Drain hose 	1	For installing drain pipe
Hose Band 	1	For installing drain hose
Drain hose insulation 	1	For installing drain pipe
Remote control 	1	For air conditioner operation
Battery 	2	For remote control
Remote control holder 	1	For installing the remote control
Tapping screw (M3 × 12mm) 	2	For mounting the remote control holder
Binder 	2	For electrical wiring
Wire clammer 	1	For electrical wiring

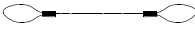

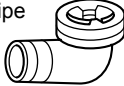

DECORATION PANEL UTG-UFYD-W

Name and Shape	Q'ty	Use
Connector cover 	1	For covering connector
Tapping Screw (M5 × 12 mm) 	4	For mounting decoration panel
Tapping Screw (M4 × 12 mm) 	1	For mounting connector cover
L angle 	2	For mounting the Hook Wire to the Decoration panel
Hook wire 	2	For suspending the Decoration panel
Screw [pitch small] (M4 × 10 mm) 	2	For mounting the Hook Wire (for metals)
Screw [pitch large] (M4 × 10 mm) 	4	For mounting the L angle and Hook wire (for resins)

OUTDOOR UNIT

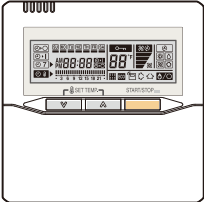
Name and Shape	Q'ty	Application	Part number
Drain pipe 	1	For outdoor unit drain piping work.	9303029015

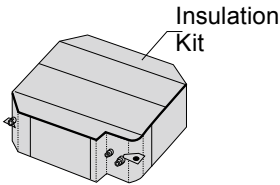
**INDOOR UNIT
OPTIONAL PARTS**

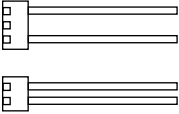
Name and Shape	Model name	Use
<p>Wired remote control</p> 	<p>UTY-RNNYM</p>	<p>Unit control is performed by wired remote control</p>
<p>Simple remote control</p> 	<p>UTY-RSNYM</p>	<p>Unit control is performed by simple remote control</p>
<p>Air outlet shutter plate</p> 	<p>UTR-YDZB</p>	<p>Air outlet shutter plate is installed at the air outlet when 3-way direction is performed.</p>
<p>Insulation kit for high humidity</p> 	<p>UTZ-KXGC</p>	<p>Install when the under roof condition is expected to be the humidity of over 80 % and the temperature of over 30°C</p>
<p>Fresh air intake kit</p> 	<p>UTZ-VXAA</p>	<p>It can be taken in fresh air of up to 10% of "high" air volume of the indoor unit by attaching Fresh Air Intake Kit to cassette type indoor unit.</p>
<p>Extrenal connect set</p> 	<p>UTY-XWZX</p>	<p>Use to connect with various peripheral devices and air conditioner PCB.</p>