

SPLIT TYPE
AIR CONDITIONER
DUCT TYPE (50Hz)

SERVICE MANUAL

Indoor unit	Outdoor unit
ARYG45LHTA	AOYG45LETL
ARYG54LHTA	AOYG54LETL



CONTENTS

SPECIFICATIONS	1
DIMENSIONS	2
REFRIGERANT SYSTEM DIAGRAM . . .	3
CIRCUIT DIAGRAM	4
INDOOR PCB CIRCUIT DIAGRAM	5
OUTDOOR PCB CIRCUIT DIAGRAM . . .	6
ERROR DETECTION	12
PARTS (INDOOR UNIT)	16
PARTS (OUTDOOR UNIT)	18
ACCESSORIES	21

SPECIFICATIONS

ELECTRICAL DATA

TYPE		Cooling & Heating	
INDOOR UNIT		ARYG45LHTA	ARYG54LHTA
OUTDOOR UNIT		AOYG45LETL	AOYG54LETL
COOLING CAPACITY		12.5 kW	13.4 kW
HEATING CAPACITY		14.0 kW	16.0 kW
POWER SOURCE		230 V, 50 Hz, single phase	
RUNNING CURRENT	Cooling	18.9 A	20.9 A
	Heating	16.7 A	20.5 A
INPUT WATTS	Cooling	4.30 kW	4.77 kW
	Heating	3.80 kW	4.69 kW
E.E.R.	Cooling	2.91 kW/kW	2.81 kW/kW
C.O.P.	Heating	3.68 kW/kW	3.41 kW/kW
MOISTURE REMOVAL		1.5 L/hr	2.0 L/hr
AIRCIRCULATION INDOOR		3,350 m3/h	3,350 m3/h
AIRCIRCULATION OUTDOOR	Cooling	6,750 m3/h	6,750 m3/h
	Heating	6,200 m3/h	6,200 m3/h
MAXIMUM CURRENT		22.5 A	23.5 A

FAN MOTOR

INDOOR UNIT, Discrimination		MFA-60TTFS	
INDOOR UNIT	High	1,300 r.p.m.	
	Medium	1,150 r.p.m.	
	Low	1,000 r.p.m.	
OUTDOOR UNIT, Discrimination		MFE-45VVT	
OUTDOOR UNIT Cooling	Upper fan	850 r.p.m.	850 r.p.m.
	Lower fan	800 r.p.m.	800 r.p.m.
OUTDOOR UNIT Heating	Upper fan	780 r.p.m.	780 r.p.m.
	Lower fan	750 r.p.m.	750 r.p.m.

NOISE LEVEL

INDOOR UNIT	High	47 dB	
	Medium	43 dB	
	Low	40 dB	
OUTDOOR UNIT	Cooling	55 dB	55 dB
	Heating	55 dB	57 dB

COMPRESSOR AND REFRIGERANT

TYPE		Hermetic type, Inverter, 6 poles, DC motor, Twin Rotary	
DISCRIMINATION		N-TF30HD1A	
WEIGHT (with oil)		15.4 kg	
REFRIGERANT TYPE		R410A	
PRECHARGED REFRIGERANT		3,350 g	
MAX PIPE HEIGHT		30 m	
FULL CHARGE	Pipe length	20 m	3,350 g
		30 m	3,750 g
		40 m	4,150 g
		50 m	4,550 g
ADDITIONAL CHARGE		40 g/m	

DIMENSIONS

INDOOR UNIT	H x W x D	400 x 1,050 x 500 mm
OUTDOOR UNIT	H x W x D	1,290 x 900 x 330 mm

WEIGHT

INDOOR UNIT	Shipping / Net	51 kg / 46 kg
OUTDOOR UNIT	Shipping / Net	94 kg / 86 kg

DIMENSIONS

(Unit : mm)

INDOOR UNIT

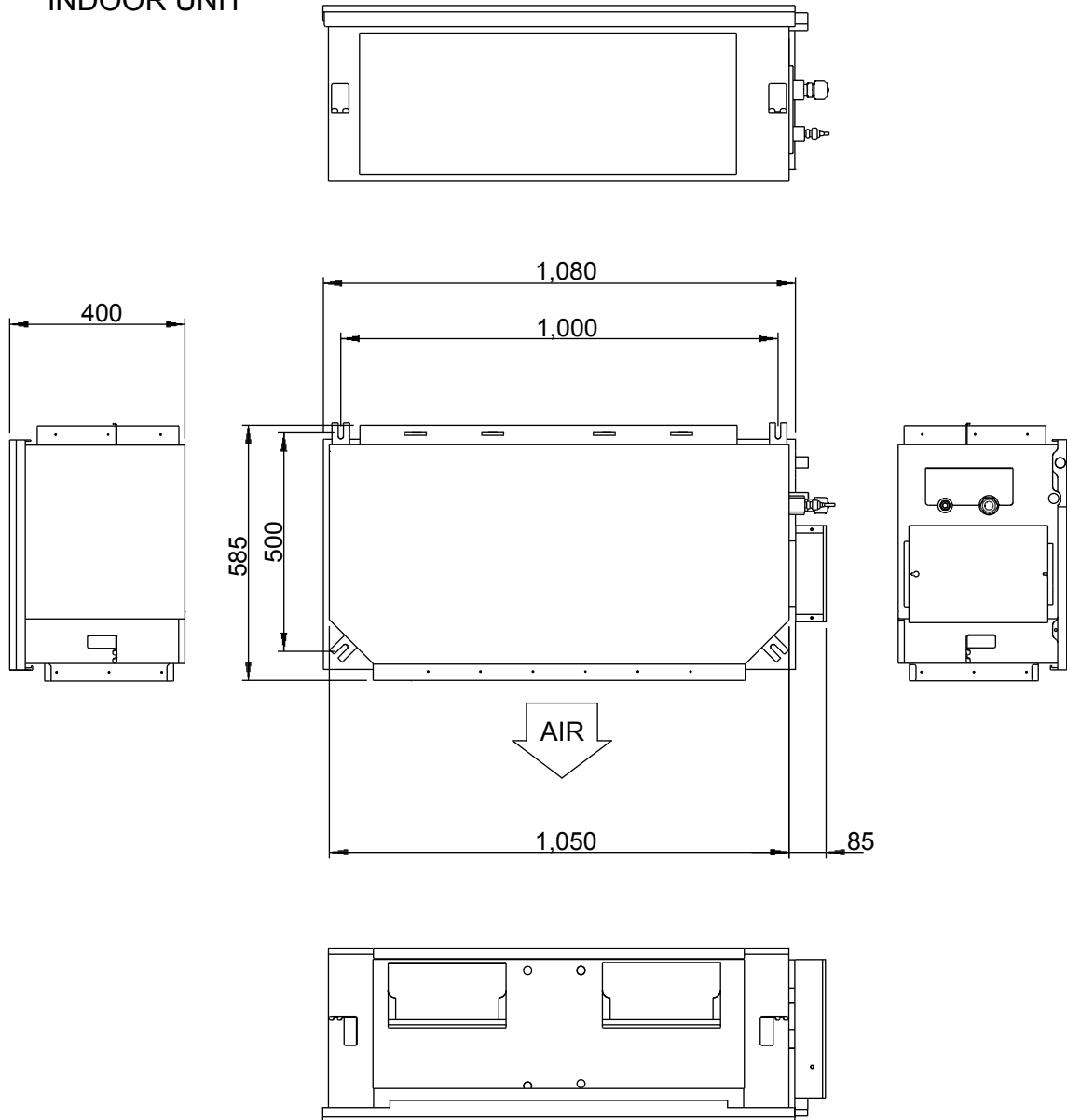

OUTDOOR UNIT

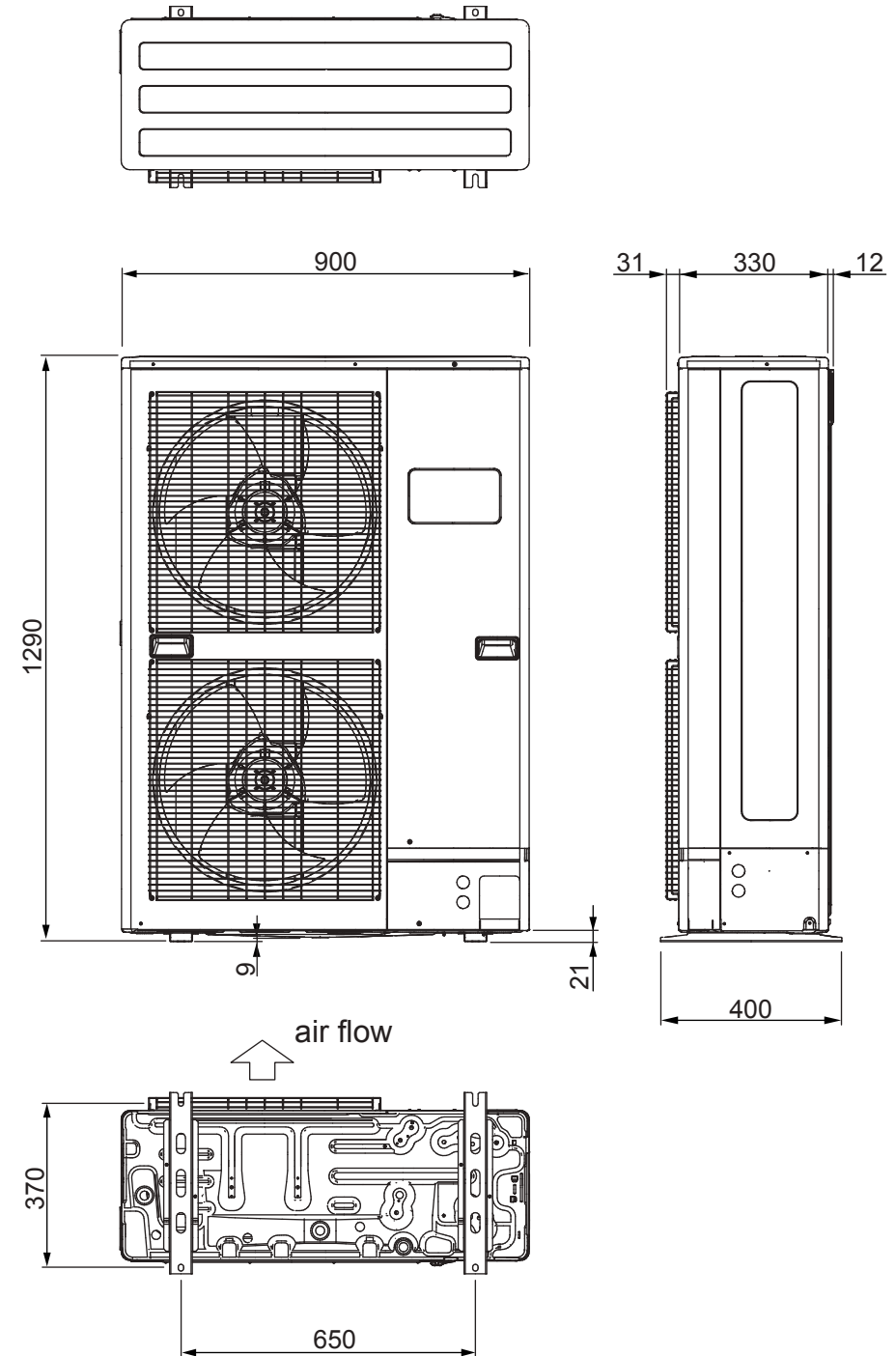

REFRIGERANT SYSTEM DIAGRAM

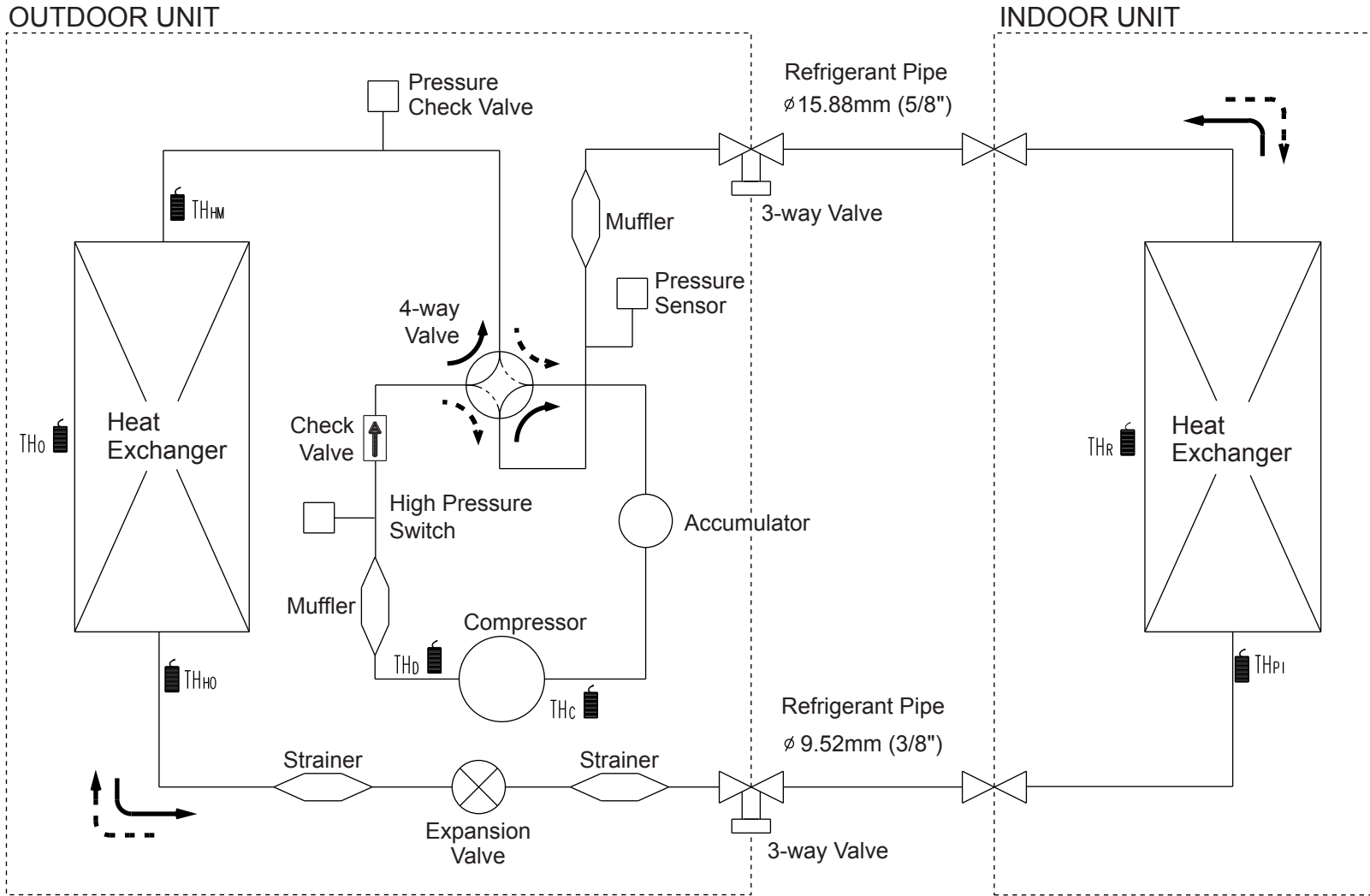

Refrigerant direction

→ Cool

- - - - - Heat

TH_c : Thermistor (Compressor)

TH_d : Thermistor (Discharge)

TH_{HM} : Thermistor (Heat Exchanger Med)

TH_{Ho} : Thermistor (Heat Exchanger Out)

TH_o : Thermistor (Outdoor)

TH_R : Thermistor (Room)

TH_{Pi} : Thermistor (Pipe)

CIRCUIT DIAGRAM

INDOOR UNIT

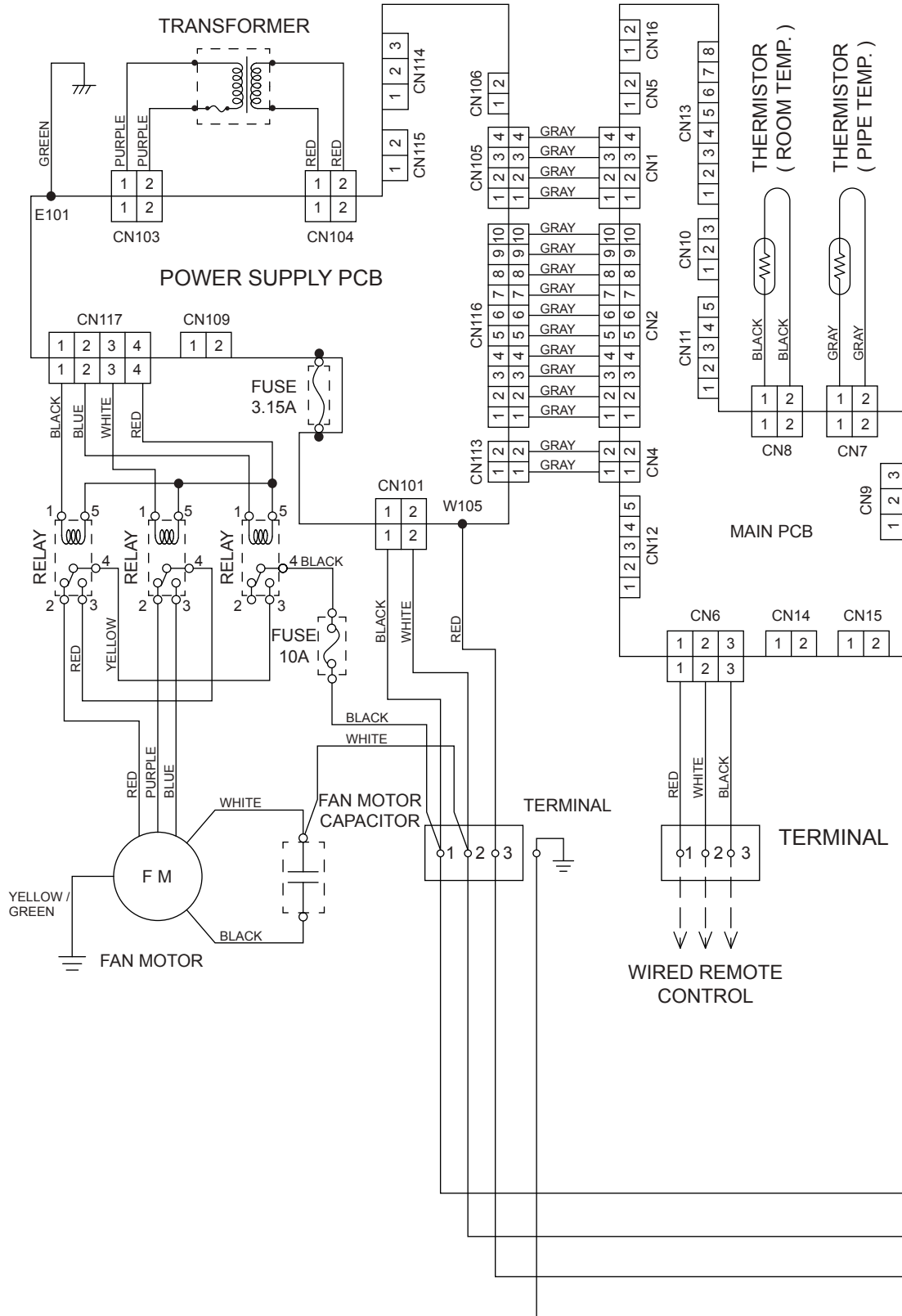

OUTDOOR UNIT

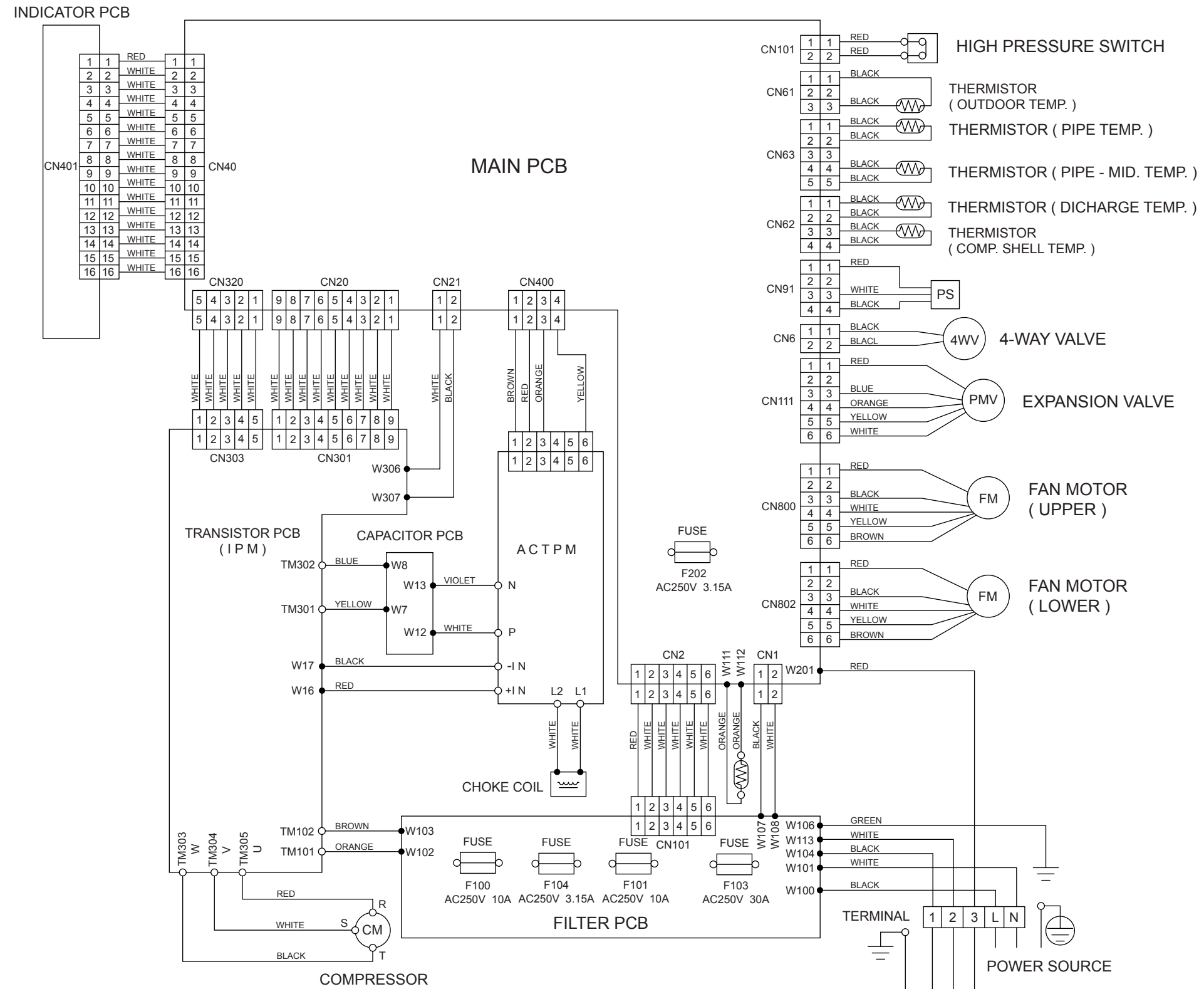

**POWER SUPPLY PCB
K04CW-1100HSE-P0**

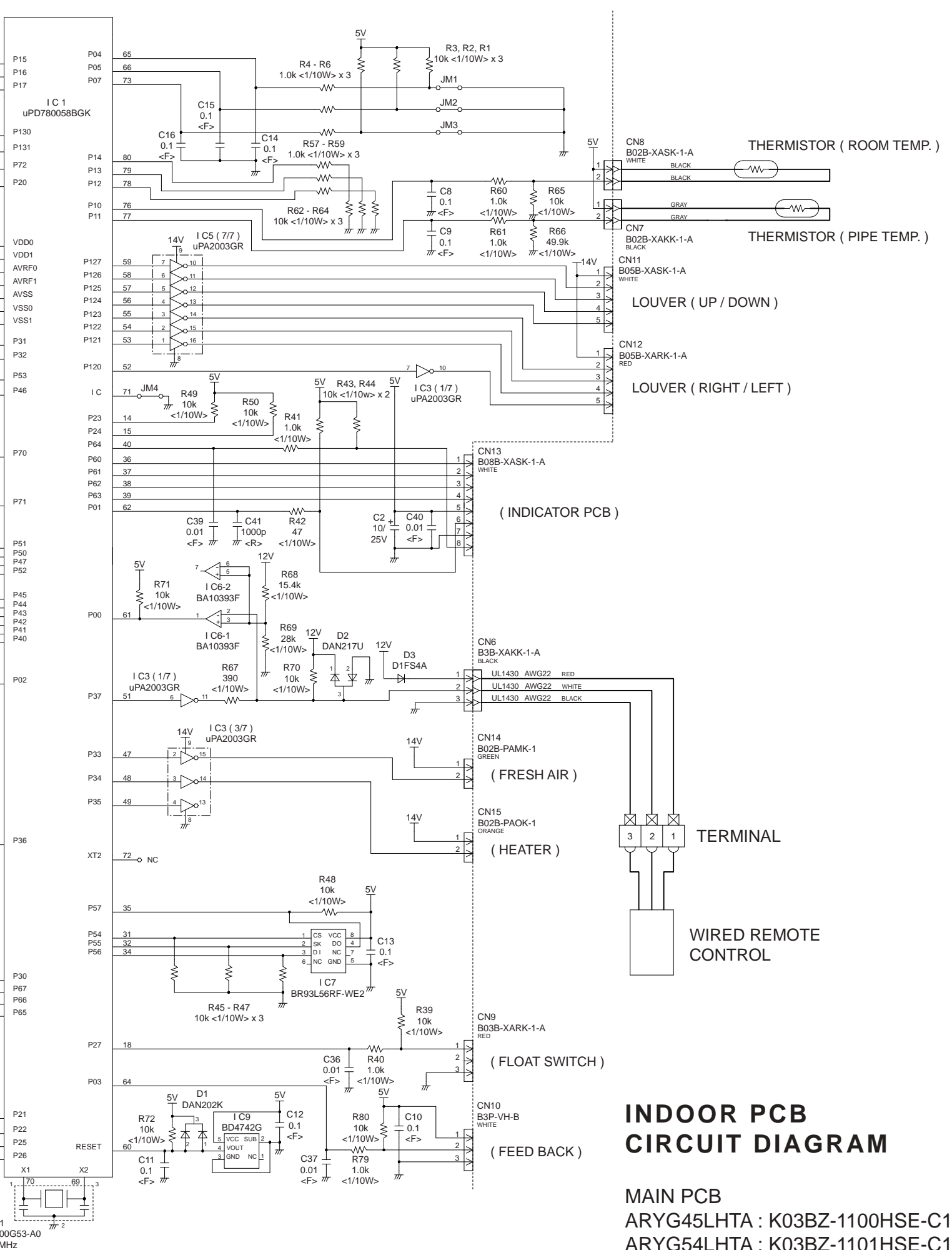
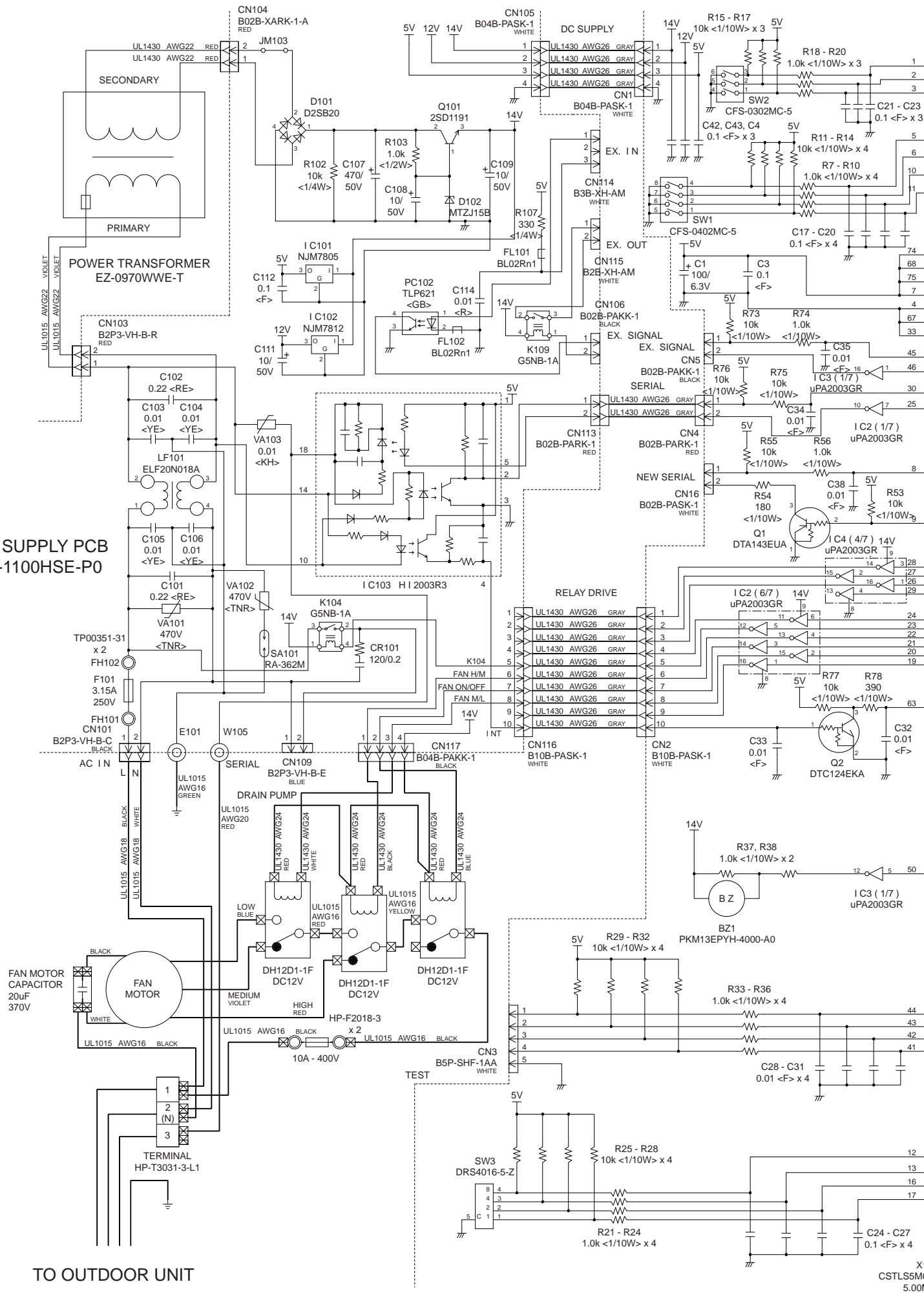

**INDOOR PCB
CIRCUIT DIAGRAM**

MAIN PCB
 ARYG45LHTA : K03BZ-1100HSE-C1
 ARYG54LHTA : K03BZ-1101HSE-C1

OUTDOOR PCB CIRCUIT DIAGRAM

INVERTER ASSEMBLY

AOYG45LETL : EZ-0121HHUE

AOYG54LETL : EZ-0121KHUE

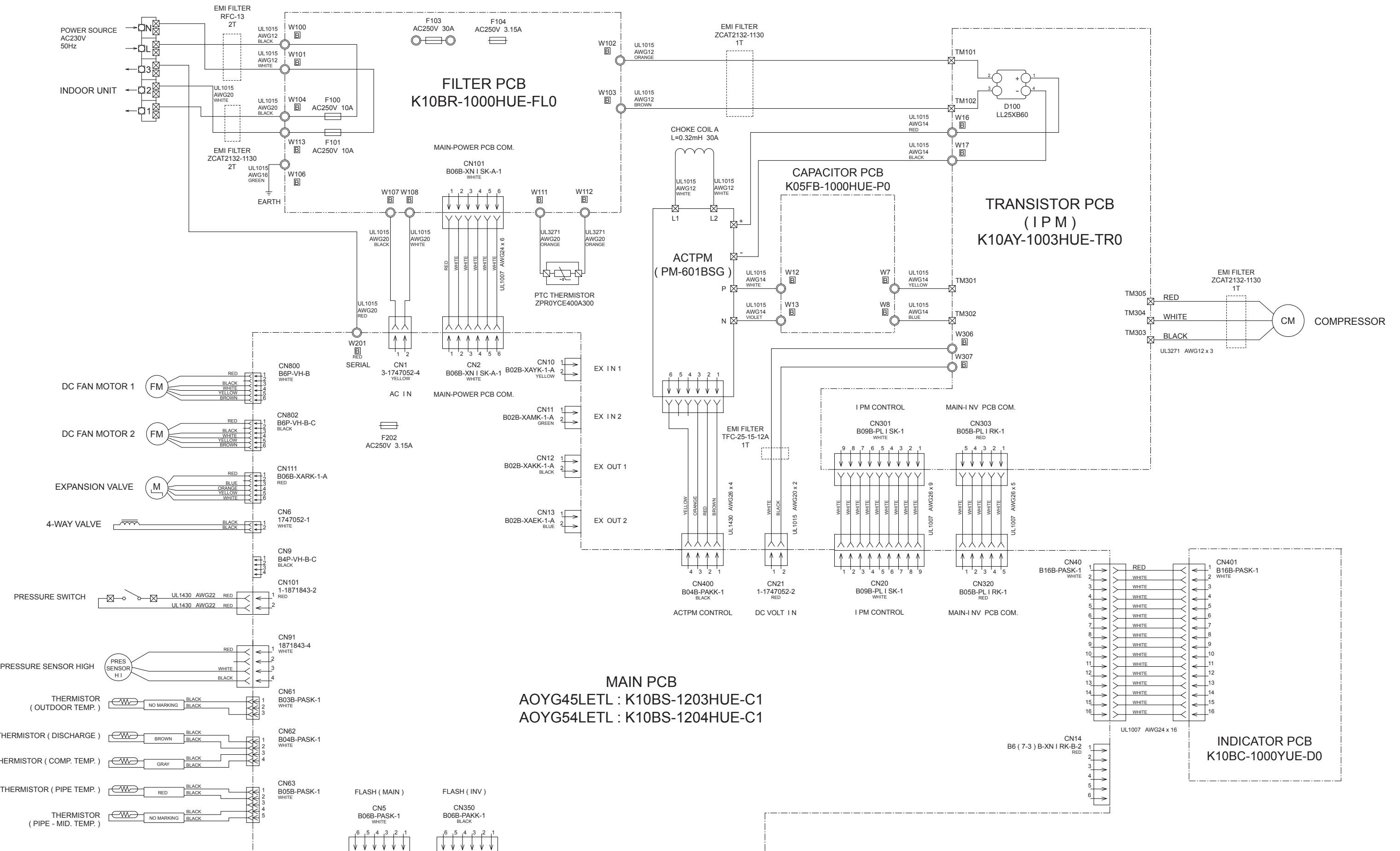

OUTDOOR UNIT
 MAIN PCB - 1
 AOYG45LETL : K10BS-1203HUE-C1
 AOYG54LETL : K10BS-1204HUE-C1

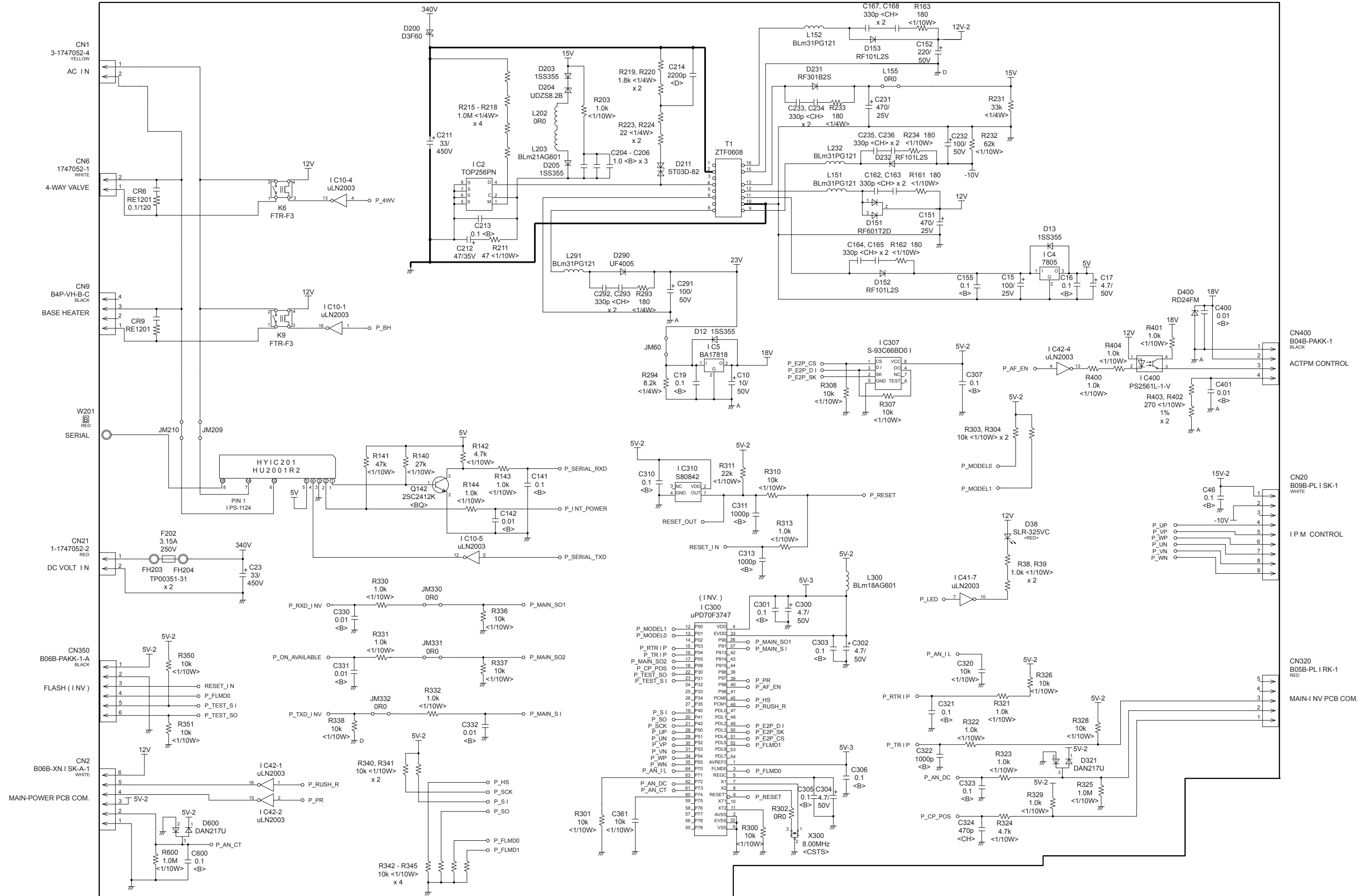

OUTDOOR UNIT
 MAIN PCB - 2
 AOYG45LETL : K10BS-1203HUE-C1
 AOYG54LETL : K10BS-1204HUE-C1

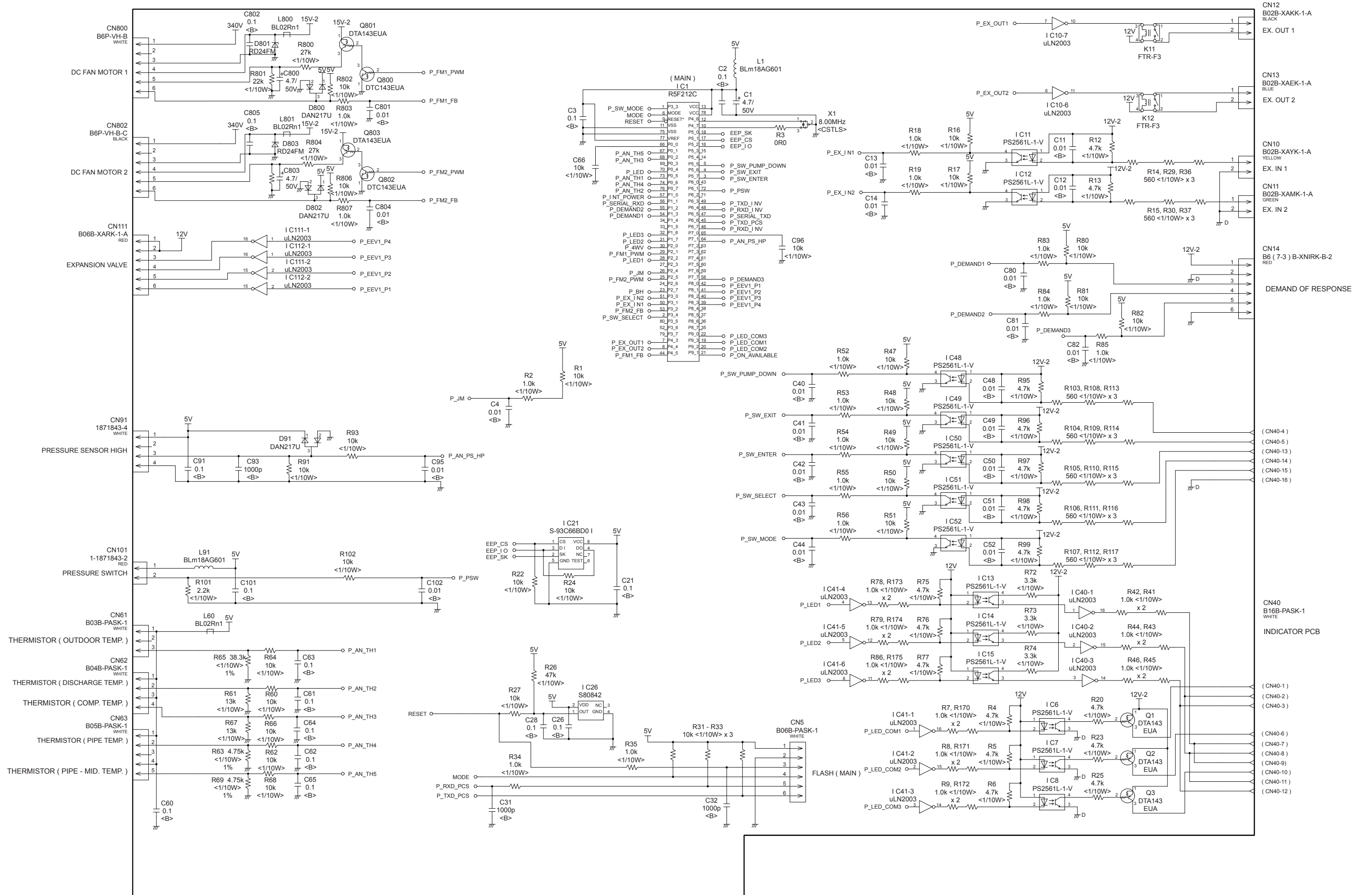

OUTDOOR UNIT TRANSISTOR PCB (I P M) K10AY-1003HUE-TR0

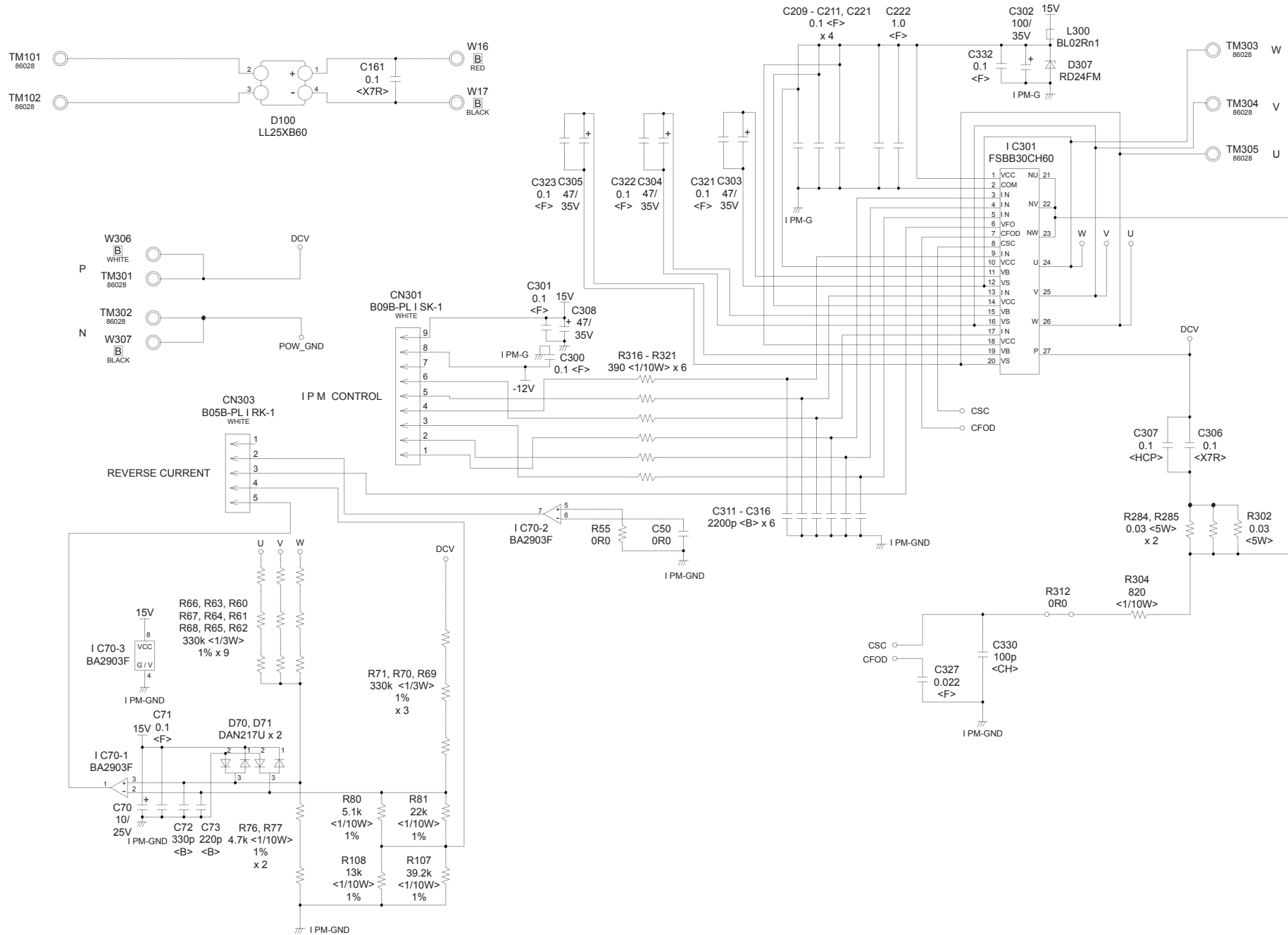

OUTDOOR UNIT POWER SUPPLY PCB K10BR-1000HUE-FL0

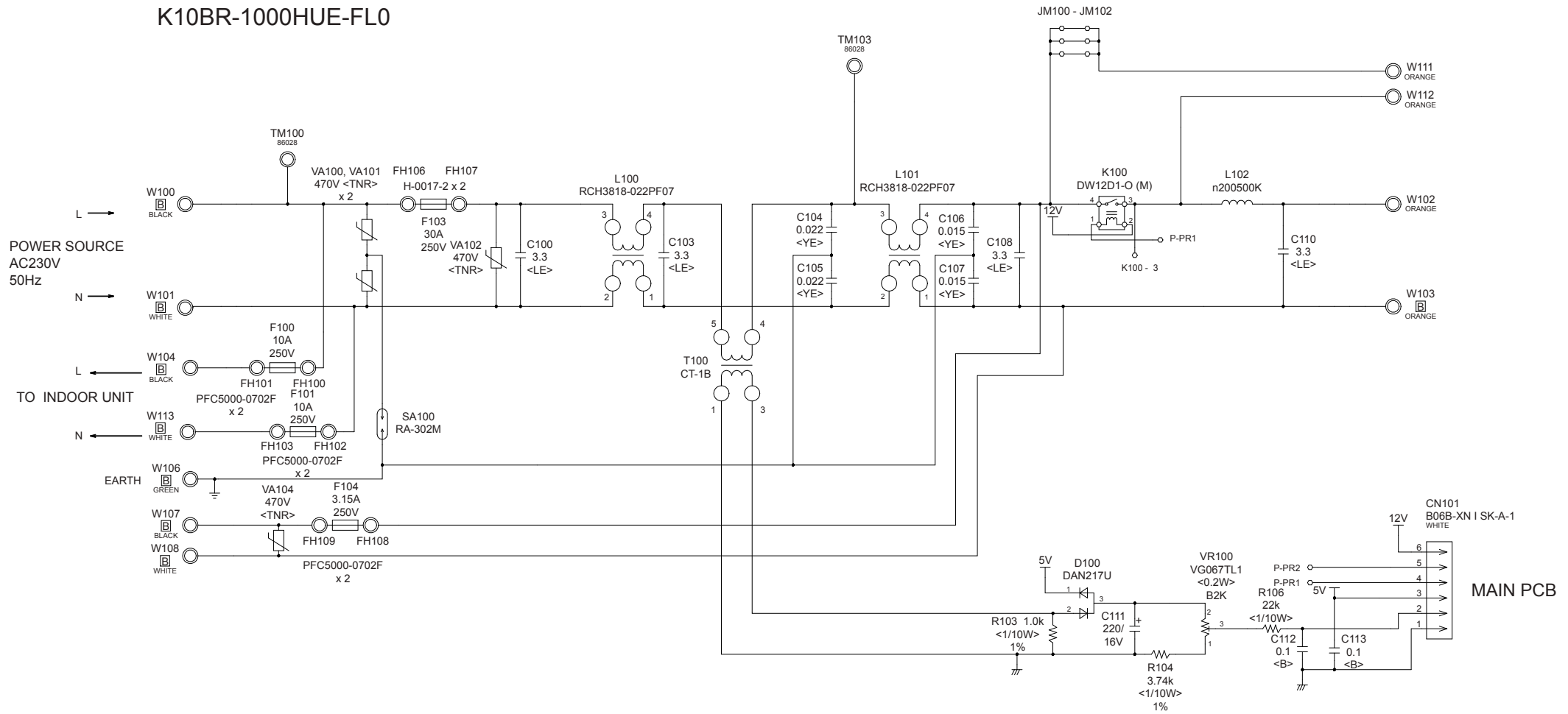

OUTDOOR UNIT
CAPACITOR PCB
K05FB-1000HUE-P0

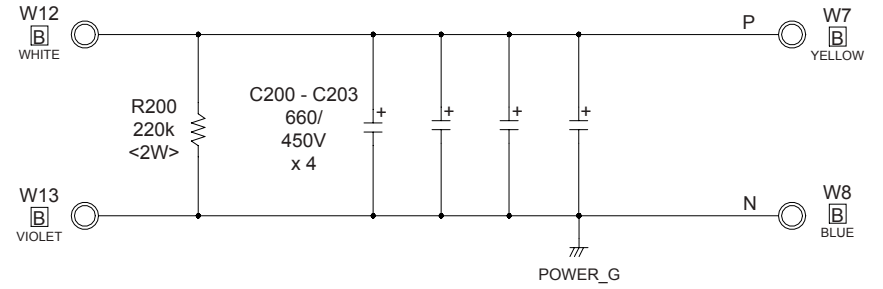

OUTDOOR UNIT
INDICATOR PCB
K10BC-1000YUE-D0

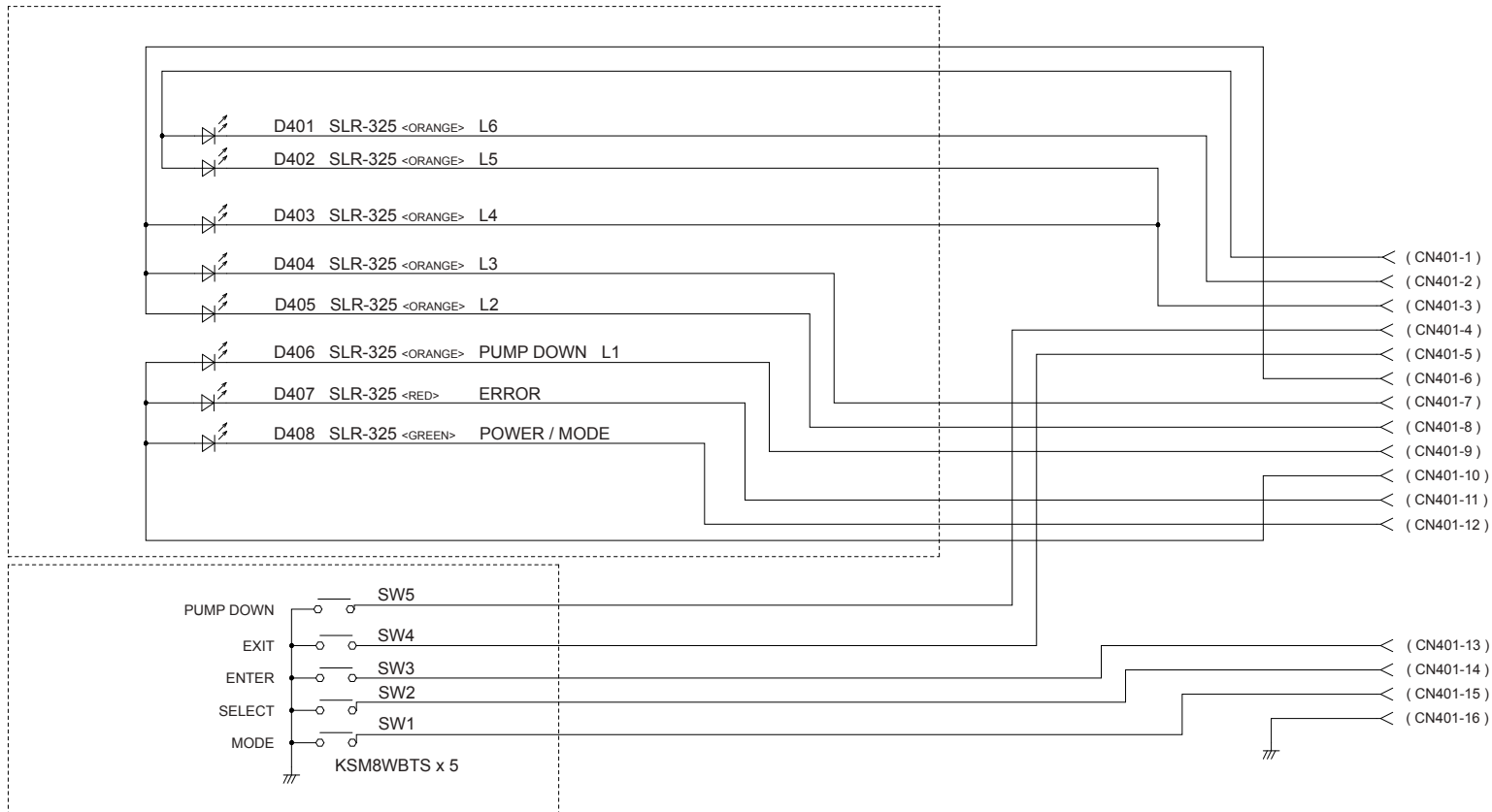

ERROR DETECTION

WIRED REMOTE CONTROL

This is possible only on a wired remote control.

If an error occurs, the following display will be shown.

("Er" will appear in the set room temperature display.)

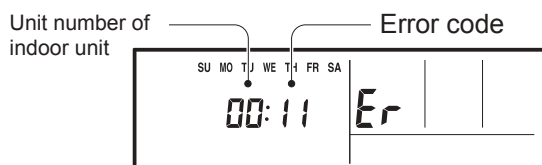

EX. Self-diagnosis

Code	Description
11	Serial communication error
12	Wired remote control communication error
15	Check run unfinished
21	Unit number or Refrigerant circuit address setting error [Simultaneous Multi]
22	Indoor unit capacity error
23	Combination error
24	<ul style="list-style-type: none"> • Connection unit number error (indoor slave unit) [Simultaneous Multi] • Connection unit number error (indoor unit or branch unit) [Flexible Multi]
27	Master unit, slave unit set-up error [Simultaneous Multi]
31	Power supply interruption error
32	Indoor unit PCB model information error
35	Manual auto switch error
41	Inlet air temp. sensor error
42	Indoor unit Heat Ex. Middle temp. sensor error
51	Indoor unit fan motor error
53	Drain pump error
57	Damper error
5U	Indoor unit error
62	Outdoor unit main PCB model information error or communication error
63	Inverter error
64	Active filter error, PFC circuit error
65	Trip terminal Lerror
6A	Display PCB microcomputers communication error

Code	Description
71	Discharge temp. sensor error
72	Compressor temp. sensor error
73	Outdoor unit Heat Ex. liquid temp. sensor error
74	Outdoor temp. sensor error
75	Suction gas temp. sensor error
76	<ul style="list-style-type: none"> • 2-way valve temp. sensor error • 3-way valve temp. sensor error
77	Heat sink temp. sensor error
82	<ul style="list-style-type: none"> • Sub-cool Heat Ex. gas inlet temp. sensor error • Sub-cool Heat Ex. gas outlet temp. sensor error
83	Liquid pipe temp. sensor error
84	Current sensor error
86	<ul style="list-style-type: none"> • Discharge pressure sensor error • Suction pressure sensor error • High pressure switch error
94	Trip detection
95	Compressor rotor position detection error (permanent stop)
97	Outdoor unit fan motor error
98	Outdoor unit fan motor 2 error
99	4-way valve error
9A	Coil (expansion valve) error
A1	Discharge temp. error
A3	Compressor temp. error
A4	High pressure error
A5	Low pressure error
J2	Branch boxes error [Flexible Multi]

OUTDOOR UNIT Indicator PCB

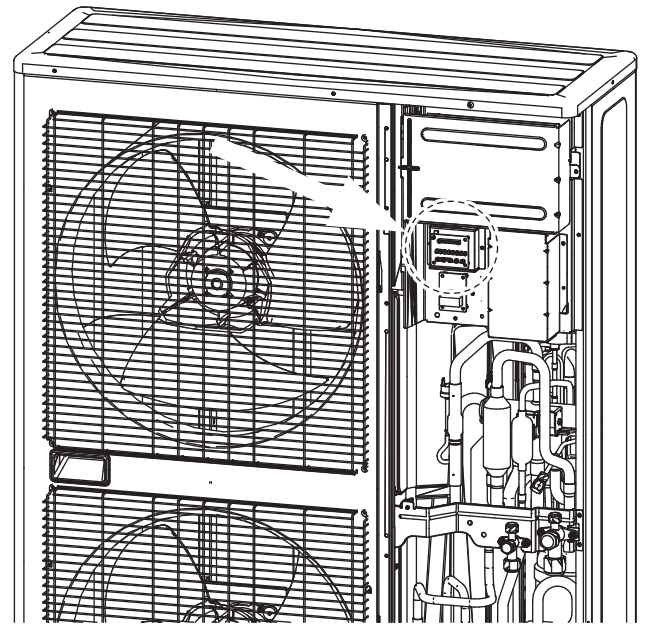
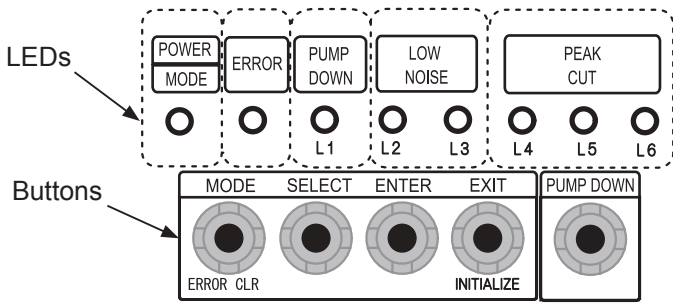

ERROR DETECTION

Display when an error occurs.

POWER MODE	ERROR	PUMP DOWN (L1)	LOW NOISE (L2) (L3)			PEAK CUT (L4) (L5) (L6)		
On	Blink (Hi speed)	Off	Off	Off	Off	Off	Off	Off

Check that the “ERROR” LED blinks, then press the [Enter] button once.
For details, refer to the following table.

DESCRIPTION	REMARK	LED display								
		POWER MODE	ERROR	PUMP DOWN (L1)	LOW NOISE (L2) (L3)		PEAK CUT (L4) (L5) (L6)			
Serial communication error	Serial forward transmission error immediately after operation	Blink (2 times)	On	Blink (1 time)	Blink (1 time)	Off	Off	On	On	On
	Serial forward transmission error during operation	Blink (2 times)	On	Blink (1 time)	Blink (1 time)	Off	On	Off	Off	Off
Indoor unit capacity error	Indoor unit capacity error	Blink (2 times)	On	Blink (2 times)	Blink (2 times)	Off	Off	Off	Off	On
Indoor unit error	Indoor unit error	Blink (2 times)	On	Blink (5 times)	Blink (15 times)	Off	Off	Off	Off	On
Outdoor unit main PCB error	Outdoor unit PCB model information error	Blink (2 times)	On	Blink (6 times)	Blink (2 times)	Off	Off	Off	Off	On
Inverter PCB error	Inverter error	Blink (2 times)	On	Blink (6 times)	Blink (3 times)	Off	Off	Off	Off	On
IPM error	Trip terminal L error	Blink (2 times)	On	Blink (6 times)	Blink (5 times)	Off	Off	On	On	On
Discharge temp. sensor error	Discharge temp. sensor 1 error	Blink (2 times)	On	Blink (7 times)	Blink (1 time)	Off	Off	Off	Off	On
Compressor temp. sensor error	Compressor temp. sensor 1 error	Blink (2 times)	On	Blink (7 times)	Blink (2 times)	Off	Off	Off	Off	On
Outdoor unit Heat Ex. sensor error	Heat Ex. centre temp. sensor error	Blink (2 times)	On	Blink (7 times)	Blink (3 times)	Off	Off	On	Off	Off
	Outdoor unit Heat Ex. liquid temp. sensor error	Blink (2 times)	On	Blink (7 times)	Blink (3 times)	Off	Off	On	On	On
Outdoor temp. sensor error	Outdoor temp. sensor error	Blink (2 times)	On	Blink (7 times)	Blink (4 times)	Off	Off	Off	Off	On
Heat sink temp. sensor error	Heat sink temp. sensor error	Blink (2 times)	On	Blink (7 times)	Blink (7 times)	Off	Off	Off	Off	On
Current sensor error	Current sensor 1 error (stoppage permanently)	Blink (2 times)	On	Blink (8 times)	Blink (4 times)	Off	Off	Off	Off	On
Pressure sensor error	High pressure switch 1 error	Blink (2 times)	On	Blink (8 times)	Blink (6 times)	Off	On	Off	Off	Off
	Pressure sensor error	Blink (2 times)	On	Blink (8 times)	Blink (6 times)	Off	On	On	On	Off
Trip detection	Trip detection	Blink (2 times)	On	Blink (9 times)	Blink (4 times)	Off	Off	Off	Off	On
Compressor motor control error	Rotor position detection error (stoppage permanently)	Blink (2 times)	On	Blink (9 times)	Blink (5 times)	Off	Off	Off	Off	On
Outdoor unit fan motor 1 error	Duty abnormal	Blink (2 times)	On	Blink (9 times)	Blink (7 times)	Off	Off	On	On	On
Outdoor unit fan motor 2 error	Duty abnormal	Blink (2 times)	On	Blink (9 times)	Blink (8 times)	Off	Off	On	On	On
4-way valve error	4-way valve error	Blink (2 times)	On	Blink (9 times)	Blink (9 times)	Off	Off	Off	Off	On
Discharge temp. 1 error	Discharge temp. 1 error	Blink (2 times)	On	Blink (10 times)	Blink (1 time)	Off	Off	Off	Off	On
Compressor temp. error	Compressor 1 temp. error	Blink (2 times)	On	Blink (10 times)	Blink (3 times)	Off	Off	Off	Off	On
Pressure error 2	Low pressure error	Blink (2 times)	On	Blink (10 times)	Blink (5 times)	Off	Off	Off	Off	On

OUTDOOR UNIT TEST RUN

Before the test run, refer to the figure and check the following items.

<input type="checkbox"/>	Is the outdoor unit securely installed?
<input type="checkbox"/>	Have you performed gas leakage inspection? (Connection joints of various pipes (flang connection, brazing))
<input type="checkbox"/>	Is the heat insulation done completely? (Gas pipe, liquid pipe, drain hose extension on indoor unit side etc)
<input type="checkbox"/>	Is the water discharging from drain without any problems?
<input type="checkbox"/>	Are the cables connected correctly?
<input type="checkbox"/>	Are the cables as per specifications?
<input type="checkbox"/>	Is the earth wire connected accurately?
<input type="checkbox"/>	Are there any obstacles blocking the suction gate, and outlet of the indoor/outdoor units?
<input type="checkbox"/>	Have you filled the specified amount of refrigerant?
<input type="checkbox"/>	Are the stop valves of gas pipe and liquid pipe fully open?
<input type="checkbox"/>	Has the power been supplied to crankcase heater for more than 6 hours?

If there are problems, adjust immediately and recheck.

Test run method

Be sure to configure test run settings only when the outdoor unit has stopped operating.

Depending on the communication status between the indoor and outdoor units, it may take several minutes for the system to start operating after settings for the test run are complete.

After the test run settings are complete, the outdoor units and the connected indoor units will start operating. Room temperature control will not activate during test operation (continuous operation).

If a knocking sound can be heard in the liquid compression of the compressor, stop the unit immediately and then energize the crank case heater for a sufficient length of time before restarting the operation.

Test run setting method (it can be performed in the following two ways)

Set with test run setting (refer to installation instructions manual of indoor unit for further details) available in the remote control.

Cooling Operation" and Heating Operation" can be set using , SELECT button and ENTER button available on the board of display unit.

(*Make sure to perform the first test run with cooling operation.)

Set as per the procedure given below.

Check items during test run

<input type="checkbox"/>	Is the outdoor unit making any abnormal noise or vibrating significantly?
<input type="checkbox"/>	Is the cold air or hot air blowing from indoor unit according to the operation mode?
<input type="checkbox"/>	Check that the "ERROR" LED blinks If it has displayed, check the error content as per 12.2. described later.
<input type="checkbox"/>	Operate the unit according to the operating manual provided with the indoor unit, and check that it is operating normally.

Setting method

- (1) Turn on the power of the outdoor unit and enter standby mode.

POWER	ERROR	PUMP DOWN	LOW NOISE			PEAK CUT	
MODE		(L1)	(L2)	(L3)	(L4)	(L5)	(L6)
On	Off	Off	Off	Off	Off	Off	Off

- (2) Press the ENTER button for more than 3 seconds.

POWER	ERROR	PUMP DOWN	LOW NOISE			PEAK CUT	
MODE		(L1)	(L2)	(L3)	(L4)	(L5)	(L6)
Blink	Off	Off	Off	Blink	Off	Off	Off

- (3) Press the SELECT button,
LED of the test run mode Switched between "COOL" and "HEAT".

Cooling test mode

POWER	ERROR	PUMP DOWN	LOW NOISE			PEAK CUT	
MODE		(L1)	(L2)	(L3)	(L4)	(L5)	(L6)
Blink	Off	Off	Off	Blink	Off	Off	Off

Heating test mode

POWER	ERROR	PUMP DOWN	LOW NOISE			PEAK CUT	
MODE		(L1)	(L2)	(L3)	(L4)	(L5)	(L6)
Blink	Off	Off	Blink	Off	Off	Off	Off

- (4) After confirm the operation mode, Press ENTER button.
The display changes as follows, and Air conditioner starts operation.

Cooling test mode

POWER	ERROR	PUMP DOWN	LOW NOISE			PEAK CUT	
MODE		(L1)	(L2)	(L3)	(L4)	(L5)	(L6)
Blink	Off	Off	Off	On	Off	Off	Off

Heating test mode

POWER	ERROR	PUMP DOWN	LOW NOISE			PEAK CUT	
MODE		(L1)	(L2)	(L3)	(L4)	(L5)	(L6)
Blink	Off	Off	On	Off	Off	Off	Off

- (5) Press [ENTER] button.
Air conditioner stopped operation.

POWER	ERROR	PUMP DOWN	LOW NOISE			PEAK CUT	
MODE		(L1)	(L2)	(L3)	(L4)	(L5)	(L6)
On	Off	Off	Off	Off	Off	Off	Off

OUTDOOR UNIT PUMP DOWN

⚠ WARNING

Never touch electrical components such as the terminal blocks except the button on the display board. It may cause a serious accident such as electric shock.

During the pump-down operation, make sure that the compressor is turned off before you remove the refrigerant piping.

Do not remove the connection pipe while the compressor is in operation with 2-way or 3-way valve open. This may cause abnormal pressure in the refrigeration cycle that leads to breakage and even injury.

⚠ CAUTION

Perform the pump down operation before disconnecting any refrigerant pipe or electric cable.

Collect refrigerant from the service port or the 3-way valve if pump down cannot be performed.

In case of a group control system installation, do not turn the power off pump down is completed in all outdoor units.
(Group control system installation described in SPECIAL INSTALLATION METHODS" in the installation manual of the indoor unit.)

- Operate [PUMPDOWN] button on the display board in the manner described below.

Preparation for pump down
Confirm that the power is off,
and then open the service panel.

Procedure

- Check the 3-way valves (both the liquid side and gas side) are opened.
- Turn the power on.

POWER	ERROR	PUMP DOWN	LOW NOISE			PEAK CUT		
MODE		(L1)	(L2)	(L3)	(L4)	(L5)	(L6)	
On	Off	Off	Off	Off	Off	Off	Off	

- Press [PUMP DOWN] button for 3 seconds or more after 3 minutes after power on.

POWER	ERROR	PUMP DOWN	LOW NOISE			PEAK CUT		
MODE		(L1)	(L2)	(L3)	(L4)	(L5)	(L6)	
On	Off	On	Off	Off	On	On	On	

LED display lights on as shown in the above figure and the fans and the compressor start operating.

- If the [PUMP DOWN] button is pressed while the compressor is operating, the compressor will stop, then start again in about 3 minutes.

- LED display will change as shown below about 3 minutes after the compressor starts. Fully close the 3-way valve on the liquid pipe side at this stage.

POWER	ERROR	PUMP DOWN	LOW NOISE			PEAK CUT		
MODE		(L1)	(L2)	(L3)	(L4)	(L5)	(L6)	
On	Off	On	Off	Off	Off	On	On	

- If the valve on the liquid pipe side is not closed, the pump down cannot be performed.

- When LED display changes as shown in the below figure close the 3-way valve on the gas pipe side tightly.

POWER	ERROR	PUMP DOWN	LOW NOISE			PEAK CUT		
MODE		(L1)	(L2)	(L3)	(L4)	(L5)	(L6)	
On	Off	On	Off	Off	Off	Off	On	

- if the valve on the gas pipe side is not closed, refrigerant may flow into the piping after the compressor stops.

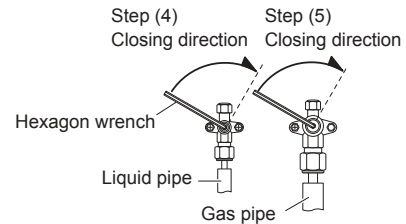

- LED display changes after 1 minute as shown in the figure below.

POWER	ERROR	PUMP DOWN	LOW NOISE			PEAK CUT		
MODE		(L1)	(L2)	(L3)	(L4)	(L5)	(L6)	
On	Off	On	Off	Off	Off	Off	Off	

Fans and compressor stop automatically.

- If the pump down is successfully completed (the above LED display is shown), the outdoor unit remains stopped until the power is turned off.

- Turn the power off.

POWER	ERROR	PUMP DOWN	LOW NOISE			PEAK CUT		
MODE		(L1)	(L2)	(L3)	(L4)	(L5)	(L6)	
Off	Off	Off	Off	Off	Off	Off	Off	

PUMP DOWN is completed.

(Note)

- To stop pump down, press the [PUMP DOWN] button again.
- To start the pump down again after the compressor is automatically stopped due to an error, turn the power off and open the 3-way valves. Wait 3 minutes, turn the power on and start the pump down again.
- When starting the operation after completion of the pump down, turn the power off, and then open the 3-way valves. Wait 3 minutes, turn the power on and perform a test run in the "COOL" operation mode.
- If an error occurs, recover the refrigerant from service port.

PARTS

INDOOR UNIT

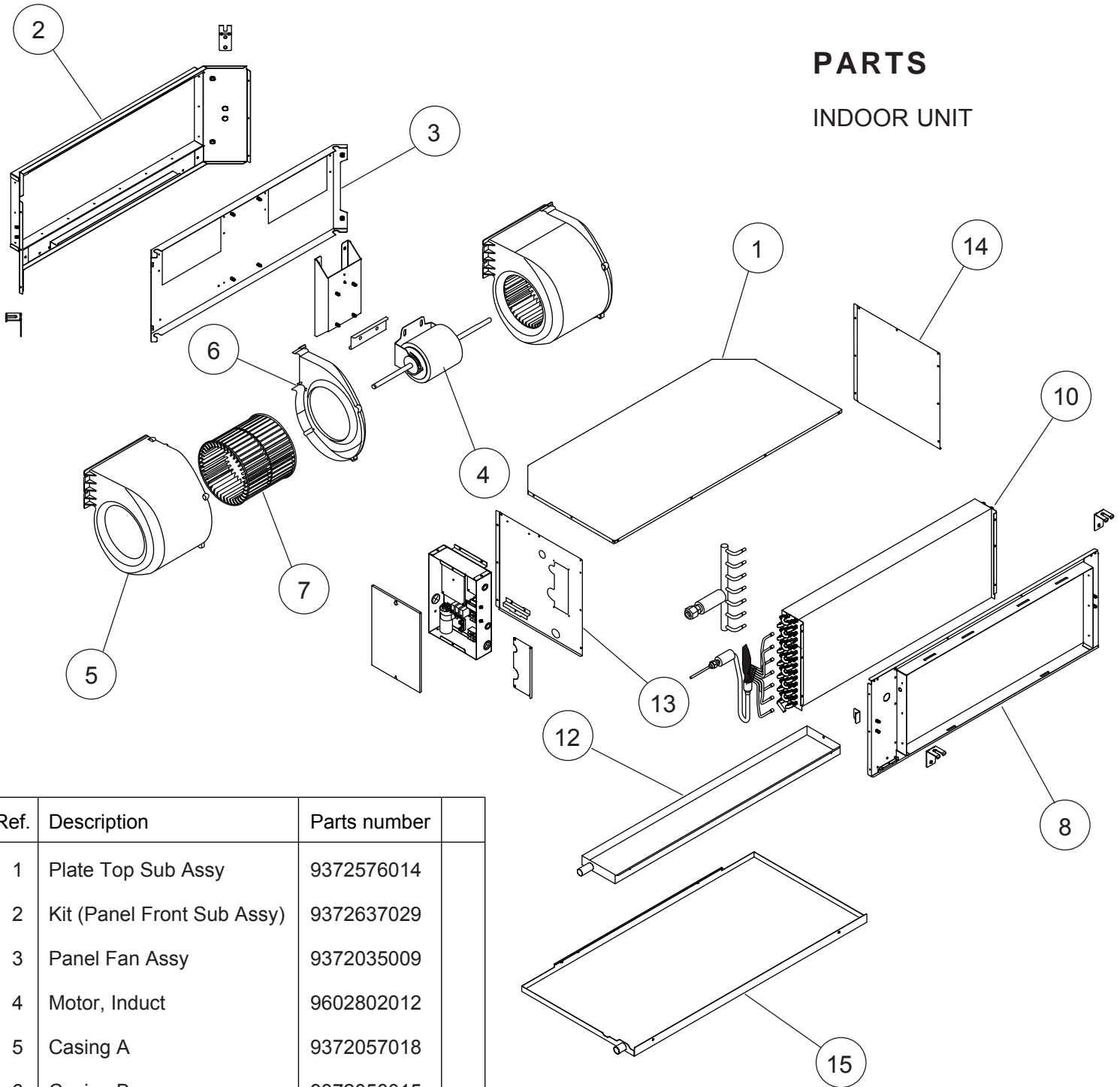

Ref.	Description	Parts number
1	Plate Top Sub Assy	9372576014
2	Kit (Panel Front Sub Assy)	9372637029
3	Panel Fan Assy	9372035009
4	Motor, Induct	9602802012
5	Casing A	9372057018
6	Casing B	9372058015
7	Sirocco Fan	9372059029
8	Kit (Panel Rear Sub Assy)	9372636022
9	Room Thermistor	9703299216
10	Evaporator Sub Assy	9372584057
11	Pipe Thermistor	9703297113
12	Drain Pan Assy	9372579015
13	Kit (Panel Right Sub Assy)	9372916025
14	Kit (Panel Left Sub Assy)	9372581018
15	Drain Pan S Sub Assy	9372582015

(Connector : white) (Connector : black)

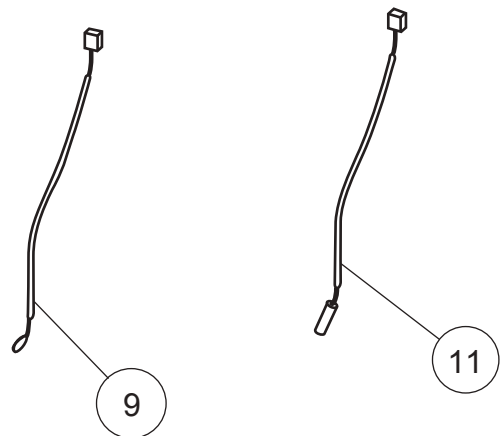

INDOOR UNIT

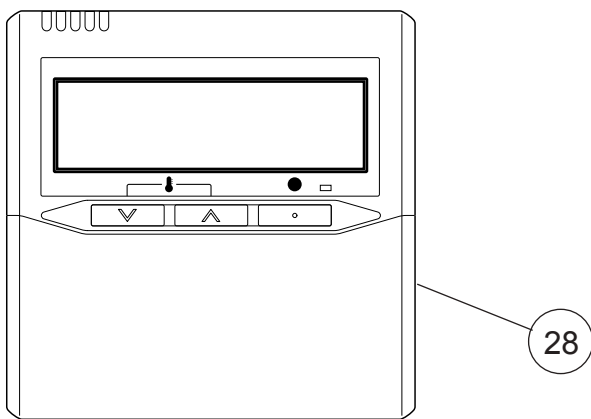
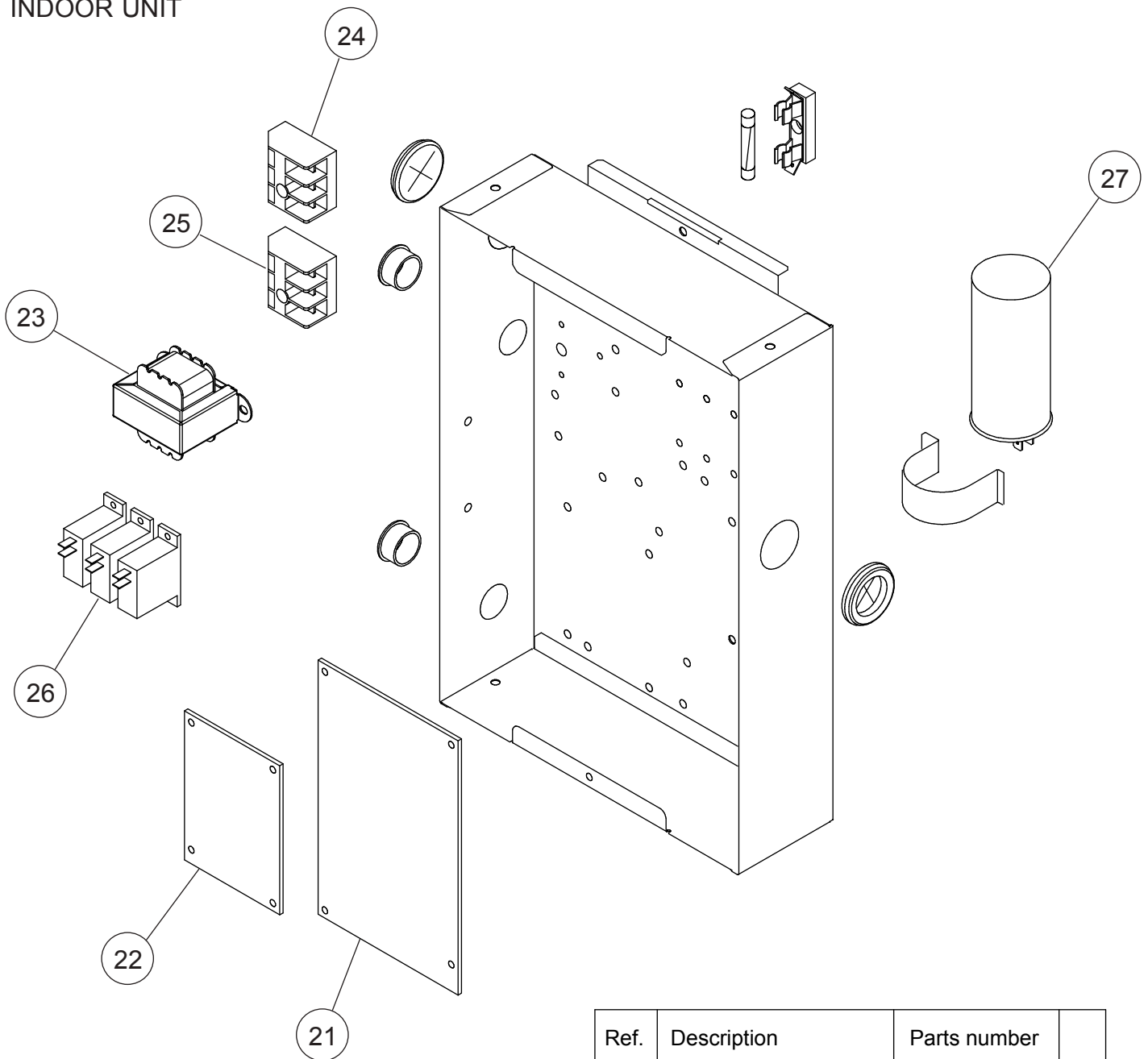

Ref.	Description	Parts number
21	Power Supply PCB	9705668119
22	Main PCB (45)	9705246287
22	Main PCB (54)	9705246294
23	Transformer (Power)	9704129017
24	Terminal 3P	9703345012
25	Terminal 3P	9306489045
26	Relay	9900294014
27	Capacitor, Plastic	9900269111
28	Remote Control	9318593013

PARTS

OUTDOOR UNIT

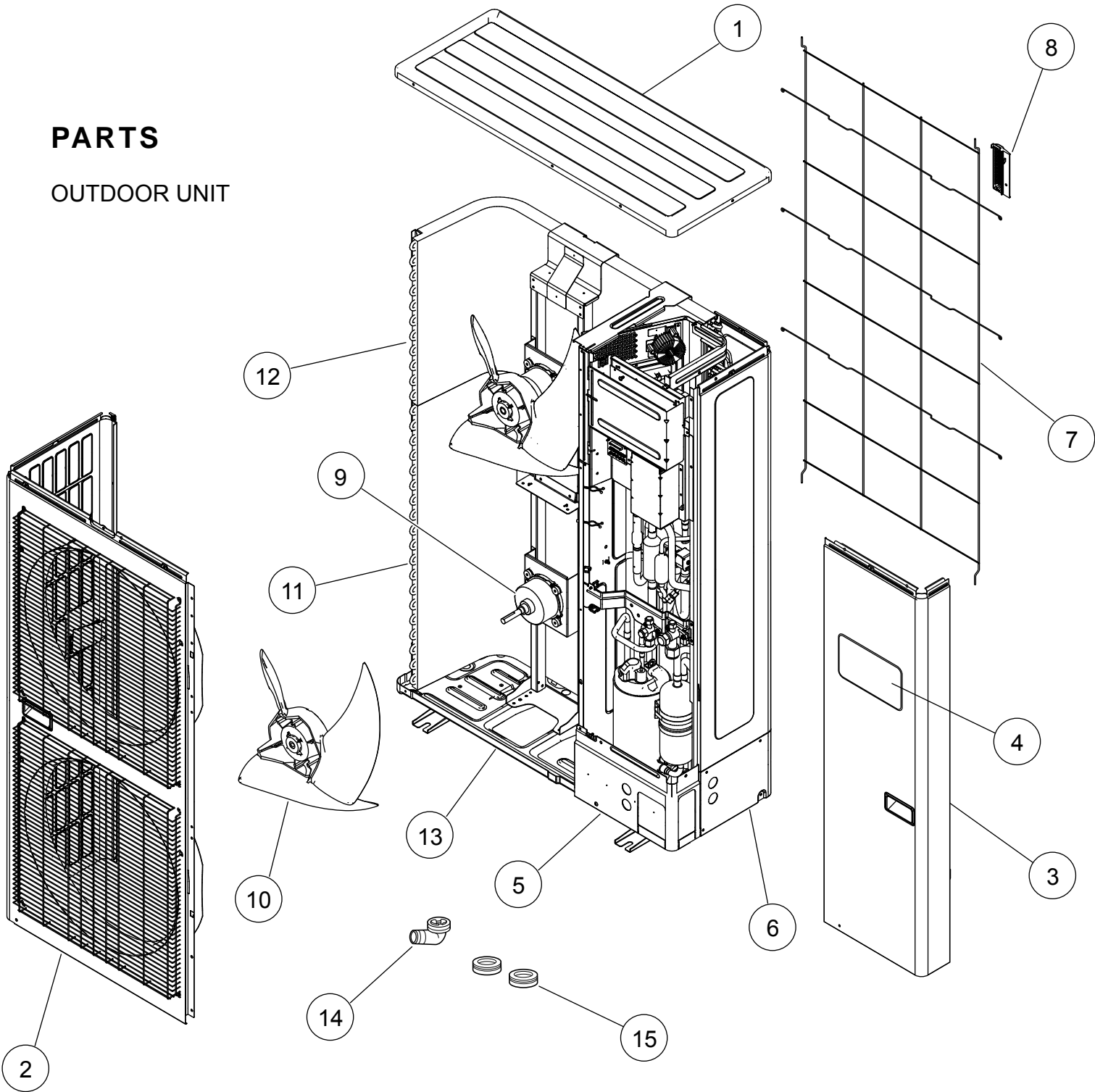

Ref.	Description	Parts number
1	Top Panel Sub Assy	9374417056
2	Front Panel Sub Assy	9374414109
3	Service Panel Sub Assy	9374415090
4	Emblem Rear	9351355005
5	Pipe Cover Front	9378861015
6	Right Panel Sub Assy	9374416189
7	Protective Net	9375381042
8	Thermo Holder	9375211011

Ref.	Description	Parts number
9	Motor DC Brushless	9602843039
10	Propeller Fan Assy	9366378020
11	Condenser A Sub Assy	9374420261
12	Condenser B Sub Assy	9374422081
13	Base Assy	9374166220
14	Drain Assy	9303029015
15	Drain Cap	313166024302

OUTDOOR UNIT
Control box

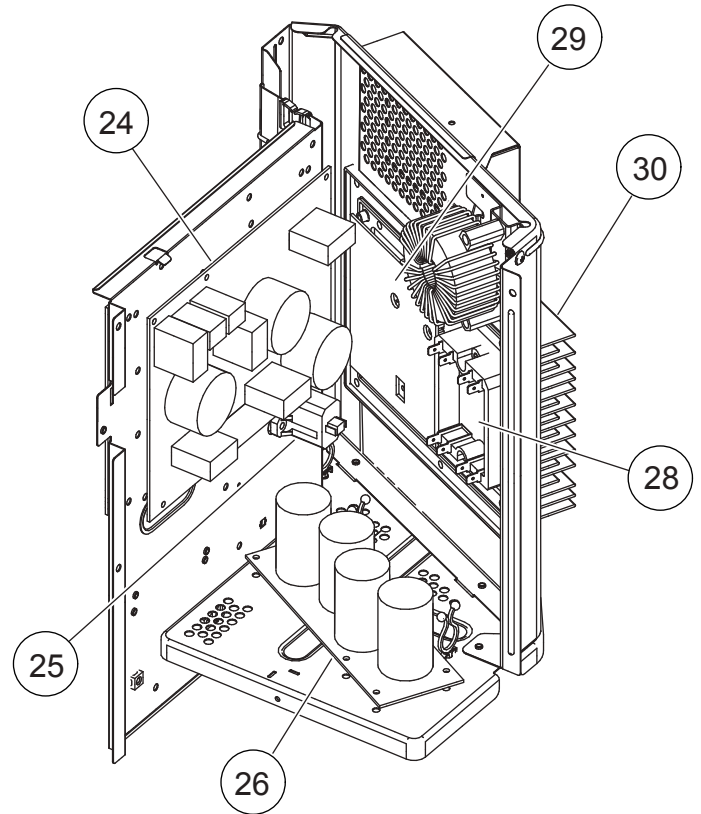
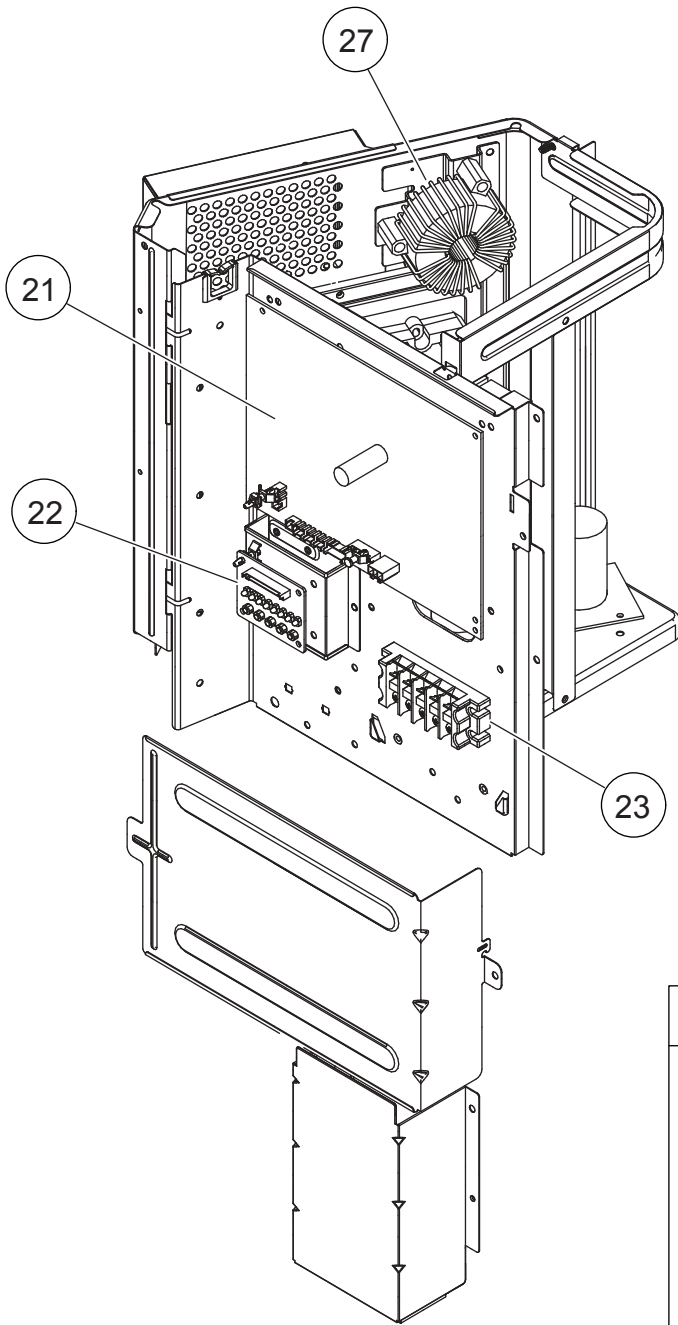

Ref.	Description	Parts number
21	Main PCB (AOYG45LETL)	9708690148
21	Main PCB (AOYG54LETL)	9708690155
22	Indicator PCB	9708678016
23	Terminal	9900203023
24	Filter PCB	9708688015
25	Thermistor	9704265012
26	Capacitor PCB	9707257083
27	Choke Coil	9900624019
28	ACTPM	9707592016
29	Transistor PCB	9708647043
30	Heat Sink	9380358008
--	Outdoor Thermistor	9900210069
--	Thermistor Assy (CN63)	9900599027
--	Thermistor Assy (CN62)	9900598013

OUTDOOR UNIT

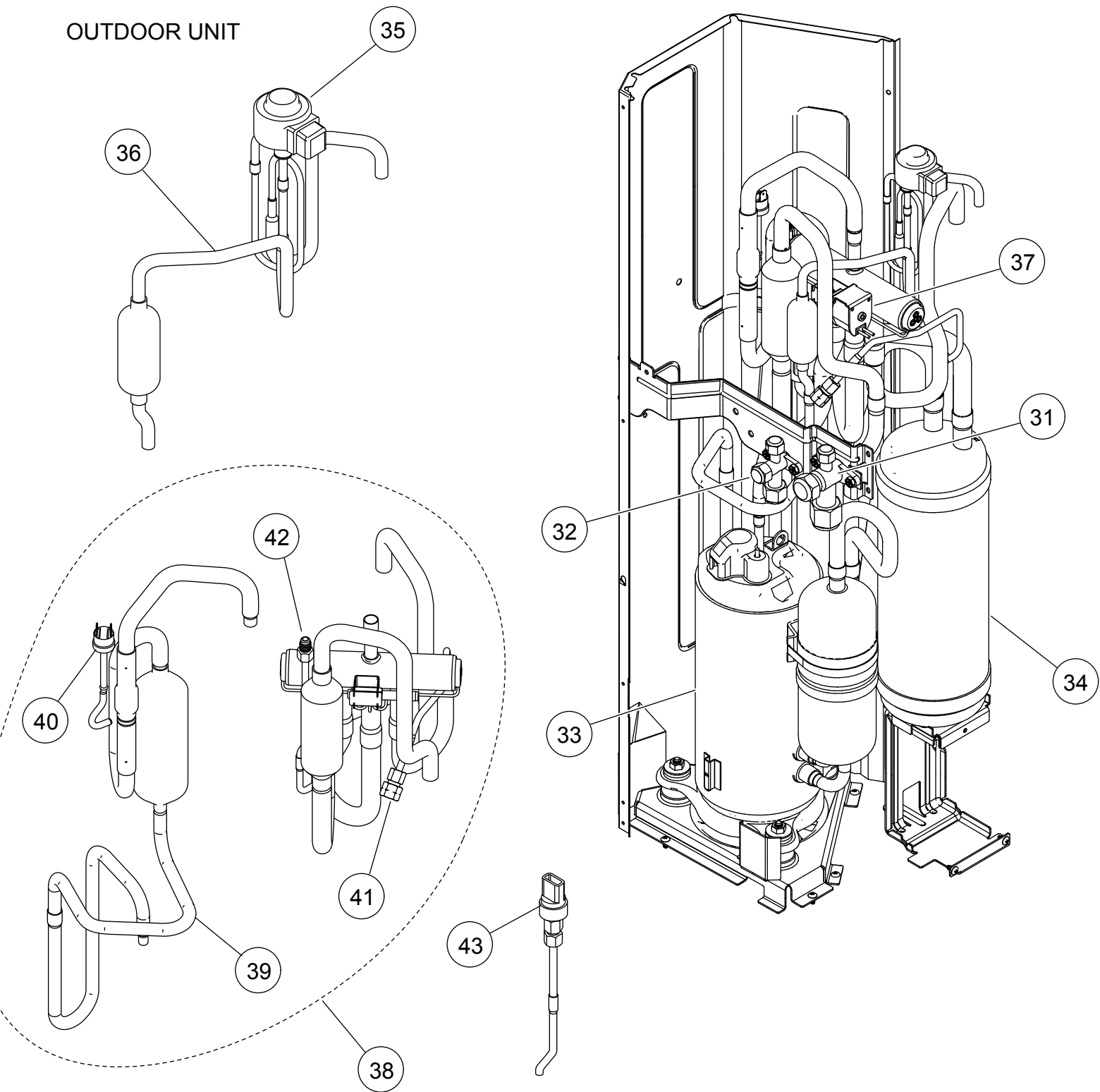







Ref.	Description	Parts number
31	3-way Valve Assy	9379079006
32	3-way Valve Assy	9379077002
33	Compressor	9810153005
34	Accumulator	9379014021
35	Expansion Valve Coil	9970096044
36	Expansion Valve Assy	9370947243
37	Solenoid	9970055072



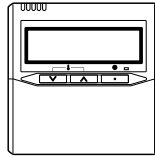
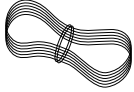

Ref.	Description	Parts number
38	4-way Valve Assy	9374425235
39	Discharge Pipe Assy	9371581248
40	Pressure Switch	9900186012
41	Check Joint Assy	9372802038
42	Union joint Assy	9379068000
43	Sensor	9900505080

ACCESSORIES

INDOOR UNIT

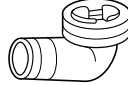
Name and Shape	Q'ty	Application	Part number
Special nut A (large flange) 	4	For suspending the indoor unit from ceiling	313005446653
Special nut B (small flange) 	4		313005446759
Coupler heat insulation (large) 	1	For indoor side pipe joint (large pipe)	9378173569
Coupler heat insulation (small) 	1	For indoor side pipe joint (small pipe)	9378173521
Cable tie 	1	Fixing the remote cord	313361275805
Remote control 	1	For air conditioner operation	9318593013
Remote control cord 	1	For connecting the remote control	9372714010
Tapping screw ($\varnothing 4 \times 16$) 	2	For installing the remote control	0700181108

OUTDOOR UNIT

Name and Shape	Q'ty	Application	Part number
Drain pipe 	1	For drain piping work	9303029015
Drain cap 	2		313166024302
Binder 	3	For binding power supply cable and connection cable	9374688012
One-touch bush 	2	For power supply cable and connection cable installation	9378779013

OPTIONAL PARTS

Parts name	Model name	Application
Simple remote control	UTY-RSN*M	For air conditioner operation
Wired remote control	UTY-RNN*M	For air conditioner operation
High functional wired remote control	UTY-RVN*M	
Remote sensor unit	UTY-XSZX	Room temperature sensor
External connect kit	UTD-ECS5A	For control input/output port
Long life filter	UTD-LF60KA	