

Outdoor unit

- WOYG160LJL
- WOYK150LJL
- WOYK170LJL

Hydraulic unit

- WSYG160DJ6
- WSYK170DJ9

INSTALLATION

WATERSTAGE

Air to Water Heat Pump Split single service



■ Installation and maintenance rules

The appliance must be installed and maintained by an approved professional in accordance with current regulations and codes of practice.

- **Warning, hydraulic unit should not be installed in an air current.**

■ Handling

The outdoor unit must not be placed in a horizontal position during transport.

If not kept upright during transport, the appliance could be damaged through displacement of the refrigerant and damage to the compressor suspension.

Any damage caused by transportation in a horizontal position is not covered by the warranty.

If necessary, the outdoor unit may be tilted only during manual handling (to go through a door or up a staircase). This operation must be conducted very carefully and the appliance must be immediately restored to the upright position.

■ Containment of refrigeration circuits

All refrigeration circuits are sensitive to contamination from dust and moisture. If such pollutants penetrate the refrigeration circuit, they can affect the reliability of the heat pump.

Make sure that the connections and refrigeration circuits (hydraulic unit, outdoor unit) are protected correctly.

In the event of a subsequent failure and following an inspection, the presence of moisture or foreign bodies in the compressor oil would automatically void the warranty.

- Check upon receipt that the fittings and refrigeration circuit caps mounted on hydraulic unit and outdoor unit are properly seated and secured (cannot be loosened with bare hands). If this is not the case, tighten them using a C spanner.
- Check also that the refrigeration connections are sealed (plastic caps or tubes crimped at the ends and brazed). If the caps must be removed during the installation (tubes to be re-cut for example), put them back as soon as possible.

■ Hydraulic connections

The connection must comply with industry standard practice according to current regulations.

Remember: Seal everything when fitting in accordance with industry standard practice for plumbing work:

- Use suitable seals (fibre gasket, O-ring).
- Use Teflon or hemp tape.
- Use sealing paste (synthetic depending on the case).

Use glycol/water mix if the minimum flow temperature is set below 10°C. If you are using a glycol/water mix, arrange for an annual check on the quality of the glycol. Use monopropylene glycol only. The recommended concentration is 30% minimum.

Never use monoethylene glycol.

- **In some installations, the presence of different metals can cause corrosion problems; the formation of metal particles and sludge can appear in the hydraulic circuit.**
- **In this case, it is advisable to use a corrosion inhibitor in the proportions indicated by the manufacturer.**
- **You must also ensure that treated water does not become corrosive.**





■ Electrical connections

- Before any maintenance operation, ensure that the general power supply is switched off.

• Specifications of electricity supply

The electrical installation must be carried out in accordance with prevailing rules.

Electrical connections will only be made once all other installation operations (fastening, assembly, etc.) have been completed.

Warning!

The contract signed with the energy provider must be sufficient not only to cover the heat pump's power requirements but also the combined sum of all the appliances likely to be operating at the same time. If the power is too low, check the power rating stated in your contract with your energy provider.

Never use a power socket for the power supply.

The heat pump must be supplied directly with power (without external switch) by special protected leads from the electric panel via dedicated bipolar circuit breakers, C curve for the outdoor unit, C curve for the electrical heating and domestic water backups (see tables page 35).

The electrical installation must be fitted with a 30mA RCD.

This appliance is designed to operate using a nominal voltage of 230 V or 400 V, +/- 10%, 50 Hz (depending on model).

• General remarks on electrical connections

It is essential to maintain neutral-phase polarity when making electrical connections.

Rigid wires are preferable for fixed installations, particularly in a building.

Tighten the cables using the cable glands to prevent the feed wires from being accidentally disconnected.

The earth connection and its continuity must be ensured.

• Cable glands

To ensure the stability of power (Low Voltage) and sensor (Extra-Low Voltage) cables, it is essential that the cable glands are tightened according to the following recommendations:

Size of cable gland (PE) (mm)	Diameter of cable (mm)	Cable gland tightening torque (check-nut) (N.m)	Coupling net tightening torque (N.m)
PG7	1 to 5	1.3	1
PG9	1.5 to 6	3.3	2.6
PG16	5 to 12	4.3	2.6

• Connecting to screw terminals

The use of ring, spade or blade terminals or caps is prohibited.

- Always select wire that complies with current standards.
- Bare the end of the wire to around 25 mm.
- With round end pliers, form a loop with a diameter which matches the tightening screws on the terminal.
- Tighten the terminal screw firmly onto the loop created. Insufficient tightening can cause overheating, leading to breakdown or even fire.

Rigid wires

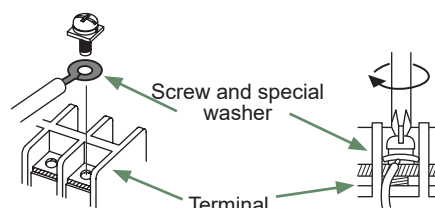
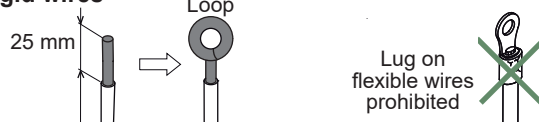

• Connecting to controller boards

- Remove the corresponding connector and make the connection.

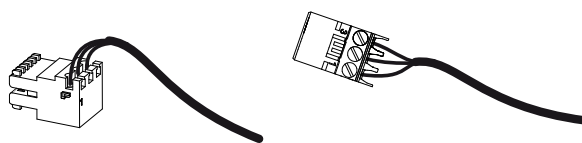

Pre-cabled bundle connector and/or screw connector

• Connecting to spring terminals

- Bare the end of the wire to around 12 mm.
- Push the spring with a screwdriver so that the wire enters the cage.
- Slide the wire into the opening provided for this purpose.
- Remove the screwdriver and then check that the wire stays gripped by the cage by pulling on it.

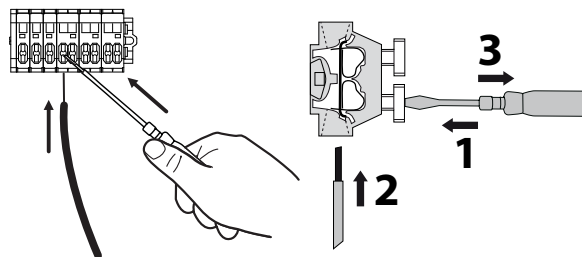









This appliance must be installed by qualified personnel holding a certificate of competence in the handling of refrigerants.

Contents

Q Description of the equipment	6
Packing	6
Unpacking and supplies	6
Definitions	6
Optional equipment	6
Operating Range	6
General characteristics	7
Description	12
Operating principle	14
🏠 Installation	16
Installation of refrigeration connections	16
Installation of the outdoor unit	18
Installation of the hydraulic unit	20
↻ Refrigeration connections	22
Rules and precautions	22
Shaping the refrigeration pipes	22
Checks and connection	25
Filling the installation with gas	26
💧 Hydraulic connections	30
Connecting the hydraulic unit to the heating circuit	30
Filling and bleeding the installation	31
Heating circulation pump speed settings	32
🔧 Electrical connections	34
Cable dimensions and protection rating	35
Electrical connections on the outdoor unit side	36
Electrical connections on the hydraulic unit side	38
Outside sensor	42
Room sensor (optional)	42
⚙️ Commissioning	44
🧑‍🔧 Controller Interface	46
User Interface	46
Display Description	47
Installer Menu	48
Navigating the Menus	48
Modifying Settings	49
Temperature control	50

 Controller Menu	52
Menu Structure	52
Installed options	53
Hydraulic configuration	53
Heat Pump Configuration	58
System status	60
Auxiliary functions	62
Settings	64
Easy Start	68
Basic Hydraulic Layout	70
Electrical Cabling Plans	72
 Fault Diagnosis	76
Faults in the Hydraulic Unit	76
Faults in the Outdoor Unit	77
 Maintenance of the installation	78
Hydraulic checks	78
Checking the outdoor unit	78
Electrical checks	78
 Other maintenance	79
Emptying the hydraulic unit	79
Distribution valve	79
 Quick-start procedure	80
Start-up check-list	80
Commissioning technical datasheet	82
 Instructions for the end user	83

Q Description of the equipment

► Packing

- **1 package** : Outdoor unit.
- **1 package** : Hydraulic unit and outside temperature sensor.

► Unpacking and supplies

While the courier is still present, carefully check the general appearance of the appliances and check that the outdoor unit has not been laid in a horizontal position.

In the event of a dispute, send any relevant reservations to the carrier in writing within 48 hours and send a copy of the letter to Customer Services.

► Definitions

- **Split**: The heat pump consists of two elements (an outdoor unit to be installed outdoors and a hydraulic unit to be installed inside the dwelling).
- **Air/water**: The surrounding air is the energy source. This energy is transmitted to the heating circuit water by the heat pump.
- **Inverter**: The fan and compressor speeds are modulated according to the heating requirements. This technology enables you to save on energy and operate on a single-phase power supply, whatever the heat pump's output, by avoiding pulling significant amounts of current at start-up.
- **COP** (Coefficient of Performance): This is the relationship between the energy transmitted to the heating circuit and consumed electrical energy.

Packing contents list

<i>Heat Pump</i>	<i>Outdoor unit</i>	<i>Hydraulic unit</i>
<i>Model</i>	<i>Reference</i>	<i>Code</i>
Waterstage SHP 16	WOYG160LJL	WSYG160DJ6
Waterstage SHP TRI 15	WOYK150LJL	WSYK170DJ9
Waterstage SHP TRI 17	WOYK170LJL	

► Optional equipment

- **Dual circuit kit** (code UTW-KZSXJ) for connecting 2 heating circuits.
- **Regulation extension kit** (code UTW-KREXD) to manage a 2nd heating circuit, swimming pool, telephone modem etc...
- **DHW kit** (code UTW-KDWXD) for connecting a mixed DHW tank (with built-in electrical backups).
- **Boiler connection kit** (code UTW-KBSXJ) for connecting a boiler to the heat pump.
- **Room thermostat** (code UTW-C55XA), **Wireless room thermostat** (code UTW-C58XD) for correcting the ambient temperature.
- **Remote control** (code UTW-C74TXF or UTW-C74HXF), **Wireless remote control** (code UTW-C78XD) for correcting the ambient temperature and programming the heat pump.
- **Cooling kit** (code UTW-KCLXD).
- **High flow rate circulation pump kit** (code UTW-PHFXG) for the installation of 1 underfloor heating circuit.

► Operating Range

This heat pump provides:

- Heating in winter,
- The management of electrical backups, for extra heating on the coldest days, or
- Installation with boiler connection* for extra heating on the coldest days,
- Management of two heating circuits*,
- Production of domestic hot water* (provided that it is combined with a mixed DHW tank),
- Cooling in summer* (for underfloor heating-cooling system or fan-convectors).

*: These options require the use of additional kits (see chapter "Required accessory" or "Optional equipment").

► General characteristics

Model name	Waterstage SHP	16	TRI 15	TRI 17
Rated heating performances (outdoor temp. / flow temp.)				
Heat output				
+7°C/+35°C - Underfloor heating system	kW	16.00	15.00	17.00
-7°C/+35°C - Underfloor heating system	kW	14.50	13.20	15.00
+7°C/+55°C - Radiator	kW	14.50	13.20	15.00
-7°C/+55°C - Radiator	kW	10.90	13.20	14.20
Power consumption				
+7°C/+35°C - Underfloor heating system	kW	3.86	3.46	4.10
-7°C/+35°C - Underfloor heating system	kW	5.27	4.55	5.32
+7°C/+55°C - Radiator	kW	5.58	4.77	5.49
-7°C/+55°C - Radiator	kW	5.89	6.77	7.40
Coefficient of performance (COP)	(+7°C/+35°C)	4.15	4.33	4.15
Electrical specifications				
Electrical voltage (50 HZ)	V	230	400	400
Maximum current for appliance	A	28	14	14
Nominal current	A	17.2	6.43	7.4
Maximum current of the Heating system electrical backup	A	26.1	39	39
Power of the Heating system electrical backup	kW	6 kW (single phase)	9 kW (3-phase)	9 kW (3-phase)
Circulation pump actual power consumption	W	39.5	39.5	39.5
Maximum power consumed by the outdoor unit	W	6300	6770	7400
Hydraulic Circuit				
Maximum operating pressure	MPa (bar)	0.3 (3)	0.3 (3)	0.3 (3)
Available heating pressure at nominal point +7°C / +55°C (Δt_8)	MPa (bar)	0.05 (0.5)	0.055 (0.55)	0.045 (0.45)
Minimum allowed hydraulic flow rate	l/h	600	600	600
Miscellaneous				
Weight of outdoor unit	Kg	137	138	138
Noise level at 5 m ¹ (Outdoor unit)	dB (A)	45	45	45
Sound power level in accordance with EN 12102 ² (Outdoor unit)	dB (A)	67	67	67
Weight of hydraulic unit (empty / full of water)	Kg	53 / 75	53 / 75	53 / 75
Hydraulic unit water capacity	l	30	30	30
Noise level at 1 m ¹ (Hydraulic unit)	dB (A)	37	37	37
Sound power level in accordance with EN 12102 ² (Hydraulic unit)	dB (A)	45	45	45
Heating system operating limits				
Outdoor temperature min/max	°C	-25 / +35	-25 / +35	-25 / +35
Max. heating water flow temperature underfloor heating	°C	45	45	45
Max. heating water flow temperature low temperature radiator	°C	60	60	60
Min. flow water temperature	°C	8	8	8
Refrigeration circuit				
Gas pipe diameters	Inches	5/8	5/8	5/8
Liquid Piping Diameters	Inches	3/8	3/8	3/8
Factory fill of refrigerant R410A ³	g	3800	3800	3800
Maximum operating pressure	MPa (bar)	4.15 (41.5)	4.15 (41.5)	4.15 (41.5)
Minimum / Maximum length of pipes ^{4/6}	m	5 / 15	5 / 15	5 / 15
Maximum length of pipes ⁵	m	30	30	30
Maximum level difference (Outdoor unit over hydraulic unit and heating only / Other cases)	m	25 / 15	25 / 15	25 / 15

¹ Sound pressure level at (x) m from the appliance, 1.5m off the ground, open field directionality 2.

² The sound power level is a laboratory measurement of the emitted sound power. It does not correspond to a measurement of the perceived sound power.

³ Refrigerant R410A as per NF EN 378.1 standard.

⁴ Filling with refrigerant R410A is done at the factory.

⁵ Taking into account a possible additional fill of refrigerant R410A (see "Additional filling", page 28).

⁶ The announced thermal and acoustic performances are measured with 7.5m length refrigerant lines.

- Waterstage SHP 16
- Waterstage SHP TRI 15
Waterstage SHP TRI 17

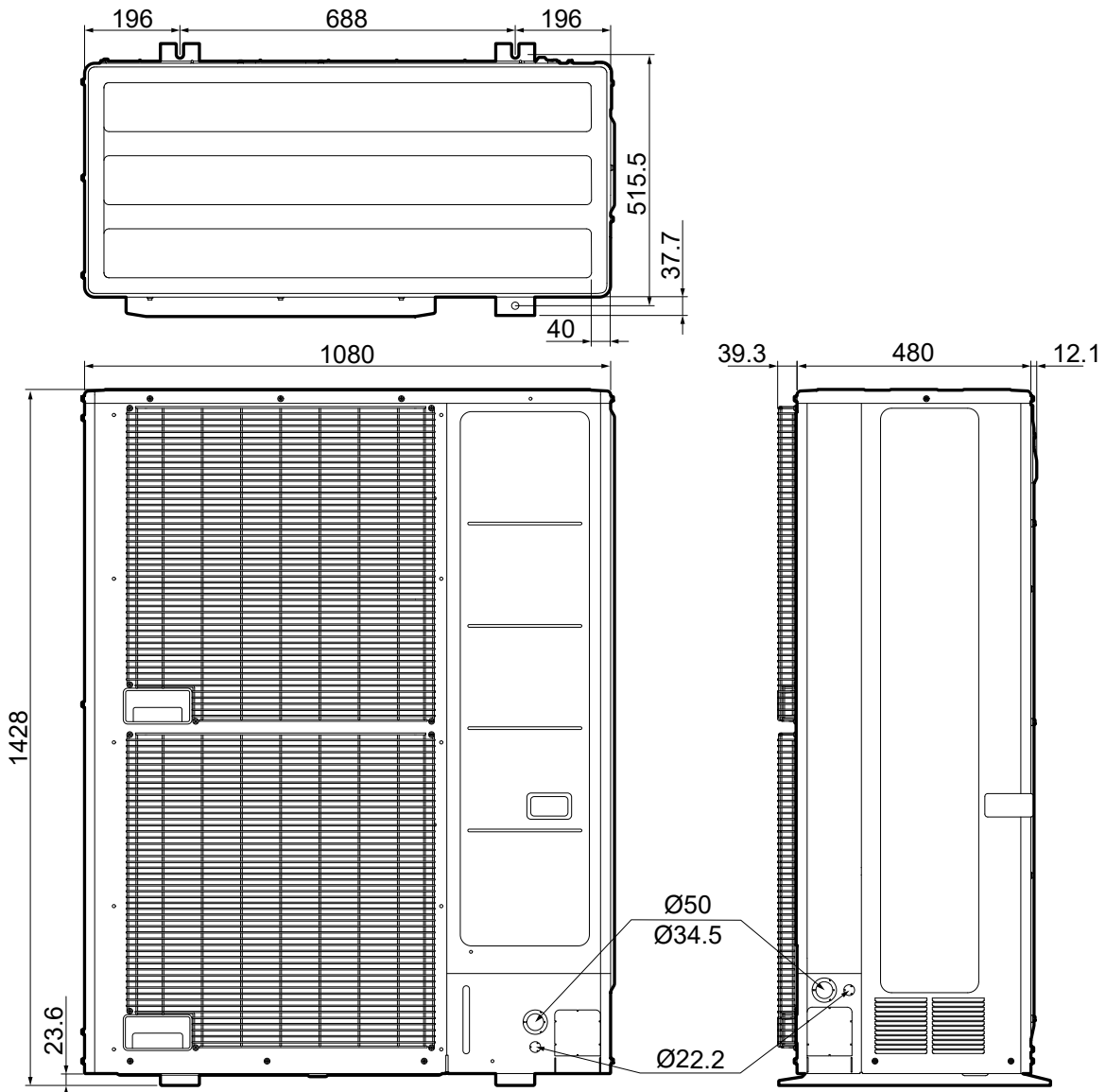
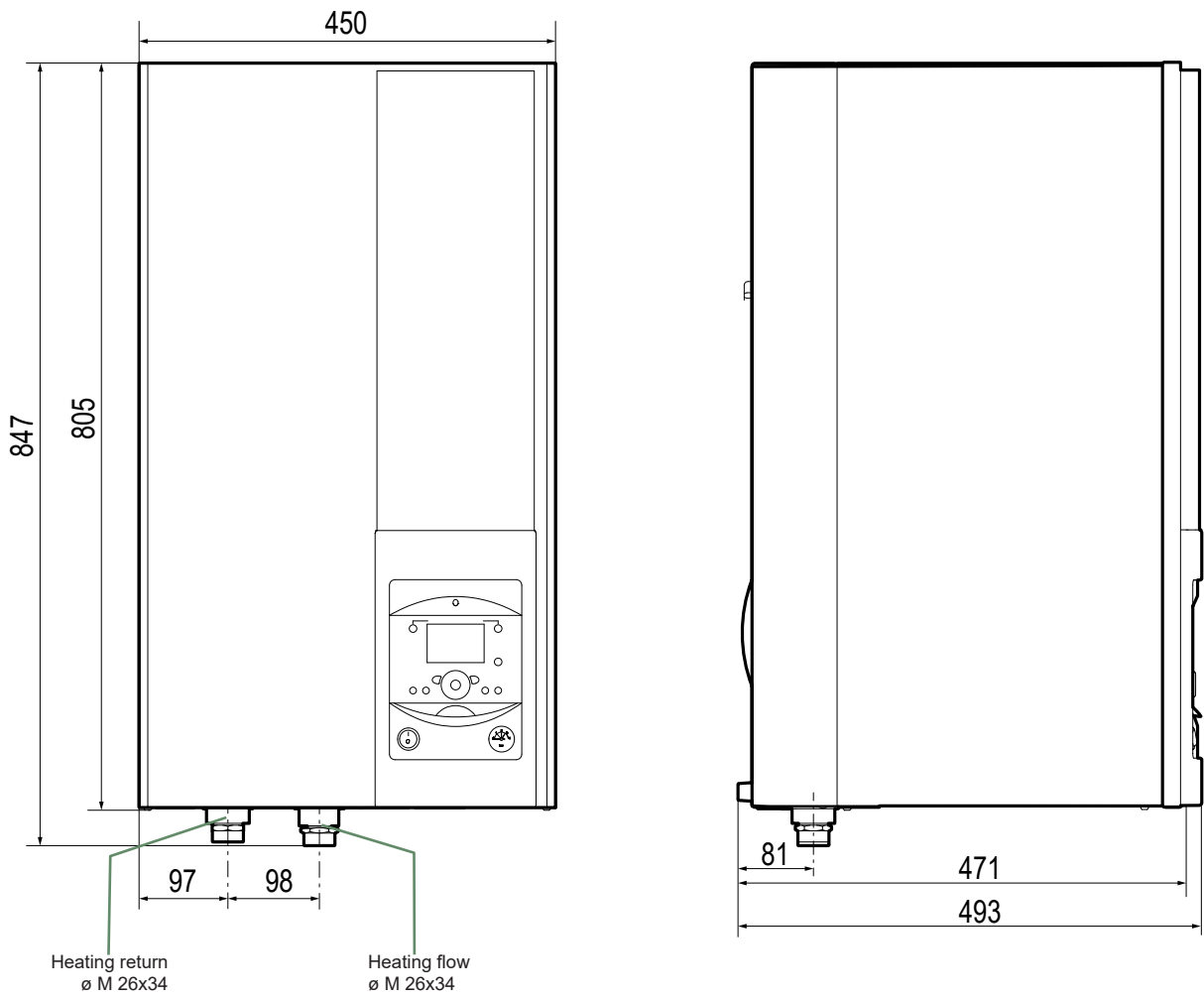

fig. 1 - Dimensions of outdoor units (in mm)

■ Hydraulic unit



Space requirements of the hydraulic unit, see page 20.

fig. 2 - Dimensions of hydraulic unit (in mm)

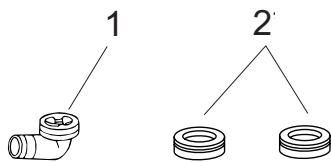

1	Elbow	for condensate evacuation.
2	Plugs (x9) (depending on model)	

fig. 3 - Accessories provided with the outdoor unit

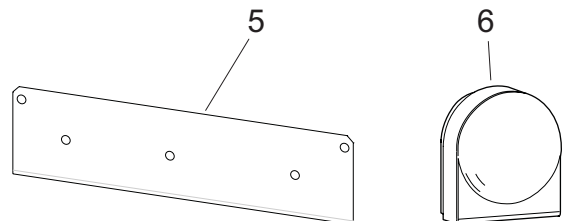

5	Bracket	for attaching hydraulic unit.
6	Outside sensor	to monitor the outdoor temp.

fig. 4 - Accessories provided with the hydraulic unit

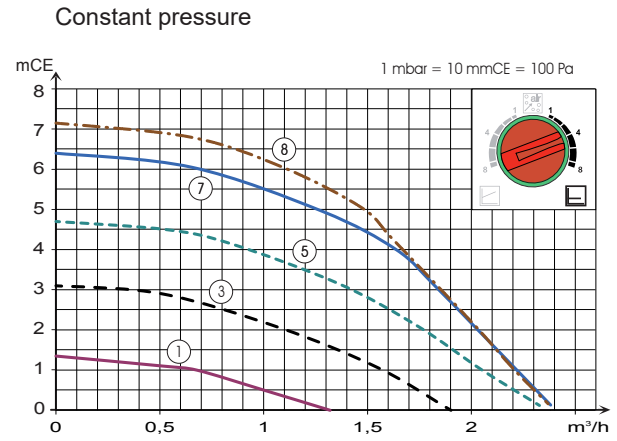
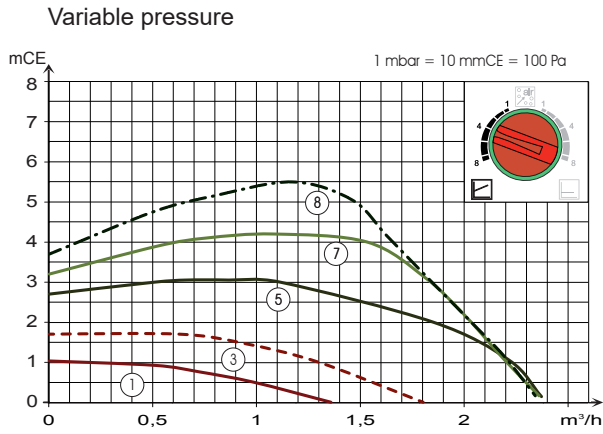

fig. 5 - Available hydraulic pressures and flow rates

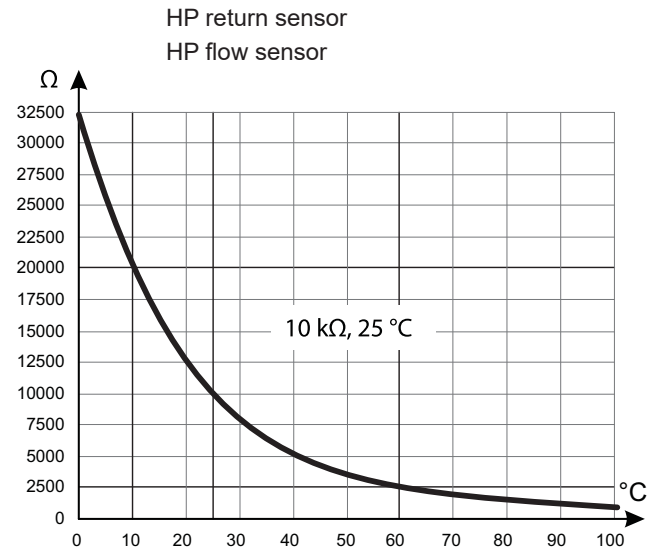
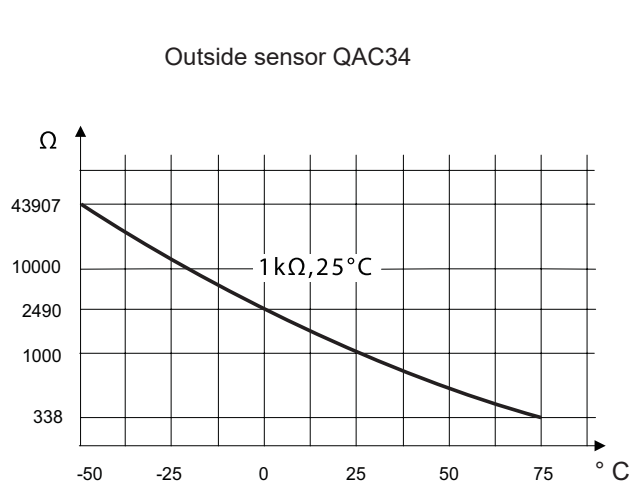

fig. 6 - Ohmic sensor values (Hydraulic unit)

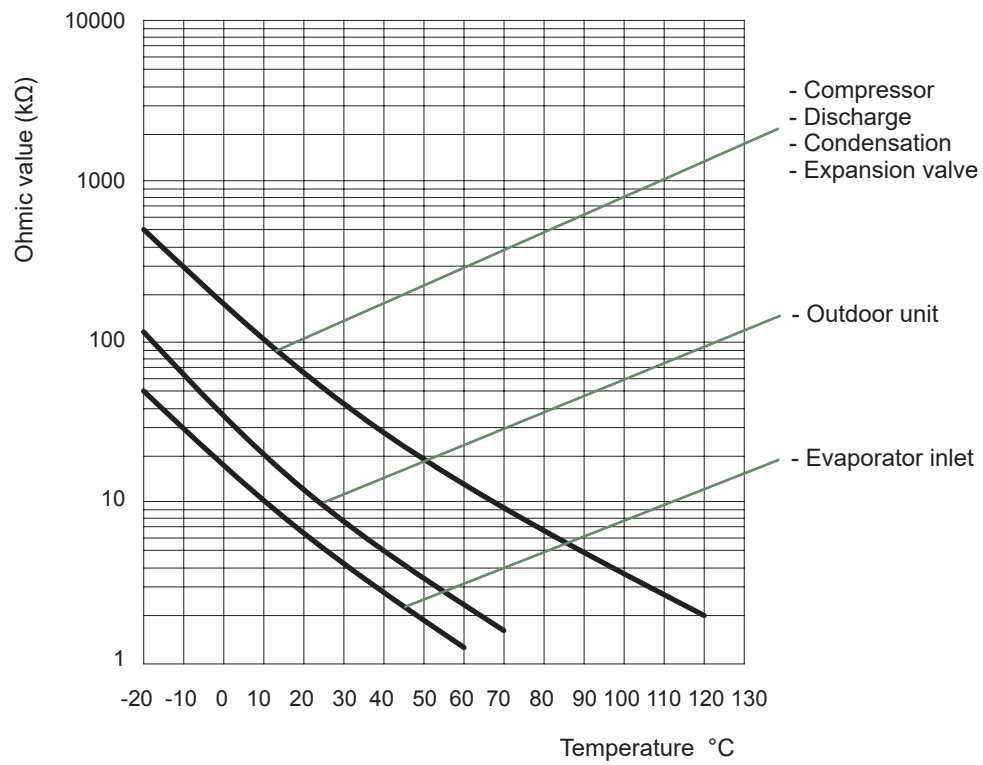
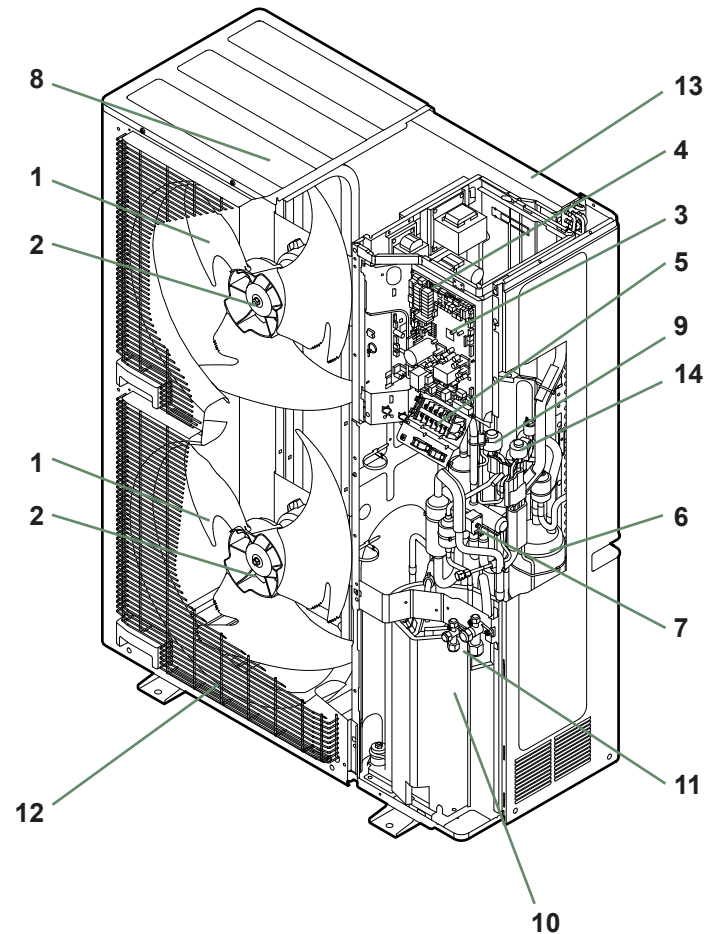

fig. 7 - Ohmic sensor values (Outdoor unit)

► Description

■ Waterstage SHP 16

■ Waterstage SHP TRI 15 Waterstage SHP TRI 17



Key:

1. High performance and low noise impeller.
2. Electrical motor with variable "Inverter" operation.
3. "Inverter" control unit.
4. Check lights and buttons.
5. Connection terminal blocks (power supply and interconnection).
6. Refrigerant storage bottle.
7. 4-way valve.
8. Anti-corrosion treated bodywork.
9. Main circuit electronic expansion valve.
10. Noise and thermally insulated "Inverter" compressor with liquid injection port.
11. Refrigeration connection valves (flared connectors) with protective caps.
12. Holding tank with condensate drain hole.
13. High-performance exchange surface evaporator; anti-corrosion treated hydrophilic aluminium fins and grooved copper tubes.
14. Solenoid valve for liquid injection.

fig. 8 - Outdoor unit components

■ Hydraulic unit

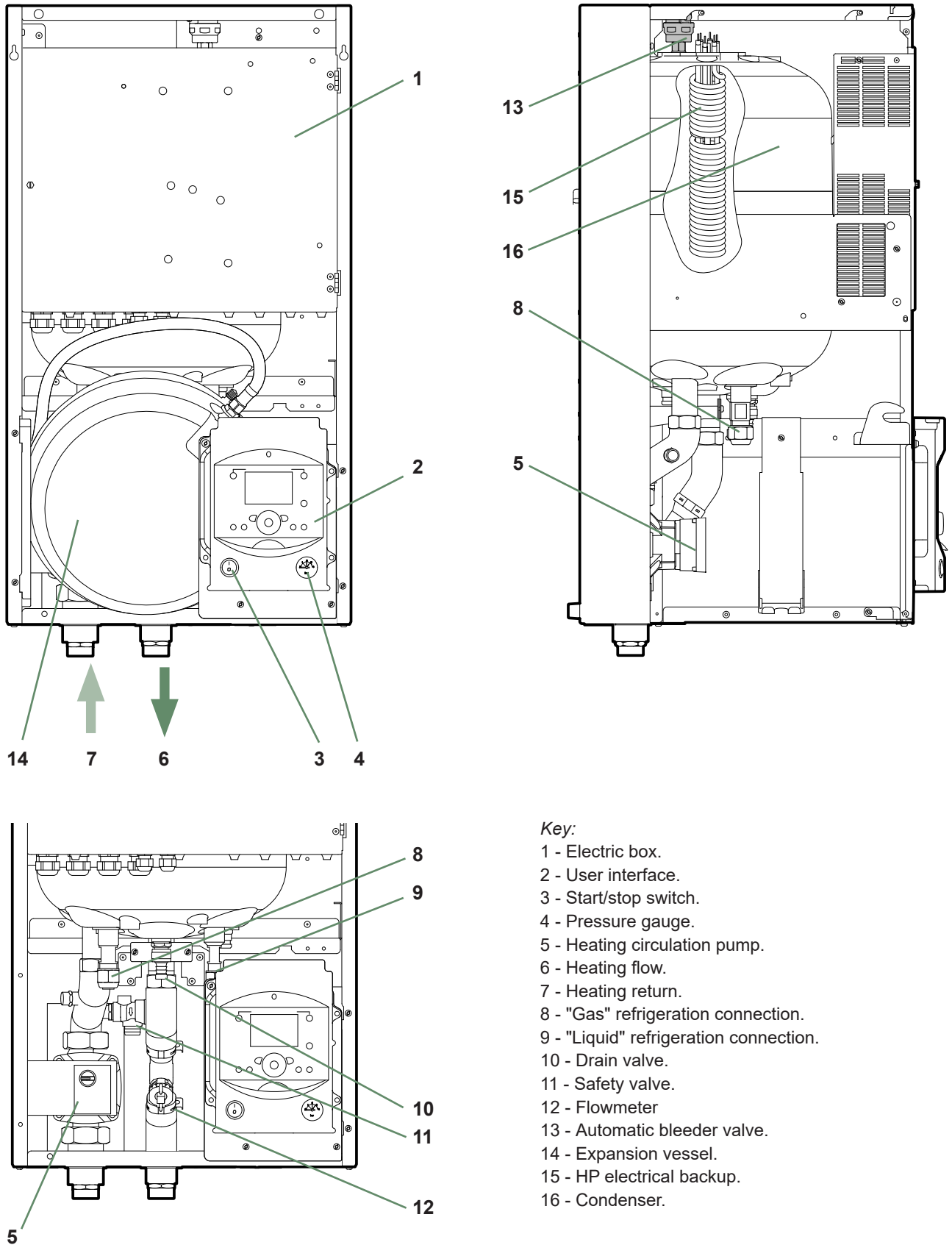

- Key:
- 1 - Electric box.
 - 2 - User interface.
 - 3 - Start/stop switch.
 - 4 - Pressure gauge.
 - 5 - Heating circulation pump.
 - 6 - Heating flow.
 - 7 - Heating return.
 - 8 - "Gas" refrigeration connection.
 - 9 - "Liquid" refrigeration connection.
 - 10 - Drain valve.
 - 11 - Safety valve.
 - 12 - Flowmeter
 - 13 - Automatic bleeder valve.
 - 14 - Expansion vessel.
 - 15 - HP electrical backup.
 - 16 - Condenser.

fig. 9 - Hydraulic unit components

► Operating principle

The heat pump transmits the energy contained in the surrounding air into the dwelling to be heated.

The heat pump consists of four main elements, in which a refrigerant (R410A) circulates.

- In the evaporator (ref. **13**, fig. 8, page 12): The calories are taken from the outside air and transmitted to the refrigerant. Because it has a low boiling point, it changes from a liquid to a vapour, even in cold weather (down to -25°C outside temperature).
- In the compressor (ref. **10**, fig. 8, page 12): The vaporised refrigerant is pressurised and takes on even more calories.
- In the condenser (ref. **14**, fig. 9, page 13): The energy of the refrigerant is transmitted to the heating circuit. The refrigerant returns to its liquid state.
- In the expansion valve (ref. **9**, fig. 8, page 12): The liquefied refrigerant is returned to a low pressure and regains its initial temperature and pressure.

The heat pump is equipped with a controller which controls the room temperature based on the outdoor temperature measurement. The room thermostat (option) provides a corrective action for the temperature control.

The hydraulic unit is fitted with an electrical backup or boiler connection which intervenes to provide additional heat during the coldest periods.

• Control functions

- The heating circuit's flow temperature is controlled by the temperature control.
- Depending on the heating flow temperature, the outdoor unit's power is modulated by the "Inverter" compressor.
- Control of the backup electrical heating.
- The daily timer program is used to set the periods where the ambient temperature is comfortable or reduced.
- Summer/winter time mode switchover is automatic.
- Management of the boiler backup*.
- Room sensor*: The room sensor provides a corrective action for the temperature control.
- Control of a second heating circuit*.
- Domestic hot water*: Heating timer program.
- Managing cooling*.

* Where the heat pump is fitted with options and associated kits.

• Protective functions

- Anti-legionella cycle for domestic hot water.
- Frost protection: Frost protection cuts in if the heating circuit's flow temperature falls below 5°C (provided that the heat pump's electrical power supply is not interrupted).

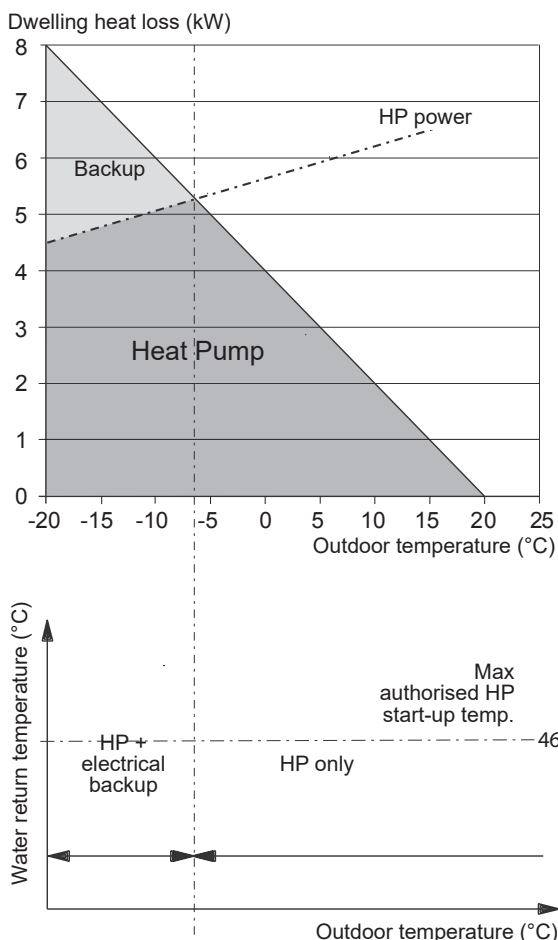

fig. 10 - Examples and operating limits

• **Domestic hot water (DHW) operating principle**

Two domestic hot water (DHW) temperatures can be set: comfort and reduced.

The default DHW program is set to the comfort temperature between 00:00 and 05:00 and between 14:30 and 17:00 and to the reduced temperature for the rest of the day. This optimises electrical consumption while ensuring comfortable heating and water temperatures.

The reduced temperature setpoint may be useful to avoid restarting the DHW too often and for too long during the day.

The production of domestic hot water (DHW) is started when the temperature in the tank drops to 7°C below the temperature setpoint.

The heat pump produces the domestic hot water, which is then additionally heated, if required, by the tank's electrical backup or by the boiler. To ensure a DHW setpoint over 55°C, the electrical backup heating must be left on.

Depending on the setting, the comfort temperature can be reached 24h/day or only at night or following the DHW program.

If the contract signed with the energy provider includes a day/night tariff, the electrical backup is subject to the supplier's power tariff and the comfort temperature may only be reached at night.

If no particular contract has been signed, the comfort temperature can be reached at any time, including during the day.

The production of DHW takes priority over heating; nevertheless the production of DHW is managed by cycles that regulate the amount of time assigned to heating and production of DHW in the event of simultaneous demand.

Anti-legionella cycles can be programmed.

• **Fan convectors with integrated control system**

Do not use a room sensor in the area in question.

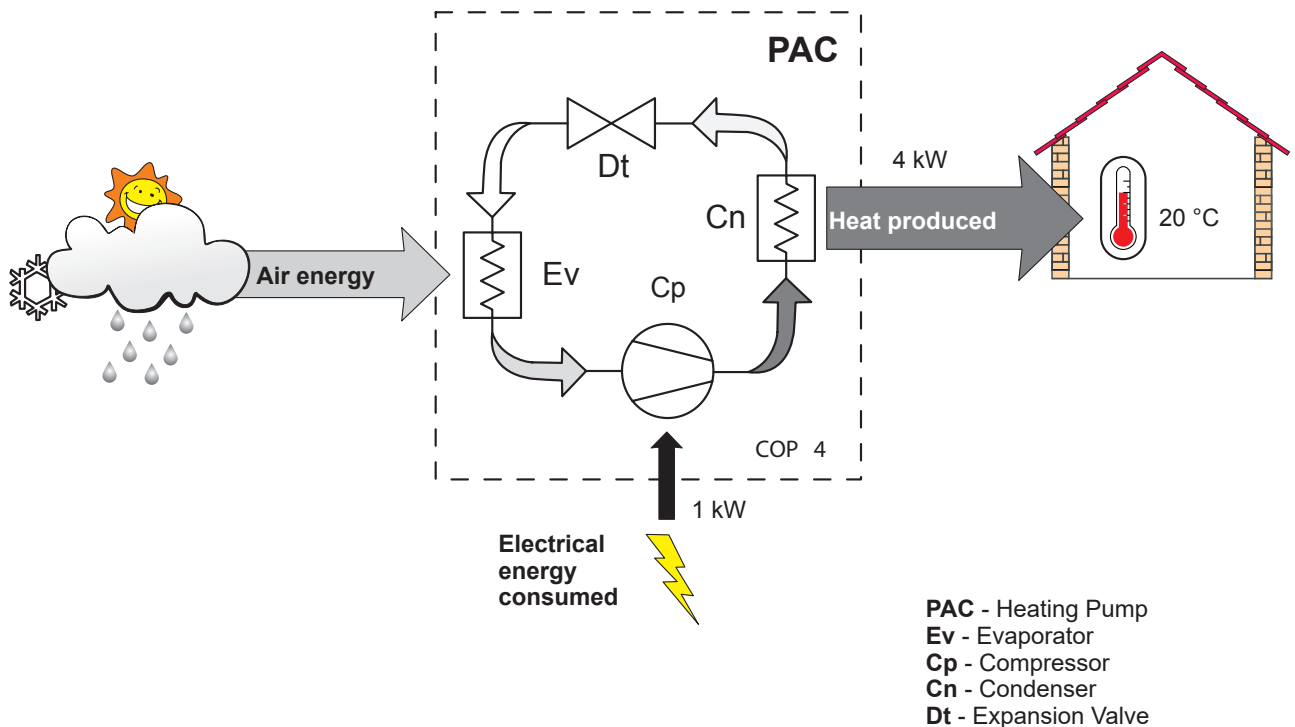

fig. 11 - Heat pump operating principle

🏠 Installation

▶ Installation of refrigeration connections



Bend the pipes into position and make holes for them through the floor or walls either with their protective caps in place or after brazing.

Keep the protective caps in place or ends brazed until the appliance is commissioned.

The outdoor unit must be connected to the hydraulic unit **only with brand new separately insulated copper connections** (refrigerant quality).

Maintain the same pipe diameters (fig. 19).

Observe the maximum and minimum distances between the hydraulic unit and the outdoor unit (fig. 19, page 24); the guarantee of performance and the service lifespan of the system depend on this.



The minimum length of the refrigeration connections for correct operation is 5 m.

The appliance's warranty will be void if it is operated with refrigeration connections less than 5 m long (tolerance +/- 10%).

If the refrigeration connections are exposed to weathering or UV radiation and the insulation is not resistant, protection must be provided.

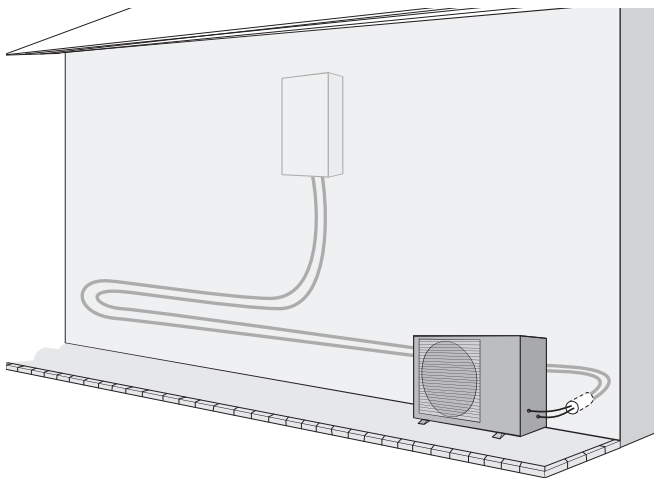

fig. 12 - Example of recommendation for layout of refrigeration connections



A series of horizontal dotted lines spanning the width of the page, providing a guide for handwriting practice.

► Installation of the outdoor unit

▼ Installation precautions



The outdoor unit must only be installed outside. If a shelter is required, it must have broad openings on all 4 sides and installation clearances must be observed.

- Choose the location of the appliance after discussion with the client.
- We recommend choosing a site that is sunny but sheltered from strong cold prevailing winds.
- The unit must be easily accessible for future installation and maintenance work (page 20).
- Ensure that connections to the hydraulic unit can be made easily.
- The outdoor unit is able to withstand bad weather but avoid installing it in a position where it is likely to be exposed to significant dirt or flowing water (under a defective gutter for example).

- Water may flow out of the outdoor unit when it is operating. Do not install the unit on a paved terrace; choose a well-drained location (e.g. gravel or sand). If installation is carried out in an area where the temperature stays below 0°C for long periods, check that the presence of ice does not present any danger. A drainage pipe can also be connected to the outdoor unit (see fig. 14).
- Nothing should obstruct the air circulation through the evaporator and out from the fan (fig. 13).
- Keep the outdoor unit away from heat sources and flammable products.
- Make sure that the unit does not disturb the surrounding area or inhabitants (noise level, draught, low temperature of the ejected air freezing the plants in its path).

A ≥ 80 mm	F ≥ 600 mm
B ≥ 100 mm	G ≥ 1000 mm
C ≥ 200 mm	H ≥ 1500 mm
D ≥ 300 mm	J ≥ 2000 mm
E ≥ 500 mm	K ≥ 3000 mm

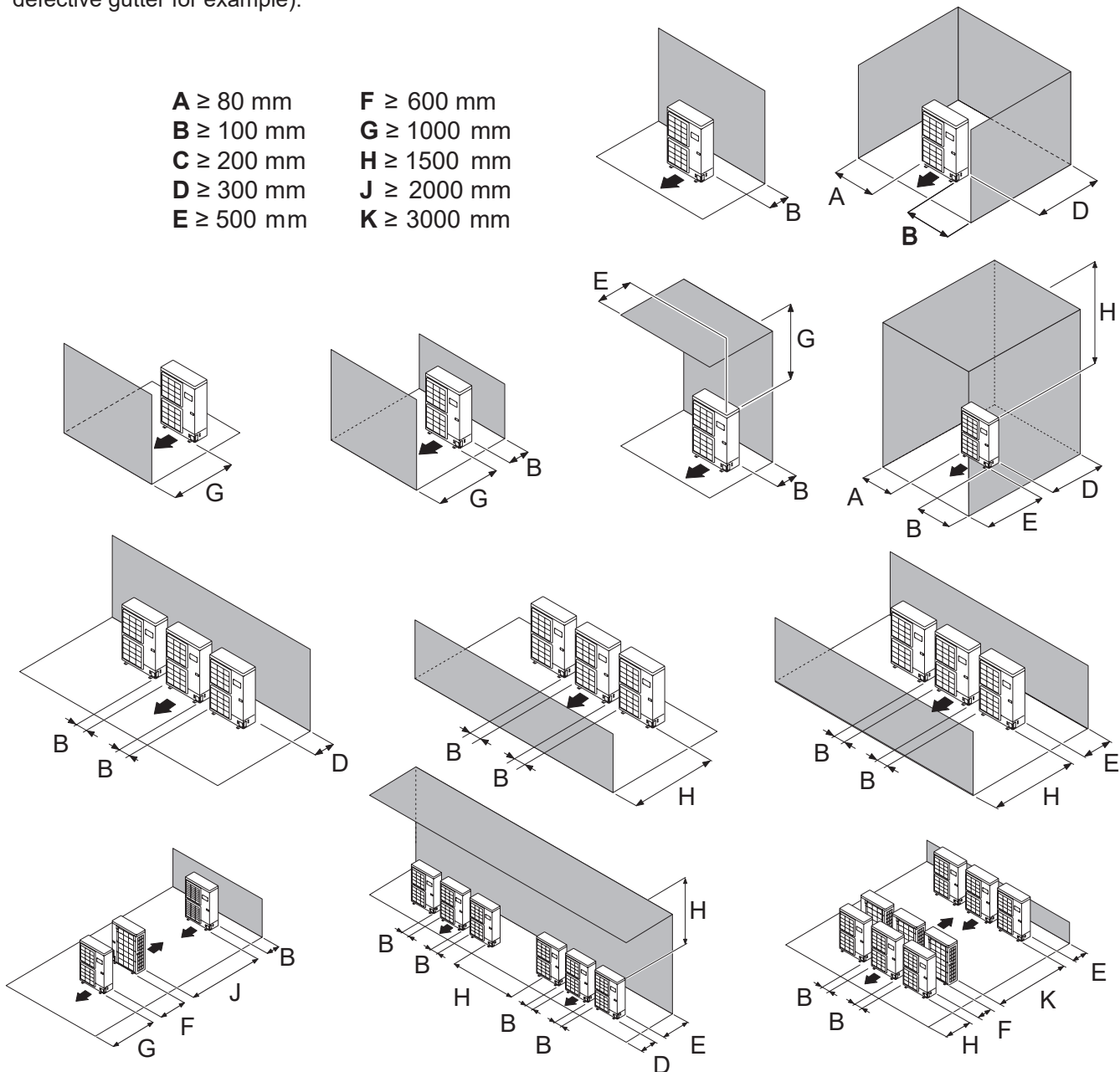

fig. 13 - Minimum installation clearances around the outdoor unit (all models)

- The surface on which the appliance is installed must:
 - Be permeable (soil, gravel, etc.).
 - Support its weight easily.
 - Allow a solid fastening base,
 - Not transmit any vibration to the dwelling. Anti-vibratory blocks are available as an option.
- The wall bracket cannot be used where it is likely to transmit vibrations. Installing the unit on the ground is preferred.

▼ Positioning Outdoor Unit

The outdoor unit must be raised at least 50 mm above ground level. In areas prone to snow, this height should be increased but should not exceed 1.5 m (figure 12).

- Fasten the outdoor unit by means of screws and rubber tightening or toothed lock washers to prevent them from coming loose.

In areas with heavy snowfall, if the intake and outlet of the outdoor unit is blocked with snow, heating may become difficult and a failure is likely to occur.



Construct a canopy or place the unit on a high stand (local configuration).

- Place the unit on a solid stand in order to minimise impacts and vibrations.
- Do not place the unit directly on the ground as this will cause problems.

▼ Condensate drain pipe

The outdoor unit can generate a large volume of water (called condensate).



If the use of a drain pipe is necessary:

- Use the elbow provided (C) and connect a 16 mm-diameter hose for draining the condensate.
- Use the plug(s) provided (B) to block the opening of the condensate drain pan.

Allow for the condensate to flow away under the force of gravity (waste water, rain water, gravel bed).

If installation is carried out in an area where the temperature stays below 0°C for long periods, equip the drain pipe with trace heating to avoid it icing up. Trace heating must heat not only the drain pipe but also the bottom of the appliance's condensate collection tank.

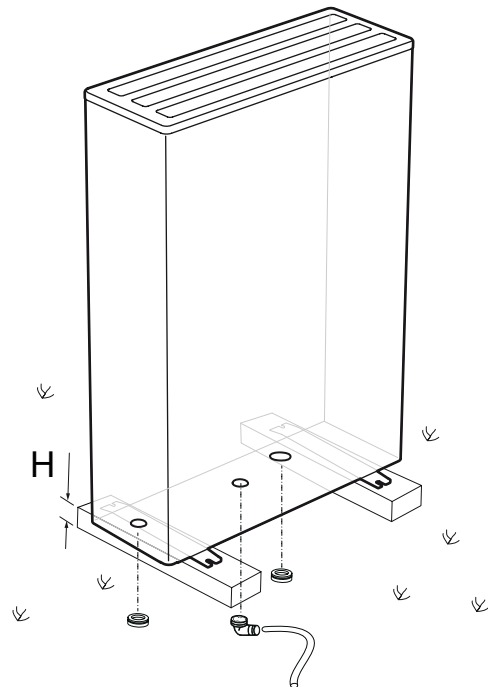

* In areas with heavy snowfall, (H) must be higher than the average snow layer.

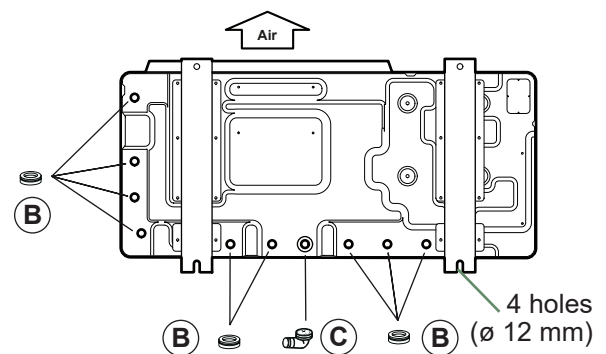
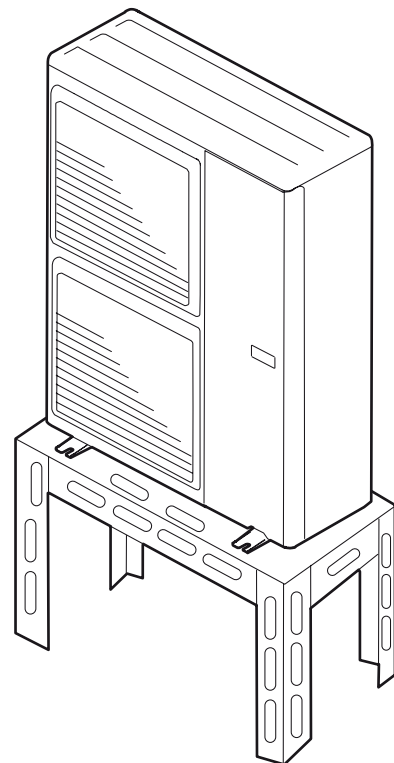
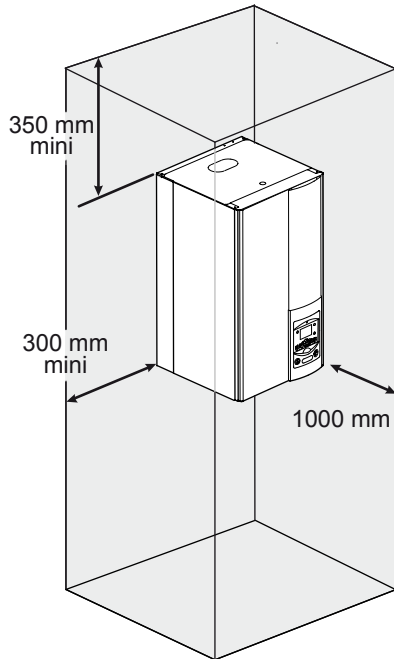

fig. 14 - Installation of the outdoor unit evacuation of condensates

► Installation of the hydraulic unit

▼ Installation precautions

- Choose the location of the appliance after discussion with the client.
- The installation space should comply with current regulations.
- To facilitate maintenance and allow access to the various parts, we recommend that you provide sufficient space all the way around the hydraulic unit.



- In accordance with EN 378-1 -2017 standard (Refrigerating systems and heat pumps - Safety and environmental requirements), the system's hydraulic unit and all refrigeration connections passing through inhabited areas must comply with the minimum room volume requirements shown hereafter.

The minimum volume of a room (in m³) is calculated using the formula: "fluid fill load" (in kg) / 0.39.

Alternatively, you must ensure that

- The location has natural ventilation through another room where the combined volume of the two rooms is greater than "liquid fill load" (in kg) / 0.39 kg/m³. The opening between the two rooms must have a door clearance of at least 1 cm.
- Or that the location is mechanically ventilated.

Be careful not to bring flammable gas near the heat pump during installation, in particular when brazing is required. The appliances are not fireproof and should not therefore be installed in an explosive environment.

- To avoid condensation inside the condenser, remove the refrigeration circuit caps **only when making the refrigeration connections**.

- If the refrigeration connection is only performed at the end of the installation, make sure that the refrigeration circuit caps* remain in place and tight throughout the installation.

* (Hydraulic unit side and outdoor unit side).

- After each maintenance operation on the refrigeration circuit and before the final connection, take care to put the caps back in position to avoid any pollution of the refrigeration circuit (sealing with adhesive is prohibited).

▼ Positioning the hydraulic unit

- Fix the bracket **S** securely (4 screws and plugs) to a strong, flat wall (not a light partition) ensuring that it is correctly levelled.

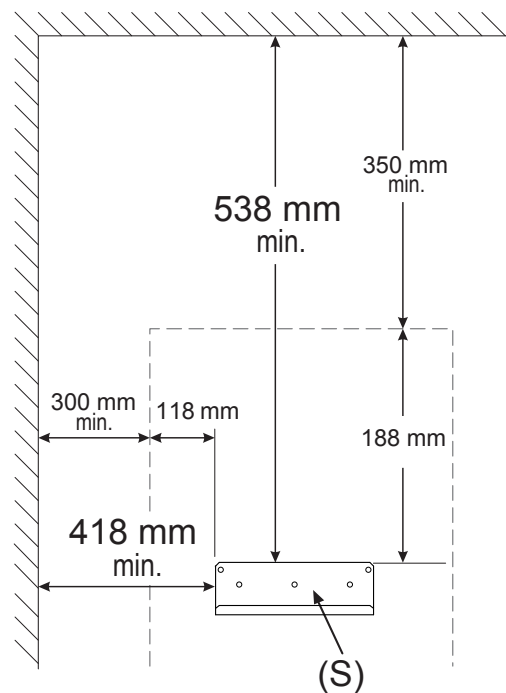

fig. 15 - Mounting bracket

- Hook the appliance onto its bracket **S**.



Weight of the appliance (full of water) = 58Kg

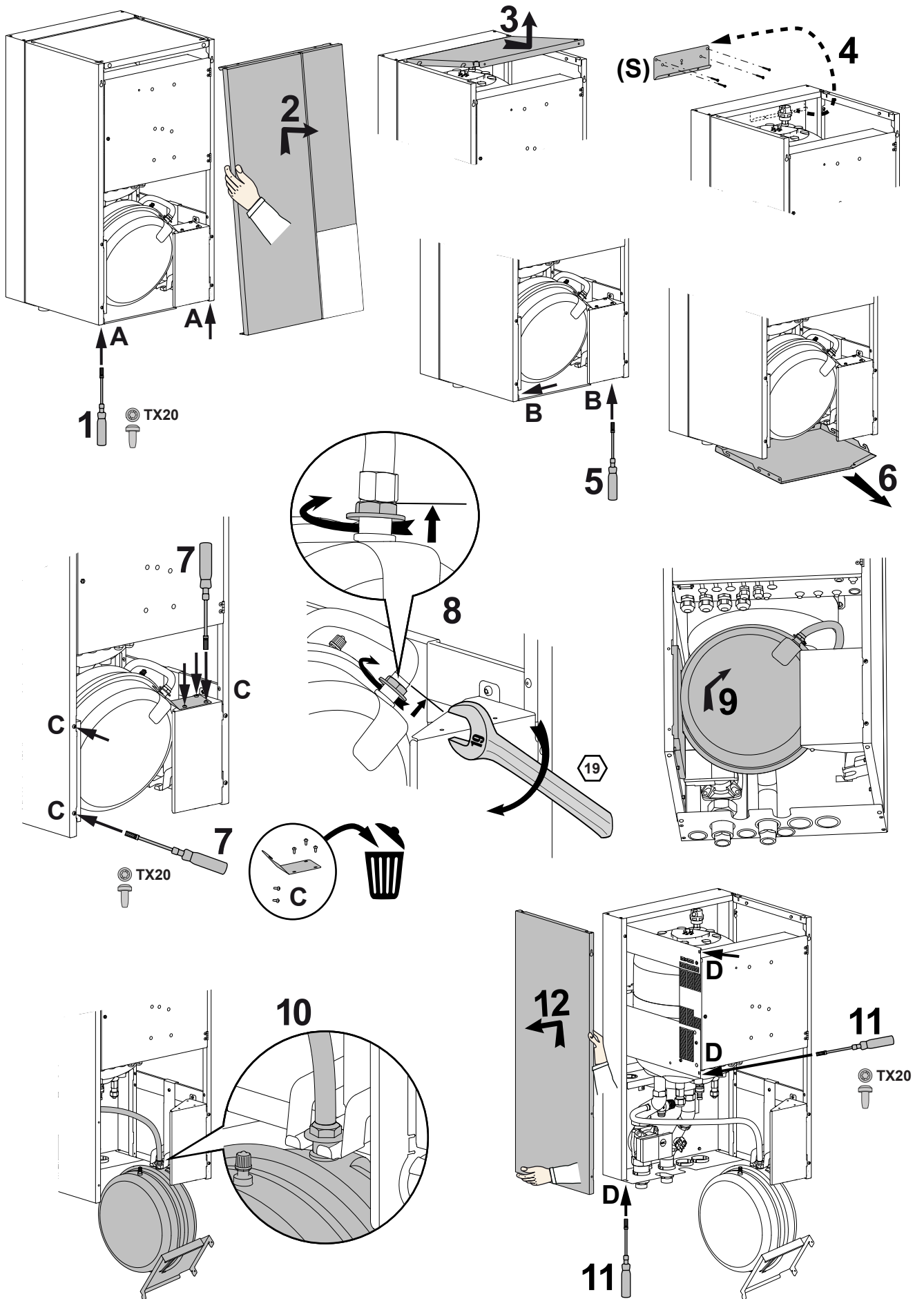

fig. 16 - Removing the casing

Refrigeration connections

This appliance uses refrigerant R410A.

Comply with the legislation on handling of refrigerants.

Rules and precautions

i Connections must be made on the same day the installation is filled with gas (see para. "Filling the installation with gas", page 26).

• Minimum tools required

- Set of pressure gauges (*Manifold*) with hoses exclusively designed for HFCs (Hydrofluorocarbons).
- Vacuum gauge with isolation valves.
- Vacuum pump specifically for HFCs (using a standard vacuum pump is allowed if, and only if, it is fitted with a non-return valve on the suction side).
- Flaring tool, Pipe-cutter, Deburring tool, Spanners.
- Certified refrigerant leak detector (sensitivity 5g/year).

Using tools that have been in contact with HCFCs (R22 for example) or CFCs is prohibited.

The manufacturer declines any liability with regard to the warranty if the above instructions are not observed.

• Flared connections

Lubricating with mineral oil (for R12, R22) is prohibited.

- Lubricate only with polyolester oil (POE). If POE is not available, fit without lubrication

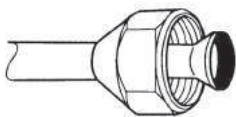

Coat the flared surface with **POE refrigeration oil**.
Do not use mineral oil.

• Brazing the refrigeration circuit (if necessary)

- Silver brazing (40% minimum recommended).
- Brazing only with dry nitrogen internal flux.

• Other remarks

- After each maintenance operation on the refrigeration circuit and before final connection, take care to put the caps back in position to avoid any pollution of the refrigeration circuit.
- To eliminate any filings getting into the pipes, use dry nitrogen to avoid introducing any humidity that may adversely affect the appliance's operation. In general, take every precaution to avoid humidity penetrating into the appliance.
- Proceed with thermal insulation of the gas and liquid pipes to avoid any condensation. Use pipe insulators resistant to temperatures over 90°C. In addition, if the humidity level in areas where the refrigerant pipes are installed is expected to exceed 70%, protect the pipes with pipe insulators. Use an insulating material thicker than 15mm if the humidity level reaches 70 ~ 80%, and an insulating material thicker than 20mm if the humidity exceeds 80%. If the recommended thicknesses are not observed under the conditions

described above, condensation will form on the surface of the insulation material. Lastly, use insulating sleeves whose thermal conductivity will be less than or equal to 0.045 W/mK if the temperature is equal to 20°C. The insulation must be impermeable in order to withstand the passage of vapour during the defrosting cycles (glass wool is prohibited).

Shaping the refrigeration pipes

▼ Bending

The refrigeration pipes must be shaped only on a bending machine or with a bending spring in order to avoid any risk of crushing or breaking them.

Remove the insulation material from the section of pipe to be bent.

i Do not bend copper to an angle greater than 90°. Never bend pipes more than 3 times in the same place otherwise traces of fracturing may appear (hardening of the metal).

▼ Creating the flarings

- Cut the pipe to an appropriate length with a pipe-cutter without damaging it.
- Carefully deburr it, holding the pipe pointing downward to avoid introducing filings into the pipe.
- Remove the flared connection nut situated on the valve to be connected and slide the pipe into the nut.
- Proceed to flare it, letting the pipe protrude out of the flaring tool's tube.
- After flaring, check the state of the working radius (**L**). This must not present any scratches or signs of fracturing. Also check the dimension (**B**).

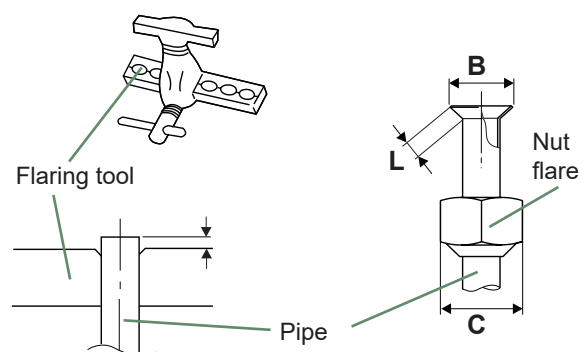

Pipe ϕ	Dimensions in mm		
	L	B $\phi_{0.4}$	C
9.52 (3/8")	2.5 to 2.7	13.2	22
15.88 (5/8")	2.9 to 3.1	19.7	29

fig. 17 - Flaring of the flared connections

■ Outdoor unit

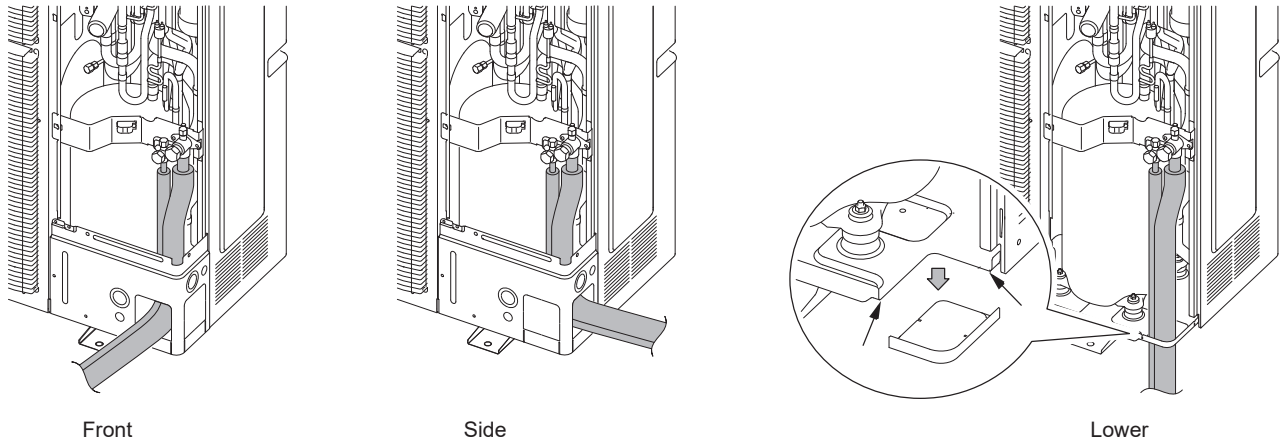

■ Hydraulic unit

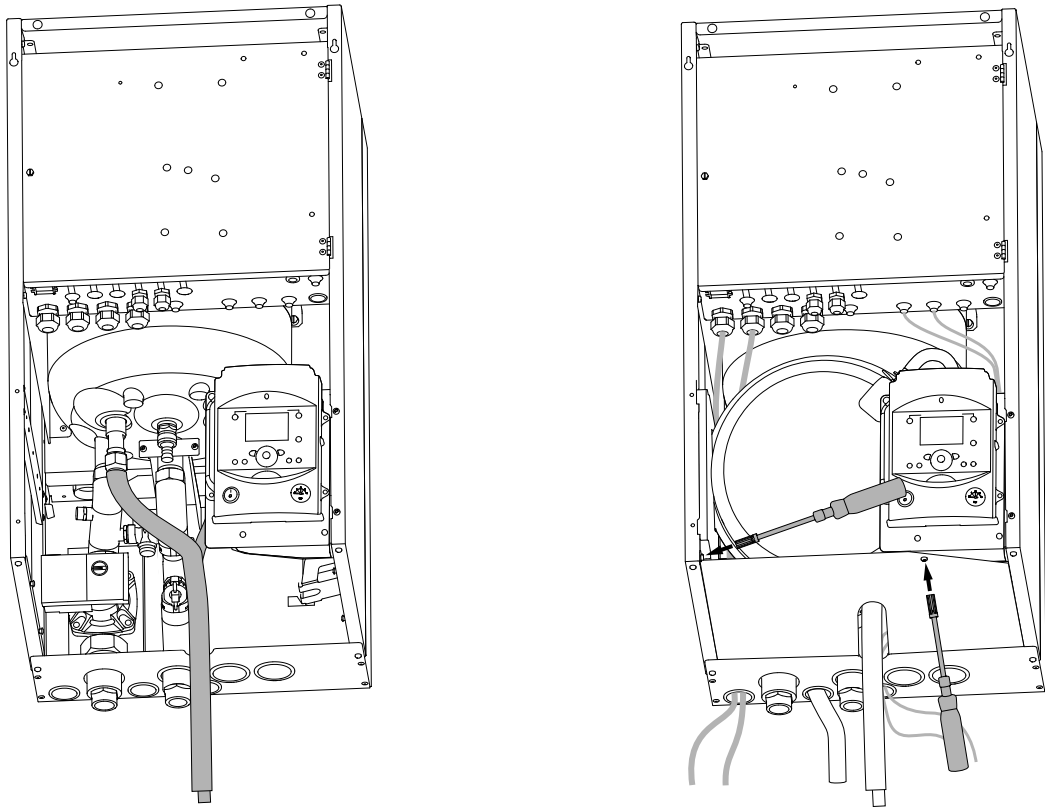

fig. 18 - Feeding through flared connections

HP model	Waterstage SHP	
	gas	liquid
Outside unit connections	5/8"	3/8"
Refrigeration connections	Diameter	(D1) 5/8" (D2) 3/8"
	Minimum length (L)	5
	Maximum length ¹ (L)	15
	Maximum length ² (L)	30
Maximum Height Difference ^{2/3} (D)	25 / 15	
Hydraulic unit connections	5/8"	3/8"

1 Without additional filling of R410A.

2 Taking into account a possible additional fill of refrigerant R410A (see "Additional filling", page 28).

3 Outdoor unit over hydraulic unit and heating only / Other cases.

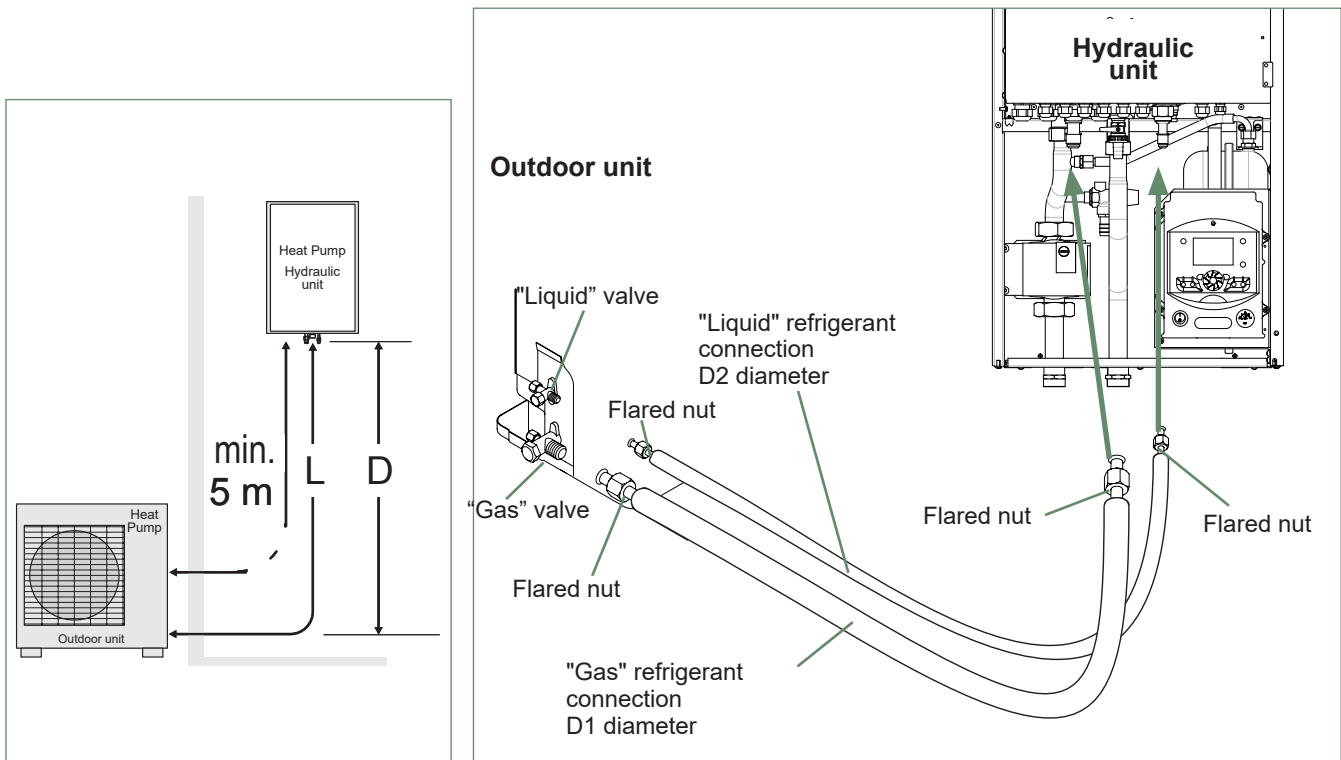

fig. 19 - Refrigeration connections (authorised diameters and lengths)

► Checks and connection



The refrigeration circuit is very sensitive to dust and humidity: check that the area around the connection is clean and dry before removing the plugs protecting the refrigeration connectors.

Indicated blowing value: 6 bar for minimum 30 seconds for connection of 20 m.

Checking the gas connection (large diameter).

① Connect the gas connection to the outdoor unit. Blow dry nitrogen into the gas connection and inspect its end:

- If water or impurities emerge, use a brand new refrigeration connection.

② Otherwise, proceed with flaring and connect the refrigeration connection to the outdoor unit immediately.

Checking the liquid connection (small diameter).

③ Connect the liquid connection to the hydraulic unit. Blow nitrogen into the **gas-condenser-liquid connection** system and inspect its end (outdoor unit side).

- If water or impurities emerge, use a brand new refrigeration connection.

- Otherwise, proceed with flaring and connect the refrigeration connection to the outdoor unit immediately.



Take particular care to position the tube opposite its connector so as not to risk damaging the threads. A properly aligned connector can be attached easily by hand without much force being required.

- Remove the plugs from the pipes and the refrigeration connections.

- **Warning!** Avoid positioning the gas pipe in front of the pump.

- Comply with the indicated tightening torques.

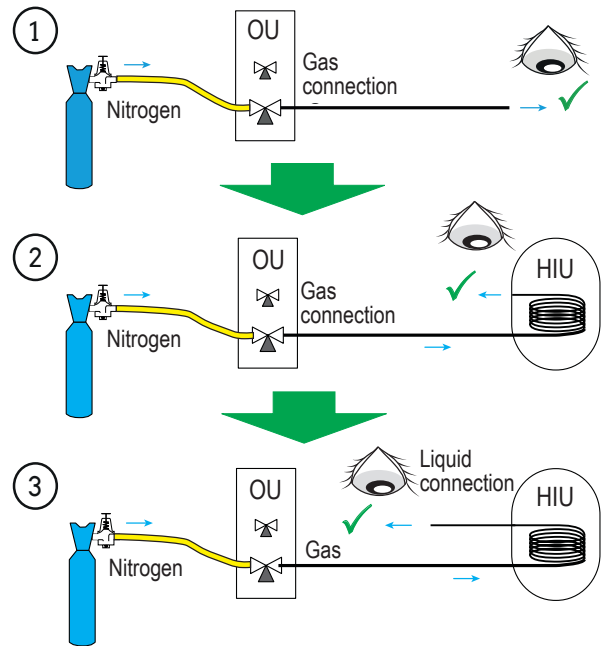
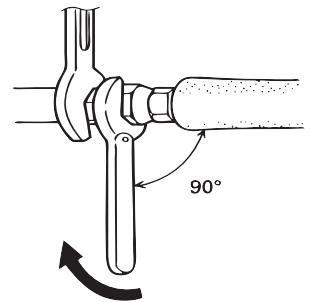

fig. 21 - Checking refrigeration connections

Holding spanner

Torque wrench



Designation	Tightening torque
Flared nut 9.52 mm (3/8")	32 to 42 Nm
Flared nut 15.88 mm (5/8")	63 to 77 Nm
Plug (A) 3/8"	20 to 25 Nm
Plug (A) 5/8"	30 to 35 Nm
Plug (B) 3/8", 5/8"	10 to 12 Nm

Plug (A) and (B) : see fig. 22, page 27.

fig. 20 - Tightening torques

► Filling the installation with gas



This operation is reserved for installers familiar with the legislation for handling refrigerants. Creating a vacuum with a calibrated vacuum pump is essential (see APPENDIX 1). Never use equipment used previously with any refrigerant other than a HFC. Only remove the refrigeration circuit caps when performing the refrigeration connections.

If the outdoor temperature is below +10°C:

- You must use the triple evacuation method (see APPENDIX 2).
- We recommend installing a dehydrator filter (and this is highly recommended if the outdoor temperature is below +5°C).

APPENDIX 1

Method for calibrating and checking a vacuum pump

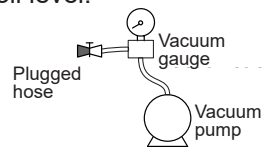
- Check the vacuum pump's oil level.
 - Connect the vacuum pump to the vacuum gauge as shown in the diagram.
- 
- Pump down for 3 minutes.
 - After 3 minutes, the pump reaches its threshold vacuum limit and the vacuum gauge's needle stops moving.
 - Compare the obtained pressure value against the table of values. Depending on the temperature, this pressure should be lower than that shown in the table.
- => If this is not the case, replace the gasket, hose or pump.

T °C	5°C < T < 10°C	10°C < T < 15°C	15°C < T
Pmax			
- bar	0.009	0.015	0.020
- mbar	9	15	20

APPENDIX 2

Triple Evacuation Method

- Connect the *Manifold* high-pressure hose to the filling hole (gas connection). A valve must be fitted to the vacuum pump's hose so you can shut it off.

a) Create a vacuum until the desired value is reached and maintain this value for 30 mins (see table in APPENDIX 1),

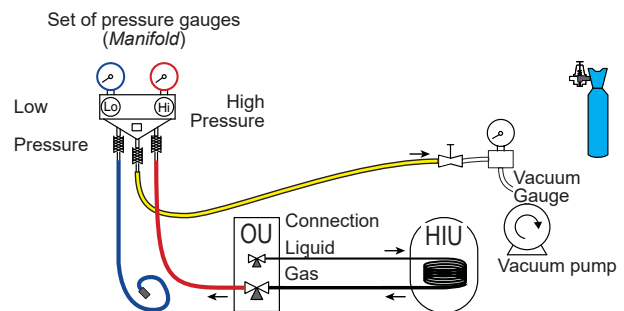

b) Switch off the vacuum pump, close the valve at the end of the service hose (yellow), connect this hose to the expansion valve on the nitrogen bottle, fill to 2 bar, close the hose's valve again,

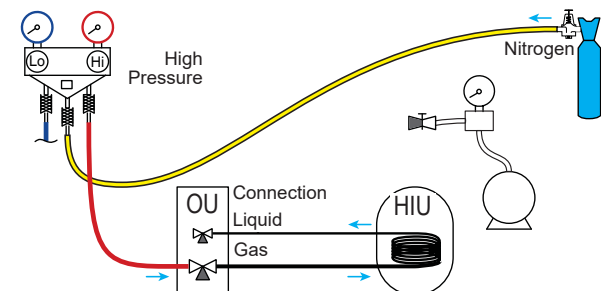

c) Connect this hose to the vacuum pump again, switch it on and slowly open the hose's valve.

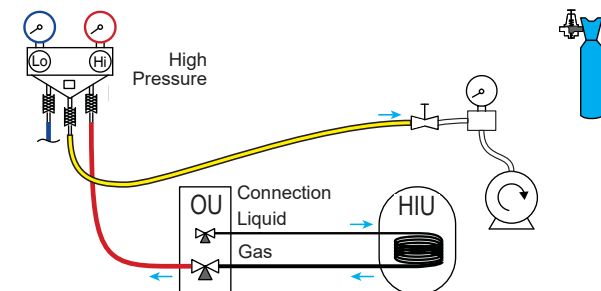

d) Repeat this operation at least three times.

Remember: performing these operations using refrigerant is strictly prohibited.

▼ Seal test

- Remove the protective plug (B) from the filling hole (Schrader) in the gas valve (large diameter).
- Connect the high pressure hose from the *Manifold* to the filling hole (fig. 22).
- Connect the nitrogen bottle to the *Manifold* (only use dehydrated nitrogen type U).
- Fill the refrigeration circuit with nitrogen to maximum 10 bar (**gas-condenser-liquid connection system**).
- Maintain this pressure in the circuit for 30 minutes.

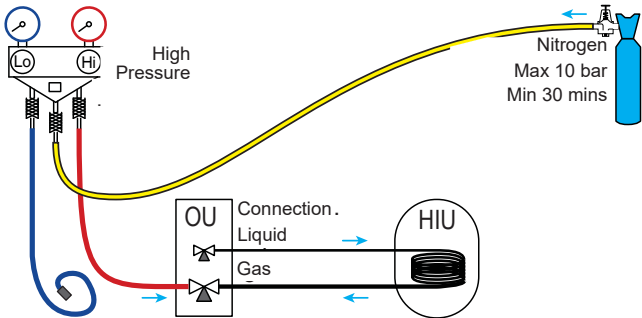

- If a pressure drop occurs, bring it back down to 1 bar and look for leaks with a leak detector, repair and repeat the test.

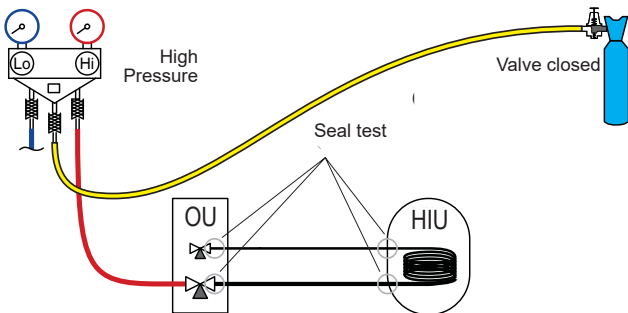

- Once the pressure is steady and there are no leaks, empty the nitrogen by leaving the pressure above atmospheric pressure (between 0.2 and 0.4 bar).

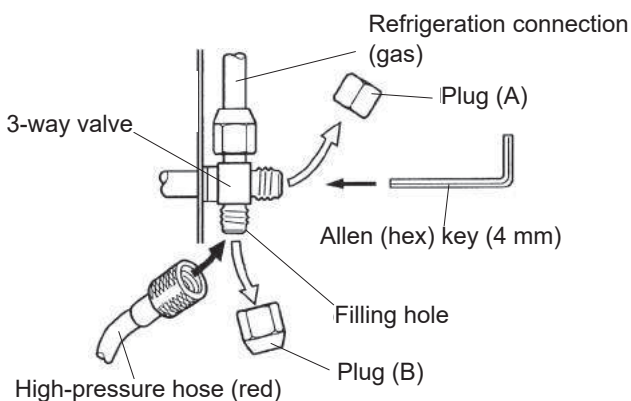

fig. 22 - Connecting the hose to the gas valve

▼ Creating a vacuum



The triple evacuation method (APPENDIX 2) is strongly recommended for any installation and especially when the outdoor temperature is below 10°C.

- If necessary, calibrate the *Manifold* pressure gauge(s) to 0 bar. Adjust the vacuum gauge to current atmospheric pressure (≈ 1013 mbar).
- Connect the vacuum pump to the *Manifold*. Connect a vacuum gauge if the vacuum pump is not equipped with one.

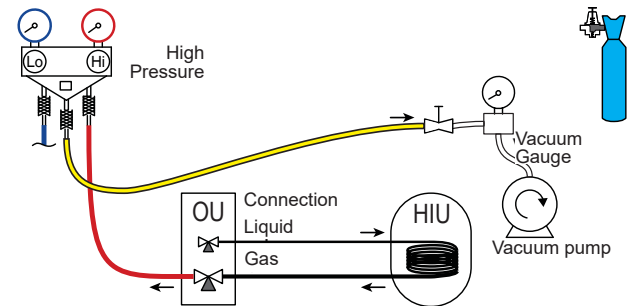

- Create a vacuum until the residual pressure* in the circuit falls below the value given in the following table (* measured with the vacuum gauge).

T °C	5°C < T < 10°C	10°C < T < 15°C	15°C < T
Pmax - bar	0.009	0.015	0.020
- mbar	9	15	20

- Let the pump continue to operate for another 30 minutes minimum after reaching the required vacuum.
- Close the *Manifold* valve, then stop the vacuum pump **without disconnecting any of the hoses in place.**

▼ Filling with gas

i If additional filling is required, do it before filling the hydraulic unit with gas. Refer to paragraph "Additional filling", page 28.

- Remove the access plugs (A) from the valve controls.
- First of all fully open the liquid valve (small) and then the gas valve (large) using an Allen (hex) key (anti-clockwise direction) without using excessive force against the stop.
- Quickly disconnect the hose from the *Manifold*.
- Refit the 2 original caps (be sure they are clean) and tighten them to the recommended tightening torque indicated in the table fig. 20, page 25. A seal is achieved in the caps only with metal to metal.

The outdoor unit does not contain any additional refrigerant allowing the installation to be bled.

Bleeding by flushing is strictly forbidden.

▼ Final sealing test

The sealing test must be carried out using a certified gas detector (sensitivity of 5g/year).

Once the refrigeration circuit has been gassed as described above, check that all the refrigeration connectors are gas-tight (4 connectors). If the flarings have been made correctly, there should be no leaks. If necessary, check the seal of the refrigeration valve caps.

If the event of a leak:

- Return the gas to the outdoor unit (pump down). The pressure should not drop below atmospheric pressure (0 relative bar read on the *Manifold*) so as not to contaminate the recovered gas with air or moisture.
- Redo the connection,
- Restart the commissioning procedure.

▼ Additional filling

	50 g of R410A for every additional 1 metre	
Length of the connections	15 m	30 m max.
Additional load	None	750 g

The amount needed to fill the outdoor units corresponds to the maximum distances between the outdoor unit and the hydraulic unit as defined here page 24. If the distances are greater, an additional amount of R410A is required. For each type of appliance, this additional amount depends on the distance between the outdoor unit and the hydraulic unit. Any additional filling with R410A must be carried out by an approved specialist.

• Example of additional fill:

An outdoor unit which is 17 m away from the hydraulic unit will require an additional fill of:

$$\text{Additional fill} = (17 - 15) \times 50 = 100 \text{ g}$$

Filling must be carried out after creating a vacuum and before gassing the hydraulic unit, as follows:

- Disconnect the vacuum pump (yellow hose) and connect a bottle of R410A in its place **in the fluid extraction position**.
- Open the bottle's valve.
- Bleed the yellow hose by loosening it slightly on the *Manifold* side.
- Place the bottle on scales with a minimum accuracy of 10g. Note the weight.
- Carefully open the blue valve slightly and check the value shown on the scales.
- As soon as the value displayed has dropped by the value for the calculated additional fill amount, close the bottle and disconnect it.
- Quickly disconnect the hose connected to the appliance.
- Proceed to fill the hydraulic unit with gas.

Only use R410A !

Only use tools suitable for R410A (set of pressure gauges).

Always fill in the liquid phase.

Never exceed the maximum length or difference in level.

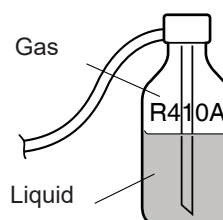

fig. 23 - Gas bottle R410A

▼ Recovering the refrigerant in the outdoor unit



Before performing any maintenance, make sure that all power supplies have been cut off.

Stored energy: after cutting off the power supplies, wait for 1 minute before accessing the internal parts of the equipment.



Perform the following procedures to collect the refrigerant.

- **1-** Switch the start/stop switch to the 0 position (mark **3**, fig. 9, page 13). Disconnect the outdoor unit's power supply.
- **2-** Remove the front panel. Open the power control box. Then turn **ON** the **DIP SW1** on the interface board,
- **3-** Reconnect the power supply. Switch the start/stop switch to position 1. (The green and red LEDs start flashing; 1s on / 1s off). The outdoor unit begins cooling operation about 3 minutes after being switched on.
- **4-** The circulation pump starts.
- **5-** Close the liquid valve on the outdoor unit **maximum** 30 secs after the outdoor unit starts.
- **6-** Close the gas valve on the outdoor unit when the pressure is below 0.02 relative bar read on the *Manifold*, or 1-2 minutes after the liquid valve has been closed, while the outdoor unit continues to operate.
- **7-** Disconnect the power supply.
- **8-** Recovery of the refrigerant is complete.

Notes:

- The pump down operation cannot be activated even if **DIP SW1** is set to **ON** while the heat pump is in operation.
- Do not forget to switch **DIP SW1** back to **OFF** after the pump down operation has been completed.
- Select the heating mode.
- If the pump down operation fails, try the operation again by turning the machine off and opening the "liquid" and "gas" valves. Then after 2-3 minutes, restart the pump down operation.

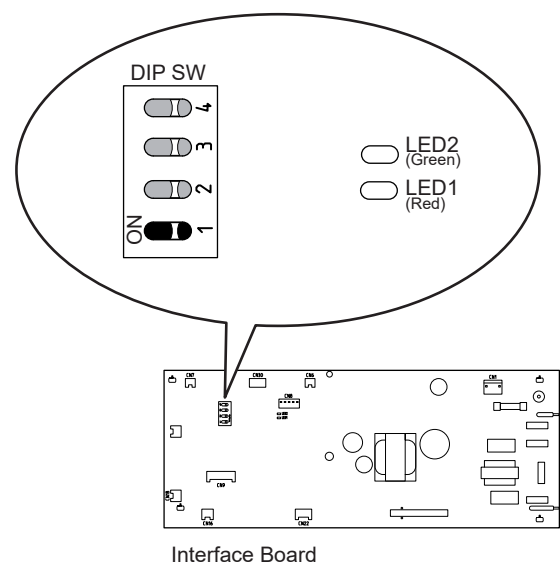

fig. 24 - Location of DIP switches and LEDs on the hydraulic unit interface board

Hydraulic connections

► Connecting the hydraulic unit to the heating circuit

▼ Flushing the installation

Before connecting the hydraulic unit to the installation, **rinse out the heating system correctly** to eliminate any particles that may affect the appliance's correct operation.

Do not use solvents or aromatic hydrocarbons (petrol, paraffin, etc.).

In the case of an old installation, provide a sufficiently large decanting pot with a drain on the return from the boiler and at the lowest point in the system in order to collect and remove any impurities.

Add an alkaline product and a dispersant to the water.

Flush the installation several times before proceeding to the final filling.

▼ Connections

The heating circulation pump is built into the hydraulic unit.

Connect the central heating pipes to the hydraulic unit correctly according to the direction of circulation.

The pipe between the hydraulic unit and the heat collector must be at least one inch in diameter (26x34 mm).

Calculate the diameter of the pipes based on flow rates and lengths of the hydraulic systems.

Tightening torque: 15 to 35 Nm.

Use union connectors to make it easier to remove the hydraulic unit.

Try to use connection hoses to avoid transmitting noise and vibrations to the building.

Connect the drains from the drain valve and the safety valve to the main sewer system.

Verify that the expansion system is correctly connected. Check the expansion vessel pressure (pre-inflated to 1 bar) and the safety valve is calibrated.

The flow rate of the installation must be at least equal to the minimum value mentioned in the specifications table "General characteristics", page 7. The installation of a regulator (other than those included in our configurations) which reduces or stops the flow through the hydraulic unit is prohibited.

▼ Volume of the heating system

You must maintain the minimum installation water volume. Install a buffer tank on the return from the heating circuit in case the volume is lower than this value. Where the system is fitted with one or more thermostatic valves, you must ensure that this minimum water volume is able to circulate.

Appliance	Min. volume in litres PER CIRCUIT (excl. HP)		
	Mandatory Fan-coil	Recommendation Radiators	Recommendation Heating-cooling floor
Waterstage SHP 16	110	98	55
Waterstage SHP TRI 15	102	90	50
Waterstage SHP TRI 17	119	106	60

► Filling and bleeding the installation

Check the pipe fixings, tightness of the connectors and the stability of the hydraulic unit.

Check the direction in which the water is circulating and that all the valves are open.

Proceed to fill the installation.

Do not operate the circulation pump during filling. Open all the drain valves in the installation and the bleeder valve on the hydraulic unit to expel the air contained in the pipes.

Close the drain valves and add water until the pressure in the hydraulic circuit reaches 1 bar.

Check that the hydraulic circuit has been bled correctly.

Check there are no leaks.

After the "⚙️ Commissioning", page 44, and once the machine has started, bleed the hydraulic unit again.

i Precise filling pressure is determined by the water pressure in the installation.

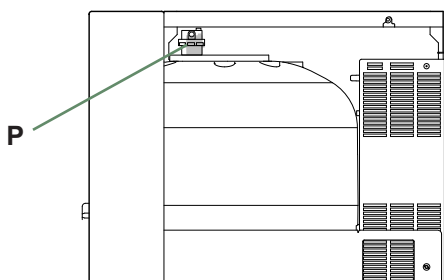
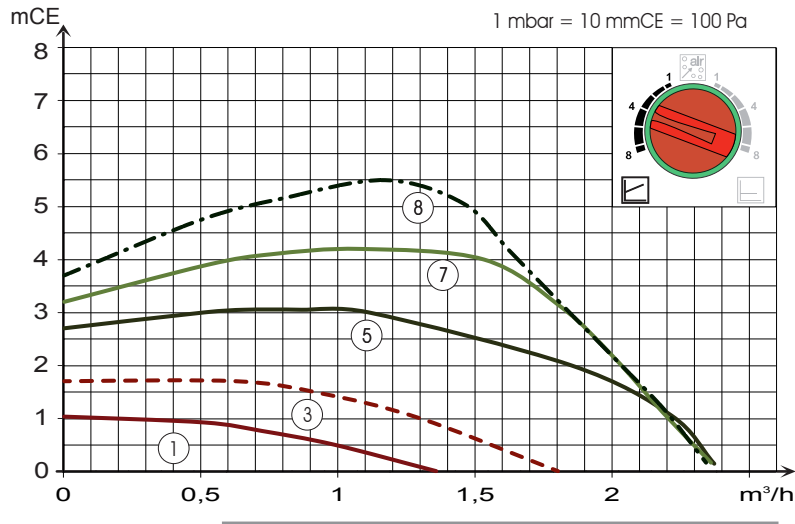

fig. 25 - Hydraulic unit automatic bleeder valve

► Heating circulation pump speed settings



Variable pressure

The circulation pump varies the water pressure depending on the flow rate.

Recommended for an installation fitted with **radiators** (particularly any system with thermostatic valves or zone solenoids).

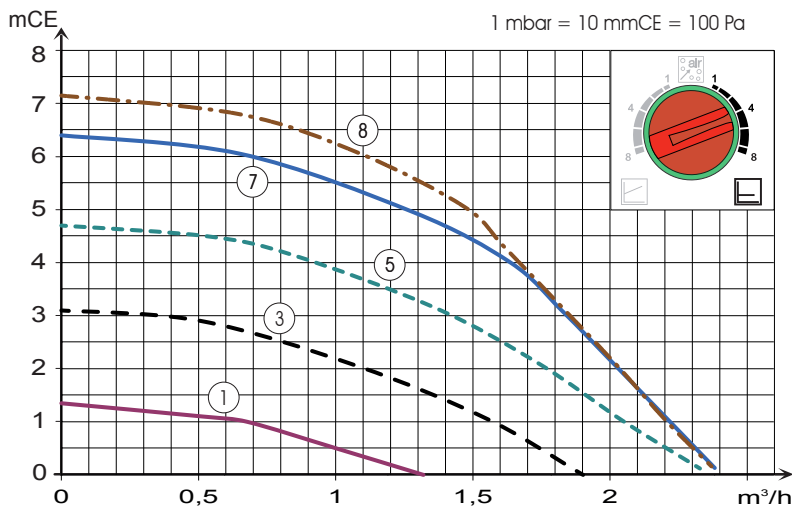
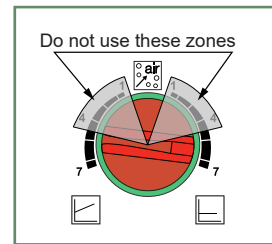

Constant pressure

The circulation pump maintains a constant water pressure whatever the flow rate.

Recommended for an installation with constant pressure drops such as an **underfloor heating system**.

fig. 26 - Available hydraulic pressures and flow rates

	OFF	LED Off: The circulation pump is not working, no power supply.
		Green LED On: The circulation pump is operating normally.
	10 min.	Green LED flashing: Venting mode in operation (10 minutes).
	Auto Test	Red/green LED flashing: Operating error with automatic restart.
		Red LED flashing: Operating error.

fig. 27 - Operating signals of the HP circulation pump

 Variable pressure

 Gas venting

 Constant pressure

Circulation pump fouled or stuck:

If the motor becomes stuck, a start-up cycle is launched.
If the motor remains stuck, it will be permanently stopped.

Cut off the power supply to the circulation pump for 30 secs in order to free it and allow a new start-up cycle to begin.

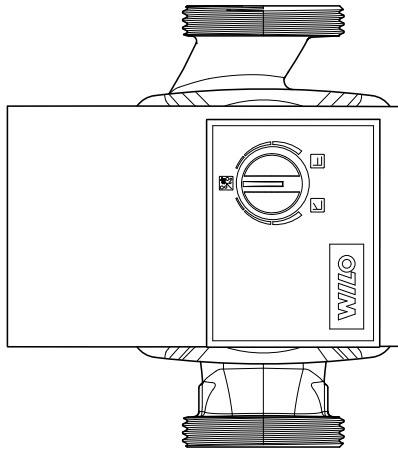

fig. 28 - Circulation pump control button

Electrical connections



Before any maintenance operation, ensure that the general power supply is switched off.
Electrical installation must be performed in accordance with current regulations.



The electrical diagram for the hydraulic unit is shown on [fig. 43, page 72](#).

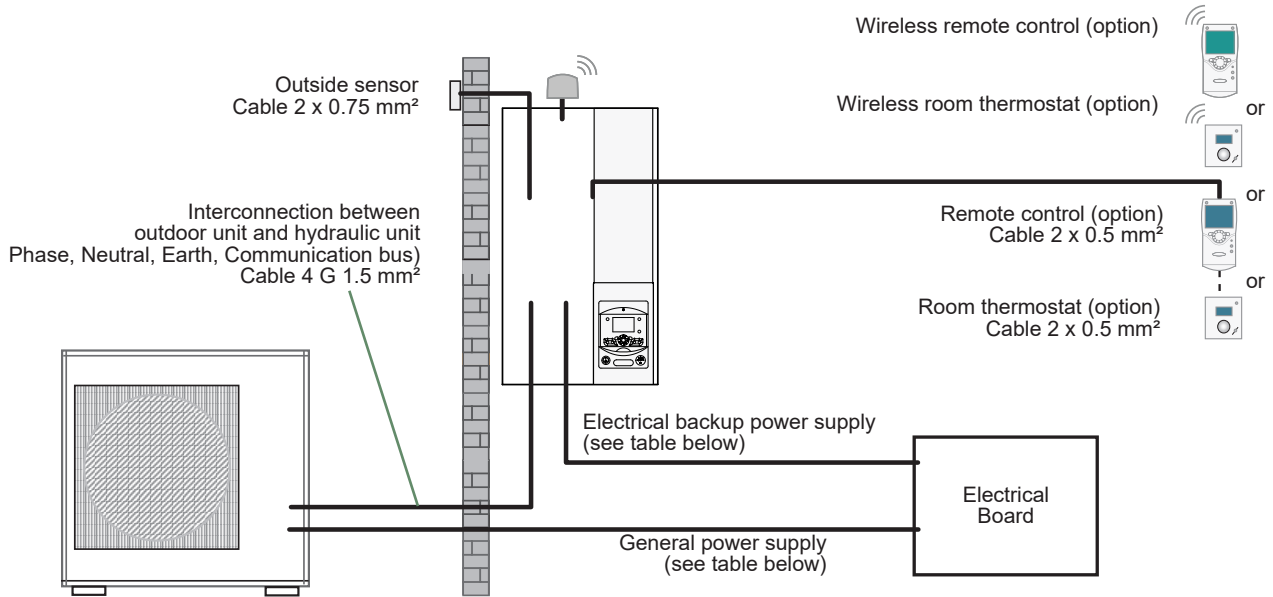

fig. 29 - Overall layout of electrical connections for a simple installation (1 heating circuit)

► Cable dimensions and protection rating

These cable dimensions are provided for information purposes only and do not exempt the installer from checking that these dimensions match requirements and comply with current standards.

• Outdoor Unit Power Supply

<i>Single phase heat pump</i>		<i>Electricity supply 230 V - 50 Hz</i>	
<i>Model</i>	<i>Max. power consumption</i>	<i>Connection cable ⁽¹⁾ (phase, neutral, earth)</i>	<i>Circuit breaker C curve</i>
Waterstage SHP 16	6300 W	3 G 6 mm ²	32 A
<i>3 phase heat pump</i>		<i>Electricity supply 400 V - 50 Hz</i>	
<i>Model</i>	<i>Maximum power</i>	<i>Connection cable ⁽¹⁾ (3 phases, neutral, earth)</i>	<i>Circuit breaker C curve</i>
Waterstage SHP TRI 15	6770 W	5 G 2.5 mm ²	20 A
Waterstage SHP TRI 17	7400 W		

• Interconnection between outdoor unit and hydraulic unit

The hydraulic unit is powered by the outdoor unit by means of a 4 G 1.5 mm² cable (phase, neutral, earth, communication bus).

• Electrical backup power supply

The hydraulic unit contains a electrical backup circuit (and a second optional) installed in the storage tank.

<i>Heat pump</i>	<i>Electrical backups</i>		<i>Electrical backup power supply</i>	
<i>Model</i>	<i>Power</i>	<i>Nominal current</i>	<i>Connection cable ⁽¹⁾ (phase, neutral, earth)</i>	<i>Circuit breaker C curve</i>
Waterstage SHP 16	2 x 3 kW	26.1 A	3 G 6 mm ²	32 A
Waterstage SHP TRI 15 Waterstage SHP TRI 17	9 kW	3 x 13 A	4 G 2.5 mm ²	20 A

⁽¹⁾ Cable type 60245 IEC 57 or 60245 IEC 88.

• DHW power supply (option)

The DHW section is powered directly via a 3 G 1.5 mm² cable (phase, neutral, earth).
Protection by rated circuit breaker (16 A - C curve).

► Electrical connections on the outdoor unit side

Access to connection terminals:

- Remove the front plate. Remove the screws and front panel.
- Make the connections according to the diagram(s) fig. 34, page 40.

 Use cable clamps to prevent any power cables from being disconnected accidentally.

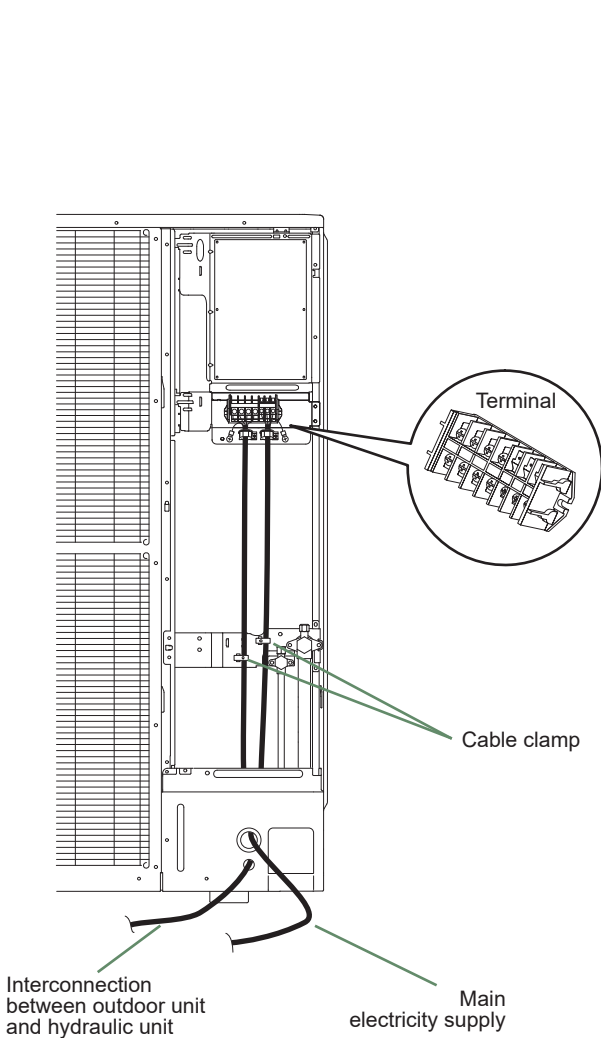
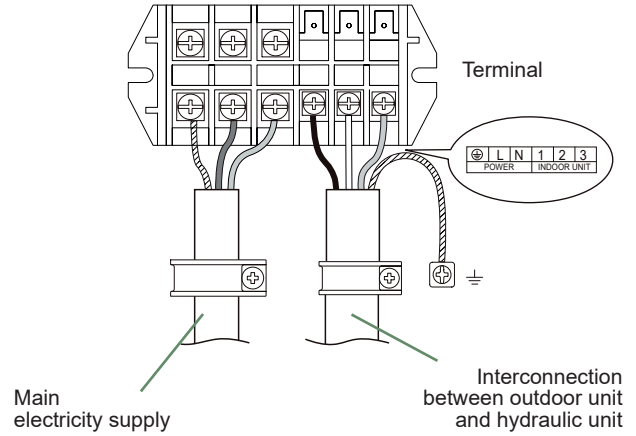

fig. 30 - Access to outdoor unit's terminal block

■ Waterstage SHP 16



■ Waterstage SHP TRI 15 Waterstage SHP TRI 17

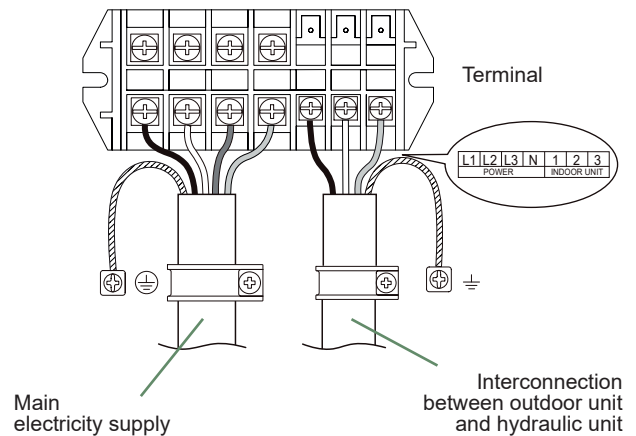
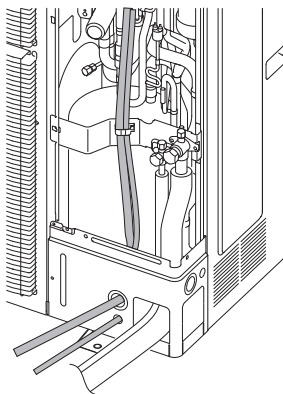
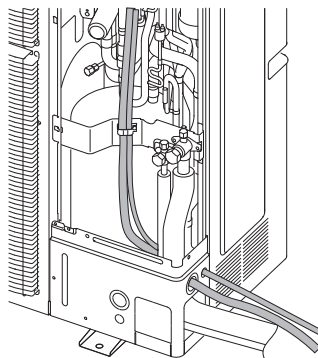

fig. 31 - Connections of the outdoor unit's terminal block



front



side

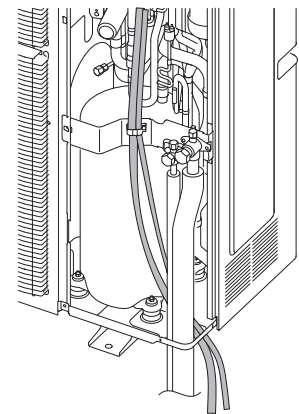

lower

fig. 32 - Feeding cables and refrigeration connections from the outdoor unit



A series of horizontal dotted lines spanning the width of the page, providing a guide for handwriting practice.

► Electrical connections on the hydraulic unit side

Access to connection terminals:

- Remove the front panel (2 screws).
 - Open the power control box.
 - Make the connections according to the diagram (fig. 34).
- Do not place the sensor and power supply lines parallel to each other to avoid interference due to voltage spikes in the power supply.

Make sure that all electrical cables are housed in the areas provided for this purpose.

▼ Interconnection between outdoor unit and hydraulic unit

Match up the terminal block markers on the hydraulic unit to those of the outdoor unit exactly when connecting the interconnection cables.

An incorrect connection could result in the destruction of one or other of the units.

▼ Electrical backups

If the heat pump is not installed with a boiler connection:

- Connect the power supply for the backup to the electrical panel.

▼ Boiler connection (optional)

i If the boiler connection option is used, the electric backup option must not be connected.

- Please refer to the instructions supplied with the boiler connection kit.
- Please refer to the instructions supplied with the boiler.

▼ Second heating circuit (optional)

- Refer to the instructions supplied with the double hydraulic circuit kit.

▼ DHW tank with electrical backup heating (optional)

If the installation is fitted with a DHW tank :

- Please refer to the instructions supplied with the DHW kit.
- Please refer to the instructions supplied with the DHW tank.



You must equipped the DHW electrical backup heating with a manual reset thermostat.

▼ Contract with Energy Supplier

The heat pump can be set to operate within particular types of energy contract, e.g. off-peak, day/night. In particular, domestic hot water (DHW) at the comfort temperature will be produced at off-peak times when electricity is at its cheapest.

- Connect the "Power Provider" contact to input EX2.
- Set the DHW configuration to "Off-Peak".
- 230V on input EX2 = "Peak Hours" information activated.

▼ Power limitation or EDR (Energy Demand Reduction)

Power limitation is designed to reduce electricity consumption when it is too high for the contract signed with the energy supplier.

- Connect the power limiter device to input EX1. Heat pump and DHW backups will be shut off in the event of over-consumption by the dwelling.
- 230 V on input EX1 = power limitation in progress.

▼ Faults external to the heat pump

Any component which reports back information (Underfloor heating safety switch, thermostat, pressure switch, etc.) may signal an external problem and stop the heat pump.

- Connect the external component to input EX3.
- 230 V on input EX3 = heat pump stopped (system displays Error 369).

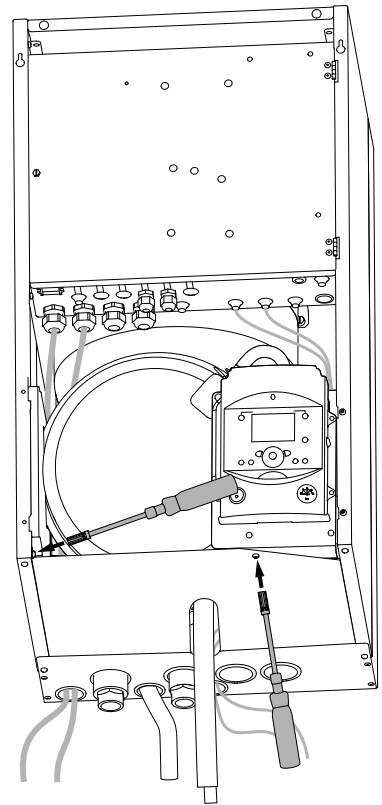
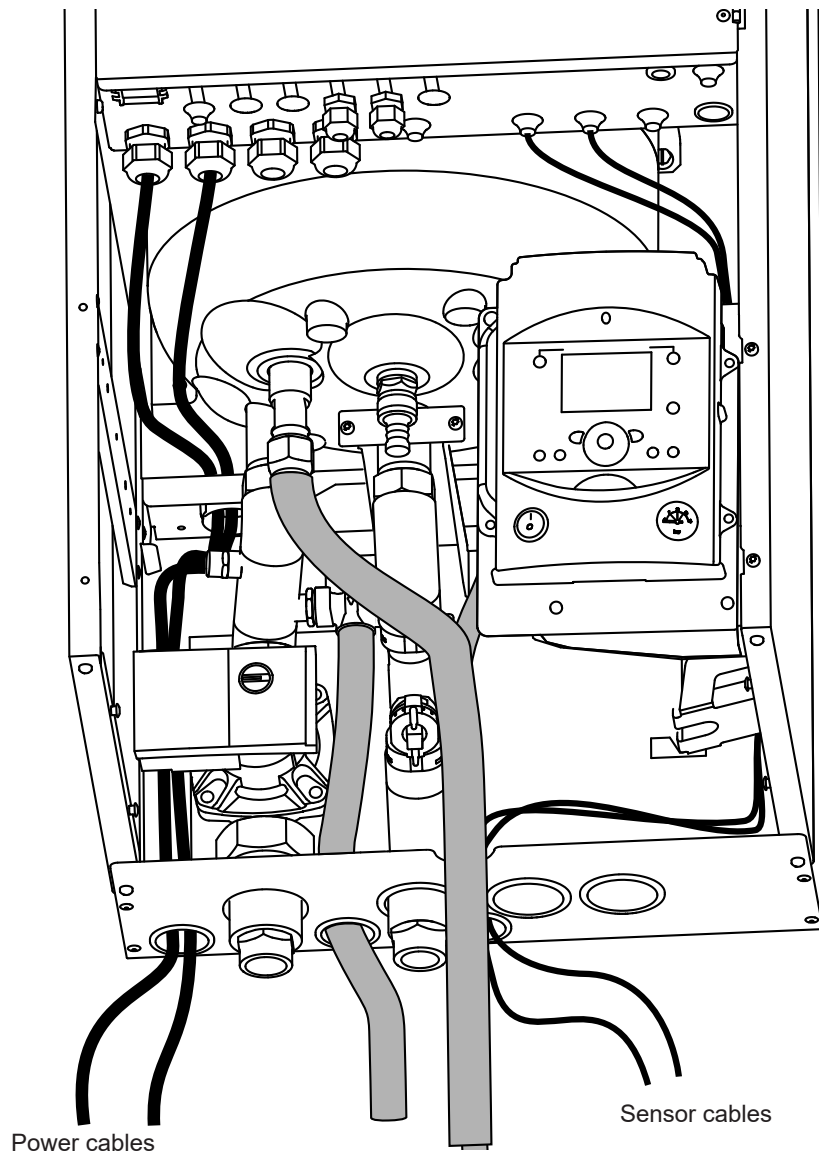
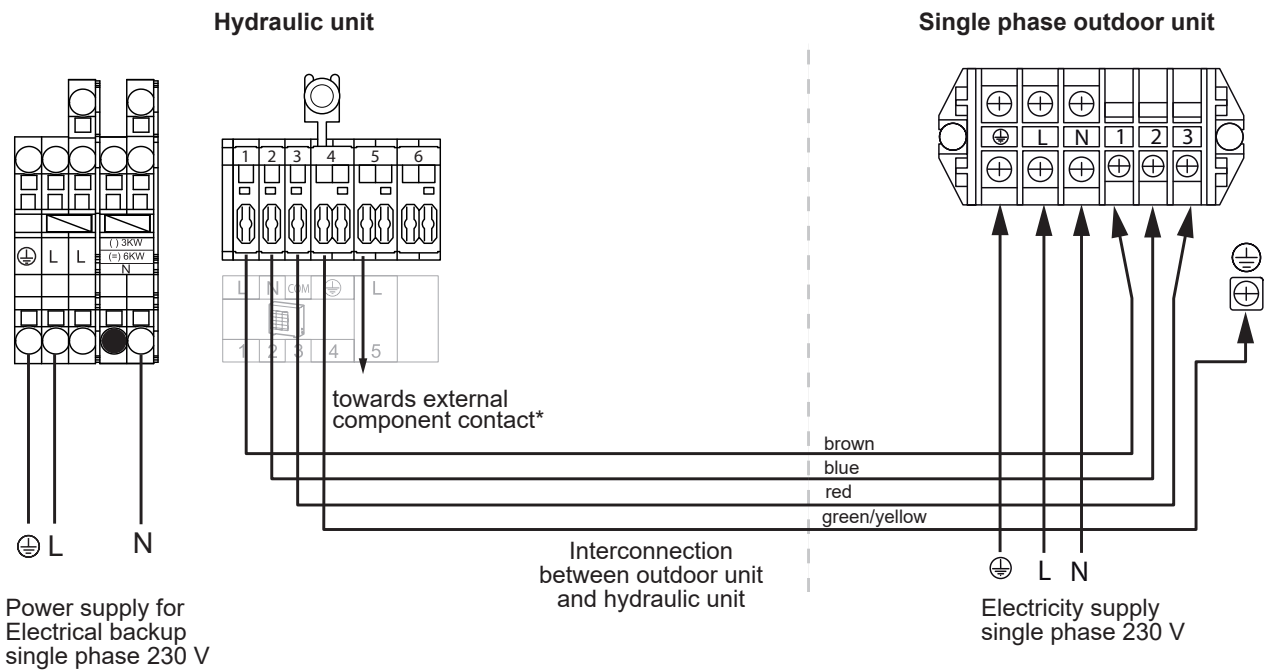

fig. 33 - Cable passages

■ Waterstage SHP 16



■ Waterstage SHP TRI 15
Waterstage SHP TRI 17

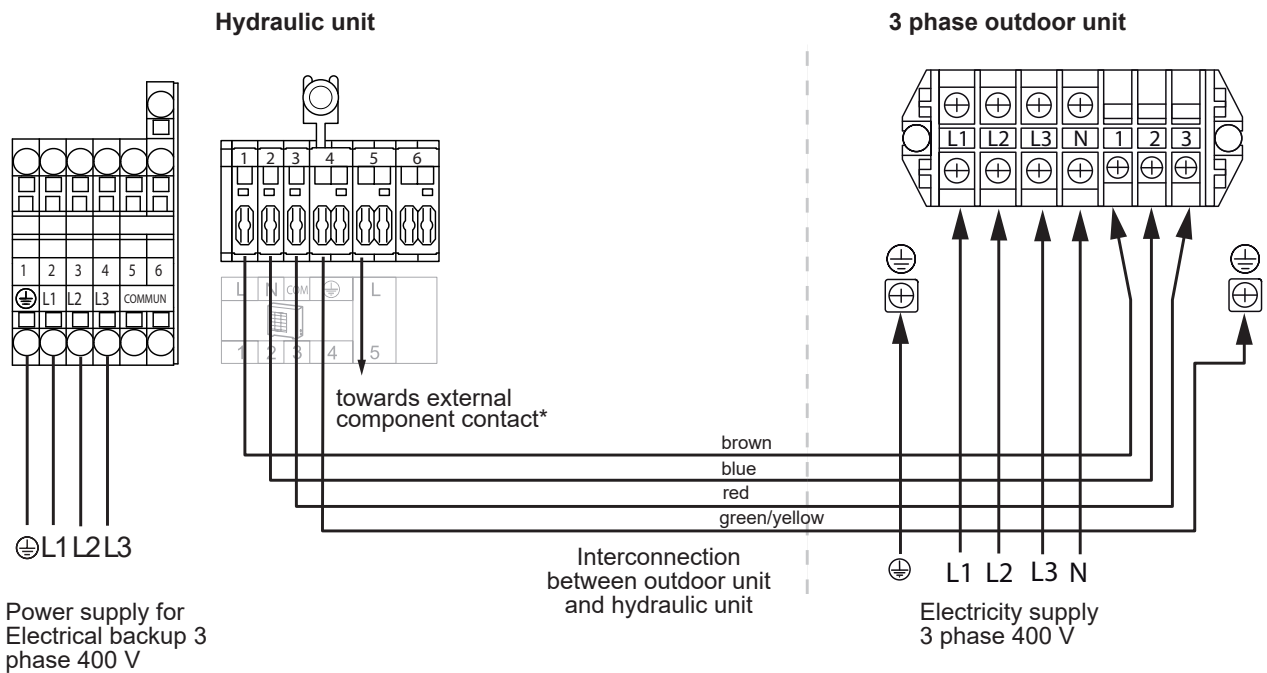
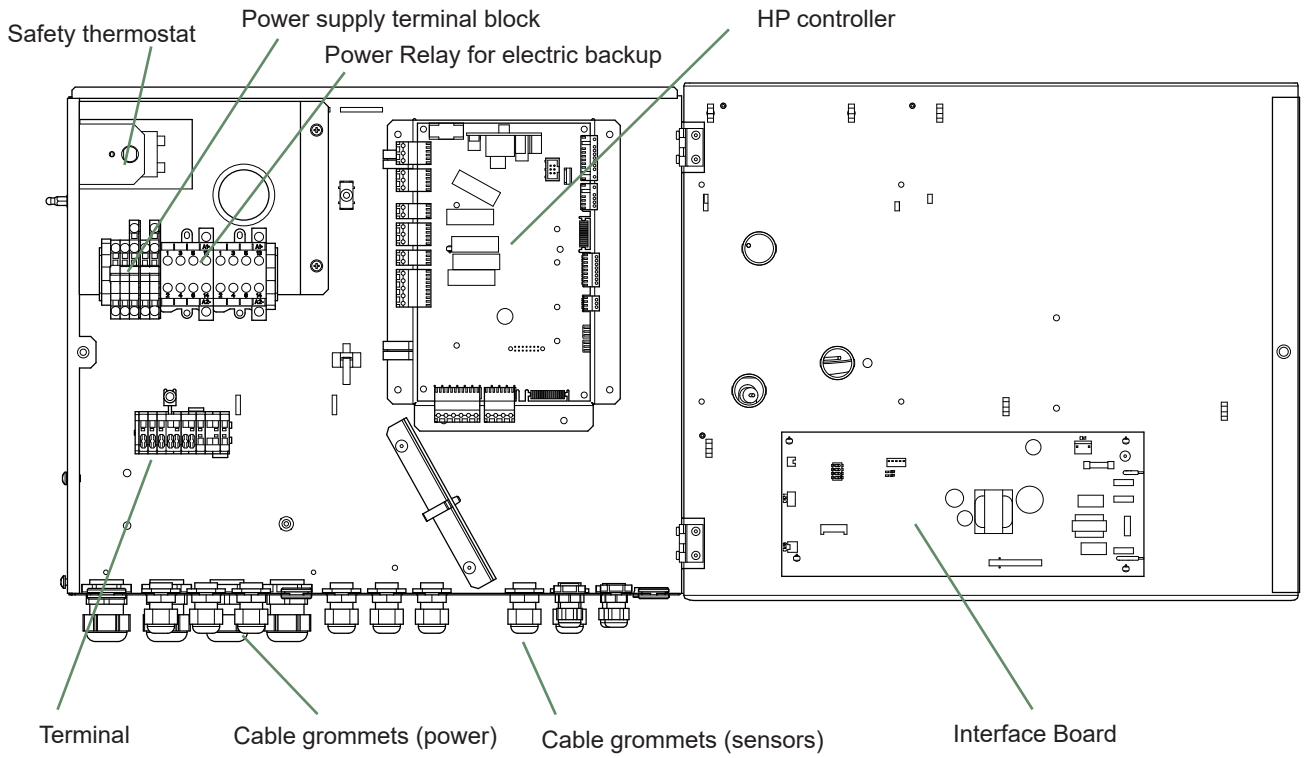

fig. 34 - Connection to terminal blocks and power relay

■ Waterstage SHP 16



■ Waterstage SHP TRI 15
Waterstage SHP TRI 17

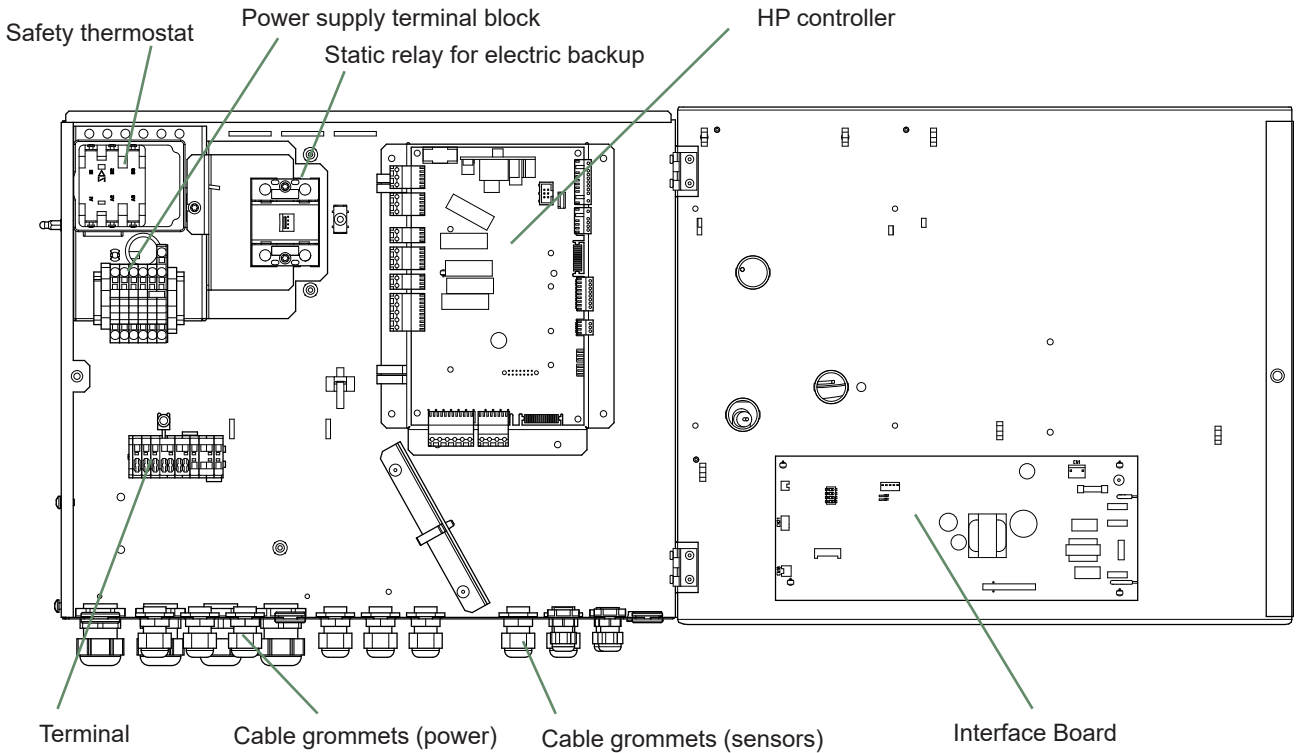

fig. 35 - Description of the hydraulic unit's electrical control box

► Outside sensor

The outside sensor is required for correct operation of the heat pump.

Please see the fitting instructions on the sensor's packaging.

Place the sensor on the coldest side of the building, generally the northern or north-western side.

It must not be exposed to morning sun.

It must be installed so as to be easily accessible but at least 2.5m from the ground.

It is essential that it is not placed near any sources of heat such as flues, upper parts of doors and windows, near extractor vents, under balconies and eaves, or anywhere which would insulate the sensor from variations in the outdoor air temperature.

- Connect the outside sensor to connector **X84** (terminals **M** and **B9**) on the heat pump control board.

► Room sensor (optional)

The room sensor (room unit) is optional.

Please see the fitting instructions on the sensor's packaging.

The sensor must be installed in the living room area on an unobstructed wall. It must be installed so as to be easily accessible.

Avoid direct sources of heat (chimney, television, cooking surfaces, sun) and draughty areas (ventilation, door, etc.).

Draughts in buildings are often brought about by cold air blowing through the electrical ducting. Lag the electrical ducts if there is a cold draught behind the room sensor.

▼ Installing a room sensor

• Room thermostat

- Connect the sensor to the **X86** connector of the heat pump's regulator board using the connector provided (terminals **1, 2**).

• Room thermostat radio

- Please refer to the instructions.

▼ Installing a room control unit

• Room control unit

- Connect the sensor to the **X86** connector of the heat pump's regulator board using the connector provided (terminals **1, 2** and **3**).

• Room control unit radio

- Please refer to the instructions.

▼ Fan convector zone

If the installation is equipped with fan convectors or dynamic radiators, **do not use a room sensor**.

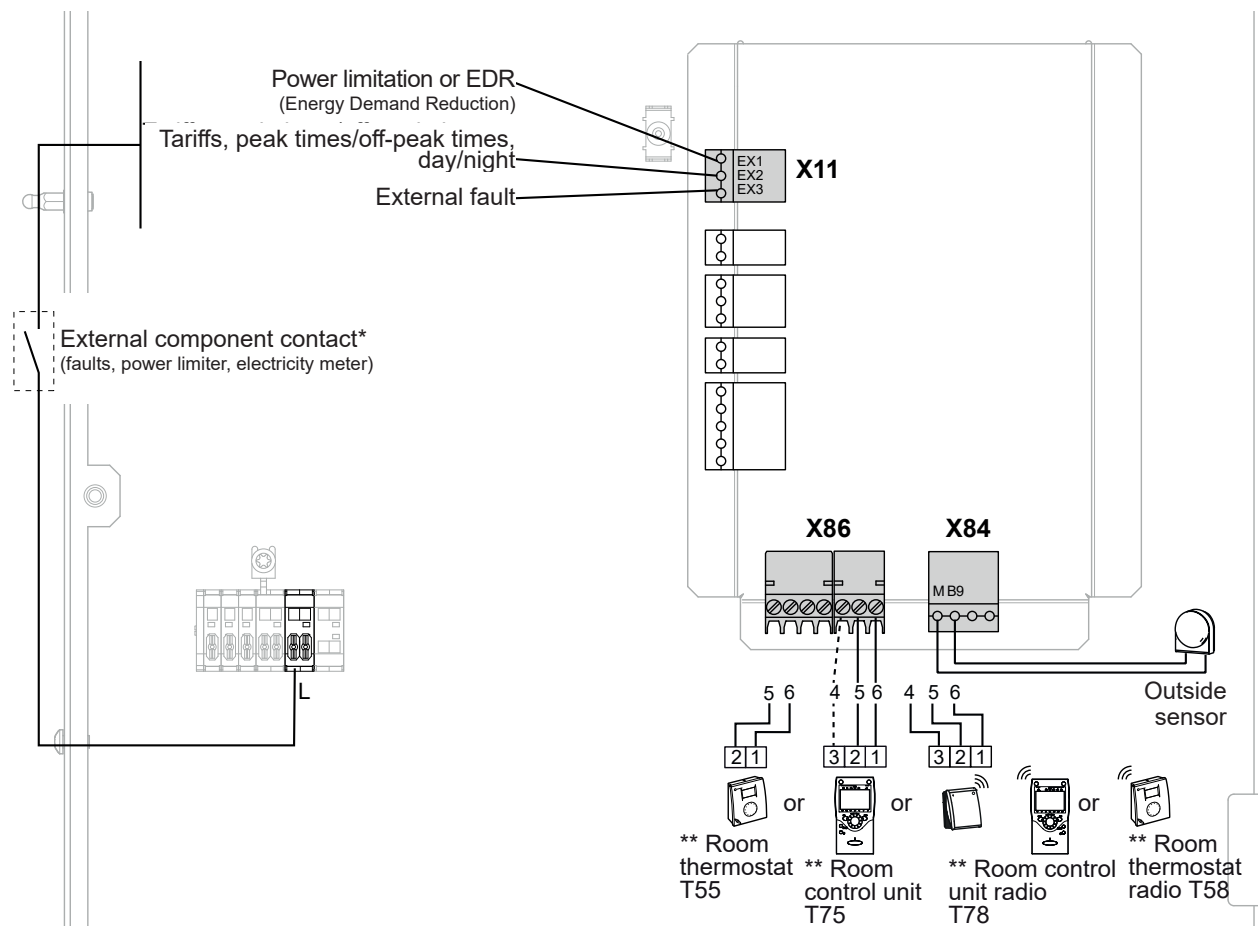

* If the control device does not provide a potential-free contact, the contact must be relayed to create equivalent wiring. In all cases, please refer to the instruction manuals for the external components (load shedder, power meters) to create the wiring.

** Option

The connection of terminal 3 of the room control unit is not mandatory (lighting of the room control unit).

fig. 36 - Connections on the heat pump controller (accessories and options)

Commissioning

- Close the installation's main circuit breaker.

Upon initial start-up (or in winter), to preheat the compressor, engage the installation's main circuit breaker (outdoor unit power supply) several hours before starting any tests.

- Press the heat pump's Start/Stop button.

To ensure that inputs EX1, EX2 and EX3 operate correctly: Check that the electricity supply's neutral phase polarity has been respected.

When the power is switched on and every time that the ON/OFF button is switched off and then switched on again, the outdoor unit will take approximately 4 minutes to start up, even if the setting is requesting heating.

- Engage the start/stop switch.

To ensure that inputs EX1, EX2 and EX3 operate correctly: Check that the live-neutral polarity of the power supply is correct.



When the power is switched on and every time that the ON/OFF button is switched off and then switched on again, the outdoor unit will take approximately 4 minutes to start up, even if the setting is requesting heating.

The display can show error 370 when the appliance (re)starts. Do not be concerned, the communication between the outdoor and hydraulic unit will re-establish itself in a few moments.

During the regulator initialisation phase, the display shows all the symbols and then "Data, update" and then "State heat pump".

- Make all the specific adjustments to the setting. (Installation configuration):

- Press  .

- Hold down the key  for 3s and select the level of access used with the aid of the knob.  .

- Confirm with the key  .

- Parameter the heat pump's setting (Consult the settings' list

On commissioning (or the case of error 10), the electrical back-up heaters are liable to start up even if the outdoor temperature at the time is above the heaters' trigger temperature.

The regulating system uses an average initial outdoor temperature of 0°C and requires some time to update this temperature.

To avoid this situation, the sensor must be connected correctly. Re-initialise parameter 8703 (commissioning level, consumer diagnostic menu).

► Configuring room thermostat (wireless)

To configure the room thermostat and connect it to the appropriate heating zone:

- Hold down the presence key for more than 3 seconds. The room thermostat displays RU and a number flashes.
- Turn the wheel to choose the zone (1, 2).

If the installation is fitted with 2 room thermostats,

- **First connect one room thermostat and configure it in zone 2,**
- **Then connect the other room thermostat and configure it as default in zone 1.**

- Hold down the presence key; the room thermostat displays P1 and a flashing number.
 - 1: Automatic recording: a correction of the setting with the button is adopted without any particular confirmation (timeout) or by pressing the mode key.
 - 2: Recording with confirmation: a correction of the setting with the button is not adopted until the mode key is pressed.

- Press the presence key again; the room thermostat displays P2 and a flashing number.

0: OFF: all the operating elements are engaged.

1: ON: the following operating elements are locked:

- Switching over the heating circuit's operating mode,
- Adjusting the comfort setting,
- Changing the operating level.

The room thermostat displays OFF for 3 seconds when a locked button is pressed.

► Configuring room control unit (wireless)

During commissioning, after an initialisation period of approx. 3 minutes, the user's language must be set:

- Press  .
- Choose menu "Operator section".
- Choose language.
- Select the language (**English**, Deutsch, Français, Italiano, Nederlands, Español, Português, Dansk...).

In the case of 2 heating circuits.

- Choose the allocation of the room control unit (room appliance 1 or 2...) line 40* (see [page 51](#)).
- According to the allocation selected check and, if necessary, modify the settings for lines 42*, 44*, 48* (see [page 51](#)).







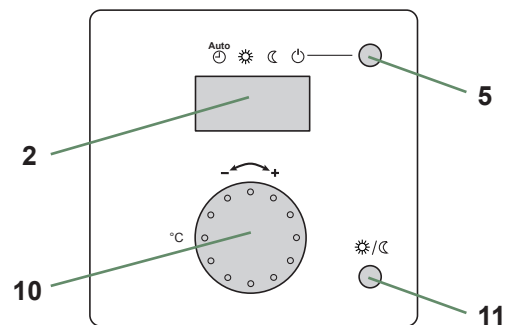
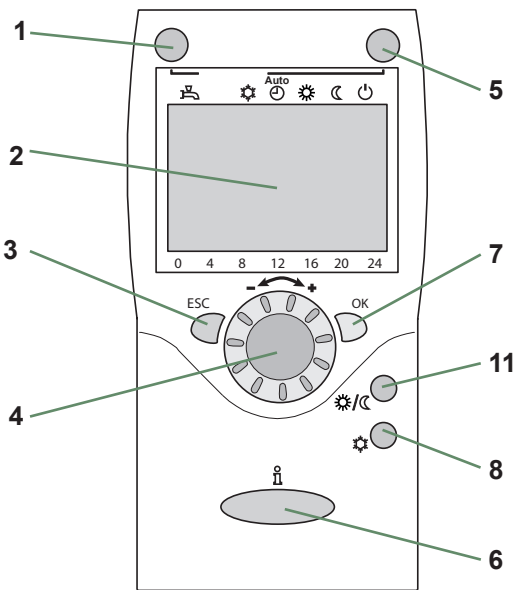
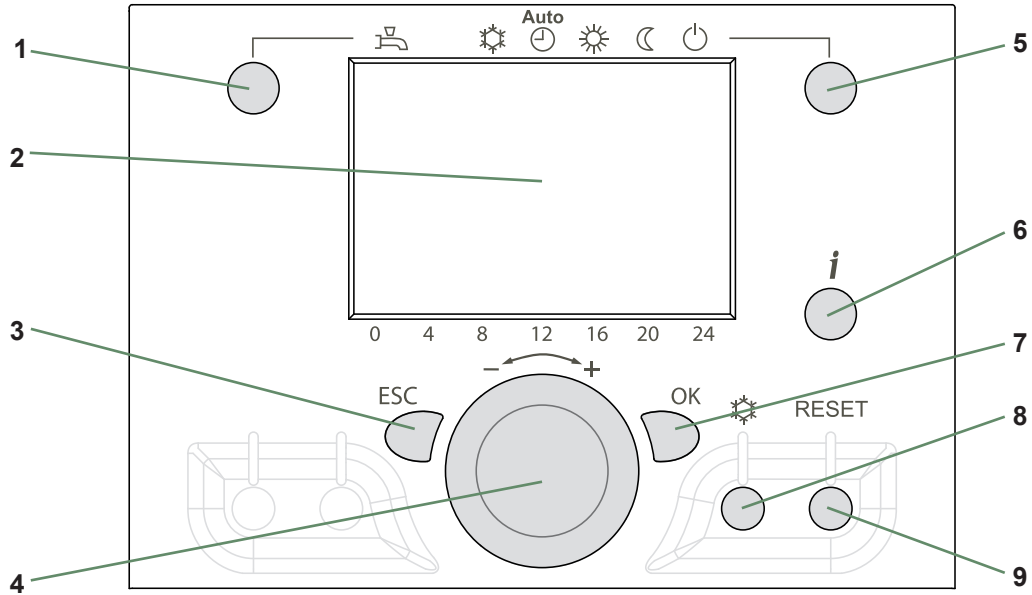

Line	Function	Setting range or display	Setting increment	Basic setting
40	I Use as...	Room appliance 1, 2, P, User interface 1, 2, P, Service appliance		Room appliance 1
	This line regulates the use of the room control unit. (lines 42, 44, 48).		Depending on how it is used, other settings will be necessary	
42	I Appliance allocation 1	Heating circuit 1, Heating circuit 1 & 2, Heating circuit 1 & P, All the heating circuits		Heating circuit 1
44	I Operation HC2 (command HC2)	Commonly with HC1, Independent		Commonly with HC1
	This function enables you to choose whether you wish the room thermostat (as an option) to act on both zones or just a single zone.			
48	I Occupancy control switch function	Without, Heating circuit 1, Heating circuit 2, Common		

* **These parameter lines are only accessible from the room control unit.**

Controller Interface

- The user interface, the central ambient unit (option) and the ambient sensor (option)



Ref.	Functions	- Definition of the functions
1	Selecting the DHW operation  Marche  Arrêt	<ul style="list-style-type: none"> - Start: Production of DHW in function of the timer programme. - Stop: Production of the DHW stopped with antifreeze function of the domestic water active. - Manual start button: Press the DHW button for 3 s (switches from "reduced" to "comfort" until the DHW timer programme is switched again).
2	Digital display	<ul style="list-style-type: none"> - Check the operation, read the current temperature of the heating operation, or a possible fault. - View the settings.
3	"ESC" output	<ul style="list-style-type: none"> - Exit the menu.
4	Navigation and setting	<ul style="list-style-type: none"> - Setting the comfort temperature value. - Menu selection - Setting the parameters.
5	Selecting the heating operation	<ul style="list-style-type: none"> -  Service heating according to the heating programme (automatic summer/winter switching). -  Permanent comfort temperature. -  Permanent reduced temperature. -  "Stand-by" operation with antifreeze protection (provided that the electrical power supply of the heat pump is not interrupted).
6	Displaying information	<ul style="list-style-type: none"> - Miscellaneous information (see "Information display", page 66). -  Reading the error codes (see "Fault Diagnosis", page 74). -  Information on maintenance, special operation.
7	Validation "OK"	<ul style="list-style-type: none"> - Enter the selected menu. - Validate the parameter settings. - Validate the comfort temperature value setting.
8	Selection of the refresh mode	<ul style="list-style-type: none"> -  Service cooling according to the heating programme (automatic summer/winter switching).
9	Reset (Press and relief)	<ul style="list-style-type: none"> - Reset the parameters and cancel the error messages. <p>Do not use during normal operation</p>
10	Setting button	<ul style="list-style-type: none"> - Setting the comfort temperature value.
11	Presence button	<ul style="list-style-type: none"> - Comfort / reduced switching.

► Description of the display

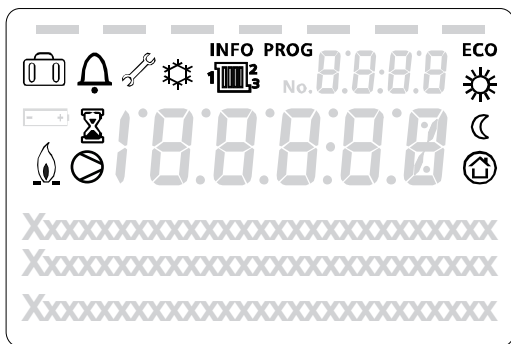

Icons	Definitions
	- Heating mode active with reference to the heating circuit.
	- Heating in comfort mode.
	- Heating in reduced mode.
	- Heating in "standby" mode (antifreeze).
	- Refresh mode active.
	- Holiday function activated.
	- Process in progress.
	- Compressor operation.
	- Burner operation.
	- Default message.
	- Maintenance, special operation
INFO	- Information level activated.
PROG	- Programming activated.
ECO	- ECO function activated (Heating stopped temporarily)



- Time /
Parameter number /
Setpoint value.



- Ambient temperature /
Setpoint value.



- Setpoint information /
Parameter information.

► Temperature control

The heat pump's operation is subject to the temperature control.

The heating circuit water temperature setpoint is adjusted according to the outdoor temperature.

If there are thermostatic valves on the installation, these must be fully open or set higher than the normal temperature setpoint.

▼ Setting

During the installation, the temperature control must be configured to suit the radiators and level of insulation of the dwelling.

The temperature control graphs (fig. 37) refer to a room temperature setpoint of 20°C.

The temperature control's gradient determines the impact of variations in the outdoor temperature on variations in the heating flow temperature.

The steeper the gradient, the more likely a slight reduction in the outdoor temperature will cause a significant increase in the water flow temperature in the heating circuit.

The temperature control off-set modifies the flow temperature of all graphs, without modifying the gradient (fig. 38).

Corrective actions to take in the case of discomfort are listed in the table (fig. 39).

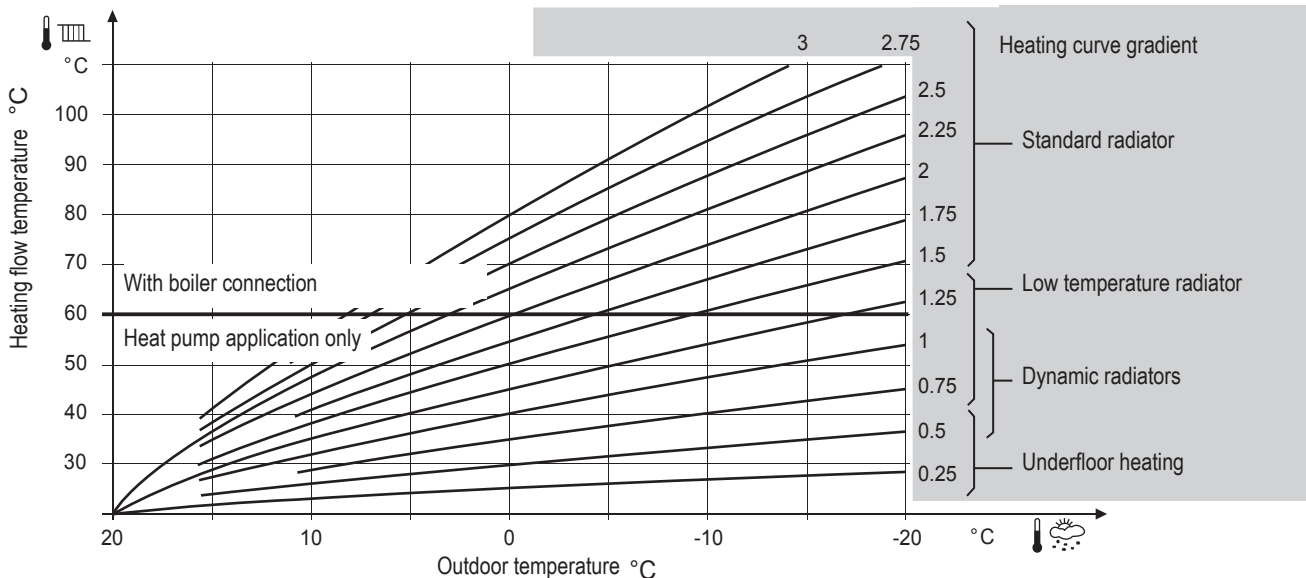

fig. 37 - Heating curve gradient

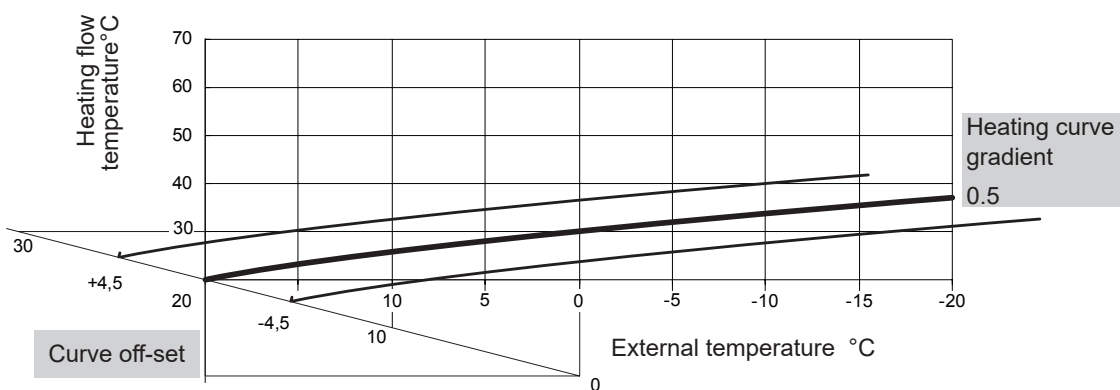

fig. 38 - Transferral of the heating curve

Sensations...		Corrective actions on the temperature control:	
...in mild weather	...in cold weather	Gradient	Off-set
Good	& Good	→ No correction	No correction
Cold	& Hot	→	
Cold	& Good	→	
Cold	& Cold	→ No correction	
Good	& Hot	→	No correction
Good	& Cold	→	No correction
Hot	& Hot	→ No correction	
Hot	& Good	→	
Hot	& Cold	→	

fig. 39 - Corrective actions in case of discomfort

Controller Menu

▼ General

Only the parameters accessible at the levels:

U - end user.

I - Commissioning

S - Specialist.

are described in this document.

The access levels are specified in the second column of the table by means of the letters **U**, **I** and **S**.

The OEM parameters are not described and require a manufacturer access code.

▼ Setting parameters

- Selecting the desired level.
- Scroll the list of menus.
- Selecting the desired menu.
- Scroll the function lines.
- Selecting the desired line.
- Adjusting the parameter.
- Validate the setting by pressing **OK**.
- To return to the menu, press **ESC**.

If no setting is made for 8 minutes, the screen automatically returns to the basic display.

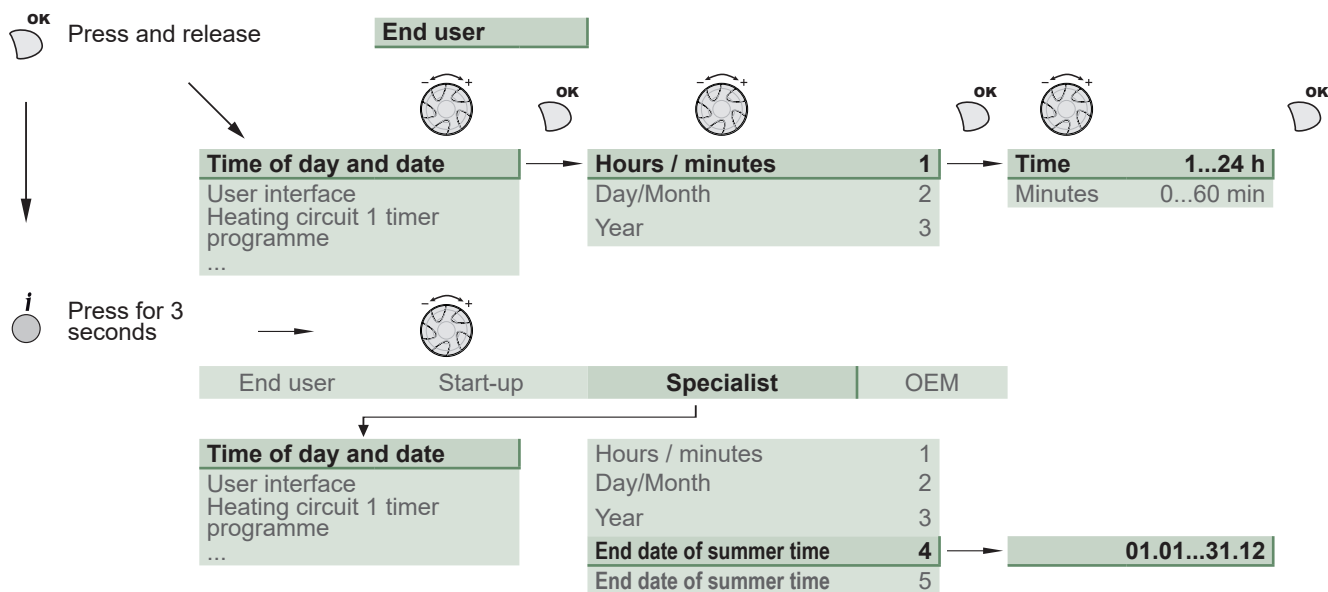

▼ Recommended settings for the parameters depending on the installation's emitters

		Very Low Temperature Radiators / Heating-cooling floor	Low temperature radiators	Dynamic radiators or fan-coil heaters	Classic temperature radiators
Heating curve slope	720 (CC1) 1020 (CC2)	0.25 to 0.5	0.5 to 1.25	0.4 to 1.1	1.25 to 3
Curve displacement	721 (CC1) 1021 (CC2)	0	0	4 *	0
Min. outgoing value	740 (CC1) 1040 (CC2)	Factory (17 °C)	Factory (17 °C)	30 or 35 °C	Factory (17 °C)
Max. initial setpoint	741 (CC1) 1041 (CC2)	50 °C	Factory (55 °C)	65 °C	65 °C
DHW charging time limitation	5030	Factory (90 min)	Factory (90 min)	40 min	Factory (90 min)

► List of function lines

<i>Line</i>	<i>Function</i>	<i>Setting range or display</i>	<i>Setting increment</i>	<i>Basic setting</i>
Time of day and date				
1	U Hours / Minutes	00:00... 23:59	1	
2	U Day / Month	01.01... 31.12	1	
3	U Year	1900... 2099	1	
5	S Start of Summer time (Day / Month)	01.01... 31.12	1	25.03
6	S End of Summer time (Day / Month)	01.01... 31.12	1	25.10
The change of hour will appear at 3:00 first Sunday after the regulated date.				
Operator Section				
20	U Language	English, Français, Italiano, Nederlands...		English
22	S Info	Temporary, Permanent		Temporary
26	S Operation locking	On, Off		Off
27	S Programming locking	Off, On		Off
28	I Direct setting	Automatic storage, With confirmation		With confirmation
29	I Temperature units Pressure units	°C, °F bar, psi		°C bar
44	I Operation HC2	Jointly with HC1 Independently		Jointly with HC1
46	I Operation HC3/P	Jointly with HC1 Independently		Jointly with HC1
70	S Display software version			
Time program heating / cooling, circuit 1				
500	U Pre-selection (Day / Week)	Mon-Sun, Mon-Fri, Sat-Sun, Monday, Tuesday, ...		Mon-Sun
501	U 1st phase On (start)	00:00... --:--	10 min	6:00
502	U 1st phase Off (end)	00:00... --:--	10 min	22:00
503	U 2nd phase On (start)	00:00... --:--	10 min	--:--
504	U 2nd phase Off (end)	00:00... --:--	10 min	--:--
505	U 3rd phase On (start)	00:00... --:--	10 min	--:--
506	U 3rd phase Off (end)	00:00... --:--	10 min	--:--
516	U Default values, Circuit 1	No, Yes		No

Yes + OK: The default values memorised in the regulator replace and cancel the customised heating programs. Your customised settings are therefore lost.

<i>Line</i>	<i>Function</i>	<i>Setting range or display</i>	<i>Setting increment</i>	<i>Basic setting</i>
Time program heating / cooling, circuit 2				
Only with the 2nd circuit kit option.				
520	U Pre-selection (Day / Week)	Mon-Sun, Mon-Fri, Sat-Sun, Monday, Tuesday, ...		Mon-Sun
521	U 1st phase On (start)	00:00... --:--	10 min	6:00
522	U 1st phase Off (end)	00:00... --:--	10 min	22:00
523	U 2nd phase On (start)	00:00... --:--	10 min	--:--
524	U 2nd phase Off (end)	00:00... --:--	10 min	--:--
525	U 3rd phase On (start)	00:00... --:--	10 min	--:--
526	U 3rd phase Off (end)	00:00... --:--	10 min	--:--
536	U Default values, Circuit 2	No, Yes		No
Yes + OK: The default values memorised in the regulator replace and cancel the customised heating programs. Your customised settings are therefore lost.				
Time program 4 / DHW				
If the installation is fitted with the DHW kit.				
560	U Pre-selection (Day / Week)	Mon-Sun, Mon-Fri, Sat-Sun, Monday, Tuesday, ...		Mon-Sun
561	U 1st phase On (start)	00:00... --:--	10 min	00:00
562	U 1st phase Off (end)	00:00... --:--	10 min	05:00
563	U 2nd phase On (start)	00:00... --:--	10 min	14:30
564	U 2nd phase Off (end)	00:00... --:--	10 min	17:00
565	U 3rd phase On (start)	00:00... --:--	10 min	--:--
566	U 3rd phase Off (end)	00:00... --:--	10 min	--:--
576	U Default values	No, Yes		No
Yes + OK: The default values memorised in the regulator replace and cancel the customised heating programs. Your customised settings are therefore lost.				
Holidays, heating circuit 1 (For the Holiday program is active, the heating mode should be on AUTO).				
641	U Preselection	Period 1 to 8		Period 1
642	U Period Start (Day / Month)	01.01... 31.12	1	
643	U Period End (Day / Month)	01.01... 31.12	1	
648	U Operating level	Frost protection, Reduced		Frost protection
Holidays, heating circuit 2 (For the Holiday program is active, the heating mode should be on AUTO).				
If the installation consists of 2 heating circuits (Only with the 2nd circuit kit option).				
651	U Preselection	Period 1 to 8		Period 1
652	U Period Start (Day / Month)	01.01... 31.12	1	
653	U Period End (Day / Month)	01.01... 31.12	1	
658	U Operating level	Frost protection, Reduced		Frost protection

Line	Function	Setting range or display	Setting increment	Basic setting
Heating adjustment, circuit 1				
710	U Comfort setpoint	Reduced setpoint... Comfort setpoint maximum	0.5 °C	20 °C
712	U Reduced setpoint	Frost protection setpoint... Comfort setpoint	0.5 °C	19 °C
714	U Frost protection setpoint	4 °C... Reduced setpoint	0.5 °C	8 °C
716	S Comfort setpoint maximum	20 °C... 35 °C	1 °C	28 °C
720	I Heating curve slope	0.1... 4	0.02	0.5
	(see "Recommended settings for the parameters depending on the installation's emitters", page 50 & fig. 37, page 49)			
721	I Off-set of the heating curve (fig. 38, page 49)	-4.5 °C... 4.5 °C	0.5 °C	0
730	I Summer / Winter heating limits	8 °C... 30 °C	0.5 °C	18 °C
	When the average of the Outdoor temperatures over the past 24 hours reaches 18°C, the regulator switches off the heating (as an economy measure). During summer mode, the display shows "Eco". This function is only active in automatic mode.			
740	I Flow temp setpoint min	8 °C... Flow temp setpoint max	1 °C	17 °C
	(with dynamic radiator, adjust from 30 to 35°C)			
741	I Flow temp setpoint max	Flow temp setpoint min... 70 °C	1 °C	60 °C
	Floor heating system = 50 °C / Radiators = 65 °C. Important Note : Maximum temperature limitation is not a safety function as required by ground heating.			
750	S Room influence	1%... 100%	1%	50%
	If the installation is fitted with a room thermostat: This function enables you to choose the ambient temperature's influence on the setting. If no value is entered, the setting is made based on the temperature control. If the parameter is set at 100%, the setting is only based on the ambient temperature.			
760	S Room temperature limitation	0.5... 4 °C	0.5 °C	0.5 °C
	As soon as the room temperature = [Setpoint line 710 (ex. 20°C) + Room temperature limitation setpoint line 760 (ex. 0.5 °C)] > 20.5 °C => The heat pump is stopped. It restarts when the room temperature falls below the setpoint (in the example, Room temperature < 20.0 °C).			
780	S Quick setback	Off, Down to reduced setpoint, Down to frost prot setpoint		Off
790	S Optimum start control max (Early start to switch to the comfort setting.)	0... 360 min	10 min	180 min
791	S Optimum stop control max (Early stop to switch from the comfort setting to the reduced setting.)	0... 360 min	10 min	30 min
800	S Reduced setpoint increase start	-30... 10 °C	1 °C	--
801	S Reduced setpoint increase end	-30... 10 °C	1 °C	-5 °C
830	S Mixer valve boost	0... 50 °C	1 °C	0 °C
834	S Actuator running time	30... 873 s	1 s	240 s

Line	Function	Setting range or display	Setting increment	Basic setting
850	I Floor curing function (fig. 40)			Off
	<ul style="list-style-type: none"> - Off: Early interruption of the current programme, programme inactive. - Operational heating. - Heating ready for occupation. - Operational heating + ready heating. - Ready heating + operational heating. - Manual: Manual mode enables you to programme your own concrete slab drying time. The function ends automatically after 25 days. 			

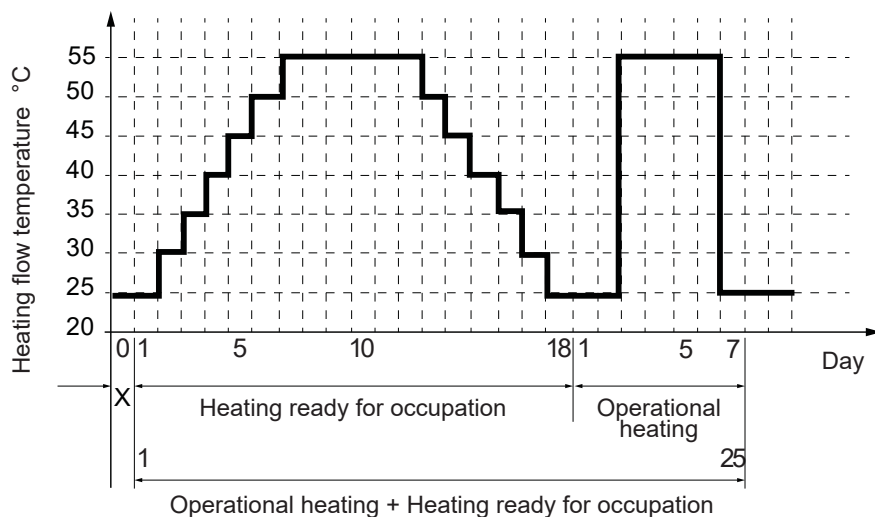

Please comply with the standards and instructions of the manufacturer of the building ! A good performance of this function is only possible with an installation correctly implemented (hydraulic, electricity and adjustments) ! This function can be stopped by anticipation when setting the adjustment on "Off".

fig. 40 - Diagram of the concrete slab drying programmes

851	I	Floor curing setpoint manually (if line 850 = manual)	0... 95 °C	1 °C	25 °C
	This function enables you to set the custom concrete slab drying temperature. This temperature remains fixed. The concrete slab-drying programme stops automatically after running for 25 days.				
856	I	Floor curing day current	0... 32		
857	I	Floor curing day completed	0... 32		
900	S	Operating mode changeover	None, Protection mode, Reduced, Comfort, Automatic	1	Reduced
	Operating mode at end of concrete slab drying period				

Cooling circuit 1

If the installation is fitted with the cooling kit (Only with the cooling kit option).

901	U	Operating mode	Protection, Automatic, Reduced, Comfort		Protection
902	U	Comfort cooling setpoint	17... 40 °C	0,5 °C	24 °C
903	U	Reduced setpoint	5... 40 °C		26 °C
908	I	Flow temp setp at OT° 25°C	6... 35 °C	0,5 °C	20 °C
909	I	Flow temp setp at OT° 35°C	6... 35 °C	0,5 °C	16 °C
912	I	Cooling limit at OT°	8... 35 °C	0,5 °C	24 °C
913	S	Lock time at end of heating / cooling	8... 100	1 h	24 h
918	S	Summer comp start at OT°	20... 50 °C	1 °C	26 °C
919	S	Summer comp end at OT°	20... 50 °C	1 °C	40 °C
920	S	Summer comp setp increase	1... 10 °C	1 °C	4 °C
923	S	Flow temp setp min OT° 25°C	6... 35 °C	0,5 °C	18 °C
924	S	Flow temp setp min OT° 35°C	6... 35 °C	0,5 °C	18 °C

Line	Function	Setting range or display	Setting increment	Basic setting
928	S Room influence If the installation is fitted with a room thermostat: This function enables you to choose the ambient temperature's influence on the setting. If no value is entered, the setting is made based on the temperature control. If the parameter is set at 100%, the setting is only based on the ambient temperature.	1... 100 %	1 %	80 %
932	S Room temp limitation	0,5... 4 °C	0,5 °C	0,5 °C
938	S Mixing valve decrease	0... 20 °C	1 °C	0 °C
941	S Actuator running time	30... 873 s	1 s	240 s
963	S With prim contr / system pump *Basic setting : 1 circuit = No ; 2 circuits = Yes.	No, Yes		No*
Heating adjustment, Circuit 2				
Only with the 2nd circuit kit option (If the installation consists of 2 heating circuits).				
1010	U Comfort setpoint	Reduced setpoint... Comfort setpoint maximum	0.5 °C	20 °C
1012	U Reduced setpoint	Frost protection setpoint... Comfort setpoint	0.5 °C	19 °C
1014	U Frost protection setpoint	4 °C... Reduced setpoint	0.5 °C	8 °C
1016	S Comfort setpoint maximum	Comfort temp... 35 °C	1 °C	28 °C
1020	I Heating curve slope (see "Recommended settings for the parameters depending on the installation's emitters", page 50 & fig. 37, page 49)	0.1... 4	0.02	0.5
1021	I Off-set of the heating curve (fig. 38, page 49)	-4.5... 4.5 °C	0.5 °C	0 °C
1030	I Summer / Winter heating limits When the average of the outdoor temperatures over the past 24 hours reaches 18°C, the regulator switches off the heating (as an economy measure). During summer mode, the display shows "Eco". This function is only active in automatic mode.	8... 30 °C	0.5 °C	18 °C
1040	I Flow temp setpoint min (with dynamic radiator, adjust from 30 to 35°C)	8... 70 °C	1 °C	17 °C
1041	I Flow temp setpoint max Floor heating system = 50 °C / Radiators = 65 °C. Important Note : Maximum temperature limitation is not a safety function as required by ground heating.	8... 70 °C	1 °C	60 °C
1050	S Room influence If the installation is fitted with a room thermostat: This function enables you to choose the ambient temperature's influence on the setting. If no value is entered, the setting is made based on the temperature control. If the parameter is set at 100%, the setting is only based on the ambient temperature.	1 %... 100 %	1 %	50 %
1060	S Room temperature limitation As soon as the room temperature = [Setpoint line 1010 (ex. 20°C) + Room temperature limitation setpoint line 1060 (ex. 0,5 °C)] > 20,5 °C => The heat pump is stopped. It restarts when the room temperature falls below the setpoint (in the example, Room temperature < 20,0 °C).	0.5... 4 °C	0.5 °C	0.5 °C
1080	S Quick setback	Off, Down to reduced setpoint, Down to frost prot setpoint		Off
1090	S Optimum start control max	0... 360 min	10 min	180 min
1091	S Optimum stop control max	0... 360 min	10 min	30 min
1100	S Reduced setpoint increase start	-30... 10 °C, --°C	1 °C	--
1101	S Reduced setpoint increase end	-30... 10 °C, --°C	1 °C	-5 °C
1130	S Mixer valve increase	0... 50 °C	1 °C	0 °C
1134	S Actuator running time	30... 873 s	1 s	240 s

<i>Line</i>	<i>Function</i>	<i>Setting range or display</i>	<i>Setting increment</i>	<i>Basic setting</i>
1150	I Floor curing function (fig. 40, page 54) - Off: Early interruption of the current programme, programme inactive. - Operational heating. - Heating ready for occupation. - Operational heating + ready heating. - Ready heating + operational heating. - Manual: Manual mode enables you to programme your own concrete slab drying time. The function ends automatically after 25 days.			Off
1151	I Floor curing setpoint manually (if line 1150 = manual) This function enables you to set the custom concrete slab drying temperature. This temperature remains fixed. The concrete slab-drying program stops automatically after running for 25 days.	0... 95 °C	1 °C	25 °C
1156	I Floor curing day current	0... 32		
1157	I Floor curing day completed	0... 32		0
1200	S Operating mode changeover Operating mode at end of concrete slab drying period.	None, Protection mode, Reduced, Comfort, Automatic		Reduced
Cooling circuit 2				
If the installation is fitted with the cooling kit (Only with the cooling kit option).				
1201	U Operating mode	Protection, Automatic, Reduced, Comfort		Protection
1202	U Comfort cooling setpoint	17... 40 °C	0.5 °C	24 °C
1203	U Reduced setpoint	5... 40°C		26 °C
1208	I Flow temp setp at OT° 25°C	6... 35 °C	0.5 °C	20 °C
1209	I Flow temp setp at OT° 35°C	6... 35 °C	0.5 °C	16 °C
1212	I Cooling limit at OT°	8... 35 °C	0.5 °C	24 °C
1213	S Lock time at end of heating / cooling	8... 100	1 h	24 h
1218	S Summer comp start at OT°	20... 50 °C	1 °C	26 °C
1219	S Summer comp end at OT°	20... 50 °C	1 °C	40 °C
1220	S Summer comp setp increase	1... 10 °C	1 °C	4 °C
1223	S Flow temp setp min OT° 25°C	6... 35 °C	0.5 °C	18 °C
1224	S Flow temp setp min OT° 35°C	6... 35 °C	0.5 °C	18 °C
1228	S Room influence If the installation is fitted with a room thermostat: This function enables you to choose the ambient temperature's influence on the setting. If no value is entered, the setting is made based on the temperature control. If the parameter is set at 100%, the setting is only based on the ambient temperature.	1... 100 %	1 %	80 %
1232	S Room temp limitation	0.5... 4 °C	0.5 °C	0.5 °C
1238	S Mixing valve decrease	0... 20 °C	1 °C	0 °C
1241	S Actuator running time	30... 873 s	1 s	240 s
1263	S With prim contr / system pump	No, Yes		No*

*Basic setting : 1 circuit = No ; 2 circuits = Yes.

Line	Function	Setting range or display	Setting increment	Basic setting
Domestic hot water				
If the installation is fitted with the DHW kit.				
1600	U	Operating mode	Off, On, Eco	On
1610	U	Nominal setpoint	Reduced setpoint (line 1612)... 65 °C	1 55 °C
The backup electrical system is required to reach this level.				
1612	U	Reduced setting	8 °C... Nominal setting (line 1610)	1 40 °C
1620	I	Release of DHW load	24h / day Heating circuit time programme Programme 4 / DHW Off-peak tariff (Off-peak) Programme 4 / DHW and Off-peak	Programme 4 / DHW
24h / day: The temperature of the DHW is constantly maintained at the DHW comfort setting.				
Heating circuit time programme: The DHW is produced according to the programming for the ambient temperature (with 1 hour in advance when switched on).				
Programme 4 / DHW: The DHW programme is separate form the heating circuit programme.				
Off-peak tariff* : The electrical backup heating is only authorised to operate during the off-peak period.				
T'prog 4/DHW or low-tariff* : The electrical backup heating is authorised to operate during the comfort period or off peak.				
* - Connect the "Power Provider" contact to input EX2 (see fig. 36, page 43). In the case of a day /night contract, the electric back-ups for the DHW tank are subject to the power supplier's tariffs. Switching on the electric back-up for the DHW tank is only authorised during off-peak hours.				
1640	I	Legionella function	Off, Periodically (depending line setting 1641), Fixed weekday (depending line setting 1642)	Off
1641	I	Legionella function periodically	1 to 7	1 day 7
1642	S	Legionella function weekday	Monday, Tuesday,...	Saturday
1644	S	Legionella funct time		
1645	S	Legionella funct setpoint		
1646	S	Legionella funct duration		
1647	S	Legionella funct circ pump	Off, On	Off
1660	S	Circulating pump release	Time program 3/HCP, DHW release, Time program 4/DHW, Time program 5	DHW release
Swimming pool (Only with swimming pool kit option)				
2055	U	Setpoint solar heating	8... 80 °C	26 °C
2056	U	Setpoint source heating	8... 35 °C	22 °C
2057	S	Swi diff source heating	0.5... 3 °C	0.5 °C
2065	S	Charging priority solar	Priority 1, Priority 2, Priority 3	Priority 1
2080	S	With solar integration	No, Yes	Yes

<i>Line</i>	<i>Function</i>	<i>Setting range or display</i>	<i>Setting increment</i>	<i>Basic setting</i>
Heat pump (HP)				
2803	S Overrun time cond pump	8... 240 s	1 s	240s
2843	S Compressor off time min	0... 120 min	1 min	8 min
2844	S Switch-off temp max	8... 100 °C	1 °C	75 °C
2862	S Locking time stage 2 / mod	0... 40 min	1 min	5 min
2873	S Compressor mod run time	10... 600 s	1 s	240 s
2882	S Release integr electric flow	0... 500 °Cmin	1 °Cmin	100 °Cmin
2884	S Release el flow below OT Electrical release - start-up with outdoor temperature	-30... 30 °C		2 °C
2899	I Min flow switch consumers	1...1200 l/h	1 l/h	600 l/h
2916	S Max setpoint HP DHW charg	8... 80 °C		60 °C
2920	S With electrical utility lock (EX1)	Locked (Blocked on standby), Released		Released
Released : HP = ON _ Back-up DHW = off _ 1st back-up HP = off _ 2nd back-up HP = off _ Boiler = ON Locked (Blocked on standby) : HP = off _ Back-up DHW = off _ 1st back-up HP = off _ 2nd back-up HP = off _ Boiler = ON				
Energy meter				
3095 --> 3110 : Not used				
3113	U Energy brought in		Kwh	--
Cumulation of total consumed electrical energy.				
Electrical energy consumed = Electrical energy absorbed by outdoor unit + electric energy absorbed by the heating electrical backup and / or DHW electrical backup (if installed).				
3121 --> 3123 : Not used				
3124	U Energy brought in heating 1 (N - 1)		Kwh	--
3125	U Energy brought in DHW 1		Kwh	--
3126	U Energy brought in cooling 1		Kwh	--
3128 --> 3130 : Not used				
3131	U Energy brought in heating 2 (N - 2)		Kwh	--
3132	U Energy brought in DHW 2		Kwh	--
3133	U Energy brought in cooling 2		Kwh	--
3135 --> 3137 : Not used				
3138	U Energy brought in heating 3 (N - 3)		Kwh	--
3139	U Energy brought in DHW 3		Kwh	--
3140	U Energy brought in cooling 3		Kwh	--
3142 --> 3144 : Not used				
3145	U Energy brought in heating 4 (N - 4)		Kwh	--
3146	U Energy brought in DHW 4		Kwh	--
3147	U Energy brought in cooling 4		Kwh	--
3149 --> 3151 : Not used				
3152	U Energy brought in heating 5 (N - 5)		Kwh	--
3153	U Energy brought in DHW 5		Kwh	--
3154	U Energy brought in cooling 5		Kwh	--

Line	Function	Setting range or display	Setting increment	Basic setting
3156 --> 3158 : Not used				
3159	U Energy brought in heating 6 (N - 6)		Kwh	--
3160	U Energy brought in DHW 6		Kwh	--
3161	U Energy brought in cooling 6		Kwh	--
3163 --> 3165 : Not used				
3166	U Energy brought in heating 7 (N - 7)		Kwh	--
3167	U Energy brought in DHW 7		Kwh	--
3168	U Energy brought in cooling 7		Kwh	--
3170 --> 3172 : Not used				
3173	U Energy brought in heating 8 (N - 8)		Kwh	--
3174	U Energy brought in DHW 8		Kwh	--
3175	U Energy brought in cooling 8		Kwh	--
3177 --> 3179 : Not used				
3180	U Energy brought in heating 9 (N - 9)		Kwh	--
3181	U Energy brought in DHW 9		Kwh	--
3182	U Energy brought in cooling 9		Kwh	--
3184 --> 3186 : Not used				
3187	U Energy brought in heating 10 (N - 10)		Kwh	--
3188	U Energy brought in DHW 10		Kwh	--
3189	U Energy brought in cooling 10		Kwh	--
3190	S Reset fixed day storage	No, Yes		No
Reset the historical counters (1 to 10). The general counter (parameter 3113) is not reset.				
3197	S Compressor electrical power	0.1...60	0.1	See table below

Set the parameter 3197 according to the outdoor unit

Heat Pump	Outdoor unit	Parameter 3197
Waterstage SHP 16	WOYG160LJL	5.37
Waterstage SHP TRI 15	WOYK150LJL	4.55
Waterstage SHP TRI 17	WOYK170LJL	5.32

3264 --> 3267 : Not used

Note: "Energy" Counters increment as of 1 July each year.

Line	Function	Setting range or display	Setting increment	Basic setting
Additional generator (Boiler connection)				
3692	S With DHW charging	Locked, Substitute, Complement, Instantly		Substitute
	<p>- DHW Instantly : When DHW request, the HP and the boiler are put into operation. The HP will stop when the primary return temperature is over 55 °C.</p> <p>- DHW Substitute : If the outdoor temperature is above 2 °C, the operation of the HP when DHW request last 5 minutes at least. The HP operating time can be extended depending on the outdoor temperature. The boiler will activate then.</p>			
3700	S Release below outdoor temperature	-50... 50 °C	1 °C	2 °C
3701	S Release above outdoor temperature	-50... 50 °C	1 °C	--
3705	S Overrun time	0... 120 min	1 min	20 min
3720	S Switching integral (for boiler relief)	0... 500 °Cmin	1 °Cmin	100 °Cmin
3723	S Locking time	1... 120 min	1 min	30 min
Domestic hot water (DHW)				
	If the installation is fitted with the DHW kit.			
5024	S Switching diff	0... 20 °C	1 °C	7 °C
5030	S Charging time limitation	10... 600 min	10 min	90 min
	(with dynamic radiator, adjust 40 min)			
5055	S Recooling temp	10... 95 °C	1 °C	65 °C
5057	S Recooling collector	Off, Summer, Always		Summer
5061	S Electric immersion heater release	24h / day, Release of DHW, Programme 4 / DHW		Release of DHW
5093	S With solar integration	No, Yes		Yes
Installation configuration				
5700	I Pre-setting	1,2,3,... 9	1	1
	<p>This control enables you to choose one of the 4 pre-selected installation configurations. The hydraulic layouts for the various configurations are detailed in the section: "Installation Configurations".</p> <ul style="list-style-type: none"> - Pre-setting 1: 1 heating circuit with or without electrical back-up, with DHW tank. - Pre-setting 2: 2 heating circuits with or without electrical back-up, with DHW tank. - Pre-setting 3: Boiler connection and 1 heating circuit and DHW tank. - Pre-setting 4: Boiler connection and 2 heating circuits and DHW tank. - Pre-setting 5 and more: Not used. 			
5710	S Heating circuit 1	Off, On		On
5711	S Cooling circuit 1	Off, 4-pipe system cooling, 2-pipe system cooling		Off
	Set the parameter to " 2-pipe system cooling " with the cooling kit.			
5715	S Heating circuit 2	Off, On		On
5716	S Cooling circuit 2	Off, 4-pipe system cooling, 2-pipe system cooling		Off
	Set the parameter to " 2-pipe system cooling " with the cooling kit. If the installation consists of 2 heating circuits.			
5731	S DHW controlling element Q3	No charging request, Charging pump, Diverting valve		Diverting valve
5740	S Output el imm heater K6	0,1... 99 kW		2
	5740 = Value of the DHW electrical backup - kW			
5806	I Type el imm heater flow	1 : 3-stage, 2 : 2-stage excluding, 3 : 2-stage complementary, 4 : Modulating UX		3 : 2-stage complementary
5811	S Output el imm heater K25	0,1-...99		3
	Without electrical backup = 0 ; Single phase electrical backup (Factory setting) = 3 ; 3-phase electrical backup = 9			

Line	Function	Setting range or display	Setting increment	Basic setting
5813	S Output el imm heater K26 Without electrical backup = 0 ; Single phase electrical backup 3 kW = 0 ; Single phase electrical backup 6 kW (Factory setting) = 3 ; 3-phase electrical backup = 0	0,1-...99		3
5950	S Function input H1 (Connector X86, terminals B1 & M) 0: None, 1: Op'mode change zones+DHW, 2: Optg mode changeover DHW, 3: Op'mode changeover zones, 4: Op'mode changeover zone 1, 5: Op'mode changeover zone 2, 6: Op'mode changeover zone 3, 8: Error/alarm message, 9: Consumer request VK1, 10: Consumer request VK2, 11: Release swi pool source heat, 13: Release swi pool solar, 14: Operating level DHW, 15: Operating level HC1, 16: Operating level HC2, 17: Operating level HC3, 18: Room thermostat HC1, 19: Room thermostat HC2, 20: Room thermostat HC3, 21: DHW flow switch, 24: Pulse count, 26: Dewpoint monitor, 27: Flow temp setp incr hygro, 30: Swi-on command HP stage 1, 35: Status info suppl source, 36: Charg prio DHW sol fuel boil, 43: Ventilation switch 1, 44: Ventilation switch 2, 45: Ventilation switch 3, 50: Flow measurement Hz, 51: Consumer request VK1 10V, 52: Consumer request VK2 10V, 54: Pressure measurement 10V, 55: Humidity measurement 10V, 56: Room temp 10V, 59: Flow measurement 10V, 60: Temp measurement 10V, 61: Air quality measurement 10V			None
5953	S Input value 1 H1			0
5954	S Function value 1 H1			0
5955	S Input value 2 H1			10
5956	S Function value 2 H1			100
5960	S Function input H3 (Connector X86, terminals B2 & M) 0: None, 1: Op'mode change zones+DHW, 2: Optg mode changeover DHW, 3: Op'mode changeover zones, 4: Op'mode changeover zone 1, 5: Op'mode changeover zone 2, 6: Op'mode changeover zone 3, 8: Error/alarm message, 9: Consumer request VK1, 10: Consumer request VK2, 11: Release swi pool source heat, 13: Release swi pool solar, 14: Operating level DHW, 15: Operating level HC1, 16: Operating level HC2, 17: Operating level HC3, 18: Room thermostat HC1, 19: Room thermostat HC2, 20: Room thermostat HC3, 21: DHW flow switch, 24: Pulse count, 26: Dewpoint monitor, 27: Flow temp setp incr hygro, 30: Swi-on command HP stage 1, 35: Status info suppl source, 36: Charg prio DHW sol fuel boil, 43: Ventilation switch 1, 44: Ventilation switch 2, 45: Ventilation switch 3, 50: Flow measurement Hz, 51: Consumer request VK1 10V, 52: Consumer request VK2 10V, 54: Pressure measurement 10V, 55: Humidity measurement 10V, 56: Room temp 10V, 59: Flow measurement 10V, 60: Temp measurement 10V, 61: Air quality measurement 10V			None
5963	S Input value 1 H3			0
5964	S Function value 1 H3			0
5965	S Input value 2 H3			10
5966	S Function value 2 H3			100
5980	S Function input EX1 0: None, 1: Electrical utility lock E6, 2: Low-tariff E5, 4: Overload source E14, 5: Pressure switch source E26, 6: Flow switch source E15, 7: Flow switch consumers E24, 8: Manual defrost E17, 9: Common fault HP E20, 10: Fault soft starter E25, 12: Low-pressure switch E9, 13: High-pressure switch E10, 14: Overload compressor 1 E11, 15: Error/alarm message, 16: Mains supervision E21, 18: Pressure diff defrost E28, 19: Pres sw source int circ E29, 20: Flow sw source int circ E30, 21: Smart grid E61, 22: Smart grid E62, 25: Optg mode change HCs, 26: DHW push.			Electrical utility lock E6
5981	S Contact type input EX1	Normally-closed contact (NC) Normally-opened contact (NO)		NO
5982	S Function input EX2 0: None, 1: Electrical utility lock E6, 2: Low-tariff E5, 4: Overload source E14, 5: Pressure switch source E26, 6: Flow switch source E15, 7: Flow switch consumers E24, 8: Manual defrost E17, 9: Common fault HP E20, 10: Fault soft starter E25, 12: Low-pressure switch E9, 13: High-pressure switch E10, 14: Overload compressor 1 E11, 15: Error/alarm message, 16: Mains supervision E21, 18: Pressure diff defrost E28, 19: Pres sw source int circ E29, 20: Flow sw source int circ E30, 21: Smart grid E61, 22: Smart grid E62, 25: Optg mode change HCs, 26: DHW push.			Low-tariff E5
5983	S Contact type input EX2	Normally-closed contact (NC) Normally-opened contact (NO)		NC
5985	S Contact type input EX3	Normally-closed contact (NC) Normally-opened contact (NO)		NO
6098	S Readjustm collector sensor	-20... 20		0
6100	S Readjustm outdoor sensor	-3... 3 °C	0.1 °C	0 °C
6117	S Central setp compensation	1... 100°C		5 °C
6120	S Frost protection plant	On, Off		On

<i>Line</i>	<i>Function</i>	<i>Setting range or display</i>	<i>Setting increment</i>	<i>Basic setting</i>
6201	S Reset sensors	No, Yes		No
6205	S Reset to default parameters	No, Yes		No
6220	S Software version (RVS)	0... 99		--
6300	S Info 1 OEM	0... 65535		--
6301	S Info 2 OEM	0... 65535		--
LPB system				
6600	S Device address	0... 16		1
Error				
6710	U Reset Defaut relais	No, Yes		No
6711	U Reset HP	No, Yes		No
6800	S History 1	Time, Date, Error code		
6802	S History 2	Time, Date, Error code		
6804	S History 3	Time, Date, Error code		
6806	S History 4	Time, Date, Error code		
6808	S History 5	Time, Date, Error code		
6810	S History 6	Time, Date, Error code		
6812	S History 7	Time, Date, Error code		
6814	S History 8	Time, Date, Error code		
6816	S History 9	Time, Date, Error code		
6818	S History 10	Time, Date, Error code		
Maintenance / special regime				
7070	S HP interval	--, 1... 240	1 month	--
7071	S HP time since maint Reset ? (no, yes)	0... 240	1 month	0
7073	S Cur starts compr1/hrs run (since the 6 last weeks) Reset ? (no, yes)	0... 12		0
7141	U Emergency operation	Off, On		Off
	Off: Heat pump functions normally (with boosters if necessary). On: Heat pump uses the electric boost system or the boiler connection. Use the "On" position only in Assist mode or Test mode: may result in high power bills.			
7142	S Emergency operating function type	Manual, Automatic		Manual
	Manual: Emergency mode is not active when a fault occurs (Emergency mode = OFF). Automatic: Emergency mode is active when a fault occurs (Emergency mode = ON). In "Automatic" position, the energy cost can be onerous if the error is not detected and eliminated.			
7150	I Simulation outdoor temp	-50... 50 °C	0.5	--

Line	Function	Setting range or display	Setting increment	Basic setting
Inputs / outputs test				
7700	I Relay test			No test
<p>This consists of instructing the regulator's relays one by one and checking their outputs. This enables you to check that the relays are working and that the cabling is correct. Check that each appliance in the installation is operating correctly.</p> <p>0: No test, 1: Everything is on STOP, 2: Relay output QX1 : heat pump CC1 (if 1 circuit) or heat pump CC2 (if 2 circuits), 3: Relay output QX2 : Electrical back-up (1st stage) or Boiler connection distribution valve, 4: Relay output QX3 : Electrical back-up (2nd stage) or Boiler connection contact, 5: Relay output QX4 : DHW distribution valve, 6: Relay output QX5 : DHW Electrical back-up, 7: Relay output QX6 , 8: Relay output QX31 : Heat circ mix valve open Y1 (or control pilot-wire), 9: Relay output QX32 : Heat circ mix valve close Y2, 10: Relay output QX33 : heat pump CC1 if 2 circuits (mixed circuit, the less hot), 11: Relay output QX34, 12: Relay output QX35 : Swimming pool distribution valve, 13: Relay output QX21 module 1, 14: Relay output QX22 module 1, 15: Relay output QX23 module 1, 16: Relay output QX21 module 2, 17: Relay output QX22 module 2, 18: Relay output QX23 module 2, 19: Not used, 20: Not used, 21: Not used.</p> <p>The display shows the "Key" symbol. Pressing the Info button displays "Error 368". Warning: The component being tested is receiving electrical power throughout the test.</p>				
7710	I Output UX1 test	0... 100%	1	--
7716	I Output UX2 test	0... 100%	1	--
7722	I Digital output DO2	Off, On		Off
7723	I Heat pump D3	Off, On		Off
7724	I Outputs test UX3 ("Inverter" command)	0... 100 %		--
7725	I Voltage value U4 (Ux3)	0... 10 v		--
7804	I Sensor temperature BX1 (HP flow temperature)	-28... 350 °C		--
7805	I Sensor temperature BX2 (HP return temperature)	-28... 350 °C		--
7806	I Sensor temperature BX3 (DHW temperature)	-28... 350 °C		--
7807	I Sensor temperature BX4 (Outdoor temperature)	-28... 350 °C		--
7858	I Input signal H3	None, Closed (ooo), Open (---), Pulse, Frequency Hz, Voltage V		None
7911	I Input EX1 (Power shedding, EJP)	0, 230 V		--
7912	I Input EX2 (Tariffs day/night)	0, 230 V		--
7913	I Input EX3 (External fault)	0, 230 V		--
State				
8000	I State heating circuit 1			--
8001	I State heating circuit 2			--
8003	I State DHW			--
8004	I State cooling circuit 1			--
8006	I State heat pump			--
8007	I State solar			--
8010	I State buffer			--
8011	I State swimming pool			--
8022	I State supplementary source			--
8025	I State cooling circuit 2			--

<i>Line</i>	<i>Function</i>	<i>Setting range or display</i>	<i>Setting increment</i>	<i>Basic setting</i>
Generator diagnosis				
8400	I Compressor 1	Off, On		Off
8402	I Electrical resistance flow 1	Off, On		Off
8403	I Electrical resistance flow 2	Off, On		Off
8406	I Condenser pump	Off, On		Off
8407	S Speed condenser pump	0...100%		--
8410	U Return temp HP	0... 140 °C		--
	Setpoint (flow) HP			--
8412	U Flow temp HP	0... 140 °C		--
	Setpoint (flow) HP			--
8413	U Compressor modulation	0... 100%		--
8414	I Modulation electric flow	0... 100%		--
8425	S Temp diff condensor	-50... 140 °C		--
8450	S Hours run compressor 1	00:00		--
8454	S Locking time Heat Pump Reset ? (no, yes)	0... 2730 h		--
8455	S Counter number of locks HP Reset ? (no, yes)	0... 65535		--
8456	S Hours run electrical flow Reset ? (no, yes)	0... 2730 h		--
8457	S Start counter electrical flow Reset ? (no, yes)	0... 65535		--
8458	I State smart grid	Draw disabled, Draw free, Draw wish, Draw forced		Draw free
8460	I Heat pump throughput	0... 65535 l/min		--
Diagnostics consumers				
8700	U Outdoor temperature	-50... 50 °C		--
8701	U Outdoor temp min Reset ? (no, yes)	-50... 50 °C		50 °C
8702	U Outdoor temp max Reset ? (no, yes)	-50... 50 °C		-50 °C
8703	I Outdoor temp attenuated Reset ? (no, yes)	-50... 50 °C		--
	This is the average of the outdoor temperature over a 24-hour period. This value is used for automatic Summer / Winter switchover (line 730).			
8704	I Outdoor temp composite	-50... 50 °C		--
	The mixed outdoor temperature is a combination of the current outdoor temperature and the average outdoor temperature calculated by the regulator. This value is used for calculating the initial temperature.			
8730	I Heating circuit pump, circuit 1	Off, On		Off
8731	I Mixer valve HC1 open	Off, On		Off
8732	I Mixer valve HC1 closed	Off, On		Off
8740	U Room temperature 1	0... 50 °C		--
	Room setting 1			20 °C
8743	U Flow temperature 1	0... 140 °C		--
	Flow temperature setpoint 1			--
8749	I Room thermostat 1	No demand, Demand		No demand

Line	Function	Setting range or display	Setting increment	Basic setting
8756	U Cooling flow temperature 1	0... 140 °C		--
	Cooling flow temperature setpoint 1			--
8820	I DHW pump	Off, On		Off
8821	I El imm heater DHW	Off, On		Off
8830	U DHW (domestic hot water) temperature	0... 140 °C		--
	DHW temperature setpoint			50 °C
8832	I DHW temp 2	0... 140 °C		--
8840	S Hours run DHW pump	0... 2730 h		--
8841	S Start counter DHW pump	0... 199999		--
8842	S Hours run electric DHW	0... 2730 h		--
8843	S Start counter electric DHW	0... 65535		--
8950	I Common flow temperature	0... 140 °C		--
	Common flow temperature setpoint			--
8957	I Common flow setpoint, Refrigerant	0... 140 °C		--
9005	I Water pressure 1	-100... 500 bar		--
9006	I Water pressure 2	-100... 500 bar		--
9009	I Water pressure 3	-100... 500 bar		--
9010	I Measurement room temp 1	0...50 °C		--
9011	I Measurement room temp 2	0... 50 °C		--
9031	I Relay output QX1	Off, On		On
9032	I Relay output QX2	Off, On		On
9033	I Relay output QX3	Off, On		On
9034	I Relay output QX4	Off, On		Off
9035	I Relay output QX5	Off, On		Off

► Information display

Various data can be displayed by pressing the  button.

Depending on the type of unit, configuration and operating state, some of the info lines listed below may not appear.

- Possible error messages from the error code list (see table, [page 74](#)).
- Possible service messages from the maintenance code list.
- Possible special mode messages.
- Various data (see below).

Designation	Line
Floor drying current setpoint.	-
Current drying day.	-
Terminated drying days.	-
State heat pump.	8006
State supplementary source.	8022
State DHW.	8003
State swimming pool.	8011
State heating circuit 1.	8000
State heating circuit 2.	8001
State cooling circuit 1.	8004
Outdoor temperature.	8700
Room temperature 1.	8740
Room setpoint 1.	
Flow temperature 1.	8743
Flow temperature setpoint1.	
Room temperature 2.	8770
Room setpoint 2.	
Flow temperature 2.	8773
Flow temperature setpoint 2.	
DHW (domestic hot water) temperature.	8830
Heat pump return temperature.	8410
Setpoint (return) HP.	
Heat pump flow temperature.	8412
Setpoint (flow) HP.	
Swimming pool temperature.	8900
Swimming pool temperature setpoint.	
Minimum remaining stop time for compressor 1.	-
Minimum remaining running time for compressor 1.	-



A series of horizontal dotted lines spanning the width of the page, providing a guide for handwriting practice.

Basic Hydraulic Layout

■ Configuration: 1 heating circuit

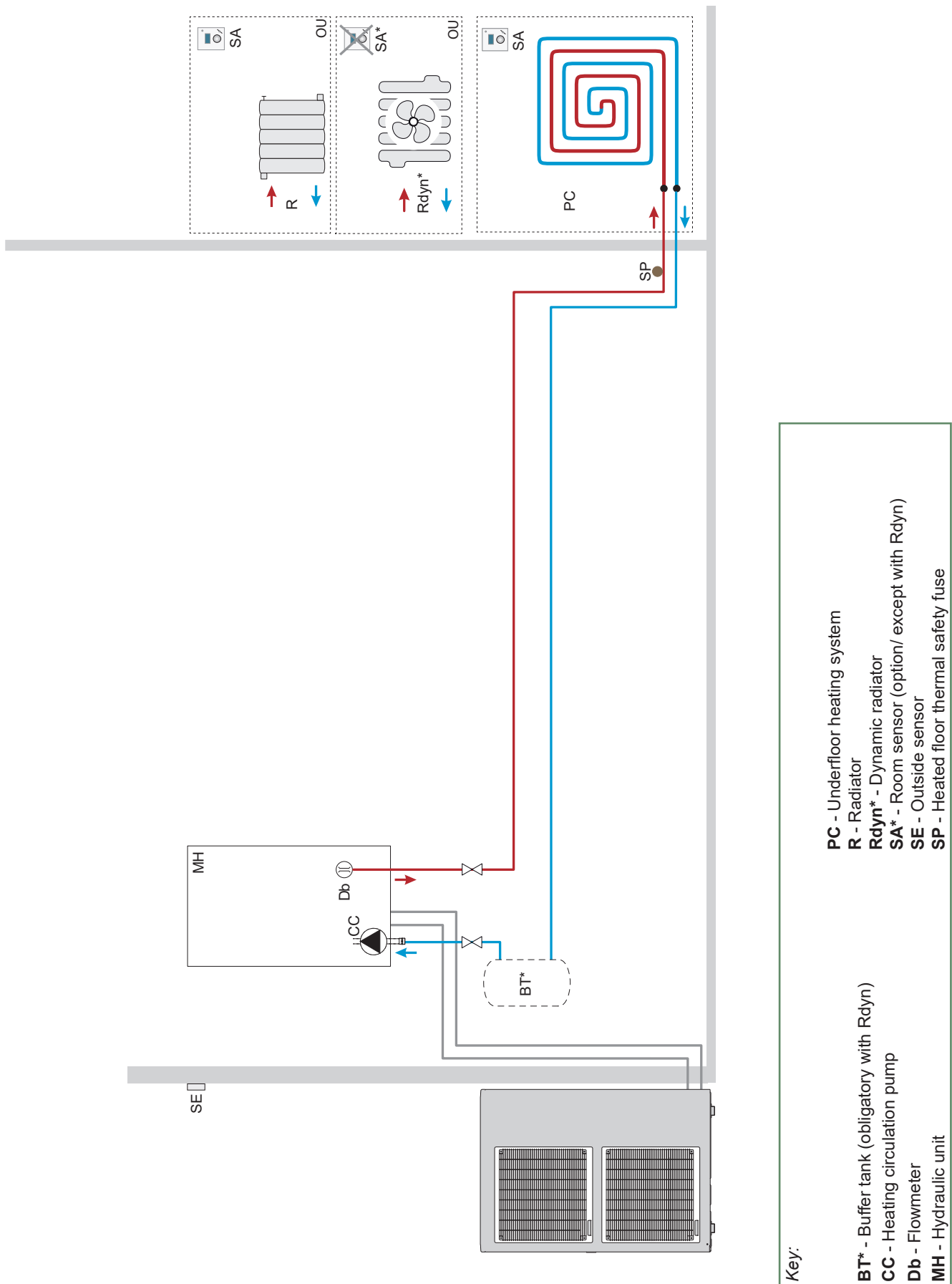

Key:

- PC** - Underfloor heating system
- R** - Radiator
- Rdyn*** - Dynamic radiator
- SA*** - Room sensor (option/ except with Rdyn)
- SE** - Outside sensor
- SP** - Heated floor thermal safety fuse
- BT*** - Buffer tank (obligatory with Rdyn)
- CC** - Heating circulation pump
- Db** - Flowmeter
- MH** - Hydraulic unit

■ Configuration: 1 heating circuit and mixed hot water tank

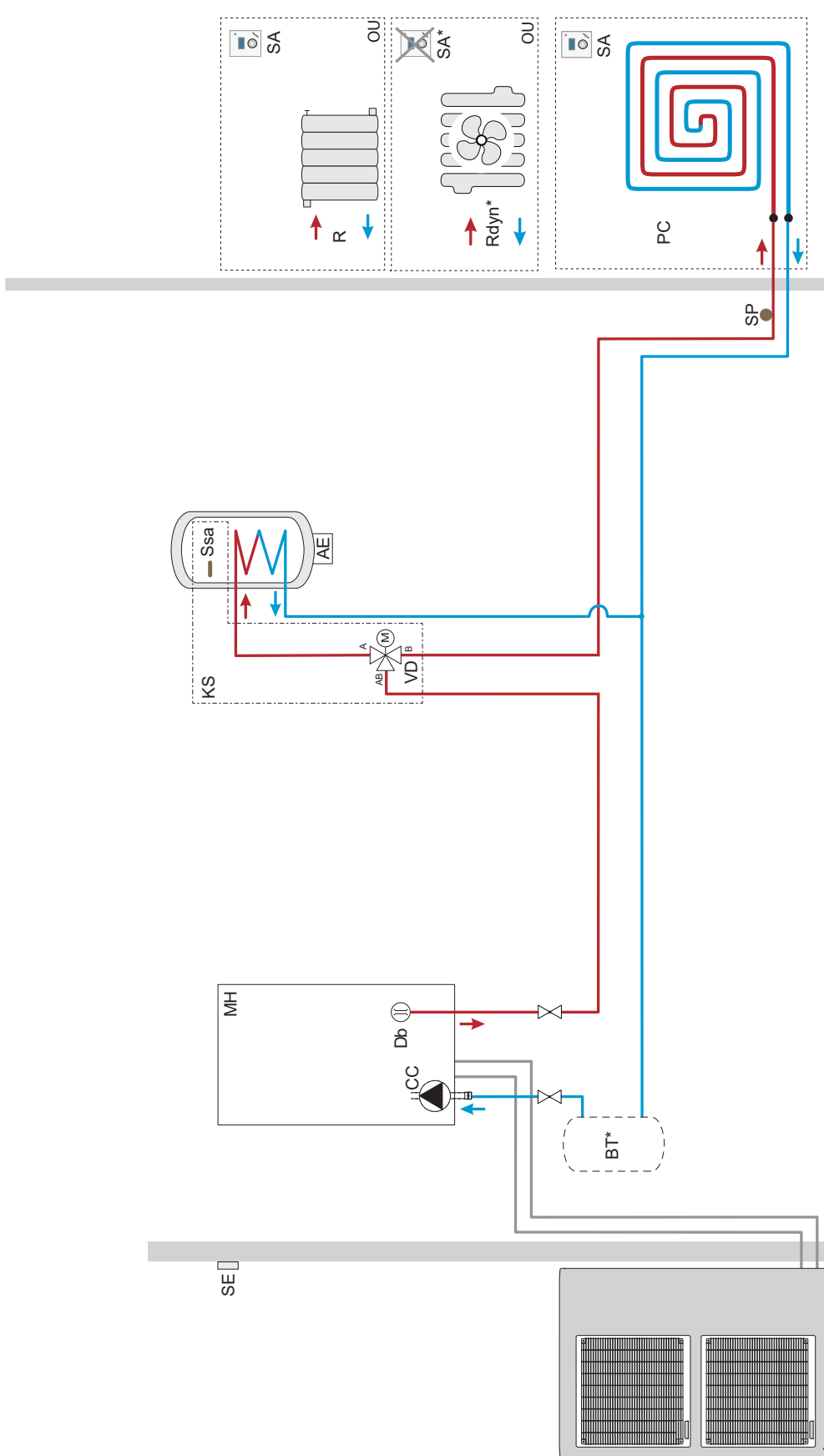

Key:	
AE	- Electrical backup
BT*	- Buffer tank (obligatory with Rdyn, if HP>11kW)
CC	- Heating circulation pump
Db	- Flowmeter
KS	- DHW kit
MH	- Hydraulic unit
PC	- Underfloor heating system
R	- Radiator
Rdyn*	- Dynamic radiator
SA*	- Room sensor (option/ except with Rdyn)
Ssa	- Hot water sensor
SE	- Outside sensor
SP	- Heated floor thermal safety fuse
VD	- Distribution valve

Electrical Cabling Plans

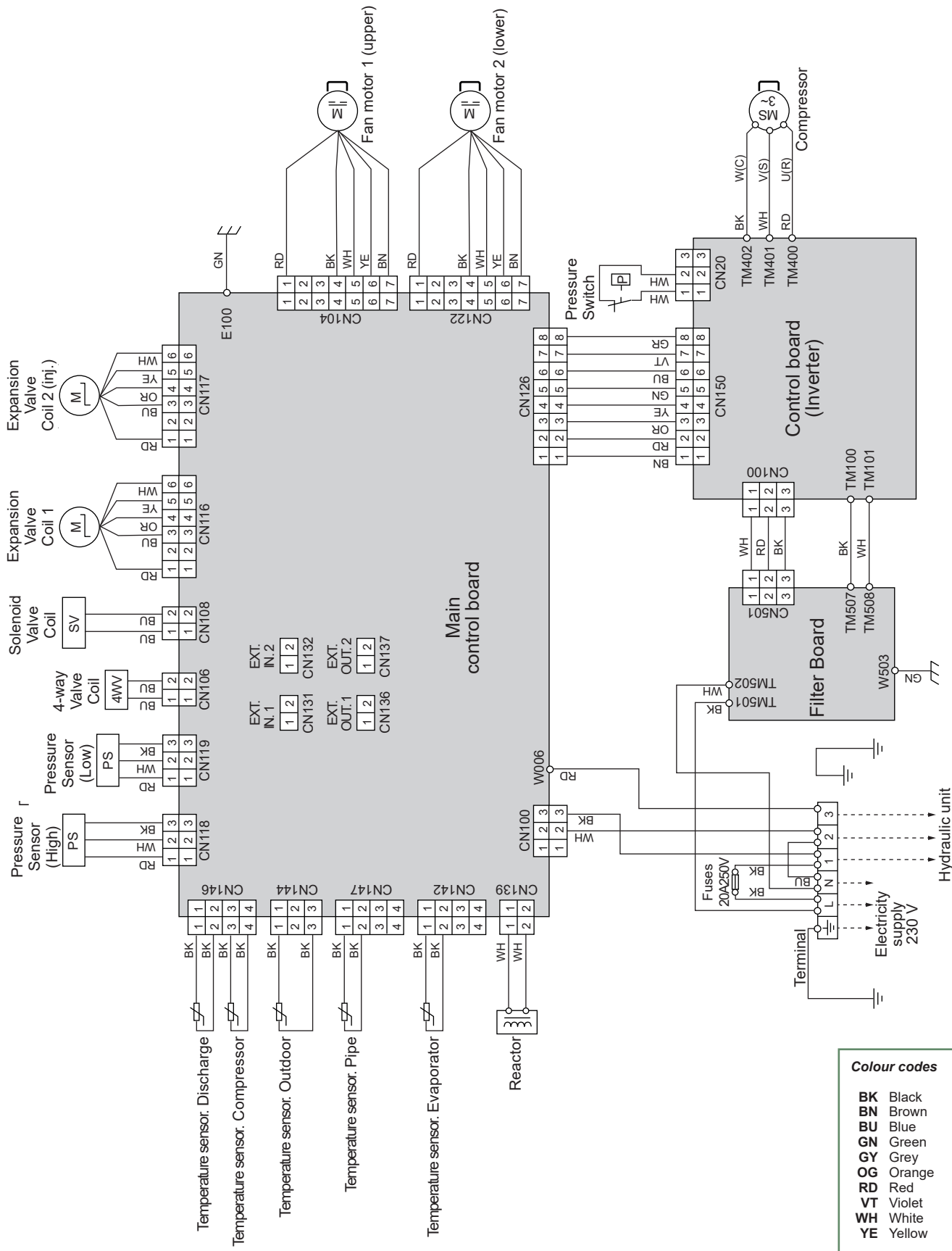

fig. 41 - Outdoor unit electrical cabling single phase

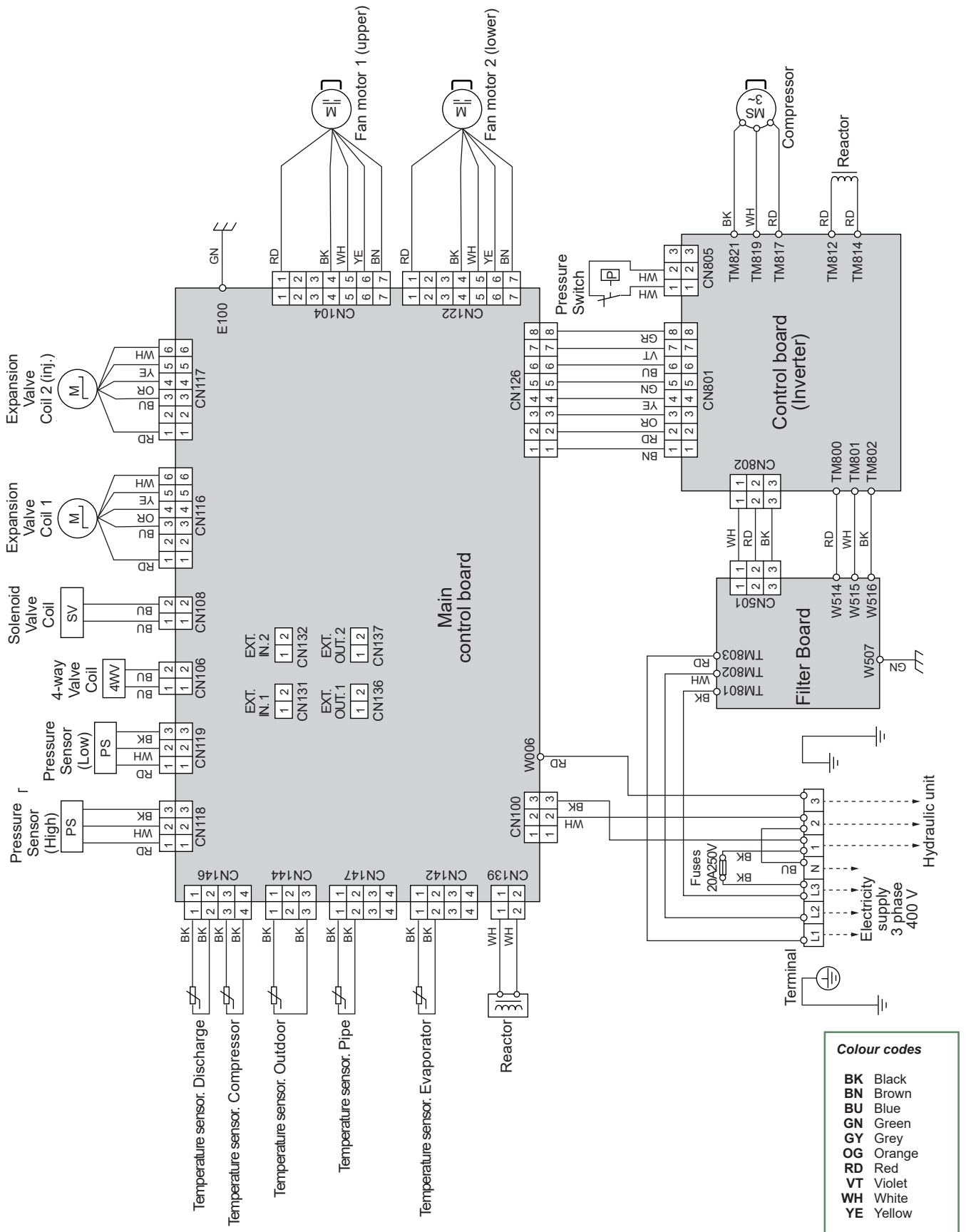

fig. 42 - Outdoor unit electrical cabling 3-phase

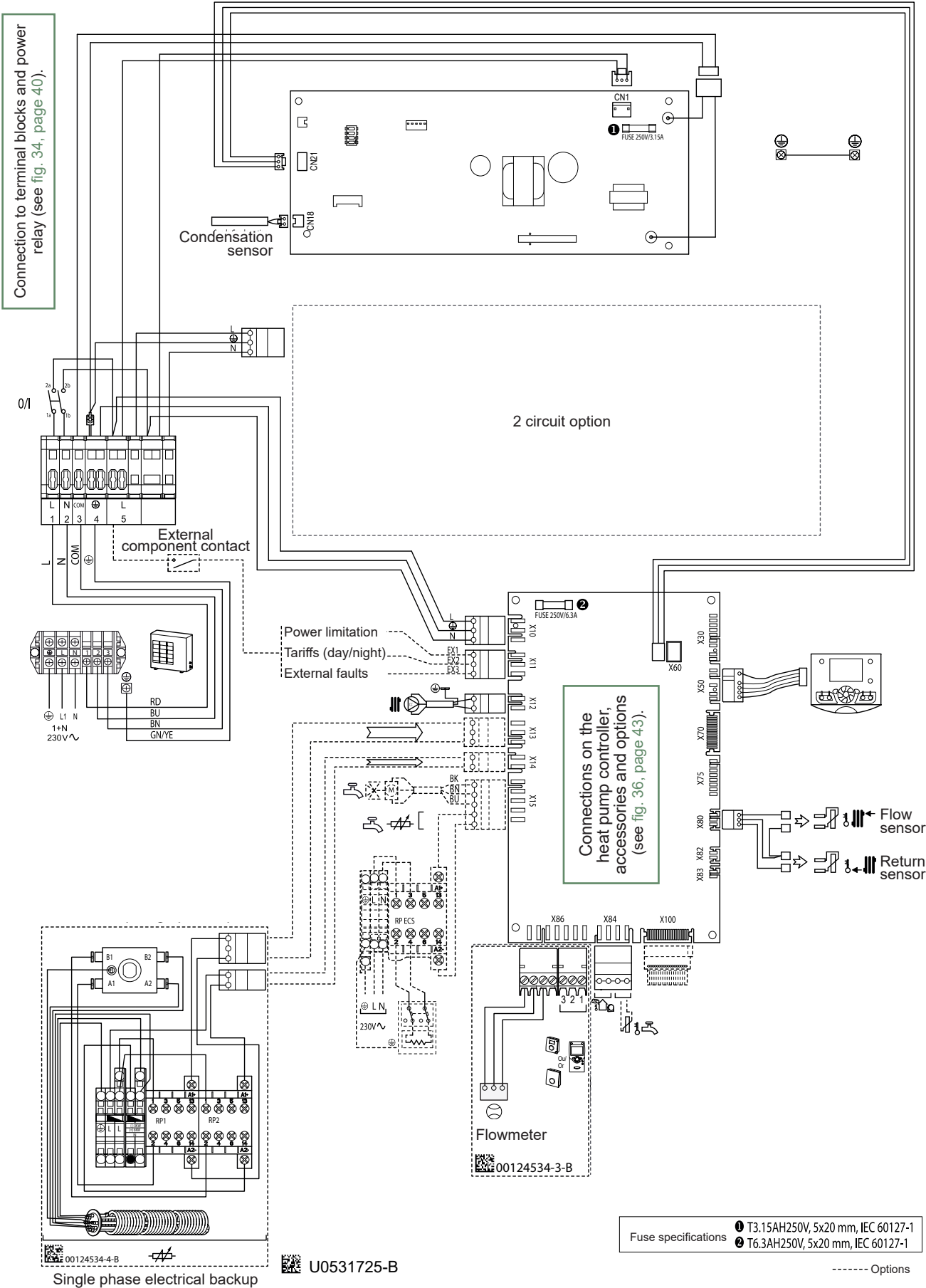

fig. 43 - Electrical cabling of single phase hydraulic unit (excluding connections made by installer)

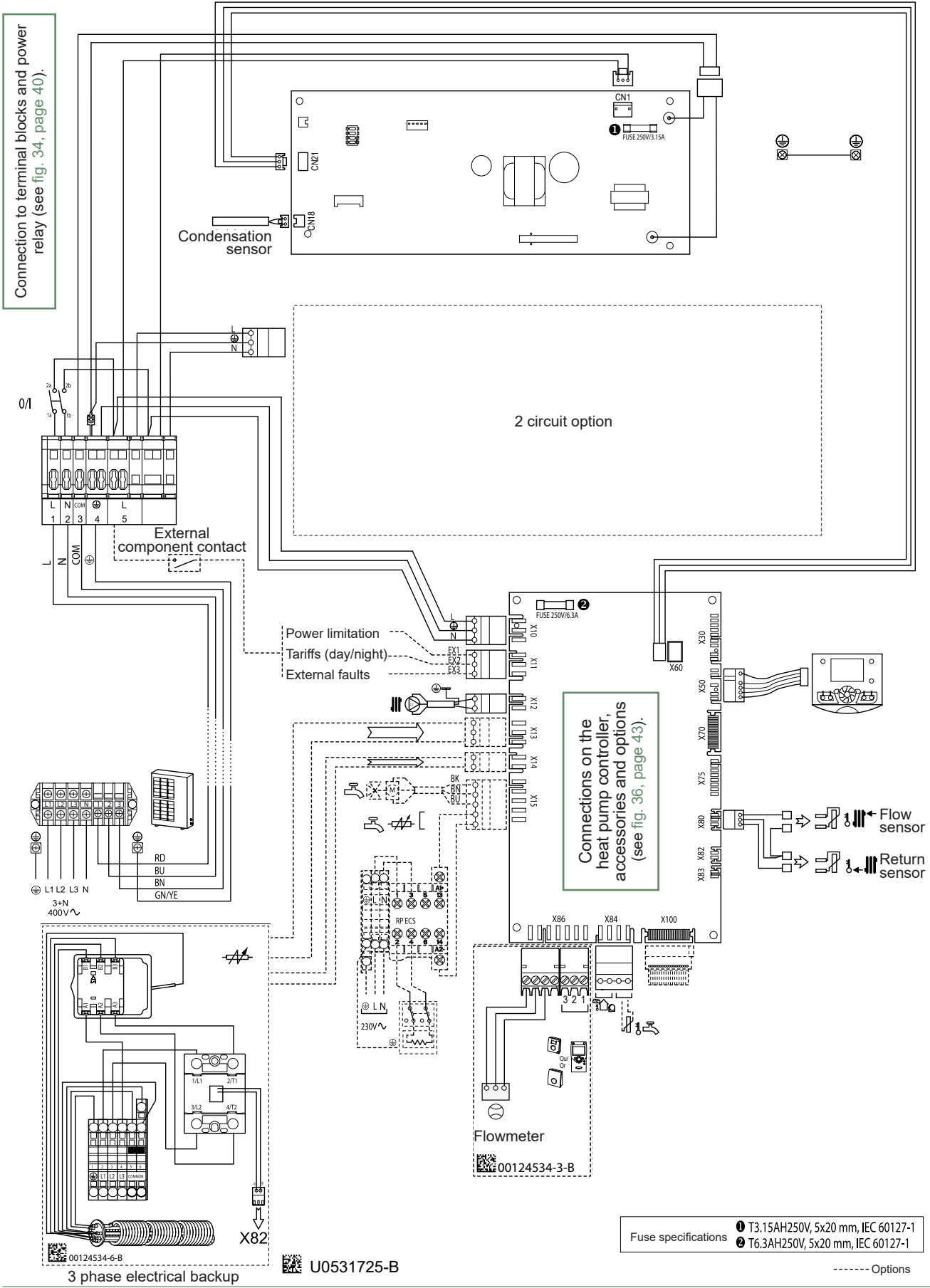

fig. 44 - Electrical cabling of 3-phase hydraulic unit (excluding connections made by installer)

Fault Diagnosis

Depending on whether the fault comes from the outdoor unit or the hydraulic unit, the fault may be indicated by the digital display or the LED on the interface cards.

► Faults in the Hydraulic Unit

Faults or breakdowns on the hydraulic unit are indicated by the display on the user interface.

The display shows the  symbol.

Press the  key for more details on the origin of the fault.

When the error has been resolved, the faults are re-initialised at zero automatically.

Hydraulic unit: Fault visible on the digital display.

Error	Designation	Probable causes	Proposed actions
10	Outside sensor	Short-circuit. Unplugged or disconnected sensor. Faulty sensor. Other fault.	Check the sensor's wiring. Replace the sensor.
32	Flow sensor 2		
33	Flow sensor HP		
44	Return sensor HP		
50	DHW sensor 1		
60	Room sensor 1		
65	Room sensor 2		
83	BSB, short circuit	Wiring problem (between the sensor or remote control, display and controller).	Check the wiring.
127	Legionella temp	Anti-legionella temp setpoint not reached.	Check the wiring of the DHW backup / boiler connection.
212	Internal comm failure	Unplugged or disconnected sensor.	Check the sensor's wiring.
356	Flowmeter	Insufficient flow.	Check the opening of the valves of the installation. Check the flowmeter's wiring. Replace the flowmeter.
369	External	External safety triggered EX3.	-
370	Thermodynamic source	See details page 74 .	-
441	BX31 no function	Short-circuit. Unplugged or disconnected sensor. Faulty sensor. Other fault.	Check the sensor's wiring. Replace the sensor.
442	BX24 no function		
443	BX33 no function		
444	BX34 no function		
516	Heat pump missing	Loss of connection between controller and HP.	Check the wiring between X60 and the interface board.



Before any maintenance operation, ensure that the general power supply is switched off.
Frost protection is not available when the heat pump is not powered up.



Hydraulic unit: Flashing of the LED visible on the interface card.

Outdoor unit Error number	LED display		Error contents
	LED 2 (green)	LED 1 (red)	
11	1 Flash	1 Flash	Communication error between Hydraulic unit and Outdoor unit.
23	2 Flashes	3 Flashes	Connection forbidden (series error).
31	3 Flashes	1 Flash	Indoor unit power supply abnormal.
32	3 Flashes	2 Flashes	Serial communication error between Controller /Interface PCBs.
41	4 Flashes	1 Flash	Heat pump capacity signal error (Open or short).
42	4 Flashes	2 Flashes	Hydraulic unit heat-exchange thermistor Error.
61	6 Flashes	1 Flash	Outdoor unit power supply abnormal.
62	6 Flashes	2 Flashes	Outdoor unit main PCB error.
63	6 Flashes	3 Flashes	Inverter error.
64	6 Flashes	4 Flashes	Active filter error.
65	6 Flashes	5 Flashes	Outdoor unit IPM error.
67	6 Flashes	7 Flashes	Outdoor unit power short interruption error (protective operation).
68	6 Flashes	8 Flashes	Outdoor unit magnetic relay error.
71	7 Flashes	1 Flash	Discharge thermistor error.
72	7 Flashes	2 Flashes	Compressor thermistor error.
73	7 Flashes	3 Flashes	Heat-exchange thermistor (outlet / intermediate) error.
74	7 Flashes	4 Flashes	Outdoor thermistor error.
77	7 Flashes	7 Flashes	Outdoor unit heat sink temp. thermistor error.
78	7 Flashes	8 Flashes	Expansion valve thermistor error.
84	8 Flashes	4 Flashes	Current sensor error.
86	8 Flashes	6 Flashes	Pressure sensor error / Pressure switch error.
94	9 Flashes	4 Flashes	Current trip.
95	9 Flashes	5 Flashes	Detection of compressor position error / Compressor start up error.
97	9 Flashes	7 Flashes	Outdoor unit fan1 motor error.
98	9 Flashes	8 Flashes	Outdoor unit fan2 motor error.
A1	10 Flashes	1 Flash	Discharge temperature protection.
A3	10 Flashes	3 Flashes	Compressor temperature protection.
A4	10 Flashes	4 Flashes	Outdoor unit pressure error.
A5	10 Flashes	5 Flashes	Low pressure abnormal.
A9	10 Flashes	9 Flashes	Current overload error.
-	Continuous flashing (1 sec On / 1 sec Off)		Pump down operation.
-	Continuous lighting	Off	Defrosting.

► Faults displayed on the single phase outdoor unit

To access the electronic board, you must remove the front (right-hand) facing from the outdoor unit.

Faults are coded by LED flashes.

When an error occurs:

The LED "**ERROR**" (2) blinks.

Press once on the switch "**ENTER**" (SW109).

The "**ERROR**" (2) LED blinks several times depending on the error's type (see below).

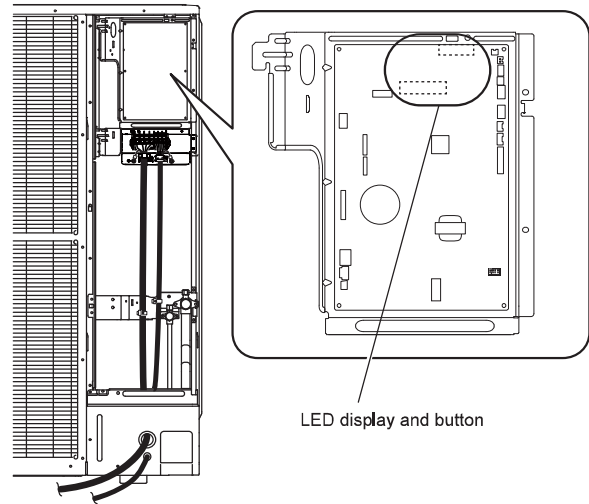

LED DISPLAY

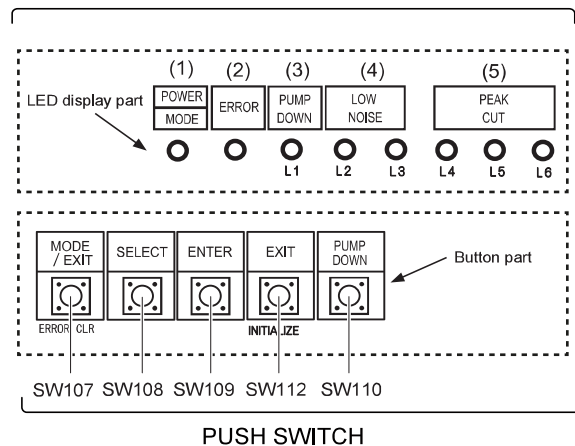

PUSH SWITCH

fig. 45 - Location of switches and LED on single phase outdoor unit

LED display	Error contents
1 Flash	Serial forward transfer error.
2 Flashes	Discharge thermistor error.
3 Flashes	Pressure switch error.
4 Flashes	Heat-exchange thermistor (outlet) error.
6 Flashes	Expansion valve thermistor error.
7 Flashes	Outdoor temperature thermistor error.
8 Flashes	Compressor thermistor error.
9 Flashes	Transistor PCB error.
11 Flashes	Discharge temperature error (permanent stoppage).
12 Flashes	Compressor temperature error (permanent stoppage).
13 Flashes	Over current error (permanent stoppage).
15 Flashes	Compressor start up error (permanent stoppage).
16 Flashes	Fan motor 1 error (permanent stoppage).
17 Flashes	Fan motor 2 error (permanent stoppage).
18 Flashes	Inverter error.
20 Flashes	Low pressure error.
23 Flashes	Discharge pressure sensor error.
24 Flashes	Suction pressure sensor error.



Before any maintenance operation, ensure that the general power supply is switched off.

Frost protection is not available when the heat pump is not powered up.



► Faults displayed on the 3-phase outdoor unit

To access the electronic board, you must remove the front (right-hand) facing from the outdoor unit.

Faults are coded by LED flashes.

When an error occurs:

The LED "ERROR" (2) blinks.

Press once on the switch "ENTER" (SW109).

The "ERROR" (2) LED blinks several times depending on the error's type (see below).

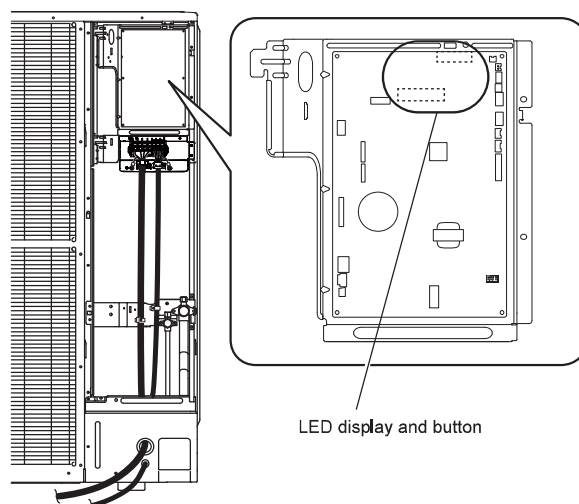

LED DISPLAY

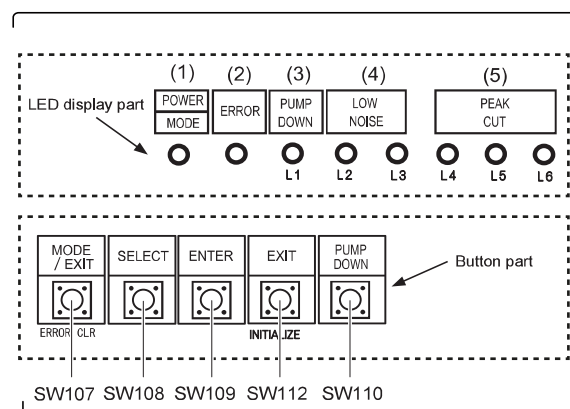

PUSH SWITCH

fig. 46 - Location of switches and LED on 3-phase outdoor unit

LED display	Error contents
1 Flash	Serial forward transfer error.
2 Flashes	Discharge thermistor error.
3 Flashes	Pressure switch error.
4 Flashes	Heat-exchange thermistor (outlet) error.
6 Flashes	Expansion valve thermistor error.
7 Flashes	Outdoor temperature thermistor error.
8 Flashes	Compressor thermistor error.
9 Flashes	Transistor PCB error.
11 Flashes	Discharge temperature error (permanent stoppage).
12 Flashes	Compressor temperature error (permanent stoppage).
13 Flashes	Over current error (permanent stoppage).
14 Flashes	Detection of compressor position error (permanent stoppage).
15 Flashes	Compressor start up error (permanent stoppage).
16 Flashes	Fan motor 1 error (permanent stoppage).
17 Flashes	Fan motor 2 error (permanent stoppage).
18 Flashes	Inverter error.
20 Flashes	Low pressure abnormal.
23 Flashes	Discharge pressure sensor error.
24 Flashes	Suction pressure sensor error.

Maintenance of the installation



Before any maintenance operation, ensure that the general power supply is switched off.



► Hydraulic checks



If frequent refills are required it is absolutely essential that you check for any leaks. If refilling and a pressure reset are necessary, check what type of fluid was used initially.

Recommended filling pressure: between 1 and 2 bar (the exact filling pressure is determined by the water pressure in the installation).

Every year,

- Check the expansion circuit pressure (pre-inflation of 1 bar) and the correct operation of the safety valve.

If the installation is fitted with a hot water tank:

- Check the safety valve on the cold water supply inlet. Make it operate as advised by the manufacturer.
- Check the back flow preventer.

► Checking the outdoor unit

- Remove any dust from the exchanger, if necessary, while making sure not to damage the blades.
- Straighten the blades using a comb.
- Check that there is nothing blocking the air flow.
- Check the fan.
- Verify that condensate drain is not obstructed.

• Checking the refrigeration circuit

If the amount of refrigerant in the system exceeds 2kg (models > 10kW), the refrigeration circuit must be checked annually by an approved engineer (they must have a certificate of competence for the handling of refrigerants).

- Check there are no leaks (connections, valves...).

► Electrical checks

- Check the connections and re-tighten if necessary.
- Check the state of the cables and plates.

Other maintenance

► Emptying the hydraulic unit

- Remove the front panel of the hydraulic unit.
- Open the drain plug,
- Check that the hydraulic unit's bleeder valve opens automatically,
- Open the installation's bleeder valve(s).

► Distribution valve

If the installation is fitted with a hot water tank.

Ensure the distribution valve is fitted in the correct direction.

Channel **AB**: Outlet to the hydraulic unit.

Channel **A** open: Return from DHW tank.

Channel **B** open: Return from the heating circuit.

Instructions for the end user



Explain to the user how his installation operates, in particular the functions of the room sensor and the programmes accessible to them via the user interface.

Emphasise that a heated floor has significant inertia and that therefore any adjustments must be made gradually.

Also explain to the end user how to check the filling of the heating circuit.



End-of-life of the appliance

The appliances must be dismantled and recycled by a specialised service. The appliances must not, under any circumstances, be thrown out with household waste, bulky waste or at a tip.

At the end of its service life, please contact your installer or local representative to proceed with its dismantling and recycling.



This unit is identified by this symbol. It means that all electrical and electronic products must not be included in household waste.

A specific recycling system for this type of product has been set up in European Union countries (*), Norway, Iceland and Liechtenstein.

Do not try to dismantle this product yourself. It may have damaging effects on your health or on the environment.

Reprocessing of the refrigerant, lubricant and other parts may be performed by a qualified installer in compliance with the local and national legislation in force.

This unit must be recycled by a specialised service and in no case may it be thrown away with household waste, rubble or in a landfill.

Please contact your installer or local representative for more .

* Depending on the national regulations of each member state.

✓ Quick-start procedure

Before switching on the hydraulic unit:

- Check the electric wiring.
- Check the refrigeration circuit and make sure the it has been gassed.
- Check the hydraulic circuit's pressure (1 to 2 bar), check that the heat pump has been bled, along with the rest of the installation.
- Make sure that ALL DIP SW on the interface board are OFF before starting up.

► Start-up check-list

▼ Before starting-up

	OK	Not compliant
Sight checks Outdoor unit (see chapter "Installation of the outdoor unit", page 18).		
Location and fittings, condensate evacuation.		
Comply with distances from obstacles.		
Hydraulic checks Hydraulic unit (see chapter "Installation of the hydraulic unit", page 20).		
Connection of pipes, valves and pumps (heating circuit, DHW).		
Installation water volume (expansion vessel of adequate capacity?).		
No leaks.		
Main system pressure and degassing.		
Refrigeration connections and checks (see chapters "Refrigeration connections", page 22).		
Check the refrigeration circuits (sealing, no dust or humidity).		
Connections between units (pipe length, flare tightening torque...).		
Installation of HP pressure gauges on the gas line (large tube).		
Pump down mandatory.		
Nitrogen leak test (~ 10 bar).		
Opening of refrigeration valves to outdoor unit.		
Filling hydraulic unit and pipes with refrigerant.		
Electrical checks Outdoor unit (see chapter "Electrical connections", page 34).		
Main power supply (230 V or 400 V).		
Protection by rated circuit breaker.		
Cable dimensions.		
Earth connection.		
Hydraulic unit (see chapter "Electrical connections on the hydraulic unit side", page 38).		
Connection to outdoor unit (L, N, Earth or 3 L, N, Earth).		
Sensors connection (positioning and connections).		
Distribution valve connections (boiler and DHW) and circulation pump.		
Power supply and protection of electric backup (option).		

▼ Starting-up

	OK	Not compliant
Quick Start Procedure (see chapter "⚙️ Commissioning", page 44 and § "🔧 Controller Menu", page 50).		
Close the installation's main circuit breaker (outdoor unit power supply) <u>2 hours before testing</u> => Preheating of the compressor.		
Press the On/Off Switch => Initialisation takes several seconds.		
Operation of the heating circulation pump.		
Outdoor unit starts after 4 mins.		
Configure Time, Date and Heating circuit, DHW period programs if different from the default values.		
Configure the hydraulic circuit.		
Adjust the heating gradient.		
Adjust the max flow setpoint.		
Outdoor unit checks		
Operation of fan(s), compressor.		
Current measurement.		
After several minutes measure the difference in air temperature.		
Check condensation and evaporation pressure/temperature.		
Hydraulic unit checks		
After 15 mins of operation.		
Primary water temp. difference.		
Operation of heating, boiler backup, etc.		
Control (see chapter "🔧 Controller Menu", page 50)		
Settings, maintenance, checks.		
Program the heating periods.		
Adjust the setpoints for the heating circuits if different from the default values.		
Setpoint display.		
Explanations of use		



The heat pump is ready for operation !

► Settings sheet

Setting	Description	Set to.	Menus
Preliminary settings			
20	language		<i>operator section</i>
1	hour / minutes		<i>time & date</i>
2	day / month		<i>time & date</i>
3	year		<i>time & date</i>
5700	installation config.		<i>configuration</i>
Heating circuit No. 1 if 2 circuits = the least warm one (e.g.: floor)			
710	comfort setpoint		<i>HC1 adjust.</i>
712	reduced setpoint		<i>HC1 adjust.</i>
720	heating curve slope		<i>HC1 adjust.</i>
741	flow temp setpoint max		<i>HC1 adjust.</i>
750	room influence		<i>HC1 adjust.</i>
790 / 791	optimis. at switch-on / off		<i>HC1 adjust.</i>
834	servomotor travel time		<i>HC1 adjust.</i>
850 / 851	floor drying		<i>HC1 adjust.</i>
Heating circuit No. 2 (with 2nd circuit option) = the warmest one (e.g.: radiators)			
1010	comfort setpoint		<i>HC2 adjust.</i>
1012	reduced setpoint		<i>HC2 adjust.</i>
1020	heating curve slope		<i>HC2 adjust.</i>
1041	flow temp setpoint max		<i>HC2 adjust.</i>
1050	room influence		<i>HC2 adjust.</i>
1090 / 1091	optimis. at switch-on / off		<i>HC2 adjust.</i>
1134	servomotor travel time		<i>HC2 adjust.</i>
1150 / 1151	floor drying		<i>HC2 adjust.</i>
Domestic Hot Water (with DHW kit)			
1610	nominal DHW temp. setpoint		<i>DHW</i>
1612	reduced DWH temp. setpoint		<i>DHW</i>
1620	DHW release		<i>DHW</i>
1640 to 1642	legionella cycle		<i>DHW</i>
5024	DHW switch-on differ.		<i>DHW tank</i>
5030	charging time limitation		<i>DHW tank</i>
5061	heater release		<i>DHW tank</i>

Setting	Description	Set to.	Menus
Boiler backup			
3700	OT.switch-on authoris.		<i>addit. gen.</i>
3705	switch-off delay		<i>addit. gen.</i>
Miscellaneous			
6420	input H33 function	1	<i>configuration</i>
6100	OT sensor correction		<i>configuration</i>
6120	frost protection on/off		<i>configuration</i>
6205	reset settings		<i>configuration</i>
6220	software version		<i>configuration</i>
6711	reset heat pump		<i>error</i>
Cooling			
5711	cooling unit	2 pipes	<i>configuration</i>
Faults (if a fault occurs, press "Info" key)			
No. 10	outdoor sensor		
No. 33	flow temp. sensor		
No. 44	return temp. sensor		
No. 50	DHW temp. sensor		
No. 60	room sensor 1		
No. 65	room sensor 2		
No. 105	maintenance message		
No. 121	HC1 flow T not reached		
No. 122	HC2 flow T not reached		
No. 127	leg. prot. T not reached		
No. 369	external fault (EX3)		
No. 370	outdoor unit connect error		
6711	reset heat pump		<i>error</i>
Heat pump			
2844	switch-off temp max		<i>heat pump</i>
2884	OT auth. to start elec. aux.		<i>heat pump</i>
2920	Pk day clear (EX1) rel / lock		<i>heat pump</i>
Swimming pool (with "swimming pool" kit)			
2056	generator setpoint		<i>Sw pool</i>
Outdoor unit faults (see page 75)			

► Commissioning technical datasheet

Site				Installer					
Outdoor unit		Serial N°.			Hydraulic unit		Serial N°.		
		Model					Model		
Refrigerant type				Refrigerant load				kg	
Checks				Operating voltage & current on outdoor unit					
Compliance with positioning distances				L/N or L1/N		V			
Condensate evacuation correct				L2/N		V			
Electric connections / connections tightness				L3/N		V			
No GAS leaks (unit ID N°.:)				L/T or L1/T		V			
Installation refrigeration connection correct (length m)				L2/T		V			
Taken in operation when HOT				L3/T		V			
Compressor discharge temperature				N/E		V			
Liquid line temp.				Icomp		A			
Condensation temperature		HP =	bar	°C		Under-cooling		°C	
Tank water output temperature				°C		ΔCondensation Temp.		°C	
Tank water input temperature				°C		ΔSecondary Temp.		°C	
Evaporation temperature		LP =	bar	°C					
Suction Temp.				°C		Overheating		°C	
Battery air input temperature				°C		ΔEvaporation Temp.		°C	
Battery air output temperature				°C		ΔBattery Temp.		°C	
Hydraulic network on hydraulic unit									
Secondary system		Underfloor heating system				Circulation pump brand		Type	
		LT Radiators							
		Fan coils							
Domestic hot water; tank type									
Estimated water volume of secondary system				L					
Options & accessories									
Power supply for electric backup						Room sensor T75			
Correct location of room sensor						Wireless room sensor T78			
2 circuit kit									
Boiler connection kit						Details			
DHW kit									
Cooling kit									
Control settings									
Configuration type									
Essential settings									